

EXPORT - UNPRICED

**LIST OF
SPARE PARTS
FOR
ARIEL
THE MODERN
MOTOR CYCLE**



**SINGLE CYLINDER
MODELS**

ARIEL MOTORS LTD.

SELLY OAK BIRMINGHAM 29

Telephone: SELLY OAK 1381 Telegrams: ARIEL, SELLY OAK
Cables: ARIEL, SELLY OAK (ENGLAND)

Price . . . Two Shillings and Sixpence

ARIEL

The Modern Motor Cycle



**Owners of Ariel Motor Cycles
are strongly advised to buy
Genuine Ariel Spare Parts only**

PLEASE NOTE

Part Numbers quoted in this book are those prevailing at the time of publication, but we reserve the right to revise prices and introduce any modification deemed necessary at any time without prior notice.

Spare Parts for Ariel Motor Cycles should be obtained through our appointed dealers and Spares Stockists, who carry comprehensive stocks or can obtain at short notice parts not readily available.

1956 SINGLE CYLINDER MODELS

- VH. 500 c.c. Red Hunter
- NH. 350 c.c. Red Hunter
- VB. 600 c.c. Side Valve
- HS. 500 c.c. Scrambles Red Hunter
- HT. 500 c.c. Trials Red Hunter

Published March 1956

Ref. CWW/TCP

ARIEL MOTORS LTD.
SELLY OAK BIRMINGHAM 29
Telephone: SELLY OAK 1381 Telegrams: ARIEL, SELLY OAK
Cables: ARIEL, SELLY OAK (ENGLAND)

SINGLE CYLINDER MODELS

I N D E X

	Page		Page
Air Cleaner	41	Lighting Set Fittings	37
Brake Pedal (Rear) with Rod, Cable and Fittings	32-33	Lucas Electrical Equipment	41
Carburettor Components	40-41	Magneto Fixing	14-15
Chain Covers	34-35	Mudguard (Rear)	34
Clutch Components	19-20	Nuts, Washers, etc.	42
Control Cables	38-39	Oil Pump Parts	14
Crankcase and Fittings	11-12	Oil Tank and Fittings	36
Cylinder and Fittings	8-9	Petrol Tank and Fittings	31-32
Dualseat	38	Pillion Footrests	33
Engine Plates	14-15	Piston and Fittings	12
Exhaust System	37	Prop Stand	15
Exhaust Valve Lifter	9	Rocker Box and Fittings	10
Flywheel Assembly	10-11	Saddle	38
Footrests	32-33	Shock Absorber, Engine Shaft	11
Frame (Pivoted Rear Suspension)	29-31	Speedometer Fittings	32
Front Fork and Fittings	25-28	Sprockets (Engine)	11
Front Mudguard	28-29	Stand (Centre)	15
Gasket Sets	9	Steering Head and Fittings	28
Gearbox Components	15-20	Timing Gear	13
Gear Cover and Fittings	13-14	Tool Kit	39-40
Handlebar Controls	38	Valves and Fittings	9-10
Handlebars	38	Wheel and Hub (Front)	23-25
		Wheel and Hub (Rear), P.R.F. Frame	20-23

NOTE. — The letters R/S and L/S mean the right-hand side and left-hand side respectively when the rider is on the saddle.

Standard nuts, washers, etc., are listed on page 42 and are not shown separately each time they occur with individual components. This avoids needless repetition

ARIEL MOTORS LIMITED
PROPRIETARY EQUIPMENT AND ACCESSORIES

Although every effort is made to obtain the most suitable and highest quality fittings of a proprietary nature for incorporating into our Motor Cycles, our guarantee does not cover such parts.

In the event of trouble being experienced with proprietary fittings, the part or parts should be returned to and claims made direct on the actual manufacturers, who will deal with them on the terms of their respective guarantees. Date of purchase and mileage covered should always be carefully stated when submitting a claim.

CARBURETTORS

AMAL LTD.,
Holdford Road, Witton, Birmingham 6

CHAINS

THE RENOLD & COVENTRY CHAIN CO. LTD.,
Didsbury, Manchester

ELECTRICAL EQUIPMENT

Messrs. JOSEPH LUCAS LTD. (Service Dept.),
Great King Street, Birmingham 19 and Great Hampton Street, Birmingham 18

HORNS

Messrs. JOSEPH LUCAS LTD. (Service Dept.),
Great King Street, Birmingham 19 and Great Hampton Street, Birmingham 18

CLEAR HOOTERS LTD.,
33 Hampton Street, Birmingham 19

SADDLES

WRIGHT SADDLE CO. LTD.,
160 Bristol Street, Birmingham 5

SPEEDOMETERS

Messrs. S. SMITH (MA) LTD.,
Cricklewood, London

TYRES

THE DUNLOP RUBBER CO. LTD.,
Fort Dunlop, Erdington, Birmingham 24

SPARKING PLUGS

CHAMPION SPARKING PLUG CO. LTD.,
Feltham, Middlesex

LODGE PLUGS LTD.,
Rugby

GEARBOXES

Messrs. BURMAN & SONS LTD.,
Wychall Lane, Kings Norton, Birmingham 30

PLEASE NOTE

Ariel Stockists are appointed to cover all areas throughout Great Britain and are normally in a position to supply spares from stock.

A list of our Stockists is given in the back of this book, and if you will place your order with the Stockist of your choice, he will, if unable to supply your requirements from stock, accept your order for delivery with the least possible delay.

1956 ENGINE AND FRAME PREFIX LETTERS

<i>Model</i>					<i>Engine</i>	<i>Frame</i>
NH.	350 c.c.	MA	PR
VH.	500 c.c.	MB	PR
VB.	600 c.c.	MC	PR
HS.	500 c.c.	MH	PRS
HT.	500 c.c.	MJ	RT

Order by
SPARES
No.

DESCRIPTION OF PART

No.
per Set

CYLINDERS AND FITTINGS

3-52	Cylinder head only, S.V. (VB)	1	..
6-52	Cylinder barrel, fitted valve guides, 597 c.c. S.V. (VB)	1	..
6C-52	Cylinder barrel c/w valve guides, valves and springs, etc., less exhaust lifter and valve cover, 597 c.c. S.V.	1	..
20-54	Cylinder barrel only, 500 c.c. (VH)	1	..
23-56C	Cylinder barrel c/w liner (HS and HT)	1	..
26-56	Cylinder barrel only, 350 c.c. (NH)	1	..
32-53	Liner for cylinder barrel (HS Mk. I and Mk. III and HT)	1	..
35-56	Cylinder head and valve guides, 500 c.c. (VH and HT)	1	..
46-56	Cylinder head and valve guides, 500 c.c. (HS)	1	..
51-56	Cylinder head and valve guides, 350 c.c. (NH)	1	..
73-52	Cylinder head gasket, S.V. (VB)	1	..
95-54	Carburetter joint washer (HS Mk. I)	2	..
95-54	Carburetter flange joint washer (HS Mk. III, VH and HT)	1	..
95-54	Carburetter flange joint washer (NH and VB)	2	..
0199	Carburetter fixing stud (VH and HS Mk. III)	2	..
S1-3	Nut for carburetter fixing stud (VH, NH, VB and HT)	2	..
0183	Carburetter fixing stud (VB)	2	..
100-54	Carburetter flange packing piece (HS Mk. I)	1	..
104-55	Carburetter flange packing piece (HT)	1	..
105-35	Valve spring cover, S.V. (VB)	1	..
108-55	Adaptor for carburetter, S.V. (VB)	1	..
0216	Bolt for carburetter adaptor, S.V. (VB)	2	..
109-30	Joint washer for valve spring cover, S.V. (VB)	1	..
116-38	Fibre washer for valve cover stud, S.V. (VB)	1	..
117-34	Nut for valve spring cover stud, S.V. (VB)	1	..
125-31	Cylinder base washer, S.V. (VB)	1	..
128-52	Cylinder base washer (VH, NH, HS and HT)	1	..
139-53	Rubber connection for oil feed pipe	1	..
140A-52	Oil feed pipe assembly (top half) for rocker connection (NH, VH, HS and HT)	1	..
141B-52	Oil feed pipe (bottom half) (NH, VH, HS and HT)	1	..
150-52	Timing plug in cylinder head (VB)	1	..
162-52	$\frac{1}{8}$ " B.S.F. nut securing cylinder head (VB)	9	..
169-54	Nut for cylinder head stud (VH, HS and HT)	5	..
174-56	Washer for cylinder head stud (VH, HS and HT)	5	..
190-36	Breather pipe and swivel connection, S.V. (VB)	1	..
195-36	Union for breather pipe, S.V.	1	..
197-36	Fibre washer for 195-36 union, S.V. (VB)	2	..
225-33	Tappet guide, S.V. (VB)	2	..
1890A-40	Rubber oil retaining ring in cylinder head (NH, VH and HS)	2	..
S2-2	Locknut for 0120 stud	1	..
S19-3	Washer for cylinder head stud, S.V.	9	..
0120	Valve cover stud ($\frac{1}{4}$ " x $2\frac{1}{4}$ ") (VB)	1	..
0204	Cylinder head stud, S.V. (VB)	9	..
0215	Carburetter fixing stud (HT)	2	..
0218	Carburetter fixing stud (HS Mk. I)	2	..

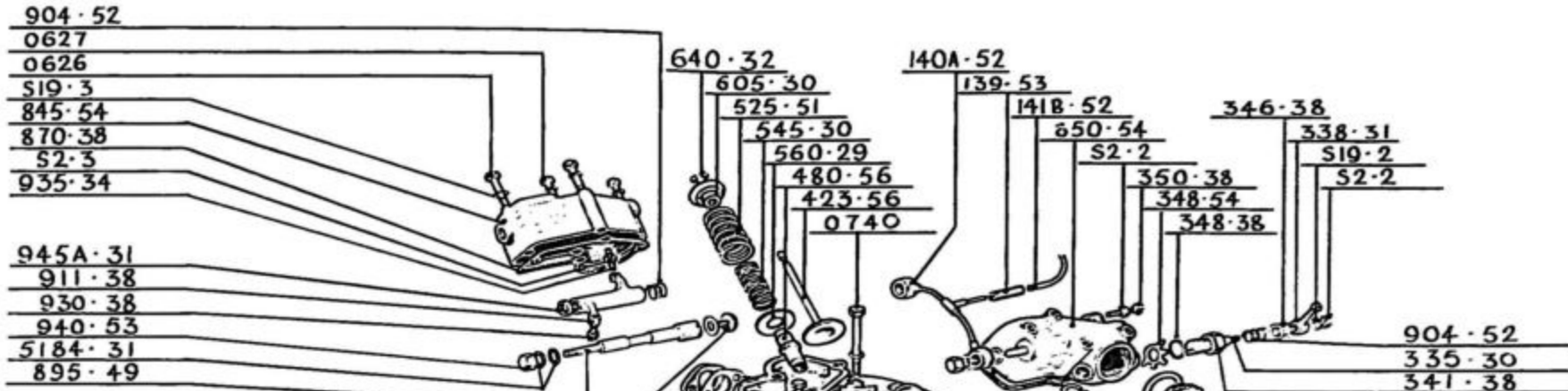

ARIEL

350cc O.H.V. MODEL N.H.

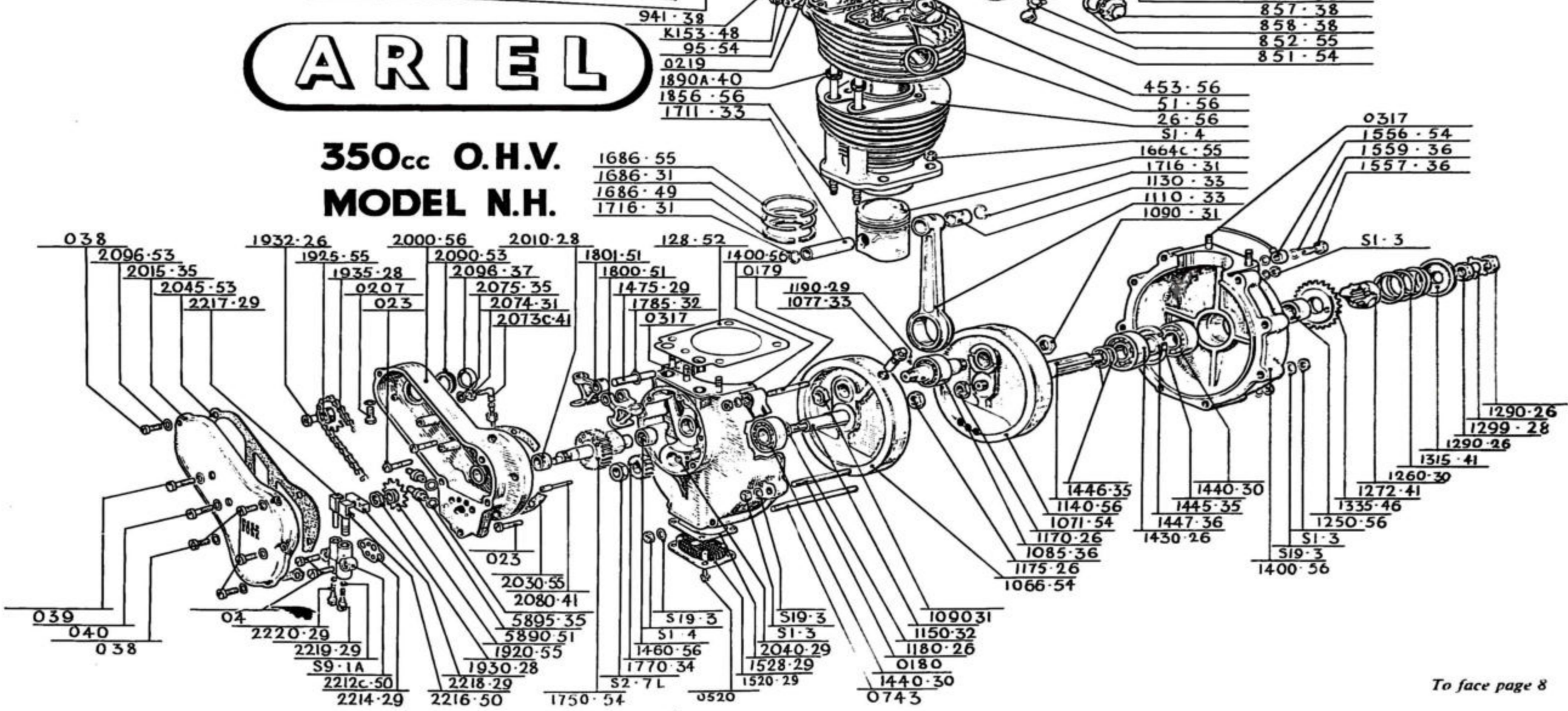

To face page 8

Order by SPARES No.	DESCRIPTION OF PART	No. per Set
0219	Carburettor fixing stud (NH)	2
K153-48	Carburettor flange distance washer (NH)	1
0305	Cylinder head stud (VH, HS and HT)	5
0740	Cylinder head bolt (NH)	4
S19-4	Washer for cylinder head bolt (NH)	4

GASKET SETS

GS110-54	Carton, engine joint washers and gaskets, S.V. (VB)	per set
GS111-56	Carton, engine joint washers and gaskets, 350 c.c. O.H.V. (NH)	per set
GS113-54	Carton, engine joint washers and gaskets, 500 c.c. O.H.V. (VH)	per set

EXHAUST VALVE LIFTER

330-38	Exhaust lifter complete, O.H.V.	1
330-39	Exhaust lifter complete, S.V. (VB)	1
335-30	Exhaust lifter spindle	1
338-30	Exhaust lifter lever, S.V. (VB)	1
338-31	Exhaust lifter lever, O.H.V.	1
341-38	Exhaust lifter bush	1
344A-38	Exhaust lifter spring washer	1
346-38	Exhaust lifter shim (pen steel)	2
347-29	Volute spring (exhaust lifter cable)	1
348-38	Washer for lifter bush	1
348-54	Exhaust lifter tab washer (HT, NH, VH and HS)	1
350-29	Exhaust cable stop lug, S.V.	1
350-38	Exhaust cable stop lug, O.H.V.	1
361-34	Exhaust cable adjuster locknut, S.V.	1
S25-2	Exhaust cable adjuster, S.V. (VB)	1
S2-2	Locknut for exhaust lifter lever	1
S2-2	Exhaust lifter cable stop lug nut	1
S19-2	Plain washer for exhaust lifter lever	1

VALVES AND FITTINGS

400-52	Valve, inlet, S.V. (VB)	1
415-35	Valve, inlet (VH, HS and HT)	1
423-56	Valve, inlet (NH)	1
430-52	Valve, exhaust, S.V. (VB)	1
441-55	Valve, exhaust (VH, HS and HT)	1
453-56	Valve, exhaust (NH)	1
460-29	Valve guide (VB)	2
470-50	Valve guide, inlet (VH, HS and HT)	1
480-56	Valve guide, inlet (NH)	1
491-55	Valve guide, exhaust (VH, HS and HT)	1
494-56	Valve guide, exhaust (NH)	1
515-31	Valve spring, outer (VB, VH and HT)	2
515-54	Valve spring, outer (HS)	2
525-51	Valve spring, outer (NH)	2
545-30	Valve spring, inner (VH, HS, NH and HT)	2
570-30	Collar, spring retaining (base) (HS)	2
560-29	Collar for spring (pressing) (VB, VH, NH and HT)	2

Order by
SPARES
No.

DESCRIPTION OF PART

No.
per Set

580-34	Washer (Hallite) under top collar (exhaust valve) (VB)	1	..
590-26	Collar for spring (taper hole) (VB)	2	..
605-30	Collar for spring (taper hole), O.H.V.	2	..
620-26	*Split cone (two halves), S.V. (VB)	2	..
640-32	*Split cone (two halves) (NH)	2	..
640-30	*Split cone (two halves) (VH, HS and HT)	2	..
650-34	Valve stem end cap (VH, HS and HT)	2	..

*Note.—One split cone consists of two halves. Thus one pair of split cones consists of two complete cones, equal to four halves or pieces.

ROCKER BOX AND FITTINGS

845-54	Rocker box, inlet	1	..
850-54	Rocker box, exhaust	1	..
851-54	Inspection plug for tappet adjustment	2	..
852-55	Washer for inspection plug	2	..
857-38	Screw cap for rocker box	2	..
858-38	Screw cap washer	2	..
870-38	Rocker box joint washer	2	..
895-49	Rocker spindle	2	..
904-52	Rocker spring	2	..
911-38	Rocker lever and fixed end pin, inlet	1	..
921-38	Rocker lever and fixed end pin, exhaust	1	..
930-38	Rocker lever end pin only	2	..
935-34	Rocker lever adjusting screw	2	..
S2-3	Rocker lever adjusting screw locknut	2	..
940-53	Dome nut for rocker spindle	2	..
5184-31	Fibre washer (domed nut—rocker spindle) (inter. 148-38)	4	..
941-38	Oil seal screw for rocker spindle	2	..
942-38	Oil seal screw washer	2	..
945A-31	Distance collar for rocker spindle	2	..
0626	Rocker box bolt (long)	2	..
0627	Rocker box bolt (short)	6	..
S19-3	Washer for rocker box bolt	8	..

FLYWHEEL ASSEMBLY

1051-56	Flywheel, drive side (VH)	1	..
1053-56	Flywheel, drive side (HS and HT)	1	..
1055-56	Flywheel, gear side (VH)	1	..
1054-56	Flywheel, gear side (HS and HT)	1	..
1056-36	Flywheel, gear side (VB)	1	..
1060-36	Flywheel, drive side (VB)	1	..
1066-54	Flywheel, gear side (NH)	1	..
1071-54	Flywheel, drive side (NH)	1	..
1077-33	Oil purifier cupped plug (NH, VH, VB, HS and HT)	1	..
1080-29	Crankpin and roller bearing complete (VB)	1	..
1080-37	Crankpin and roller bearing complete (VH, HS and HT)	1	..
1085-36	Crankpin and roller bearing complete (NH)	1	..
1090-31	Crankpin nut ($\frac{3}{8}$ " x 20) (NH)	2	..
1090-56	Crankpin nut (VB)	2	..
1090-35	Crankpin nut ($\frac{3}{8}$ " x 20) (VH, HS and HT)	2	..
1100-35	Connecting rod and S.c. bush (VB)	1	..

ARIEL 497^{cc} O.H.V. MODEL "VH"

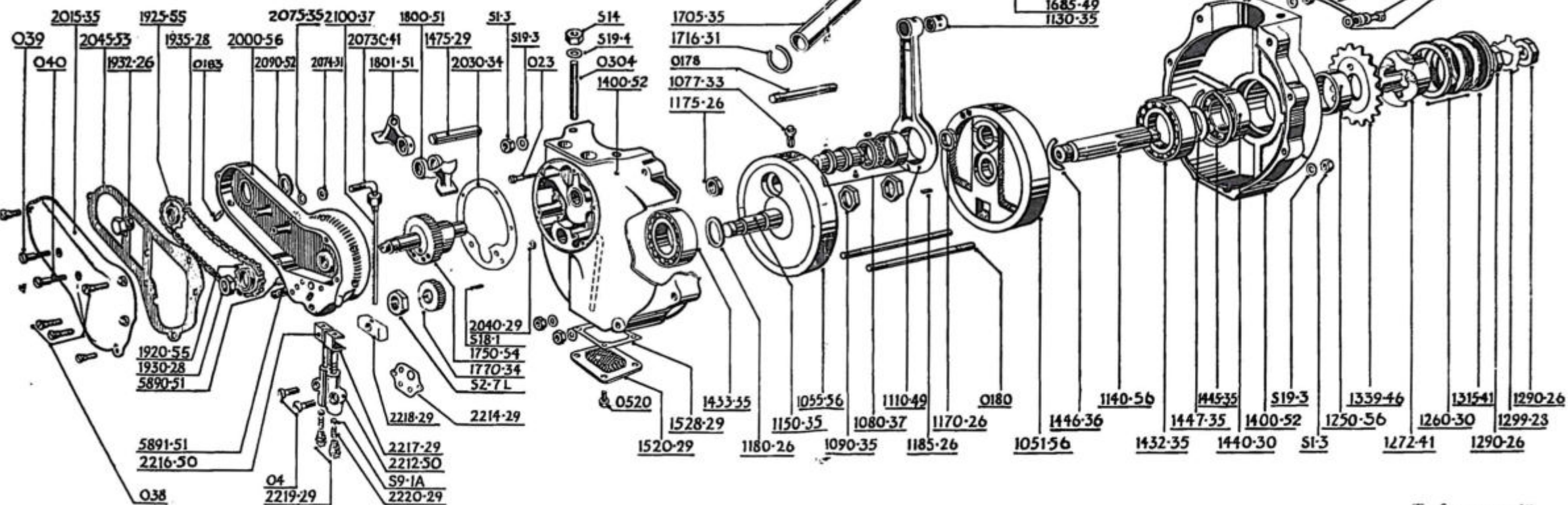
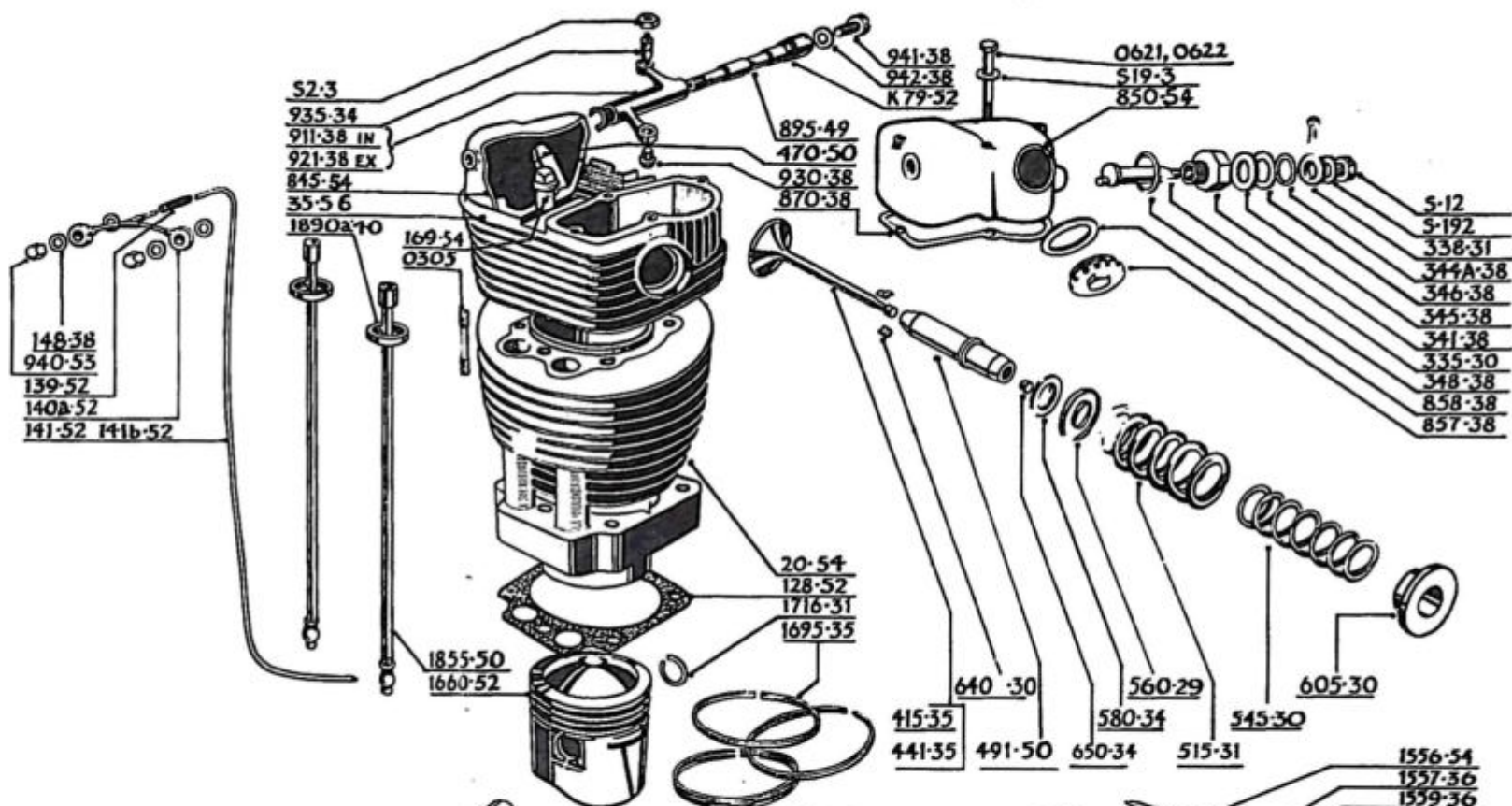

To face page 10

Order by SPARES No.	DESCRIPTION OF PART	No. per Set
1110-33	Connecting rod and S.E. bush (NH) ..	1 ..
1110-49	Connecting rod and S.E. bush (VH, HS and HT) ..	1 ..
1130-33	Small end bush (NH) ..	1 ..
1130-35	Small end bush (VH, VB, HS and HT) ..	1 ..
1140-56	Drive side spindle (NH, VH, VB, HS and HT) ..	1 ..
1150-32	Gear side spindle and peg (NH and VB) ..	1 ..
1150-35	Gear side spindle and peg (VH) ..	1 ..
1150-36	Spindle and peg, gear side (HS and HT) ..	1 ..
1170-26	Drive side spindle nut ($\frac{1}{8}$ " \times 20), R/S ..	1 ..
1175-26	Gear side spindle nut ($\frac{1}{8}$ " \times 20), L/S ..	1 ..
1180-26	Distance washer, hardened (supplied in 12, 13, 14, 15, 16, 17 and 27 gauge) ..	as reqd. ..
1180-56	Washer, roller bearing—flywheels (VH, HS and HT) ..	2 ..
1185-26	No. 9 Woodruff key for drive spindle ..	1 ..
1190-29	Peg for gear spindle ..	1 ..
1190-29	Peg for big end bearing ..	1 ..

Note.—All flywheels are balanced before despatch.

SHOCK ABSORBER AND ENGINE SPROCKETS

1249-49	Rubber oil seal c/w spring (HS and HT) ..	1 ..
1250-56	Sprocket distance piece ..	1 ..
1260-30	Shock absorber spring ..	1 ..
1272-41	Sliding member ..	1 ..
1290-26	Sprocket securing nut ($\frac{1}{8}$ " \times 20T) ..	2 ..
1297-49	Washer (pen steel) for oil seal (HT) ..	1 ..
1297-56	Washer for 1249-49 oil seal (HS and HT) ..	1 ..
1299-28	Lockwasher ..	1 ..
1315-41	Spring plate ..	1 ..
1334-46	Engine sprocket, 18 teeth ..	1 ..
1335-46	Engine sprocket, 19 teeth ..	1 ..
1337-46	Engine sprocket, 21 teeth ..	1 ..
1338-41	Engine sprocket, 22 teeth ..	1 ..
1339-46	Engine sprocket, 23 teeth ..	1 ..

CRANKCASE AND FITTINGS

1400-56	Crankcase only, less all fittings (NH, HT, VH and VB) ..	1 ..
1401-56	Crankcase only, less all fittings (HS) ..	1 ..
1432-35	Roller bearing (non-lipped), drive side (VH, HS, HT and VB) ..	1 ..
1433-35	Roller bearing (lipped), gear side (VH, HS, HT and VB) ..	1 ..
1430-26	Ball bearing, drive side (NH) ..	1 ..
1440-30	Ball bearing, drive side and gear side (VB and NH) ..	2 ..
1440-30	Ball bearing, drive side (VH, HS and HT) ..	1 ..
1445-35	Circlip for drive side ball bearing (NH, HT, VH, VB and HS) ..	1 ..
1446-36	Bearing distance collar (narrow) (VH, HS and HT) ..	1 ..
1446-35	Bearing distance collar (narrow) next to flywheel (NH and VB) ..	1 ..

Order by SPARES No.	DESCRIPTION OF PART	No. per Set
1447-35	Bearing distance collar (.274" wide) between bearings (HS, VH, VB and HT)	1 ..
1447-36	Bearing distance collar (.285" wide) between bearings (NH)	1 ..
1460-56	Camwheel bush for crankcase	1 ..
1460-55	Camwheel bush for crankcase (HS)	1 ..
1475-29	Cam lever pin	1 ..
1520-29	Oil sump base with gauze	1 ..
1528-29	Oil sump base joint washer	1 ..
1533-29	Oil return pipe (from sump)	1 ..
1537-32	Oil joint pipe (at crankcase gear cover joint)	1 ..
1546-56	Breather pipe (rubber), 18" long (HS and HT)	1 ..
1556-54	Breather pipe and swivel piece, O.H.V.	1 ..
1557-36	Breather pipe union (inter. 195-36)	1 ..
1559-36	Fibre washer (inter. 197-36)	2 ..
1561-54	Breather pipe and swivel piece (VB)	1 ..
1545-56	Dowel (crankcase to gear cover)	2 ..
0317	Cylinder base stud (VB)	4 ..
0317	Cylinder base stud (NH)	5 ..
0315	Cylinder base stud (HT and HS)	5 ..
0304	Cylinder base stud ($\frac{3}{8}$ " x $1\frac{7}{8}$ ") (VH)	5 ..
0520	Oil sump base set screw ($\frac{1}{4}$ " x $\frac{3}{8}$ ")	4 ..
S19-4	Plain washer for cylinder base stud (NH, VH and HT)	5 ..
S19-4	Plain washer for cylinder base stud (VB)	4 ..
S1-4	Nut for cylinder base stud	5 ..
S1-4	Nut for cylinder base stud (VB)	4 ..
128-55	Plain washer for cylinder base stud (HS)	5 ..
135-55	Nut for cylinder base stud (HS)	5 ..

PISTON AND FITTINGS

1650C-55	Piston complete (comp. ratio 6-1), S.V. (VB)	1 ..
1660C-55	Piston complete (comp. ratio 6.8-1), 500 c.c. (VH)	1 ..
1661C-55	Piston complete (comp. ratio 9-1), 500 c.c. (HS)	1 ..
1664C-55	Piston complete (comp. ratio 7.5-1), 350 c.c. (NH)	1 ..
1670C-55	Piston complete (comp. ratio 5.6-1) (HT)	1 ..
1686-55	Piston ring (chrome), top, 350 c.c. (NH)	1 ..
1686-31	Piston ring (compression), 350 c.c. (NH)	1 ..
1686-49	Piston ring (oil control), 350 c.c. (NH)	1 ..
1695-55	Piston ring (chrome), top (VH and HT)	1 ..
1695-35	Piston ring (compression) (VH and HT)	1 ..
1685-49	Piston ring (oil control) (VH, HS and HT)	1 ..
1694-55	Piston ring (chrome), top, S.V. (VB)	1 ..
1695-31	Piston ring (compression), S.V. (VB)	1 ..
1695-49	Piston ring (oil control), S.V. (VB)	1 ..
1696-55	Piston ring (Vacrom), top, 500 c.c. (HS)	1 ..
1691-55	Piston ring (compression), 500 c.c. (HS)	1 ..
1698-55	Piston ring (oil control), 500 c.c. (HS)	1 ..
1700-31	Gudgeon pin, 600 c.c. (VB)	1 ..
1705-35	Gudgeon pin, 500 c.c. (VH, HT and HS)	1 ..
1711-33	Gudgeon pin, 350 c.c. (NH)	1 ..
1716-31	Circlip (NH, VH, HT, HS and VB)	2 ..

Note.—Piston complete comprises piston, rings, gudgeon pin and circlips.

ARIEL 600^{cc} S.V. MODEL "V.B."

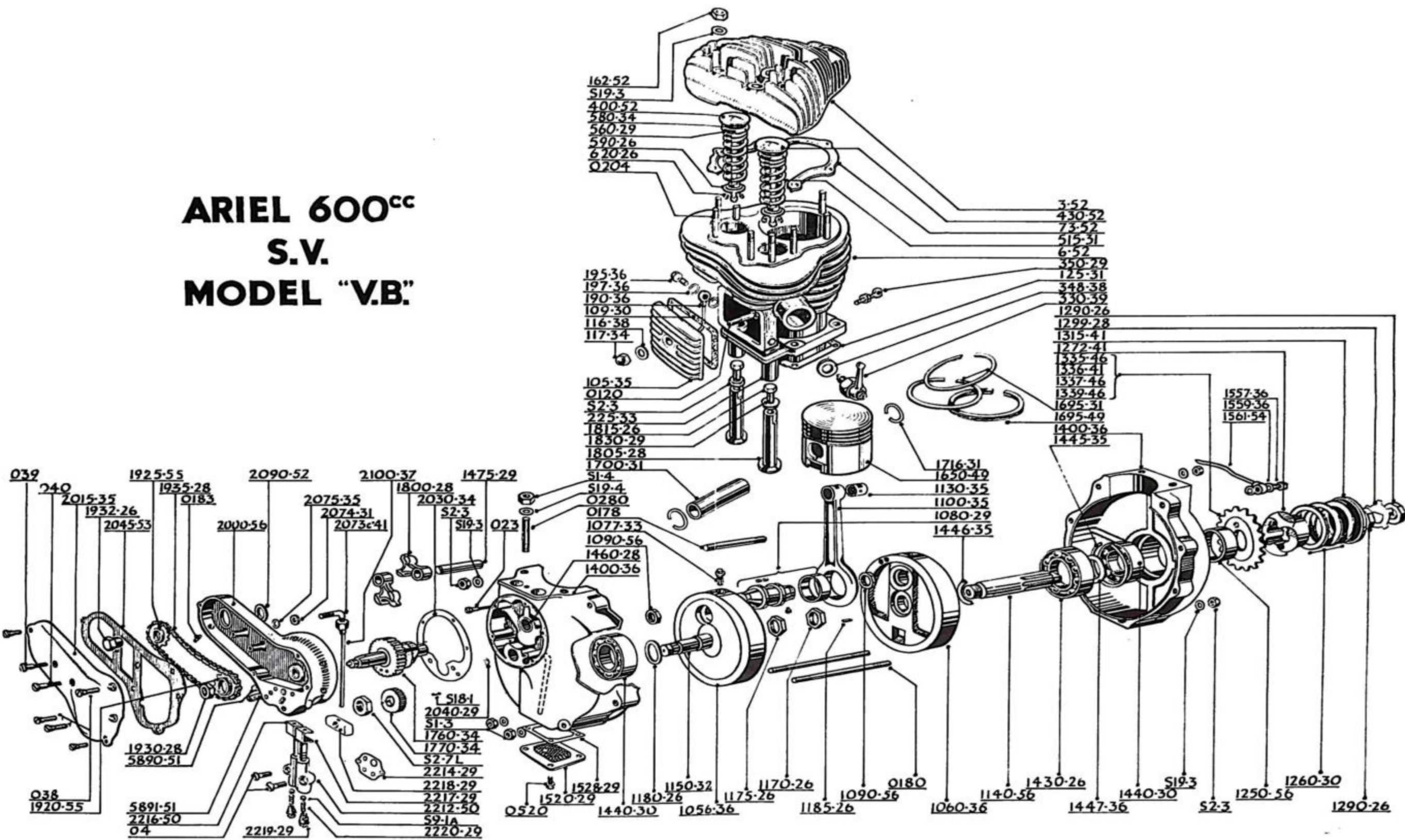

To face page 12

Order by
SPARES
No.

DESCRIPTION OF PART

No.
per Set

TIMING GEAR

1750-54	Camwheel assembly (NH, VH and HT) ..	1	..
1750-55	Camwheel assembly (HS Mk. III) ..	1	..
1751-56	Camwheel assembly (HS Mk. I) ..	1	..
1760-34	Camwheel assembly, S.V. (VB) ..	1	..
1770-34	Timing pinion ..	1	..
1774-28	No. 3 Woodruff key ..	1	..
S2-7L	Nut, securing timing pinion ..	1	..
1785-29	Shim for cam spindle (20-25 gauge) ..	1	..
1785-32	Shim for cam lever spindle ..	1	..
1800-28	Cam lever, S.V. (VB) ..	2	..
1800-51	Cam lever, exhaust (NH, VH, HT and HS Mk. III) ..	1	..
1800-54	Cam lever, exhaust (HS Mk. I only) ..	1	..
1801-51	Cam lever, inlet (NH, VH and HT) ..	1	..
1801-54	Cam lever, inlet (HS) ..	1	..
1805-28	Tappet only, S.V. (VB) ..	2	..
1815-26	Tappet adjusting screw, S.V. (VB) ..	2	..
1830-29	Tappet adjusting screw locknut (exhaust), S.V. (VB) ..	1	..
S2-3	Inlet tappet locknut, S.V. (VB) ..	1	..
1855-50	Tappet tube with ends (VH, HS and HT) ..	2	..
1856-56	Tappet tube with ends (NH) ..	2	..
1920-55	Timing sprocket for cam spindle (NH, VH, VB, HS and HT) ..	1	..
1925-55	Timing sprocket for magdyno spindle (NH, VH, VB, HS and HT) ..	1	..
1930-28	Nut, securing camshaft sprocket ..	1	..
1932-26	Nut, securing magdyno sprocket ..	1	..
1935-28	Magdyno chain ($\frac{1}{2}$ " \times $\frac{1}{8}$ " \times 35 pitches) ..	1	..

GEAR COVER AND FITTINGS

2000-56	Gear cover with bush, oil delivery pipe, pressure valve and 2073C-41 elbow union (NH, VB, VH and HT) ..	1	..
2005-56	Gear cover with bush, oil delivery pipe, pressure valve and 2073C-41 elbow union (HS Mk. I and Mk. III) ..	1	..
2010-28	Camshaft bush (NH, VH, VB and HT) ..	1	..
2010-55	Camshaft bush (HS) ..	1	..
2015-35	Magneto chain cover (state model if engraved cover required) ..	1	..
2030-55	Joint washer between crankcase and gear cover (NH, VH, VB and HT) ..	1	..
2030-56	Joint washer between crankcase and gear cover (HS Mk. I and Mk. III) ..	1	..
2040-29	Extra .005" washer for oil return pipe joint (NH, VH, VB, HS and HT) ..	1	..
2045-53	Joint washer, gear cover to chain cover (NH, VH, VB, HS and HT) ..	1	..
2073C-41	Elbow union, 90°, with ball and pin for breather pipe ..	1	..
5890-51	Oil pipe union (gear cover to oil tank) ..	2	..
5895-35	Fibre washer for 5890-51 ..	2	..
2074-31	Elbow union locknut ..	1	..
2075-35	Elbow union locknut washer ..	1	..
2080-41	Big end feed pipe (NH, VH, VB, HS and HT) ..	1	..
2080-56	Oil drain pipe (HS Mk. I and Mk. III) ..	1	..

Order by SPARES No.	DESCRIPTION OF PART	No. per Set
2090-53	Rubber washer (armature shaft), (NH, VH, VB, HT and HS Mk. III)	1 ..
2091-38	Composition oil excluding washer (armature shaft)	1 ..
2096-37	Steel retaining washer	1 ..
2096-53	Fibre washer for screws	12 ..
2097-55	Oil retaining washer (magneto) (HS and HT)	1 ..
2098-55	Oil seal retaining ring (magneto) (HT and HS)	1 ..
2100-41	Breather pipe with nipple and nut (behind case)	1 ..
023	Cheese-head screw for gear cover ($\frac{1}{4}$ " \times $1\frac{1}{4}$ " \times 20 T.P.I.)	5 ..
038	Cheese-head screw for chain cover ($\frac{1}{4}$ " \times $\frac{3}{4}$ " \times 20 T.P.I.)	5 ..
039	Cheese-head screw for chain cover ($\frac{1}{4}$ " \times $1\frac{1}{8}$ " \times 20 T.P.I.)	1 ..
040	Cheese-head screw for chain cover ($\frac{1}{4}$ " \times $1\frac{3}{8}$ " \times 20 T.P.I.)	1 ..
0207	Bolt for magneto platform (Lucas magneto only)	1 ..
S9-2	Ball for valve in elbow union	1 ..
S21-2	Oil pipe nut	1 ..

OIL PUMP

2212C-50	Oil pump c/w plungers, block, valves, plugs, etc.	1 ..
2212-50	Oil pump body only	1 ..
2214-29	Joint washer (paper)	1 ..
2216-50	Plunger, delivery	1 ..
2217-29	Plunger, return	1 ..
2218-29	Duralumin block	1 ..
2219-29	Plug for plunger ball valve	2 ..
2220-29	Spring for plunger valve	2 ..
S9-1A	Ball for plunger valve ($\frac{7}{32}$ " dia.)	2 ..
04	Cheese-head screw for oil pump body ($\frac{1}{4}$ " \times $\frac{7}{8}$ " \times 20 T.P.I.)	2 ..

ENGINE PLATES, TIE BOLTS AND MAGNETO PLATFORM

2301-54	Front engine plate (NH, VH, VB and HS)	2 ..
2302-56	Front engine plate (HT)	2 ..
2304-54	Gearbox plate assembly, R/S (VH, NH, HS and VB)	1 ..
2305-56	Gearbox plate assembly, R/S (HT)	1 ..
2306-56	Gearbox plate assembly, L/S (HT)	1 ..
2311-54	Gearbox plate, L/S (NH, VH, HS and VB)	1 ..
2316-54	Front cover for engine plates (NH, VH, HS and VB)	1 ..
2330-55	Gearbox adjuster (HT)	1 ..
2330-54	Gearbox adjuster (NH, VH, VB and HS)	1 ..
2336-52	Gearbox adjuster nut (HT)	1 ..
2336-35	Nut for adjuster (except HT)	1 ..
0178	Tie bolt ($\frac{1}{8}$ " \times $2\frac{1}{8}$ " \times 26 T.P.I.)	1 ..
0179	Tie bolt ($\frac{1}{8}$ " \times $3\frac{1}{4}$ " \times 26 T.P.I.)	1 ..
0180	Tie bolt ($\frac{1}{8}$ " \times $4\frac{3}{8}$ " \times 26 T.P.I.)	2 ..
0276	Tie bolt ($\frac{1}{8}$ " \times $3\frac{3}{8}$ " \times 26 T.P.I.)	3 ..

Order by SPARES No.	DESCRIPTION OF PART	No. per Set
0917	Gearbox clamp bolt ($\frac{1}{2}$ " \times $4\frac{1}{2}$ " \times 20 T.P.I.) ..	2 ..
0917	Stud for gearbox fixing (HT) ..	3 ..
0513	Set bolt for magneto platform, L/S ($\frac{1}{4}$ " \times $\frac{1}{2}$ " \times 26 T.P.I.) ..	1 ..
0731	Set bolt for magneto ..	3 ..
0963	Tie bolt ($6\frac{3}{4}$ " \times $\frac{7}{16}$ " \times 26 T.P.I.) ..	1 ..
0743	Tie bolt ($7\frac{1}{2}$ " \times $\frac{3}{8}$ " \times 26 T.P.I.) ..	1 ..
2382-55	Gearbox pivot stud assembly ..	1 ..
2382-56	Gearbox pivot bolt (HT) ..	1 ..
2380A-54	Distance tube (upper front) ..	2 ..
2380B-54	Distance piece (lower front) ..	2 ..
2380D-54	Distance piece (upper front) ..	2 ..
2380-56	Distance piece for pivot stud assembly ..	2 ..
2384-56	Distance piece for gearbox stud (HT) ..	1 ..
2400-54	Undershield for crankcase (Dural) (HS Mk. I) ..	1 ..
2400-56	Undershield for crankcase (HT) ..	1 ..
2404-56	Cover for rear engine plates (Dural) (HS Mk. I) ..	1 ..
2323-54	Stud, securing rear cover to primary cover (HS Mk. I) ..	2 ..
5187-50	Domed nut for stud 2323-54 ..	2 ..
2362-56	Stud for side stays (HT) ..	1 ..

PROP STAND

2450-53C	Prop stand complete (VH, NH and VB) ..	1 ..
2450-53	Prop stand leg (VH, NH and VB) ..	1 ..
2465-53	Prop stand pivot pin (VH, NH and VB) ..	1 ..
2461-52	Prop stand spring (VH, NH and VB) ..	1 ..
	$\frac{1}{16}$ " B.S.F. nut ..	1 ..

CENTRE STAND

2500-54	Centre stand only (NH, VH, VB and HS Mk. III) ..	1 ..
2505-54	Rubber stop for centre stand ..	1 ..
2502-54	Pivot pin for centre stand ..	2 ..
S19-6	Washer ..	4 ..
2503-54	Circlip for pivot pin ..	4 ..
2504-56	Spring for centre stand ..	2 ..

GEARBOX PARTS

Makers of gearbox: Messrs. BURMAN & SONS LTD.,
Wychall Lane, Kings Norton, Birmingham 30.

GB39 Gearbox fitted two-plate clutch assembly, Model NH, 350 c.c.
GB40 Gearbox fitted three-plate clutch assembly, Models VH and VB, 500 c.c. and 600 c.c.
GB45 Gearbox fitted three-plate clutch assembly, Model HS, 500 c.c.
GB47 Gearbox fitted two-plate clutch assembly, Model HT, 500 c.c.

3600-52	Gearbox shell only ..	1 ..
3600-56	Gearbox shell only (GB47 only) ..	1 ..
3602-52	Gearbox joint washer ..	1 ..
3602-56	Gearbox joint washer (GB47 only) ..	1 ..
3610-52	Kick-starter case ..	1 ..
3610-56	Kick-starter case (GB47 only) ..	1 ..
3611-52	Kick-starter case joint washer ..	1 ..

EXPLODED VIEW OF GEARBOX (TYPE GB)

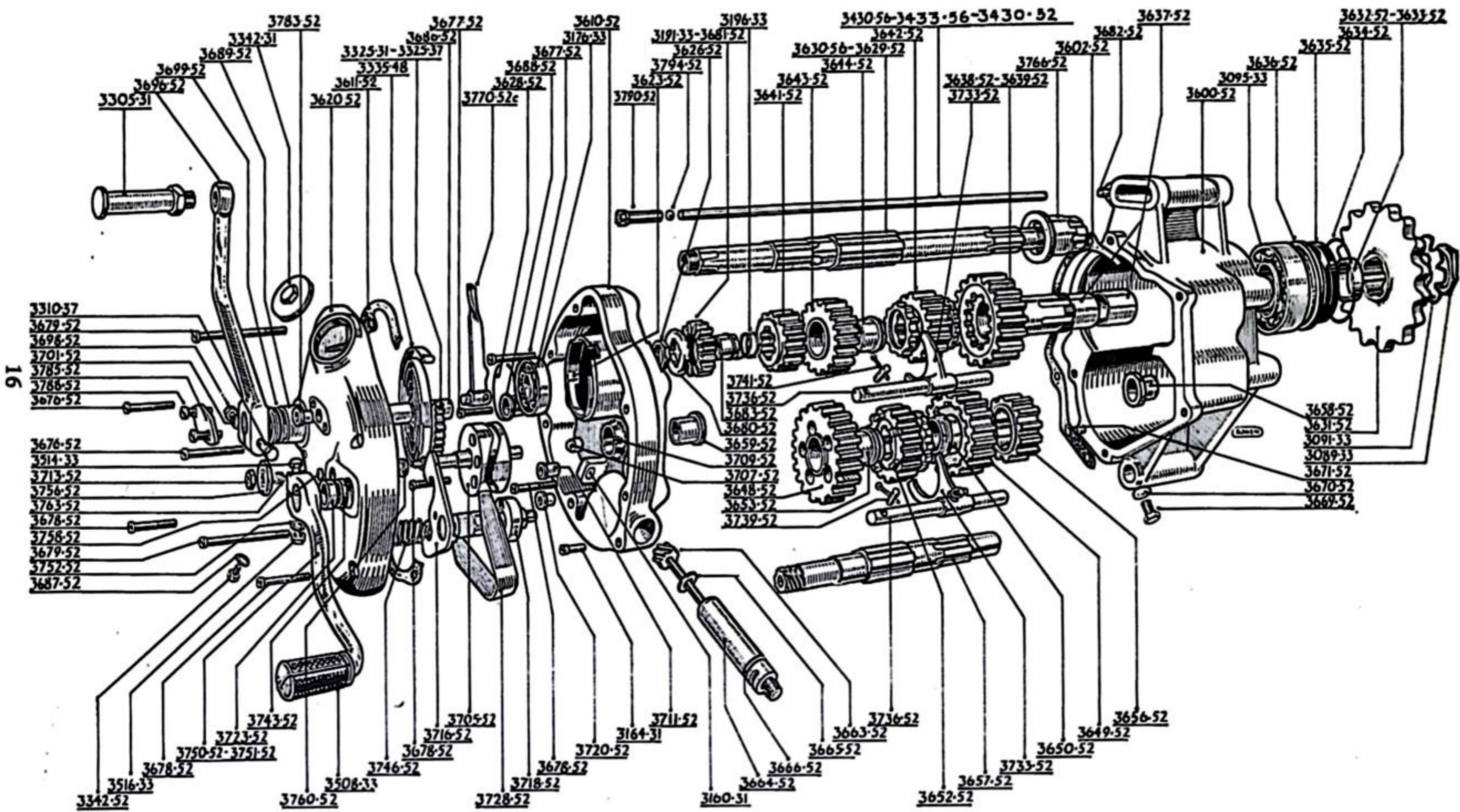

Order by SPARES No.	DESCRIPTION OF PART	No. per Set
3611-56	Kick-starter case joint washer (GB47 only)	1 ..
3620-52	Kick-starter case cover	1 ..
3620-56	Kick-starter case cover (GB47 only) ..	1 ..
3623-52	Locating piece, kick-starter case cover ..	1 ..
3623-56	Locating piece, kick-starter case cover (GB47 only)	1 ..
3626-52	Mainshaft nut (kick-starter end)	1 ..
3627-52	Mainshaft bearing (17 mm. x 40 mm. x 12 mm.)	1 ..
3628-52	Bearing retaining ring	1 ..
3630-56	Mainshaft	1 ..
3631-52	Driving sprocket ($\frac{1}{2}$ " x $\frac{1}{8}$ " x 19T)	1 ..
3632-52	Sprocket spacing collar	1 ..
3095-33	Driving gear bearing	1 ..
3634-52	Bearing retaining ring	1 ..
3635-52	Driving gear oil seal	1 ..
3636-52	Driving gear oil seal housing	1 ..
3089-33	Driving gear nut (176X)	1 ..
3091-33	Driving gear lockwasher	1 ..
3637-52	Driving gear bush	2 ..
3638-55	Driving gear c/w bushes (GB47 only) ..	1 ..
3638-52	Driving gear c/w bushes (GB39, GB40 and GB45)	1 ..
3641-52	First gear (mainshaft), 17T	1 ..
3642-52	Second gear (mainshaft), 22T	1 ..
3642-55	Second gear (mainshaft) (GB47 only) ..	1 ..
3643-52	Third gear (mainshaft), 25T	1 ..
3644-52	Second gear layshaft bush and third gear mainshaft bush	2 ..
3648-52	First gear (layshaft), 29T	1 ..
3649-52	Second gear (layshaft), 24T	1 ..
3649-55	Second gear (layshaft) (GB47 only) ..	1 ..
3652-52	Third gear (layshaft), 21T	1 ..
3653-52	Bush, first gear (layshaft)	1 ..
3656-52	Layshaft pinion, 18T	1 ..
3656-55	Layshaft pinion (GB47 only)	1 ..
3657-52	Layshaft	1 ..
3657-55	Layshaft (GB47 only)	1 ..
3658-52	Layshaft bush (clutch end)	1 ..
3659-52	Layshaft bush (kick-starter end)	1 ..
3660-52	Dowel, layshaft bush	2 ..
3661-52	Layshaft cover washer	1 ..
3342-31	Gearbox filler plug	1 ..
3669-52	Gearbox drain plug	1 ..
3670-52	Drain plug washer	1 ..
3671-52	Dowel, gearbox and kick-starter case ..	1 ..
3676-52	Screw, cheese-head ($\frac{1}{4}$ " Whit. x $\frac{7}{8}$ " u/head) ..	2 ..
3676-52	Screw, cheese-head (GB47)	1 ..
3677-52	Screw, cheese-head ($\frac{1}{4}$ " Whit. x $1\frac{1}{8}$ " u/head)	2 ..
3677-52	Screw, cheese-head ($\frac{1}{4}$ " Whit. x $1\frac{1}{8}$ " u/head) (GB47)	4 ..
3678-52	Screw, cheese-head ($\frac{1}{4}$ " Whit. x $1\frac{3}{8}$ " u/head)	4 ..
3678-52	Screw, cheese-head ($\frac{1}{4}$ " Whit. x $1\frac{3}{8}$ " u/head) (GB47)	1 ..
3679-52	Screw, cheese-head ($\frac{1}{4}$ " Whit. x $2\frac{7}{8}$ " u/head)	2 ..
3679-52	Screw, cheese-head ($\frac{1}{4}$ " Whit. x $2\frac{7}{8}$ " u/head)	1 ..
3679-56	Screw, cheese-head ($\frac{1}{4}$ " Whit. x $3\frac{1}{8}$ " u/head) (GB47 only)	1 ..
3670-55	Fibre washer for cheese-head screw ..	2 ..
3342-52	Oil level plug	1 ..

Order by SPARES No.	DESCRIPTION OF PART	No. per Set
3687-52	Oil level plug washer	1 ..
3068-50	Mainshaft nut (clutch end)	1 ..
3070-50	Mainshaft nut lockwasher (clutch end) ..	1 ..
3675-52	Dowel (kick-starter cover locating piece) ..	2 ..
3663-52	Speedometer spindle (except GB47) ..	1 ..
3664-52	Speedometer spindle bush (except GB47) ..	1 ..
3665-52	Speedometer thrust washer (except GB47) ..	1 ..
3160-31	Speedometer location button (except GB47)	1 ..
3666-52	Speedometer oil seal (except GB47) ..	1 ..
3164-31	Speedometer cotter pin (156X) (except GB47)	1 ..
3705-52	Cam assembly	1 ..
3707-52	Cam plunger	1 ..
3709-52	Cam plunger spring	1 ..
3713-52	Cam spindle nut, retaining indicator ..	1 ..
3716-52	Quadrant and peg	1 ..
3718-52	Quadrant spindle	1 ..
3720-52	Quadrant spindle bush (inner)	1 ..
3723-52	Quadrant spindle bush (outer)	1 ..
3725-52	Quadrant spindle cover washer	1 ..
3728-52	Return spring (primary)	1 ..
3733-55	Selector fork (layshaft)	1 ..
3734-55	Selector fork (mainshaft)	1 ..
3738-52	Selector fork cover washer (mainshaft) ..	2 ..
3739-52	Selector fork peg	2 ..
3741-52	Selector fork peg cotter pin	2 ..
3743-52	Quadrant spindle oil seal	1 ..
3746-52	Return spring (secondary)	1 ..
3750-52	Foot change lever	1 ..
3514-33	Bolt for foot change lever	1 ..
3516-33	Nut for 3514-33 bolt	1 ..
3752-52	Washer for 3514-33 bolt	1 ..
3508-33	Foot change lever rubber	1 ..
3756-52	Foot change indicator	1 ..
3758-52	Foot change indicator oil seal	1 ..
3760-52	Cam spindle bush (outer)	1 ..
3763-52	Spring (indicator oil seal)	1 ..
3680-52	Driving ratchet	1 ..
3191-33	Ratchet pinion	1 ..
3196-33	Ratchet pinion spring	1 ..
3683-52	Ratchet pinion bush	1 ..
3325-31	Kick-starter quadrant	1 ..
3686-52	Kick-starter spindle	1 ..
3688-52	Kick-starter spindle bush (inner)	1 ..
3689-52	Kick-starter spindle bush (outer)	1 ..
3335-48	Kick-starter spring	1 ..
3690-52	Kick-starter spring pin	1 ..
3696-52	Kick-starter lever (GB39 and GB40) ..	1 ..
3300-54	Kick-starter lever (GB45)	1 ..
3300-56	Kick-starter lever (GB47)	1 ..
3305-31	Kick-starter lever pedal (GB39 and GB40)	1 ..
3305-54	Kick-starter lever pedal (GB45 and GB47)	1 ..
3307-35	Kick-starter lever pedal rubber	1 ..
3310-37	Kick-starter lever bolt	1 ..
3698-52	Kick-starter lever nut	1 ..
3699-52	Kick-starter spindle oil seal	1 ..
3312-52	Kick-starter lever domed nut (GB45 and GB47)	1 ..
3701-52	Washer for 3310-37 bolt	1 ..
3701-55	Plain washer for 3305-54 pedal	1 ..
3702-55	Spring washer for 3305-54 lever	1 ..

EXPLODED VIEW OF CLUTCH (TYPE GB GEARBOX)

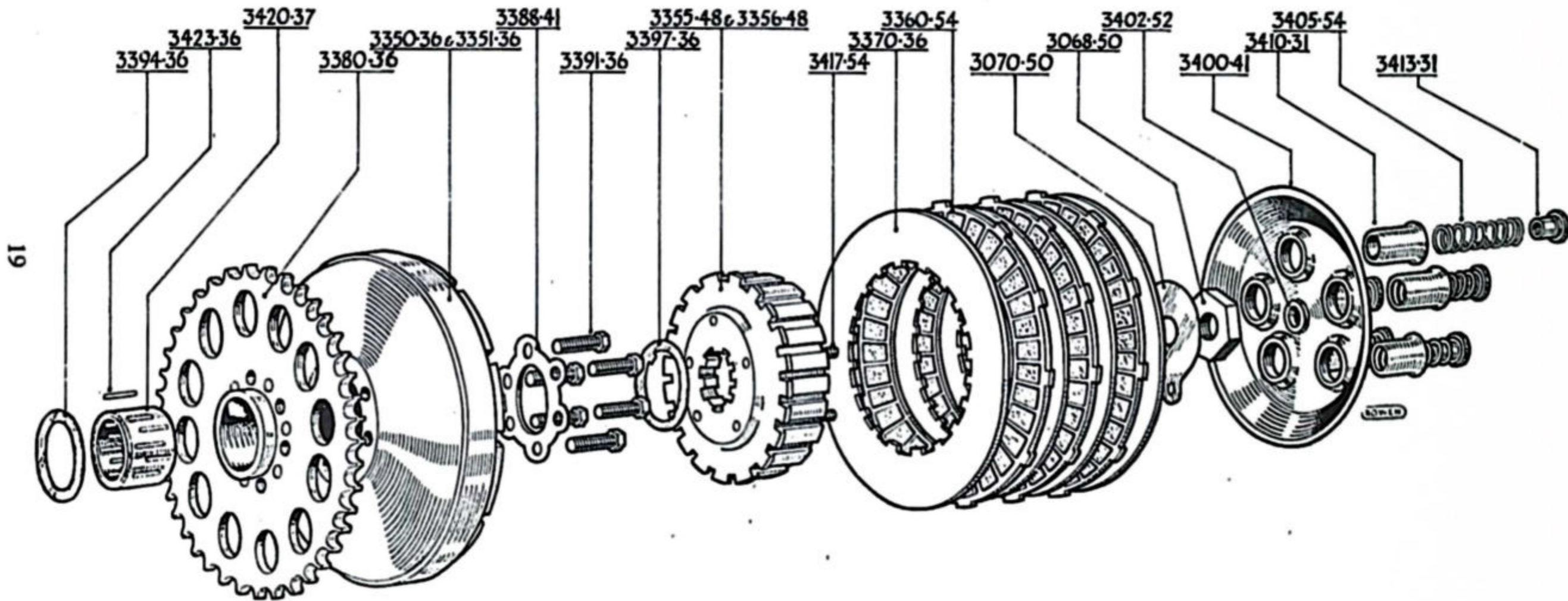

Order by
SPARES
No.

DESCRIPTION OF PART

No.
per Set

3684-55	Tab washer (driving ratchet)	1	..
3766-52	Mainshaft sleeve	1	..
3350-36	Clutch case	1	..
3400-41	Spring plate (GB39, GB40 and GB45)	1	..
3400-56	Spring plate (GB47)	1	..
3402-52	Spring plate thrust cup	1	..
3402-56	Spring plate thrust cup (GB47)	1	..
3405-36	Clutch spring (GB39 and GB40)	5	..
3405-54	Clutch spring (GB45 and GB47)	5	..
3410-31	Spring cup	5	..
3417-54	Spring stud (GB40 and GB45)	5	..
3418-50	Spring stud (GB39 and GB47)	5	..
3413-31	Spring adjusting nut	5	..
3355-48	Clutch centre (GB40 and GB45)	1	..
3356-48	Clutch centre (GB39)	1	..
3370-36	Clutch plate (plain)	3 or 4	..
3360-36	Clutch plate c/w inserts (GB39)	2	..
3360-36	Clutch plate c/w inserts (GB40)	3	..
3360-54	Clutch plate c/w inserts (GB45)	3	..
3360-54	Clutch plate c/w inserts (GB47)	2	..
3365-36	Cork insert for clutch plate (GB39 and GB40)	per doz.	..
3365-54	Clutch plate insert (Klingerite) (GB45 and GB47)	per doz.	..
3380-36	Chain wheel and centre, 44T	1	..
3391-36	Chain wheel set pin	6	..
3394-36	Thrust washer (inner)	1	..
3397-36	Thrust washer (keyed) (outer)	1	..
3388-41	Chain wheel centre tab washer	1	..
3420-37	Clutch roller cage	1	..
3423-36	Needle roller	per doz.	..
3430-56	Clutch operating rod (GB39)	1	..
3433-56	Clutch operating rod (GB40 and GB45)	1	..
3434-56	Clutch operating rod (10 $\frac{5}{16}$ " long) (GB47)	1	..
3770-52C	Clutch operating lever	1	..
3783-52	Clutch operating lever adjusting sleeve	1	..
3784-55	Joint washer for adjusting sleeve cap	1	..
3785-52	Clutch operating lever adjusting sleeve cap	1	..
3788-52	Clutch operating lever adjusting sleeve cap screw	2	..
3790-52	Clutch operating plunger	1	..
3794-52	Clutch lever ball ($\frac{5}{16}$ " dia.)	1	..
3792-52	Clutch cable adjuster	1	..
3793-52	Locknut for cable adjuster	1	..

REAR WHEEL AND HUB

4200-56	Rear wheel c/w brake parts, sprocket and spindle less tyre (NH, VH and VB)	1	..
4203-56	Rear wheel, hub, rim and spokes only, built up (NH, VB and VH)	1	..
4210-56	Rear wheel c/w brake parts, sprocket and spindle, etc., less tyre (HS only)	1	..
4212-56	Rear wheel hub, rim and spokes only, built up (HS only)	1	..
4214-56	Rear wheel c/w brake parts, less tyre (HT only)	1	..
4215-56	Rear hub and studs only	1	..
4217-56	Stud (chain sprocket)	4	..

EXPLODED VIEW OF REAR WHEEL HUB ASSEMBLY

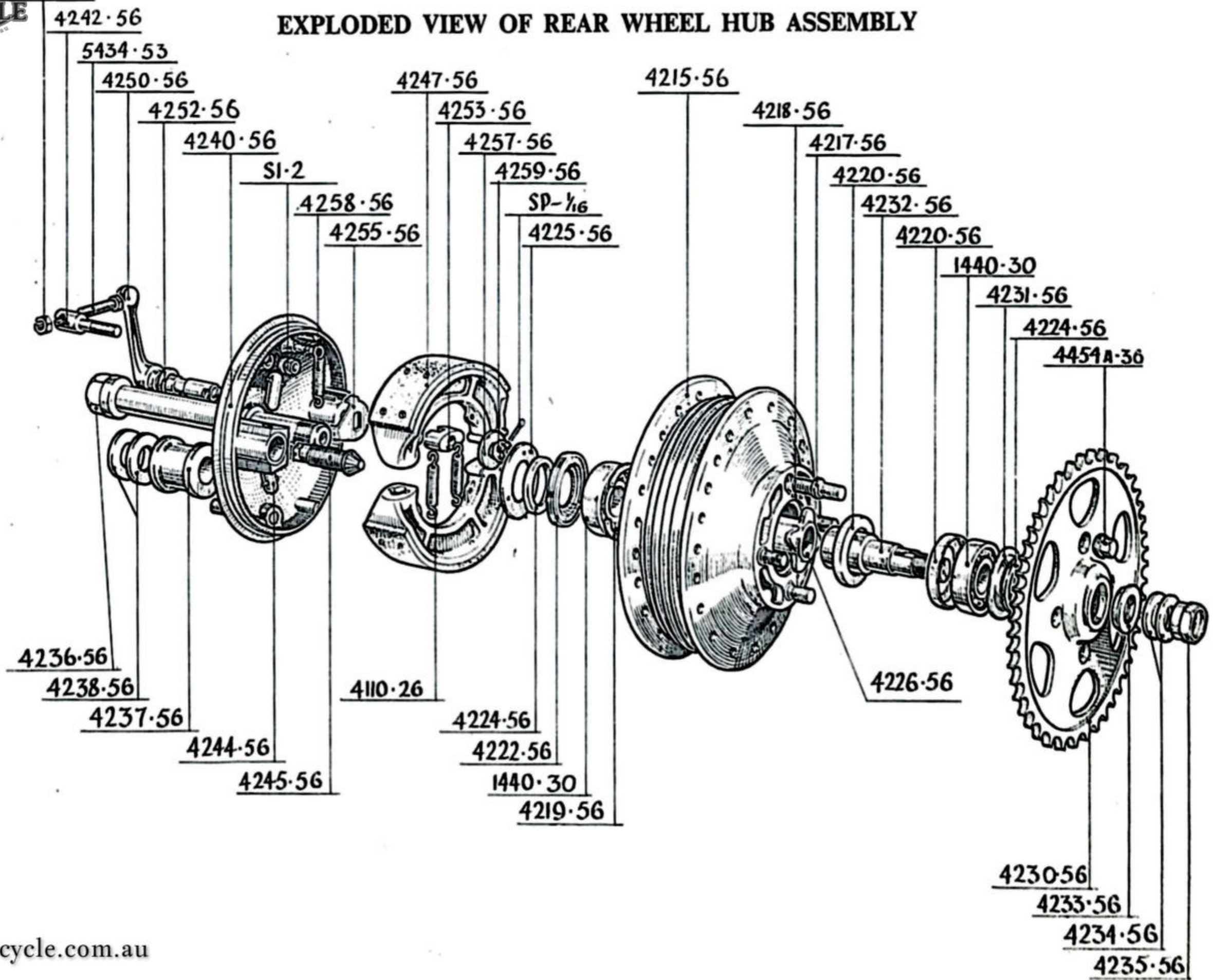

21

Order by SPARES No.	DESCRIPTION OF PART	No. per Set
4218-56	Peg, locking stud (in hub)	4 ..
4219-56	Circlip for bearing (in hub)	1 ..
1440-30	Bearing for hub (RLS8, LJ1 and LS10) ..	1 ..
4220-56	Grease retainer	1 ..
4222-56	Screwed locking ring, R/S	1 ..
4224-56	Felt packing washer, R/S	1 ..
4225-56	Lockplate for screwed ring, R/S	1 ..
4226-56	Spindle distance piece (inside hub) ..	1 ..
4228-56	Rear chain sprocket (HS only)	1 ..
4230-56	Rear chain sprocket (VH, NH and VB) ..	1 ..
1440-30	Bearing for rear chain sprocket (LS10, LJ1 and RLS8)	1 ..
4220-56	Grease retainer (rear sprocket)	1 ..
4224-56	Felt packing washer (rear sprocket) ..	1 ..
4231-56	Retaining plate (rear sprocket)	1 ..
4454A-36	Domed nut securing sprocket to hub (VH, NH and VB)	4 ..
4454-36K	Domed nut securing sprocket to hub (HS)	4 ..
4232-56	Fixed spindle	1 ..
4233-56	Collar for fixed spindle	1 ..
4234-56	Washer for fixed spindle	2 ..
4235-56	Fixed spindle locknut	1 ..
4236-56	Spindle bolt	1 ..
4237-56	Slip collar for spindle bolt	1 ..
4238-56	Washer for spindle bolt	2 ..
4240-56	Brake plate c/w fixed fittings	1 ..
008	Grease nipple (brake plate) (NC6059) ..	1 ..
4242-56	Rear brake cable abutment (brake plate) ..	1 ..
SPW $\frac{1}{16}$	Shakeproof washer for cable abutment ($\frac{1}{16}$ "	1 ..
S1-3	Nut for cable abutment	1 ..
4244-56	Brake wedge and peg	2 ..
4245-56	Adjuster for brake shoes	1 ..
4247-56	Brake shoe c/w lining	2 ..
4110-26	Brake shoe return spring	2 ..
4250-56	Brake lever and cam spindle assembly ..	1 ..
4252-56	Felt washer for cam spindle	1 ..
4253-56	Brake cam	1 ..
4255-56	Stop plate (brake return spring)	1 ..
4257-56	Washer for brake cam spindle	1 ..
4258-56	Brake return spring	1 ..
4259-56	Slotted nut for cam spindle	1 ..
SP $\frac{1}{16}$	Split cotter pin (1" x $\frac{1}{16}$ ")	1 ..
4262-56	Anchor bar	1 ..
	Shakeproof washer ($\frac{7}{16}$ " dia.)	1 ..
12689-54	Nut securing anchor bar to brake plate ..	1 ..
0714	Bolt, anchor bar to frame	1 ..
SPW $\frac{3}{8}$	Shakeproof washer ($\frac{3}{8}$ " dia.)	1 ..
S1-4	Nut for bolt (anchor bar to frame)	1 ..
4264-56	Spoke	40 ..
4266-56	Nipple for spoke	40 ..
4270-56	Rim (WM2-19) (NH, VH and VB)	1 ..
4273-56	Rim (WM3-19) with two security bolts (HS only)	1 ..
4301-56	Rear hub only (HT)	1 ..
4305-32	Chain sprocket, 47T (HT)	1 ..
0522	Bolt for sprocket (HT)	10 ..
4319-29	Lockwasher for 0522 bolt (HT)	10 ..
4320-56	Drive for speedometer drive box (HT) ..	1 ..
4325-39	Grease retainer (pressed in hub, outside bearing) (HT)	1 ..

Order by SPARES No.	DESCRIPTION OF PART	No. per Set
4326-56	Lockring for speedometer drive (HT) ..	1 ..
4329-56	Wheel spindle (HT)	1 ..
4334-39	Wheel spindle nut (HT)	2 ..
4342-39	Ball bearing (HT)	2 ..
4345-56	Disc washer (next bearing in brake drum) (HT)	1 ..
4345-39	Ball bearing abutment washer (inside hub tube), R/S (HT)	1 ..
4352-56	Distance piece (next speedo. gearbox) (HT)	1 ..
0714	Bolt securing anchor bar to frame (HT) ..	1 ..
4375-54	Anchor bar for brake plate (HT)	1 ..
4373-54	Brake plate distance piece (HT)	1 ..
4374-54	Fork end distance piece (HT)	3 ..
4360-54	Brake plate c/w fixed fittings (HT) ..	1 ..
4082-47	Brake fulcrum adjusting wedge (HT) ..	1 ..
4083-46	Brake fulcrum spindle (HT)	2 ..
4383-42	Brake wedge holder (HT)	1 ..
S1-2	Nut securing holder	2 ..
	$\frac{1}{4}$ " shakeproof washer for 4383-42 ..	2 ..
4385-38	Brake shoe half c/w lining (HT)	2 ..
4387-55	Brake lining c/w rivets (HT)	per pair ..
4110-26	Brake shoe return spring	2 ..
4115-46	Brake cam (HT)	1 ..
4118-29	Brake cam washer, loose (HT)	2 ..
4400-54	Brake cam lever (HT)	1 ..
4415-51	Brake cam lever return spring (HT) ..	1 ..
003	Angle grease nipple ($\frac{1}{4}$ " x 26 T.P.I.) (HT) ..	1 ..
S2-3	Nut for brake lever (HT)	1 ..
4476-55	Felt washer (brake drum) (HT)	1 ..
4519-51	Nipple (small type) for spoke (HT) ..	40 ..
4546-51	Spoke (8-10G., butted), brake side (HT) ..	20 ..
4547-56	Spoke (10G., plain), flange side (HT) ..	20 ..
WM2-19	Rim, 40-hole, c/w two security bolts (HT) ..	1 ..

FRONT WHEEL AND HUB ASSEMBLY

4276-56	Front wheel c/w spindle and brake parts, etc., less tyre (rim finished all chrome) (VH, NH and VB)	1 ..
4280-56	Front wheel c/w spindle and brake parts, etc., less tyre (rim finished all chrome) (HS)	1 ..
4281-56	Front wheel c/w spindle and brake parts, etc., less tyre (rim finished all chrome) (HT)	1 ..
4283-56	Front wheel only (hub, rim and spokes built up) (VH, NH and VB)	1 ..
4286-56	Front wheel only (hub, rim and spokes built up) (HS only)	1 ..
4205-56	Front hub only (NH, VH, VB, HS and HT)	1 ..
4219-56	Circlip for bearings	2 ..
1440-30	Bearing for hub (RLS8, LS10 and LJ1) ..	2 ..
4221-56	Sleeve for bearing, R/S	1 ..
4222-56	Screwed lock ring, R/S	1 ..
4045-56	Screwed lock ring, R/S (HT)	1 ..
4052-56	Screwed lock ring, L/S (HT)	1 ..
4224-56	Felt packing washer (large), R/S	1 ..
4223-56	Lockplate for screwed ring, L/S	1 ..
4225-56	Lockplate for screwed ring, R/S	1 ..

EXPLODED VIEW OF FRONT WHEEL HUB ASSEMBLY

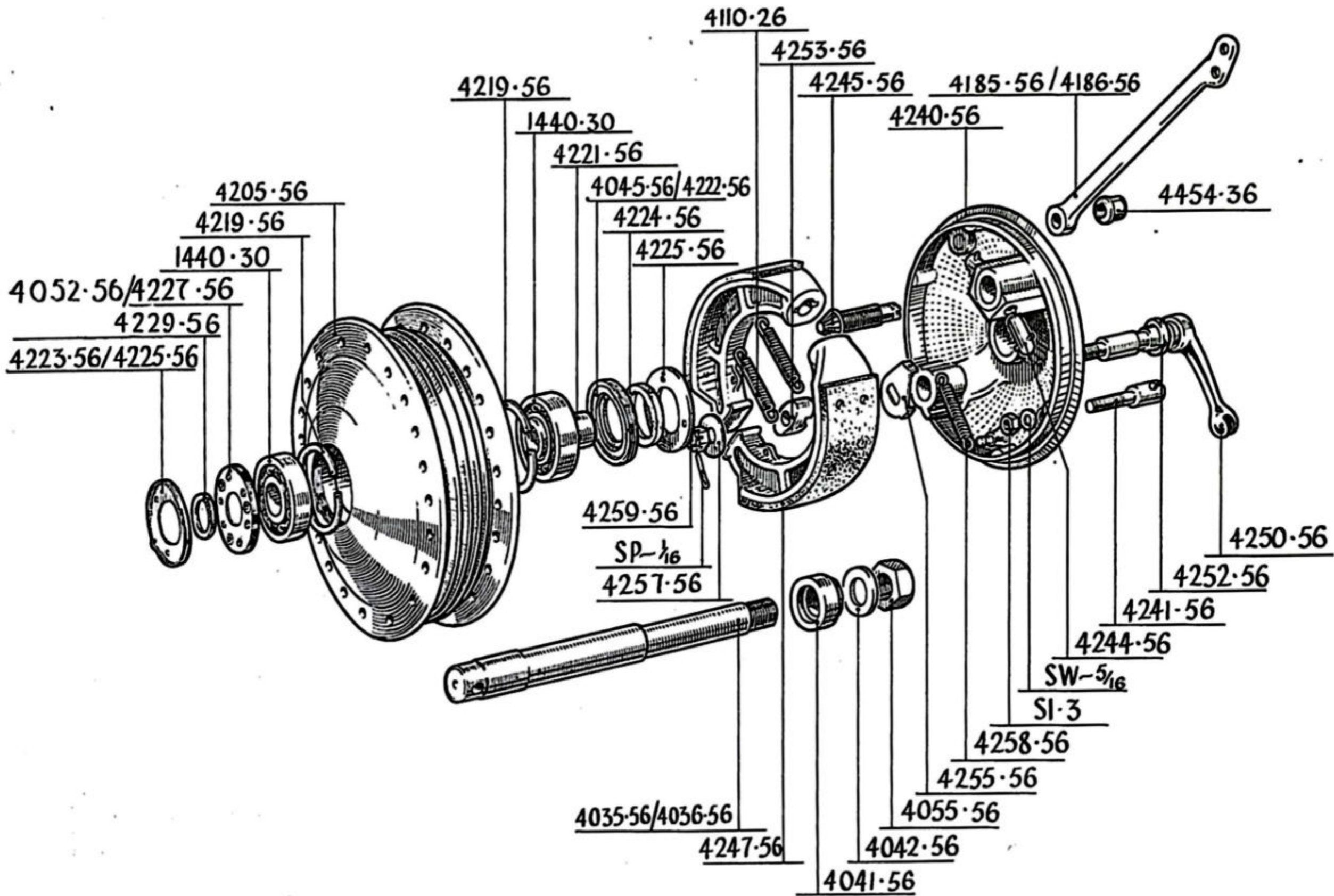

Order by
SPARES
No.

DESCRIPTION OF PART

No.
per Set

4225-56	Lockplate for screwed ring (HT)	2	..
4227-56	Screwed lockring, L/S	1	..
4229-56	Felt packing washer (small), L/S	1	..
4231-56	Retaining plate for felt packing (large) (HT)	1	..
4231B-56	Retaining plate for felt packing (small) (HT)	1	..
4035-56	Hub spindle	1	..
4036-56	Hub spindle (HT)	1	..
4055-56	Hub spindle nut	1	..
4041-56	Distance piece (fork end) R/S	1	..
4042-56	Washer for hub spindle nut	1	..
4240-56	Brake plate c/w fixed fittings	1	..
008	Grease nipple (NC6059) in brake plate ..	1	..
4241-56	Abutment (in brake plate) for brake cable	1	..
SW $\frac{1}{8}$	Shakeproof washer ($\frac{1}{8}$ " dia.)	1	..
S1-3	Nut for abutment	1	..
4244-56	Brake wedge and peg	2	..
4245-56	Adjuster for brake shoes	1	..
4247-56	Brake shoe c/w lining	2	..
4110-26	Brake shoe return spring	2	..
4250-56	Brake lever and cam spindle assembly ..	1	..
4252-56	Felt washer for cam spindle	1	..
4253-56	Brake cam	1	..
4255-56	Stop plate (brake return spring)	1	..
4257-56	Washer for brake cam spindle	1	..
4258-56	Brake return spring	1	..
4259-56	Slotted nut for cam spindle	1	..
SP $\frac{1}{8}$	Split cotter pin (1" x $\frac{1}{8}$ ")	1	..
4185-56	Brake plate anchor bar	1	..
4186-56	Brake plate anchor bar (HT)	1	..
4454-36	Nut securing anchor bar to brake plate ..	1	..
4264-56	Spoke (NH, VH and VB)	40	..
4267-56	Spoke (HS and HT)	40	..
4266-56	Nipple for spoke	40	..
4270-56	Rim (WM2-19), chrome finish	1	..
4272-56	Rim (WM1-21) c/w one security bolt (HS and HT)	1	..

FRONT FORK ASSEMBLY AND FITTINGS

4602-56	Fork assembly c/w cowl and steering damper (sidecar springs) (VB, VH and HS Mk. III)	1	..
4609-56	Fork assembly c/w cowl and steering damper (solo springs) (VH and HS Mk. III) ..	1	..
4611-56	Fork assembly complete (HT)	1	..
4613-56	Fork assembly complete (HS Mk. I)	1	..
4615-56	Fork assembly c/w cowl (NH)	1	..
H2-56	Handlebar bracket	1	..
H3-55	Handlebar bracket (HT only)	1	..
H4-56	Headlamp cowl and instrument panel ..	1	..
H5-54	Fork shaft	2	..
H6-56	Instrument panel for cowl	1	..
H7-56	Bolt for headlamp fixing	2	..
H8-55	Nut for fork shaft (top) (HS Mk. I and HT)	2	..
H9-46	Plug for fork shaft (bottom)	2	..
H14-46	Oil seal	2	..
H15-46	Circlip for top bearing	2	..
H16-54	Top bearing	2	..
H17-49	Lower bearing (fork shaft)	2	..
H18-56	Plug for fork shaft (top) (except HS Mk. I)	2	..

FRONT FORK ASSEMBLY

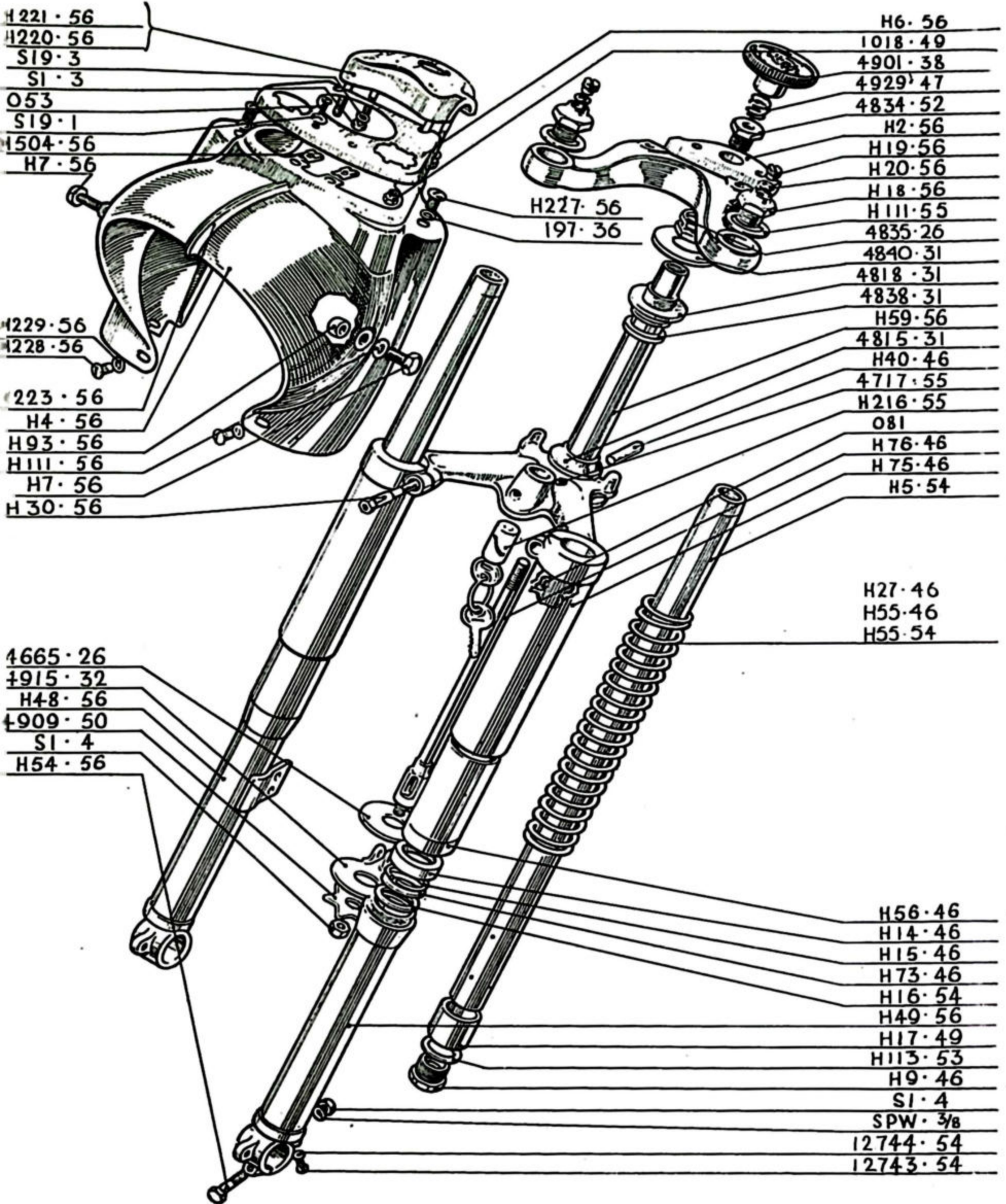

Order by SPARES No.	DESCRIPTION OF PART	No. per Set
H19-56	Filler plug for top plug (fork shaft) ..	2 ..
H20-56	Washer for filler plug	2 ..
H25-55	Top cover (HT only)	2 ..
H27-46	Spring (solo), yellow spot, overall length 10 $\frac{1}{8}$ "-10 $\frac{1}{2}$ " (except VB)	2 ..
H30-56	Pinch bolt, clamping fork shafts in fork crown (VH, NH, VB and HS Mk. III) ..	2 ..
H30-46	Pinch bolt, clamping fork shafts in fork crown (HS Mk. I)	2 ..
H33-56	Clip, securing cables to handlebar bracket	1 ..
H40-46	Fork crown pin (VH, VB and HS) ..	1 ..
H48-56	Sliding tube assembly, R/S	1 ..
H49-56	Sliding tube assembly, L/S	1 ..
H54-56	Bolt for L/S fork end (retaining front wheel spindle)	1 ..
S1-4	Nut for H54-56 bolt	1 ..
SPW $\frac{1}{8}$	Shakeproof washer for H54-56 bolt ($\frac{1}{8}$ " dia.)	1 ..
H55-46	Spring (sidecar), red spot, overall length 9 $\frac{1}{8}$ "-9 $\frac{1}{2}$ " (VH, NH and VB)	2 ..
H55-46	Spring (solo), red spot (VB)	2 ..
H55-54	Spring (sidecar), heavy duty, green spot (VH and VB)	2 ..
H56-46	Oil seal holder complete	2 ..
H59-56	Steering crown and column ..	1 ..
H73A	Shim (top bearing and circlip), .010" thick as reqd.
H73B	Shim (top bearing and circlip), .020" thick as reqd.
H73C	Shim (top bearing and circlip), .030" thick as reqd.
H75-46	Bottom cover and plate assembly	2 ..
081	Screw for H75-46 bottom cover	6 ..
H76-46	Damper bolt assembly (VH, VB and HS) ..	1 ..
H93-56	Distance piece for headlamp fixing ..	2 ..
H111-55	Washer for fork shaft top plug	2 ..
H111-56	Washer for H7-56 bolt	2 ..
H113-53	Washer for lower bearing	2 ..
H220-56	Cap c/w studs, securing handlebar (VH, VB and HS)	1 ..
H221-56	Cap c/w studs, securing handlebar (NH) ..	1 ..
S1-3	Nut securing handlebar cap (VH, VB, NH and HS Mk. III)	3 ..
S1-3	Nut securing handlebar cap (HS Mk. I only)	4 ..
S19-3	Washer for S1-3 nut	4 ..
1018-49	Sleeve nut, securing handlebar cap (VH, NH, VB and HS Mk. III)	1 ..
H223-56	Strip (aluminium) for cowl	1 ..
H225-56	Clip, fixing H223-56 strip to cowl	2 ..
H227-56	Screw (cowl-top fixing)	2 ..
197-36	Washer for H227-56 screw	2 ..
H216-55	Steering lock c/w two keys	1 ..
H228-56	Screw (cowl-front fixing)	2 ..
H229-56	Washer for H228-56 screw	2 ..
H233-56	Screw (cowl-rear fixing)	2 ..
116-38	Washer for H233-56 screw	2 ..
053	Screw securing instrument panel to cowl ..	2 ..
S19-1	Washer for 053 screw	2 ..
H504-56	Captive nut for 053 screw	2 ..
4717-55	Grub screw, securing steering lock (H217) ..	1 ..
4800-55	Steering crown and column (HT)	1 ..

Order by
SPARES
No.

DESCRIPTION OF PART

No.
per Set

4809-56	Steering stop bolt (HT)	2
S1-2	Nut for stop bolt (HT)	2
10214-54	Washer for 12739-54 bolt (HT)	2
10308-54	Nut for 12739-54 bolt (HT)	2
10407-54	Washer for handlebar clip bolt (HT)	4
12615-54	Nut for 4828-55 clamp bolt (HT)	1
12739-54	Bolt for steering crown and column (HT)	2
12743-54	Oil drain screw for fork leg	2
12744-54	Oil drain screw washer	2

STEERING HEAD FITTINGS

4815-31	Ball race for steering crown	1
4815-55	Ball race cone (bottom) (HT)	1
4818-31	Ball race for steering column (top)	1
4818-55	Ball race cone (top) (HT)	1
4820-36	Ball race for frame head lug	2
4820-55	Ball race for frame head lug (HT)	2
S9-2	Steel ball (1/4" dia.) (20 per race)	price per set 40
4828-55	Clamp bolt for handlebar bracket (HT)	1
4833-55	Cap for steering column adjusting sleeve (HT)	1
4834-52	Steering column plug	1
4835-26	Nut for steering column	2
4837-55	Adjusting sleeve for steering column (HT)	1
4838-31	Felt washer	1
4839-55	Clip securing handlebar (HT)	2
4840-31	Dust cover	1
4840-55	Dust cover (HT)	1
4848-55	Bolt for handlebar clip (HT)	4
4850-55	Speedometer bracket (HT)	1
4855-55	Speedometer bracket bolt (HT)	2
4856-55	Washer for 4855-55 bolt (HT)	2
4858-55	Rubber washer for speedometer bracket (HT)	4
4901-38	Steering damper knob (VH, VB and HS)	1
4665-26	Steering damper friction disc (VH, VB and HS)	1
4909-50	Star washer for steering damper (VH, VB and HS)	1
4915-32	Anchor plate for steering damper (VH, HS and VB)	1
4929-47	Spring for damper knob (VH, HS and VB)	1
008	Steering head grease nipple (in frame head lug)	2
0514	Bolt for anchor plate	1
S1-2	Nut for 0514 bolt	1
S1-4	Nut for damper bolt assembly	1

FRONT MUDGUARD AND STAND FITTINGS

4700-56	Mudguard only (HS and HT)	1
4702-56	Mudguard only (plain) (NH and VH)	1
4703-56	Mudguard only (valance) (VB)	1
4705-56	Centre fixing bridge for mudguard (VH, NH and VB)	1
4706-55	Rubber grommet in mudguard for brake cable	1

Order by SPARES No.	DESCRIPTION OF PART	No. per Set
094	Screw securing mudguard to centre fixing bridge	2 ..
S19-2	Washer for 094 screw	2 ..
S1-2	Nut for 094 screw	2 ..
4709-56	Mudguard stay assembly (long) (HS and HT)	1 ..
4710-56	Mudguard stay assembly (short) (HS and HT)	1 ..
0513	Bolt securing stays and centre stay to mudguard (HS and HT)	6 ..
4711-56	Mudguard stay for plain guard (NH and VH)	2 ..
4712-56	Mudguard stay for valanced guard	2 ..
4714-56	Centre stay (HS and HT)	1 ..
0510	Bolt securing stays to guard	2 ..
S19-2	Washer for 0510 bolt	4 ..
S1-2	Nut for 0510 and 094 bolt	2 ..
S1-3	Nut for front stand bolt	2 ..
S6-5	Spring washer for stand bolt	2 ..
S19-3	Plain washer for stand bolt	2 ..
4720-56	Distance piece for front stand bolt	2 ..
4730-56	Front stand (NH, VH and VB)	1 ..
0216	Bolt securing front stand	2 ..
0613	Bolt securing mudguard stay to fork ends (VH, NH and VB)	2 ..
0613	Bolt securing mudguard stay to fork ends (inter. 4733-26) (HS and HT)	4 ..
4733-56	Bolt securing anchor bar and mudguard centre stay to front forks	2 ..
12727-54	Bolt securing anchor bar and mudguard bridge (HT)	2 ..
S19-3	Washer for 4733-26 bolt	4 ..
S1-3	Nut for 4733-26 and 4733-56 bolts	2 ..
10213-54	Nut for 12727-54 bolt	2 ..
0564	Bolt, locking stand	1 ..
0564	Bolt securing centre stay to mudguard	2 ..
S1-3	Nut for 0564 bolt	4 ..
4741-28	Nut for bolt, locking stand	1 ..
4743-53	Plastic moulding for number plate (NH, VH and VB)	1 ..
4744-56	Number plate (HT)	1 ..
4745-56	Front number plate (HS Mk. III)	1 ..
4745-53	Front number plate (VH, NH and VB)	1 ..
S1-2	Nut securing number plate (NH, VH and VB)	2 ..
S19-2	Washer for number plate	2 ..
4746-55	Clip for number plate (HS)	2 ..
4751-55	Screw for number plate (HS)	2 ..
FRAME AND FITTINGS		
4949-56	Frame only, less rear forks (HT)	1 ..
4950-56	Frame only, less rear forks (HS)	1 ..
4953C-56	Frame c/w rear pivoted forks and damper units (NH, VH and VB)	- ..
4953-56	Frame only, less rear forks and damper units (NH, VH and VB)	1 ..
4956-56	Frame stay assembly, R/S (HT)	1 ..
4961-56	Pivoted rear fork assembly c/w flexible bushes (HT)	1 ..

FRAME AND PIVOTED REAR FORK SUSPENSION UNITS

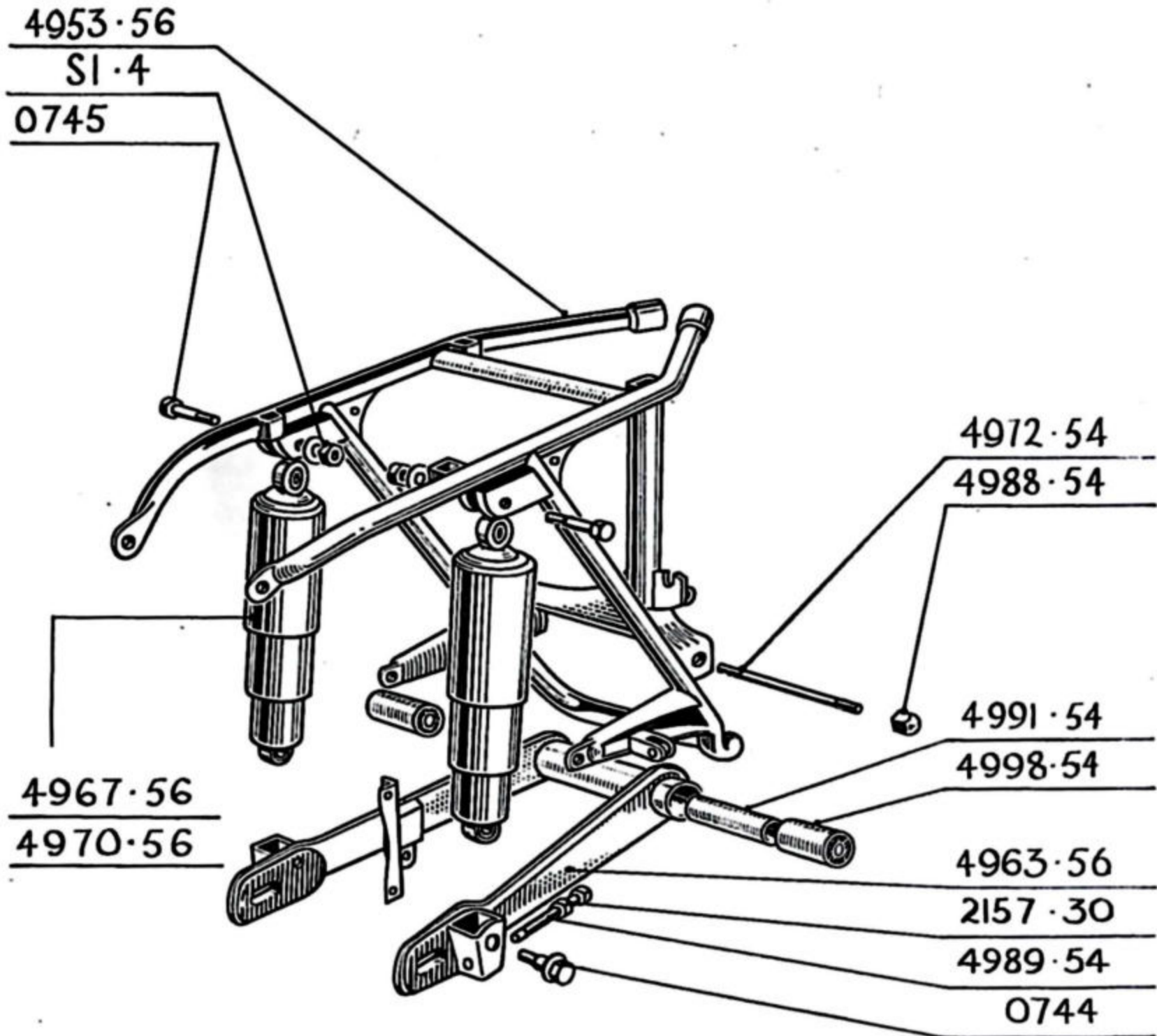

Order by SPARES No.	DESCRIPTION OF PART	No. per Set
4963-56	Pivoted rear fork assembly c/w flexible bushes (VH, NH, VB and HS)	1 ..
4967-56	Rear damper unit (solo) (AT6-7-1096) ..	2 ..
4970-56	Rear damper unit (sidecar) (AT6-7-1096-1)	2 ..
4972-54	Spindle for rear pivoted forks	1 ..
4972-56	Spindle for rear pivoted forks (HT) ..	1 ..
4974-56	Rear damper unit complete (AT6-7-1110) (HT)	2 ..
4976-55	Outer shrouds (AT6-340) for damper unit	2 ..
4977-55	Inner shroud (AT6-339) for damper unit..	2 ..
4978-55	Spring (solo) (AT6-383) for damper unit..	2 ..
4979-55	Spring (sidecar) (AT6-478) for damper unit	2 ..
4981-55	Rubber bush and sleeve (AT6-450 and AT6-447) for end fixing, damper unit ..	4 ..
4983-55	Top abutment (AT6-537)	2 ..
4988-54	Domed nut for 4972-54 spindle	2 ..
4989-54	Rear chain adjuster	2 ..
2157-30	Locknut for 4989-54 adjuster	2 ..
4991-54	Distance tube between flexible bearings ..	1 ..
4991-56	Distance tube between flexible bearings (HT)	1 ..
4993-56	Frame stay assembly, L/S (HT)	1 ..
4998-54	Flexible bearing for rear forks	2 ..
0714	Bolt securing rear frame stay (HS)	2 ..
0744	Bolt fixing damper unit (bottom)	2 ..
0745	Bolt fixing damper unit (top)	2 ..
S1-4	Nut for 0745 bolt	2 ..

PETROL TANK AND FITTINGS

4999-54	Petrol tank (capacity 2½ galls.), less fittings (HS)	1 ..
5000-56	Petrol tank (capacity 4 galls.), less fittings (NH, VH and VB)	1 ..
5000C-56	Petrol tank (capacity 4 galls.), c/w fittings (NH, VH and VB)	1 ..
5004-56	Petrol tank badge (NH, VH, VB and HS)..	2 ..
5004-56A	Petrol tank badge transfer (HT only) ..	2 ..
5007-56C	Petrol tank complete (HT)	1 ..
5007-56	Petrol tank only (HT)	1 ..
5009-56	Surround for petrol tank badge (NH, VH and VB)	2 ..
088	Screw for tank badge	4 ..
050	Screw for tank badge (HS)	4 ..
5011-54	Filler cap complete (No. 10183) (HS) ..	1 ..
5012C-56	Filler cap complete (NH, VH and VB) ..	1 ..
5015-56	Flute c/w fixing springs for petrol tank per pair	..
5019-55	Petrol tank bolt (HT)	2 ..
5050-55	Petrol tap and strainer (¼" B.S.F. two-level)	1 ..
5051-54	Petrol tap (7838J) (HS)	1 ..
5054-27	Petrol tap washer for 5050-55 tap	2 ..
5055-54	Petrol tap (¼" gas, B. & S.) (HT)	1 ..
5057-54	Distance tube for tank fixing bolt (NH, VH and VB)	4 ..
0579	Tank fixing bolt (⅜" × 1½" × 18 T.P.I.) (NH, VH and VB)	4 ..
5058-26	Tank fixing bolt steel washer (NH, VH and VB)	4 ..
5058-26	Tank fixing bolt steel washer (HS)..	2 ..
5058-55	Washer for petrol tank stud (HS and HT)	1 ..

Order by SPARES No.	DESCRIPTION OF PART	No. per Set
5060-31	Rubber packing ($\frac{3}{8}$ " thick) for tank bolt (HS)	3 ..
5060-31	Rubber washer ($\frac{3}{8}$ " thick) for tank bolt (NH, VH and VB)	4 ..
5060-27	Rubber packing ($\frac{3}{8}$ " thick) for tank bolt (VH, NH and VB)	4 ..
5060-54	Rubber packing washer (1" thick) for tank bolt (HT)	3 ..
5061-54	Rubber packing washer ($\frac{3}{8}$ " thick) for tank bolt (HT)	1 ..
5062-55	Rubber packing (1 $\frac{1}{4}$ " thick) for tank bolt and stud (HS)	3 ..
5068-55	Petrol pipe complete (VH)	1 ..
5069-50	Petrol pipe complete (HS and HT)	1 ..
5071-55	Petrol pipe complete (NH)	1 ..
5073-55	Petrol pipe complete (VB)	1 ..
5082-53	Knee grip, R/S (NH, VH and VB)	1 ..
5083-53	Knee grip, L/S (NH, VH and VB)	1 ..
0545	Screw securing knee grip	4 ..
5094-54	Distance tube for front tank fixing bolts (HS)	2 ..
0312	Stud fixing petrol tank (rear) (HS)	1 ..
0583	Bolt fixing petrol tank (front) (HS)	2 ..
	Pinnacle nut ($\frac{3}{8}$ " B.S.F.) for 0312 stud (HS and HT)	1 ..
S19-4	Washer for 5019-55 bolt (HT)	2 ..
S3-4	Castle nut for 5019-55 bolt (HT)	2 ..
	Split pin (1" x $\frac{3}{16}$ ") (HT)	2 ..
0316	Tank fixing stud (HT)	1 ..

SPEEDOMETERS

5200-56	Speedometer head, 120 m.p.h. (NH, VH, VB and HS Mk. III)	1 ..
5201-56	Speedometer head, 180 k.p.h. (NH, VH, VB and HS Mk. III)	1 ..
5213-56	Strap securing speedometer head to cowl (NH, VH, VB and HS Mk. III)	1 ..
5226-52	Speedometer cable complete (NH, VH, VB and HS Mk. III)	1 ..
12767-55	Speedometer cable complete (HT)	1 ..
12766-55	Speedometer head complete (HT)	1 ..
12768-55	Speedometer gearbox for rear wheel (HT)	1 ..

FOOTREST, BRAKE PEDAL, ROD AND CABLE

5376-56	Footrest support, L/S (NH, VH, VB and HS Mk. III)	1 ..
5377-54	Tie bolt for footrest support (NH, VH, VB and HS Mk. III)	1 ..
5380-56	Footrest support, R/S (NH, VH, VB and HS Mk. III)	1 ..
5382-56	Footrest (HT only)	1 ..
5383-56	Footrest, R/S and L/S (NH, VH, VB and HS Mk. III)	2 ..
S3-5	Slotted nut securing footrest (NH, VH, VB and HS Mk. III)	2 ..
5385-54	Distance tube for 5377-54 tie bolt	1 ..
5386-56	Footrest, R/S (HS Mk. I only)	1 ..

Order by SPARES No.	DESCRIPTION OF PART	No. per Set
5387-56	Footrest, L/S (HS Mk. I only)	1 ..
5388-56	Footrest rod (HS Mk. I only)	1 ..
5390-54	Sleeve nut securing footrest bracket to tie bolt (NH, VH, VB and HS Mk. III)	2 ..
0445	Stud securing footrest to frame (3¼" x ½" x 20 T.P.I.) (HS Mk. I)	2 ..
12691-54	Footrest rubber pad	2 ..
S19-6	Washer for S1-6 nut (HS Mk. I)	6 ..
S1-6	Nut securing footrest (HS Mk. I)	6 ..
0714	Bolt securing footrest to frame (HT)	4 ..
	Shakeproof washer for 0714 bolt	4 ..
S1-4	Nut for 0714 bolt	4 ..
5400-56	Rear brake pedal (NH, VH, VB and HS Mk. III)	1 ..
5401-56	Rear brake pedal (HS Mk. I)	1 ..
5404-56	Rear brake pedal (HT)	1 ..
S1-4	Nut securing brake pedal (HT)	1 ..
5412-51	Brake pedal spindle (NH, VH, VB and HS)	1 ..
S2-6	Locknut for 5412-51 spindle	1 ..
5419-56	Swivel piece for brake rod	1 ..
5420-56	Spring for stop light switch (NH, VH and VB)	1 ..
5425-56	Brake rod (5" x ¼" dia.) (NH, VH, VB and HS)	1 ..
5427-55	Rear brake rod (HT)	1 ..
5428-56	Rear brake cable complete (NH, VH, VB and HS)	1 ..
5429-54	Clip complete, stop light spring to brake cable (NH, VH and VB)	1 ..
5430-36	Jaw joint for brake rod (NH, VH, VB, HS and HT)	1 ..
S48-2	Joint pin for jaw joint	2 ..
S17-1	Split pin for S48-2 joint pin	2 ..
S2-2	Locknut for brake rod jaw joint	1 ..
5429-56	Circlip securing swivel piece to brake pedal (1400/.375)	1 ..
5434-53	Brake cable adjuster (NH, VH, VB and HS)	1 ..
5435-31	Wing nut for brake rod (HT)	1 ..
5435-53	Locknut for cable adjuster	1 ..
5436-36	Sleeve for brake rod (HT)	1 ..
5437-36	Swivel pin for brake jaw joint (HT)	1 ..
5438-56	Brake pedal return spring (NH, VH, VB and HS)	1 ..
5440-56	Bell crank lever for brake rod and brake cable (NH, VH, VB and HS)	1 ..
5441-56	Bolt securing bell crank lever	1 ..
5443-56	Washer for 5441-56 bolt	1 ..
098	Screw fixing stop light switch	2 ..
S2-1	Nut for 098 screw	2 ..

PILLION FOOTRESTS

5541-32	Rubber pad for footrest (NH, VH, VB and HS Mk. III)	2 ..
5542-28	Footrest bar (NH, VH, VB and HS Mk. III)	2 ..
5547-28	Washer for footrest screw	2 ..
07	Screw for footrest bar	2 ..
S2-4	Nut for 07 screw	2 ..

Order by
SPARES
No.

DESCRIPTION OF PART

No.
per Set

REAR MUDGUARD AND FITTINGS

5574-56	Rear mudguard (HT)	1	..
5574-54	Rear mudguard (HS)	1	..
5580-55	Rear mudguard (NH, VH and VB) ..	1	..
5058-26	Washer for 0207 bolt	2	..
0207	Bolt securing tailguard to frame (NH, VH and VB)	2	..
5595-56	Rear guard stay, R/S (HT)	1	..
5596-56	Rear guard stay, L/S (HT)	1	..
094	Screw, bracket to mudguard (HS) ..	6	..
S1-2	Nut for 094 screw	6	..
5600-55	Rear support bracket (HS)	1	..
5601-56	Support bridge (Dural) for mudguard (HT)	1	..
5602-55	Centre support bracket (HS)	1	..
5605-56	Top bridge (chromed) for mudguard (HT)	1	..
5607-54	Distance piece, mudguard to frame bracket (HS)	1	..
0607	Bolt for distance piece (HS)	1	..
5611-55	Rear number plate lamp mounting (NH, VH and VB)	1	..
5645-56	Rear number plate (HT)	1	..
5645-55	Rear number plate (HS Mk. III)	1	..
094	Screw, rear number plate to mudguard (HS)	2	..
0510	Bolt securing number plate to mudguard (HS)	1	..
0510	Bolt securing stays to mudguard (HT) ..	4	..
5647-55	Rear number plate (NH, VH and VB) ..	1	..
5058-26	Washer (large) for 0510 bolt	1	..
5061-26	Rubber distance piece for number plate (HS)	1	..
094	Bolt securing top bridge to mudguard (HT)	2	..
0745	Bolt securing top bridge and stays to seat stay lug (HT)	2	..
5650-53	Moulding for rear number plate (NH, VH and VB)	1	..
5660-55	Bolt and spire nut securing number plate to mudguard (SSO-1835) (NH, VH and VB)	2	..
5670-55	Ariel name plate c/w clips (NH, VH and VB)	1	..
5671-56	Rear number plate support (HT)	1	..
5672-56	Bolt securing rear tailguard to mudguard and front fixing rear mudguard ..	4	..
5673-56	Spire nut for 5672-56 bolt	4	..

CHAINS AND CHAIN COVERS

5702-54	Clutch dome (NH, VH, VB, HS and HT) ..	1	..
041	Screw (cheese-head, $\frac{1}{4}$ " x $\frac{1}{8}$ " x 20 T.P.I.) for clutch dome	3	..
5709-55	Washer between inner chain cover and and crankcase	1	..
5710-54	Oil bath chain case (outer half)	1	..
5711-56	Oil bath chain case (back half)	1	..
0510	Plug for inner chain case (HT and HS Mk. I)	1	..
5184-36	Washer for 0510 plug	1	..
S1-2	Nut for 0510 plug	1	..
015	Screw (cheese-head, $\frac{1}{4}$ " x 1" x 20 T.P.I.) ..	9	..
017	Screw (cheese-head, $\frac{1}{4}$ " x $1\frac{1}{2}$ " x 20 T.P.I.) ..	1	..
043	Screw (cheese-head, $\frac{1}{4}$ " x $\frac{11}{8}$ " x 20 T.P.I.) ..	1	..
0138	Stud for front section rear chain case, lower fixing (NH, VH, VB and HS Mk. III) ..	1	..

Order by
SPARES
No.

DESCRIPTION OF PART

No.
per Set

6043-53	Bolt fixing chain guard, front (HT)	1	..
5720-56	Rear chain guard (NH, VH and VB)	1	..
5721-56	Rear chain guard, front section (NH, VH and VB)	1	..
5722-56	Rear chain guard (HS)	1	..
5723-56	Spire nut for 5721-56 chain guard..	1	..
5725-56	Rear chain guard (HT)	1	..
0526	Bolt securing front section of chain guard to primary chain case	1	..
0554	Bolt ($\frac{1}{4}$ " \times $\frac{3}{8}$ " \times 26 T.P.I.), front fixing, rear chain guard (NH, VH, VB and HS)	2	..
0566	Bolt fixing chain guard, rear (HT)..	1	..
094	Screw ($\frac{1}{8}$ " \times $\frac{3}{8}$ " \times 26 T.P.I.) securing front section rear chain guard (VB, NH and VH)	2	..
0512	Bolt, rear fixing, chain guard to frame (NH, VH, VB and HS)	1	..
5729-56	Distance piece for 0512 bolt	1	..
5739-56	Rubber grommet for oil pipe, front section rear chain guard (NH, VH and VB)	1	..
5742-56	Oil pipe for front section rear chain guard (NH, VH and VB)	1	..
139-53	Rubber connection for connecting 5742-56 oil pipe to oil tank (NH, VH and VB)	1	..
052	Screw ($\frac{1}{8}$ " \times 2 $\frac{1}{8}$ " \times 26 T.P.I.) for rear fixing (NH, VH, VB and HS)	2	..
S1-3	Nut for 052 screw	2	..
5750A-32	Inspection plug (NH, VH, VB, HS and HT)	1	..
5751-31	Washer for inspection plug..	1	..
5753-56	Lockwasher for 0526 bolt	1	..
5760-54	Washer between two halves of chain case (NH, VH, VB, HS and HT)	1	..
5760A-50	Felt washer (round hole) for primary chain cover (HT and HS Mk. I)	1	..
5760B-50	Felt washer (hexagon hole) for primary chain cover (HT and HS Mk. I)	1	..
041	Drain screw (NH, VH, VB, HS and HT)..	1	..
5765-54	Drain screw washer	1	..
5767-39	Chain case oil level plug	1	..
2101-30	Washer for oil level plug	1	..
051	Screw, chain case to crankcase	3	..
053	Screw, outer cover oil hole plug (NH, VH, VB, HS and HT)	1	..
12744-54	Washer for 053 screw	1	..
5781-54	Front chain ($\frac{1}{2}$ " \times .305" \times 72 pitches) (NH, HT and HS Mk. I)	1	..
5785-53	Front chain ($\frac{1}{2}$ " \times .305" \times 71 pitches), solo (VH and VB)	1	..
5785-53A	Front chain ($\frac{1}{2}$ " \times .305" \times 73 pitches), sidecar (VH and VB)	1	..
5785-53A	Front chain ($\frac{1}{2}$ " \times .305" \times 73 pitches) (HS Mk. III)	1	..
5790-54	Rear chain ($\frac{3}{8}$ " \times $\frac{3}{8}$ " \times 100 pitches) (NH, VH, VB and HS)	1	..
5790-56	Rear chain ($\frac{3}{8}$ " \times $\frac{3}{8}$ " \times 96 pitches) (HT)	1	..
REAR CHAIN CASE			
5745-56	Rear chain case complete (NH, VH and VB)	1	..
5752-56	Rear chain case (top section) (NH, VH and VB)	1	..

5758-56	Rear chain case (bottom section) (NH, VH and VB)	1	..
5721-56	Rear chain case (front section) (NH, VH and VB)	1	..
5723-56	Spire nut for 5721-56 chain case	1	..
5769-56	Rear section for chain case (NH, VH and VB)	1	..
094	Screw ($\frac{1}{4}$ " \times $\frac{1}{2}$ " \times 26 T.P.I.) securing front and rear section chain case (VH, NH and VB)	4	..
S19-2	Washer for 094 screw	4	..
5739-56	Oil pipe rubber grommet for front section of rear chain guard (VH, NH and VB)	1	..
5742-56	Oil pipe, front section rear chain case (fits in 5739-56)	1	..
5775-56	Rubber grommet (plain) for bottom section rear chain case (NH, VH and VB)	2	..
139-53	Rubber connection, oil tank to 5742-56 oil pipe for rear chain lubrication (NH, VH and VB)	1	..
0526	Bolt securing front section rear chain case to primary chain case (NH, VH and VB)	1	..
5753-56	Lockwasher for 0526 bolt	1	..
0554	Bolt, front fixing, rear chain case	4	..
052	Screw ($\frac{5}{16}$ " \times $2\frac{5}{16}$ " \times 26 T.P.I.), rear fixing, chain case (NH, VH and VB)	2	..

OIL TANK AND FITTINGS

5850-56	Oil tank (NH, VH, VB and HS Mk. III)	1	..
5851-56	Oil tank (HT)	1	..
5853-56	Oil tank (HS Mk. I)	1	..
5854-29	Filler cap complete with washer	1	..
5854-56	Filler cap complete (Type P1645) (HS Mk. I)	1	..
5855-29	Filler cap washer	1	..
5861-56	Oil filter complete (NH, VH, VB, HT and HS Mk. III)	1	..
5861-37	Oil connection complete (HS Mk. I)	1	..
5867-56	Oil pipe and swivel connection (HS Mk. I)	1	..
5874-55	Flexible oil pipe complete (delivery and return) (NH, VH, VB, HS and HT)	2	..
5874-56	Flexible oil pipe (delivery) (HS Mk. I)	1	..
5875-56	Bolt for oil tank top steady (HS Mk. I)	1	..
5882-56	Flexible oil pipe (return) (HS Mk. I)	1	..
5895-37	Washer for delivery union	2	..
5897-35	Clip complete for 5900-55 cap	1	..
5898-30	Drain plug	1	..
5899-30	Drain plug washer	1	..
5900-55	Rubber cap (rocker feed junction pipe) (VB)	1	..
0513	Bolt securing oil tank to frame (NH, VH, VB, HT and HS Mk. III)	2	..
S19-2	Washer for 0513 bolt	2	..
S1-2	Nut for 0513 bolt	2	..
0582	Bolt for oil tank steady clip	1	..
S1-3	Washer for 0582 bolt	1	..
5058-26	Washer (large) for rubber washer (HS Mk. I)	2	..
5060-27	Rubber washer for oil tank (top) (HS Mk. I)	1	..
5060-31	Mounting rubber for oil tank (HS Mk. I)	4	..
12673-54	Bolt ($1\frac{1}{2}$ " \times $\frac{5}{16}$ " B.S.F.) (HS Mk. I)	2	..
SN-3	$\frac{5}{16}$ " B.S.F. pinnacle nut (HS Mk. I)	2	..

EXHAUST PIPES AND SILENCERS

6000-55	Exhaust pipe and bracket (VB)	1 ..
6001-56	Exhaust pipe and bracket (VH and HS Mk. III)	1 ..
6006-56	Exhaust pipe and bracket (HS Mk. I)	1 ..
6007-56	Exhaust pipe (HT)	1 ..
6011-56	Exhaust pipe and bracket (NH)	1 ..
6035-54	Silencer (VH, VB and HS Mk. III)	1 ..
6036-56	Silencer (carbjetor) (HT)	1 ..
6037-54	Silencer (NH)	1 ..
6061-33	Clip complete (cylinder head to exhaust pipe joint) (VH and HS Mk. III)	1 ..
6062-29	Clip complete (silencer to exhaust pipe joint) (VH, VB and HS Mk. III)	1 ..
6062-55	Clip complete (cylinder head to exhaust pipe joint) (VB)	1 ..
6063-29	Clip complete (exhaust pipe to silencer) (NH and HT)	1 ..
0618	Screw for head joint clip (VB)	1 ..
0540	Screw for head joint clip (VH and HS Mk. III)	1 ..
6063-56	Clip complete (exhaust pipe to head joint) (NH)	1 ..
6070-29	Pin for clip (6062-29 and 6063-29)	1 ..
6072-29	Swivel piece for clip (6062-29 and 6063-29)	1 ..
6075-56	Clip (exhaust pipe to frame, rear fixing) (HS)	1 ..
6083-56	Stay for holding silencer (HT)	1 ..
S1-2	Nut for 6070-29 pin	1 ..
0714	Bolt (silencer fixing) (HT)	1 ..
0311	Bolt securing exhaust pipe and silencer to frame	1 ..
S1-4	Nut for 0311 bolt	1 ..
015	Screw for 6063-56 clip	1 ..
5723-31	Nut for 015 screw	1 ..

BATTERY CARRIER AND FITTINGS

6107-56	Battery strap (NH, VH, VB and HS Mk. III)	1 ..
6109-43	Swivel pin (short) for top battery strap (NH, VH, VB and HS (Mk. III)	1 ..
0544	Bolt for battery strap	1 ..
049	Screw securing battery platform on chain-case (NH, VH, VB and HS Mk. III)	2 ..
0182	Stud (top fixing), battery carrier to frame (NH, VH, VB and HS Mk. III)	1 ..
5860-51	Nut for 0182 stud	2 ..
6151-56	Battery platform (NH, VH, VB and HS Mk. III)	1 ..
5723-56	Nut securing battery strap	1 ..
6158-56	Bolt securing horn bracket to tool box bracket	2 ..
6169-56	Distance tube for horn bracket	2 ..
0516	Set bolt for voltage control	2 ..

Order by
SPARES
No.

DESCRIPTION OF PART

No.
per Set

DUALSEAT

6200-55	Dualseat complete (NH, VH, VB and HS)	1	..
6215-56	Bolt securing dualseat (SS0-1965-10-00) (HS Mk. I)	3	..
6215-56	Bolt securing dualseat (SS0-1965-10-00) (NH, VH, VB and HS Mk. III)	4	..
6216-55	Spire nut for dualseat (SNL 1000)	4	..
S19-3	Washer for 6215-56 bolt	3	..

SADDLE

6201-56	Saddle c/w springs (HT)	1	..
0593	Bolt securing saddle (HT)	1	..
0714	Bolt for saddle anchorage (HT)	2	..

HANDLEBARS AND FITTINGS

6400-56	Handlebar c/w horn push and harness (NH, VH and VB)	1	..
6402-56	Handlebar (colonial type) c/w horn push and harness	1	..
6404-54	Handlebar (HS)	1	..
H102-55	Handlebar (HT)	1	..
6406-56	Dummy grip (No. 5005)	1	..
6414-56	Clutch and magneto lever control assembly complete (HS and HT)	1	..
6415-56	Clutch and magneto lever control assembly complete (NH, VH and VB)	1	..
6416-56	Front brake and air control lever assembly complete (NH, VH and VB)	1	..
6415B-56	Clutch lever only	1	..
6416B-56	Front brake lever only	1	..
6418-56	Valve lifter lever complete (No. 105) (NH, VH, VB and HS)	1	..
6418M-56	Exhaust lifter trigger complete (HT)	1	..
6421-56	Front brake and air control lever assembly complete (HS and HT)	1	..
6425D-56	Twist grip rubber (No. 619) (HS)	1	..
6425-56A	Twist grip rubber (No. 676) (NH, VH and VB)	1	..
6429-56	Twist grip complete (No. 67) (NH, VH and VB)	1	..
6430-56	Twist grip complete (No. 61) (HS and HT)	1	..

CONTROL CABLES

6449-56	Magneto cable complete (HT)	1	..
6450-56E	Magdyno cable complete (colonial bars)	1	..
6450-56	Magdyno cable complete (NH, VH, VB and HS Mk. III)	1	..
6451-56	Magneto cable complete (HS Mk. I)	1	..

Order by
SPARES
No.

DESCRIPTION OF PART

No.
per Set

6463-56	Clutch cable complete (NH, VH, VB and HS)	1	..
6463-56E	Clutch cable complete (colonial type handlebars only) (NH, VH and VB)	1	..
6464-56	Clutch cable complete (HT)	1	..
6470-56	Exhaust lifter cable complete (NH, VH, VB and HS)	1	..
6470-56E	Exhaust lifter cable complete (colonial type handlebars) (NH, VH, VB, HS and HT)	1	..
6479-56	Front brake cable complete (NH, VH, VB, HS and HT)	1	..
6479-56E	Front brake cable complete (colonial type handlebars only) (HS, NH, VH and VB)	1	..
6489-56	Throttle cable complete (NH)	1	..
6489-56E	Throttle cable complete (colonial type handlebars) (NH)	1	..
6490-56	Throttle cable complete (VH and HT)	1	..
6490-56E	Throttle cable complete (colonial type handlebars) (VH)	1	..
6491-56	Throttle cable complete (VB)	1	..
6491-56E	Throttle cable complete (colonial type handlebars) (VB)	1	..
6492-56	Throttle cable complete (HS)	1	..
6501-56	Air cable complete (NH)	1	..
6501-56E	Air cable complete (colonial type handlebars) (NH)	1	..
6502-56	Air cable complete (VH and HT)	1	..
6502-56E	Air cable complete (colonial type handlebars) (VH)	1	..
6503-56	Air cable complete (VB)	1	..
6503-56	Air cable complete (colonial type handlebars) (VB)	1	..
6504-56	Air cable complete (HS)	1	..

TOOL BOX AND TOOL KIT

6554-56	Tool box complete (HT)	1	..
6555-54C	Tool box complete with fittings (NH, VH, VB and HS Mk. III)	1	..
6557-41	Thumb screw for tool box	1	..
12675-56	Bolt securing tool box (HT)	2	..
12676-54	Washer for 12675-56 bolt (HT)	2	..
6600-32	Spanner for brake adjustment	1	..
6600-36	Spanner ($\frac{1}{8}$ " B.S.F. \times $\frac{1}{4}$ " B.S.F.)	1	..
6603-28	Spanner ($\frac{1}{16}$ " B.S.F. \times $\frac{3}{8}$ " B.S.F.)	1	..
6603-56	Double-ended spanner (rear wheel spindle nut)	1	..
6604-28	Tappet spanner (VB)	1	..
6604-55	Tappet spanner (VH, NH, HS and HT)	1	..
6605-28	Spanner ($\frac{1}{16}$ " B.S.F. \times $\frac{1}{2}$ " B.S.F.)	1	..
6606-27	Spanner for steering head nut	1	..
6608-56	Spanner for sparking plug	1	..
6611-55	Box spanner for rear wheel	1	..
6611-31	Double-ended box spanner	1	..
6616-26	Screwdriver	1	..
6616-29	Screwdriver for clutch spring nuts	1	..
6617-26	Magneto spanner (460076)	1	..
6621C-29	Sprocket extractor, set pin and adaptor complete	1	..

Order by SPARES No.	DESCRIPTION OF PART	No. per Set
6625-26	Tyre lever	1 ..
6625-55	Tyre lever and tommy bar	1 ..
6636-54	Tyre inflator	1 ..
6640-54	Tool roll only	1 ..
6683-56	Set of tools complete with tool roll, S.V. (VB)	1 ..
6687-56	Set of tools complete with tool roll, O.H.V. (VH, NH, HS and HT)	1 ..

Note. Set of tools does not include tyre inflator or sprocket extractor.

CARBURETTER

Makers: AMAL LTD.,
Holdford Road, Witton, Birmingham 6.

376/8	Carburetter complete with cables, less controls, 350 c.c. (NH) ..	
376/11	Carburetter complete with cables, less controls, 500 c.c. (VH and HT)	
376/13	Carburetter complete with cables, less controls, 600 c.c. (VB) ..	
389	Carburetter complete with cables, less controls, 500 c.c. (HS) ..	
376/002	Mixing chamber body (NH and VB)	
376/003	Mixing chamber body (VH and HT)	
389/00	Mixing chamber body (HS)	
376/056	Jet block, 1" bore (NH and VB)	
376/057	Jet block, 1 1/8" bore (VH and HT)	
389/055	Jet block (HS)	
376/064	Mixing chamber top (VB and NH)	
376/099	Mixing chamber top (VH and HT)	
376/065	Ring for mixing chamber top	
4/035	Cable adjuster (NH and VH)	
376/060	Throttle valve (376/3 1/2) (NH, VH, HT and VB)	
376/061	Throttle valve spring	
376/063	Taper needle (VH, NH, VB and HT)	
389/063	Taper needle (HS)	
4/230	Needle clip	
376/062	Air valve	
389/062	Air valve (HS)	
6/047	Air valve guide	
29/057	Air valve guide (HS)	
4/046	Air valve spring	
376/072	Needle jet	
376/100	Main jet (state size)	
376/073	Main jet holder	
376/074	Washer for jet holder	
376/075	Main jet cover nut	
376/076	Pilot jet	
376/095	Nut for pilot jet	
116/162	Washer for 376/095 nut	
332/017	Air adjusting screw	
4/148	Spring for 332/017 screw	
376/068	Throttle stop screw	
376/069	Spring for 376/068 screw	
376/083	Float complete	
376/089	Float needle	
376/090	Banjo (single)	
14/175	Banjo washer	
376/091	Banjo bolt	
376/092	Washer for banjo bolt	
376/086	Tickler	

Order by
SPARES
No.

DESCRIPTION OF PART

No.
per Set

343/011	Tickler body
376/087	Tickler spring
376/077	Float chamber cover
376/078	Float chamber cover joint
376/079	Screw for float chamber cover
376/093	Filter gauze

AIR CLEANER

9000-54C	Air cleaner complete (VB)	1	..
9000-55C	Air cleaner complete (NH, VH and HS Mk. III)	1	..
9000-56C	Air cleaner complete (HS Mk. I)	1	..
9001-55	Rubber connector for air cleaner (NH)	1	..
9005-55	Rubber connector for air cleaner (VH, HS Mk. III and HT)	1	..
9009-56	Air cleaner complete (HT)	1	..
9021-55	Rubber connector for air cleaner (VB)	1	..
9026-56	Connector for air cleaner (HS Mk. I)	1	..

FRONT CRASH BARS

9200-56	Front crash bar assembly (NH, VH and VB)	1	..
9200C-56	Front crash bar assembly complete with fittings (VH, NH and VB)	1	..
9206-56	Distance piece (top fixing)	2	..
9208-56	Stud, crash bar (top fixing)	1	..
9210-56	Stud, crash bar (lower fixing)	1	..
S19-5	Washer for top fixing stud	2	..
S1-5	Nut for top fixing stud	2	..

ELECTRICAL EQUIPMENT

Makers: Messrs. JOSEPH LUCAS LTD. (Service Dept.),
Great King Street, Birmingham 19 and
Great Hampton Street, Birmingham 18

51818B	Headlamp complete (NH, VH and VB)
51819B	Headlamp complete (Export Europe, not France)
51820B	Headlamp complete (Export France)
112201	Bolt for headlamp fixing
36084F	Ammeter
137141	Washer for headlamp fixing bolt
37127H	Control box
70136A	Horn
31563A	Horn push and dipper switch
KN.R1.42157K	Magneto (Lucas racing type) (HS Mk. I)
46028B	Magdyno
516798	Light unit
516801	Light unit (Export Europe, not France)
516802	Light unit (Export France)
403	Bulb, main (Export Europe, not France)
988	Bulb, pilot
53432B	Stop and tail lamp
PUZ7E-9	Battery
31340A	Lighting switch
200737	Brush set (Magdyno)
220197	Brush tension spring set
200731	Field coils, set

STANDARD NUTS AND WASHERS

Order by SPARES No.	DESCRIPTION OF PART					
S1-2	Nut (standard), $\frac{1}{4}$ " dia. × 26 T.P.I.	}
S1-3	Nut (standard), $\frac{5}{16}$ " dia. × 26 T.P.I.	
S1-4	Nut (standard), $\frac{3}{8}$ " dia. × 26 T.P.I.	}
S1-5	Nut (standard), $\frac{7}{16}$ " dia. × 26 T.P.I.	
S1-6	Nut (standard), $\frac{1}{2}$ " dia. × 26 T.P.I.	
S2-2	Locknut (thin), $\frac{1}{4}$ " dia. × 26 T.P.I.	}
S2-3	Locknut (thin), $\frac{5}{16}$ " dia. × 26 T.P.I.	
S2-4	Locknut (thin), $\frac{3}{8}$ " dia. × 26 T.P.I.	}
S2-5	Locknut (thin), $\frac{7}{16}$ " dia. × 26 T.P.I.	
S2-6	Locknut (thin), $\frac{1}{2}$ " dia. × 26 T.P.I.	
S2-7L	Locknut (thin), $\frac{9}{16}$ " dia. × 20 T.P.I., L.H., bright	..				
S6-3	Double spring washer	}
S6-6	Double spring washer	
S9-1	Steel ball, $\frac{3}{16}$ " dia.	}
S9-1A	Steel ball, $\frac{7}{32}$ " dia.	
S9-2	Steel ball, $\frac{1}{4}$ " dia.	
S17-1	Split pin, $\frac{1}{16}$ " dia. × $\frac{3}{8}$ "	}
S18-1	No. 3 Woodruff key	}
S18-2	No. 9 Woodruff key	
S19-2	Plain washer, $\frac{1}{4}$ " dia. hole	}
S19-3	Plain washer, $\frac{5}{16}$ " dia. hole	
S19-4	Plain washer, $\frac{3}{8}$ " dia. hole	}
S19-5	Plain washer, $\frac{7}{16}$ " dia. hole	
S19-6	Plain washer, $\frac{1}{2}$ " dia. hole	
S21-1	Oil pipe union body	
S48-2	Joint pin	
S51-1	Joint pin, battery strap	