

BRITCYCLE
www.britcycle.com.au



SPARES

**A50 CYCLONE ROAD MODEL
A50 CYCLONE COMPETITION MODEL
A65 THUNDERBOLT ROCKET
A65 LIGHTNING ROCKET
A65 SPITFIRE HORNET**

www.britcycle.com.au

Catalogue No. 5118

CATALOGUE OF



A50 Cyclone Road Model.

A65 Thunderbolt Rocket.

A50 Cyclone Competition Model. A65 Lightning Rocket.

A65 Spitfire Hornet.

ISSUED BY

B.S.A. MOTOR CYCLES LTD.

Service Department, Armoury Road,
Birmingham 11

TELEPHONE - - BIRMINGHAM VICTORIA 2381

TELEGRAMS - - - "SELMOTO" BIRMINGHAM

B.S.A. MOTOR CYCLES LTD.

Registered Offices and Works: ARMOURY ROAD, BIRMINGHAM 11

Telephones: BIRMINGHAM VICTORIA 2381

Telegrams and Cables: "SELMOTO BIRMINGHAM"

Contractors to Her Majesty's Government, the War Office, the Admiralty, the Post Office, the Colonial and Foreign Governments

B.S.A. PRESS

SUFFIX NUMBER TO BE USED TO IDENTIFY VARYING FINISHES.
CHIFFRES DE SUFFIXE A EMPLOYER POUR IDENTIFIER LES PRESENTATIONS VARIÉES.
NACHZAHLEN ZU BENUTZEN UM DIE VERSCHIEDENEN AUSFÜHRUNGEN ZU BEZEICHNEN.
CIFRAS ADICIONALES QUE SE EMPLEA PARA IDENTIFICAR LOS ACABADOS VARIOS.

When ordering components with varying finishes, please state finish required by adding the APPROPRIATE NUMBER TO PART NUMBER.

En commandant des pièces avec présentations différentes veuillez indiquer la présentation requise en ajoutant les chiffres appropriés au numéro de CATALOGUE DE LA PIÈCE.

Bei Bestellungen von Teilen mit verschiedenen Ausführungen bitte die Erwünschte Ausführung mit Angabe der entsprechenden Nachzahl nach dem TEILNUMMER BEZIECHNEN.

Al pedir piezas con acabados diferentes sírvase indicar el acabado requerido mediante la cifra relativa escrita después del NUMERO DE CATALOGO DE LA PIEZA.

EXAMPLE. Petrol Tank Flamboyant Blue, Chrome Panels and Single White Line 87 68-8003/174.

/007	Black	/165	Silver	/174	Flamboyant Blue	/170	Flamboyant Red
/003	Chrome	/202	Mandarine Red		and Chrome.	/176	Flamboyant Red
/208	Red and Black		and Chrome.	/201	Mandarine Red		and Chrome.

PISTON CHART, TABLEAU DES PISTONS, KOLBENTABELLE, GRAFICO DE EMBOLAS

Model Modèle Typen Modelos	Compression Ratio Taux de compression Kompression Compresion	PISTON COMPLETE PISTON COMPLET KOLBEN KOMPLETT EMBOLA COMPLETO			COMPRESSION RING SEGMENT DE COMPRESSION KOMPRESSIONS-RING ANILLO DE COMPRESION			PISTON RING (BOTTOM) SEGMENT (INFERIOR) KOLBENRING (UNTER) SEGMENTO (INFERIOR)		
		Standard Montante	+ 1/2 mm.	+ 1 mm.	Standard Montante	+ 1/2 mm.	+ 1 mm.	Standard Montante	+ 1/2 mm.	+ 1 mm.
A50	8.5	1 54 68-0453	1 54 68-0455	1 54 68-0457	1 14 68-0238 1 17 68-0354	1 16 68-0297 1 17 68-0355	1 16 68-0298 1 17 68-0356	1 18 68-0299	1 18 68-0300	1 18 68-0301
A50	9.0	1 52 68-0434	1 52 68-0435	1 52 68-0438	1 14 68-0296 1 17 68-0354	1 16 68-0297 1 17 68-0355	1 16 68-0298 1 17 68-0356	1 18 68-0299	1 18 68-0300	1 18 68-0301
A50	10.0	1 60 68-0505	1 60 68-0507	1 60 68-0509	1 14 68-0296 1 17 68-0354	1 16 68-0297 1 17 68-0355	1 16 68-0298 1 17 68-0356	1 18 68-0299	1 18 68-0300	1 18 68-0301
A65	8.0	1 52 68-0427	1 52 68-0429	1 52 68-0431	1 16 68-0256 1 17 68-0357	1 16 68-0257 1 17 68-0358	1 16 68-0258 1 17 68-0359	1 17 68-0259	1 17 68-0260	1 17 68-0261
A65	9.0	1 54 68-0484	1 54 68-0486	1 54 68-0488	1 16 68-0256 1 17 68-0357	1 16 68-0257 1 17 68-0358	1 16 68-0258 1 17 68-0359	1 17 68-0259	1 17 68-0260	1 17 68-0261
A65	11.0	1 62 68-0568	1 62 68-0570	1 62 68-0572	1 16 68-0256 1 17 68-0357	1 16 68-0257 1 17 68-0358	1 16 68-0258 1 17 68-0359	1 17 68-0259	1 17 68-0260	1 17 68-0261

**SPEEDOMETER GEARS, COMMANDE DE COMPTEUR, GESCHWINDIGKEITS-
MESSANTRIEB**

**MANDO DEL
CUENTAKILOMETROS**

Model Modèle Typen Modelos	Spares No. No. de pièce Ersatzteil-Nr. No. de repuesto	Description	Designation	Beschreibung	Descripción
A65T/R Solo †19 68-3134	Driving Gear (7T)	Pignon de commande (D-7)	Antriebzahnrad (Z-7)	Piñón de mando (D-7)
A65L/R Solo †27 68-3135	Driven Gear (10T)	Pignon de renvoi (D-10)	Angetriebenes (Z-10)	Piñón de cambio (D-10)
A65T/R, S/C 19 68-3131	Driving Gear (7T)	Pignon de commande (D-7)	Antriebzahnrad (Z-7)	Piñón de mando (D-7)
 †7 68-3132	Driven Gear (12T)	Pignon de renvoi (D-10)	Angetriebenes (Z-10)	Piñón de cambio (D-10)
A65T/R Solo *19 68-3146	Driving Gear (8T)	Pignon de commande (D-8)	Antriebzahnrad (Z-8)	Piñón de mando (D-8)
 *27 68-3147	Driven Gear (12T)	Pignon de renvoi (D-12)	Angetriebenes (Z-12)	Piñón de cambio (D-12)
A65T/R †19 68-3148	Driving Gear (6T)	Pignon de commande (D-6)	Antriebzahnrad (Z-6)	Piñón de mando (D-6)
 †27 68-0314	Driven Gear (11T)	Pignon de renvoi (D-11)	Angetriebenes (Z-11)	Piñón de cambio (D-11)
A65S/H 19 68-3143	Driving Gear (7T)	Pignon de commande (D-7)	Antriebzahnrad (Z-7)	Piñón de mando (D-7)
A50C 27 68-3144	Driven Gear (11T)	Pignon de renvoi (D-11)	Angetriebenes (Z-11)	Piñón de cambio (D-11)
A65L/R Solo 19 68-3140	Driving Gear (8T)	Pignon de commande (D-8)	Antriebzahnrad (Z-8)	Piñón de mando (D-8)
 27 68-3141	Driven Gear (11T)	Pignon de renvoi (D-11)	Angetriebenes (Z-11)	Piñón de cambio (D-11)
		*After Engine No. A65C - 502	*Monté depuis moteur numéro A65C - 502.	*Montiert nach Motor Nummer A65C - 502.	*Montada después de motor numero A65C - 502.
		†After Engine No. A65D - 615	†Monté depuis moteur numéro A65D - 615.	†Montiert nach Motor Nummer A65D - 615.	†Montada después de motor numero A65D - 615.
		‡With Chronometric Speedometer.	‡Equipe d'un compteur de vitesses chronometrique.	‡Mit einem Chronometrischen Tachometer Ausgerüstet.	‡Equipado con un tacometro cronométrico.

CARBURETTORS, CARBURATEURS, VERGASER, CARBURADORES

AMAL LTD., HOLFORD ROAD, WITTON, BIRMINGHAM, ENGLAND.

Model Modèle Typen Modelos	Spares No. No. de pièce Ersatzteil-Nr. No. de repuesto	Makers No. No. du fabricant Hersteller-Nr. No. fabricante	Main Jet Gicleur principal Hauptdüse Surtidor principal	Pilot Jet Gicleur de ralenti Leerlaufdüse Surtidor piloto	Throttle Slide Boisseau des gaz Gassscheiber Corredera de aceleración	Needle Jet Gicleur d'aiguille Nadeldüse Suridor de aguja	Needle Position Position d'aiguille Nadelstellung Posición de aguja
A50C EAST COAST	19-7090	376-316	170	25	376/3½	.106	2
A50C WEST COAST	19-7084	376-310	180	25	376/3½	.106	3
A65L/R	19-7082	389/206	220	25	389/3½	.106	3
A65S/H	19-7082	389/206	220	25	389/3½	.106	3
A65T/R	19-7081	389/202	310	25	389/3½	.106	3

ASSEMBLIES COMPLETE, ENSEMBLE COMPLET, TIELE-MONTAGE KOMPLETT, ASEMBLI COMPLETO

Model Modèle Typen Modelos		Spares No. No. de pièce Ersatzteil-Nr. No. de repuesto	Description	Designation	Beschreibung	Descripción
A50C Competition ...	†	68-0459	Engine complete less Carburettor.	Moteur complet sans appareillage électrique et carburateur.	Motor komplett ohne Elektr. Ausrüstung und ohne Vergaser.	Motor completo sin equipo eléctrico y carburador.
A50C ROAD MODEL ...	†	68-0460	Engine complete less Carburettor.	Moteur complet sans appareillage électrique et carburateur.	Motor komplett ohne Elektr. Ausrüstung und ohne Vergaser.	Motor completo sin equipo eléctrico y carburador.
A50C (close ratio gears) ...		68-0459	Engine complete less Carburettor.	Moteur complet sans appareillage électrique et carburateur.	Motor komplett ohne Elektr. Ausrüstung und ohne Vergaser.	Motor completo sin equipo eléctrico y carburador.
A50C (std. ratio gears) ...		68-0460	Engine complete less Carburettor.	Moteur complet sans appareillage électrique et carburateur.	Motor komplett ohne Elektr. Ausrüstung und ohne Vergaser.	Motor completo sin equipo eléctrico y carburador.
A65T/R		68-0525	Engine complete less Carburettor.	Moteur complet sans appareillage électrique et carburateur.	Motor komplett ohne Elektr. Ausrüstung und ohne Vergaser.	Motor completo sin equipo eléctrico y carburador.
A65T/R	*	68-0526	Engine complete less Carburettor.	Moteur complet sans appareillage électrique et carburateur.	Motor komplett ohne Elektr. Ausrüstung und ohne Vergaser.	Motor completo sin equipo eléctrico y carburador.
A65S/H (std. gear ratio) ...		68-0463	Engine complete less Carburettor.	Moteur complet sans appareillage électrique et carburateur.	Motor komplett ohne Elektr. Ausrüstung und ohne Vergaser.	Motor completo sin equipo eléctrico y carburador.
A65S/H (close ratio gears)		68-0462	Engine complete less Carburettor.	Moteur complet sans appareillage électrique et carburateur.	Motor komplett ohne Elektr. Ausrüstung und ohne Vergaser.	Motor completo sin equipo eléctrico y carburador.
A65L/R		68-0461	Engine complete less Carburettor.	Moteur complet sans appareillage électrique et carburateur.	Motor komplett ohne Elektr. Ausrüstung und ohne Vergaser.	Motor completo sin equipo eléctrico y carburador.
A50C, A65T/R, L/R, S/H		86 68-3206	Clutch complete	Embrayage complet	Kupplung komplett	Embrague completo
A50C		90 68-0618	Crankshaft and Flywheel Assembly.	Vilebrequin et volant complet.	Kurbelwelle und Schwungmasse komplett.	Cigüeñal y volante completo
A65T/R, L/R, S/H ...		90 68-0615	Crankshaft and Flywheel Assembly.	Vilebrequin et volant complet.	Kurbelwelle und Schwungmasse komplett.	Cigüeñal y volante completo
A65L/R, S/H, A50C ...	†	68-4146	Frame complete	Cadre complet	Rahmen komplett	Cuadro completo
A65L/R, S/H, A50C ...		98 68-4134	Frame complete	Cadre complet	Rahmen komplett	Cuadro completo
A65T/R		97 68-4129	Frame complete	Cadre complet	Rahmen komplett	Cuadro completo
A50C		96 42-5146	Front Fork complete	Fourche avant complet	Vordergabel komplett	Horquilla delantera completo
A50C Competition ...	†	96 42-5146	Front Fork complete	Fourche avant complet	Vordergabel komplett	Horquilla delantera completo
A65T/R	†	97 68-5111	Front Fork complete	Fourche avant complet	Vordergabel komplett	Horquilla delantera completo
A65T/R		96 68-5071	Front Fork complete	Fourche avant complet	Vordergabel komplett	Horquilla delantera completo
A65S/H		97 42-5147	Front Fork complete	Fourche avant complet	Vordergabel komplett	Horquilla delantera completo
A50C ROAD MODEL, A65L/R	†	97 68-5110	Front Fork complete	Fourche avant complet	Vordergabel komplett	Horquilla delantera completo
A65L/R		96 68-5070	Front Fork complete	Fourche avant complet	Vordergabel komplett	Horquilla delantera completo
A50C, A65S/H, L/R ...		84 42-5513	Front Wheel complete	Roue avant complet	Vorderrad komplett	Rueda delantera completo
A65T/R		88 68-5506	Front Wheel complete	Roue avant complet	Vorderrad komplett	Rueda delantera completo

ASSEMBLIES COMPLETE, ENSEMBLE COMPLET, TIELE-MONTAGE KOMPLETT, ASEMBLI COMPLETO

Model Modèle Typen Modelos	Spares No. No. de pièce Ersatzteil-Nr. No. de repuesto	Description	Designation	Beschreibung	Descripción
A50C, A65S/H	89 68-6052	Rear Wheel complete	Roue arrière complet	Hinterrad komplett	Rueda trasera completo
A65T/R	89 68-6001	Rear Wheel complete	Roue arrière complet	Hinterrad komplett	Rueda trasera completo
A65L/R	89 68-6050	Rear Wheel complete	Roue arrière complet	Hinterrad komplett	Rueda trasera completo
A50C, A65L/R, S/H ...	77 42-5538	Front Hub complete	Moyeau de roue avant complet	Vorderradnabe komplett	Cuebo de rueda delantera completo.
A65T/R	79 42-5805	Front Hub complete	Moyeau de roue avant complet	Vorderradnabe komplett	Cuebo de rueda delantera completo.
A50C, A65L/R, S/H ...	76 67-6136	Rear Hub complete	Moyeau de roue arrière complet.	Hinterradnabe komplett	Cuebo de rueda trasera
A65T/R	82 68-6005	Rear Hub complete	Moyeau de roue arrière complet.	Hinterradnabe komplett	Cuebo de rueda trasera completo.
A50C, A65T/R, L/R, S/H	53 68-0282	Oil Pump complete	Pompe à huile complet	Ölpumpe komplett	Bomba de aceite
		*When Magnetic Speedometer is fitted. †1965 models.	*Equipé d'un compteur de vitesses magnetique. †1965 modèles.	*Ausgerüstet mit Magnetischen Geschwind. †Typen 1965.	*Equipado con un indicador de velocidad magnetico. †Modelos 1965.

INDEX, GRUPPEVERZEICHNIS, INDICE

				Page Seite Pagina
Cylinder Head Rocker Box	Culasse Boîtier des culbuteurs	Zylinderkopf Kipphebelkasten	Culata Carter de los brazos oscilantes	10 - 11
Cylinder Head Exhaust Pipes	Culasse Tuyau d'échappement	Zylinderkopf Auspuffrohr	Culata Tubo de escape	12 - 13
Cylinder Valves	Cylindre Soupape	Zylinder Ventil	Cilindro Valvula	14 - 15
Crankshaft	Vilebrequin	Kurbelwelle	Ciguñal	16 - 17
Crankcase	Carter de vilebrequin	Kurbelgehäuse	Caja de ciguñal	18 - 19
Oil Pump	Pompe à huile	Ölpumpe	Bomba de aceite	20 - 21
Gear Cluster Camshaft	Jeu d'engrenages Arbre de cames	Zahnradsatz Nockenwelle	Juego de engranajes Arbol de levas	22 - 25
Gearchange Mechanism	Mécanisme de changement de vitesses.	Schaltung	Cambio	26 - 27
Footstart Footchange	Kickstarter Selecteur au pied	Kickstart Fusschaltung	Arrancador Cambio de pie	28 - 31
Clutch Primary Cover	Embrayage Couvercle primaire	Kupplung Primarkappe	Embrague Tapa primario	32 - 35
Frame	Cadre	Rahmen	Cuadro	36 - 37
Frame	Cadre	Rahmen	Cuadro	38 - 39
Swinging Arm Shock Absorber	Bras oscillant Amortisseur	Schwingarm Stossdämpfer	Horquilla oscilante Amortiguador	40 - 43
Oil Tank Toolbox Silencer	Réservoir d'huile Coffret à outils Silencieux	Öltank Werkzeugkasten Schalldämpfer	Deposito de aceite Caja de herramientas Silenciador	44 - 47

INDEX, GRUPPEVERZEICHNIS, INDICE

				Page Seite Pagina
Steering	Direction	Lenkung	Dirección	48 - 49
Front Forks	Fourche avant	Vordergabel	Horquilla delantera	50 - 51
Front Wheel	Roue avant	Vorderrad	Rueda delantera	52 - 55
Rear Wheel	Roue arrière	Hinterrad	Rueda trasera	56 - 61
Mudguards Chainguard	Garde-boue Carter de chaîne	Schutzblech Kettenschutz	Guardabarros Guardacadena	62 - 67
Handlebar Controls Dual Seat Petrol Tank	Guidon Commandes Selle double Réservoir d'essence	Lenker Bedienungshebel Doppelsitz Benzintank	Manillar Mandos Asiento doble Deposito de combustible	68 - 75
Electrical Equipment	Equipement électrique	Elektr. Ausrüstung	Equipo eléctrico	76 - 79
Tools	Outils	Werkzeuge	Herramientas	80 - 81

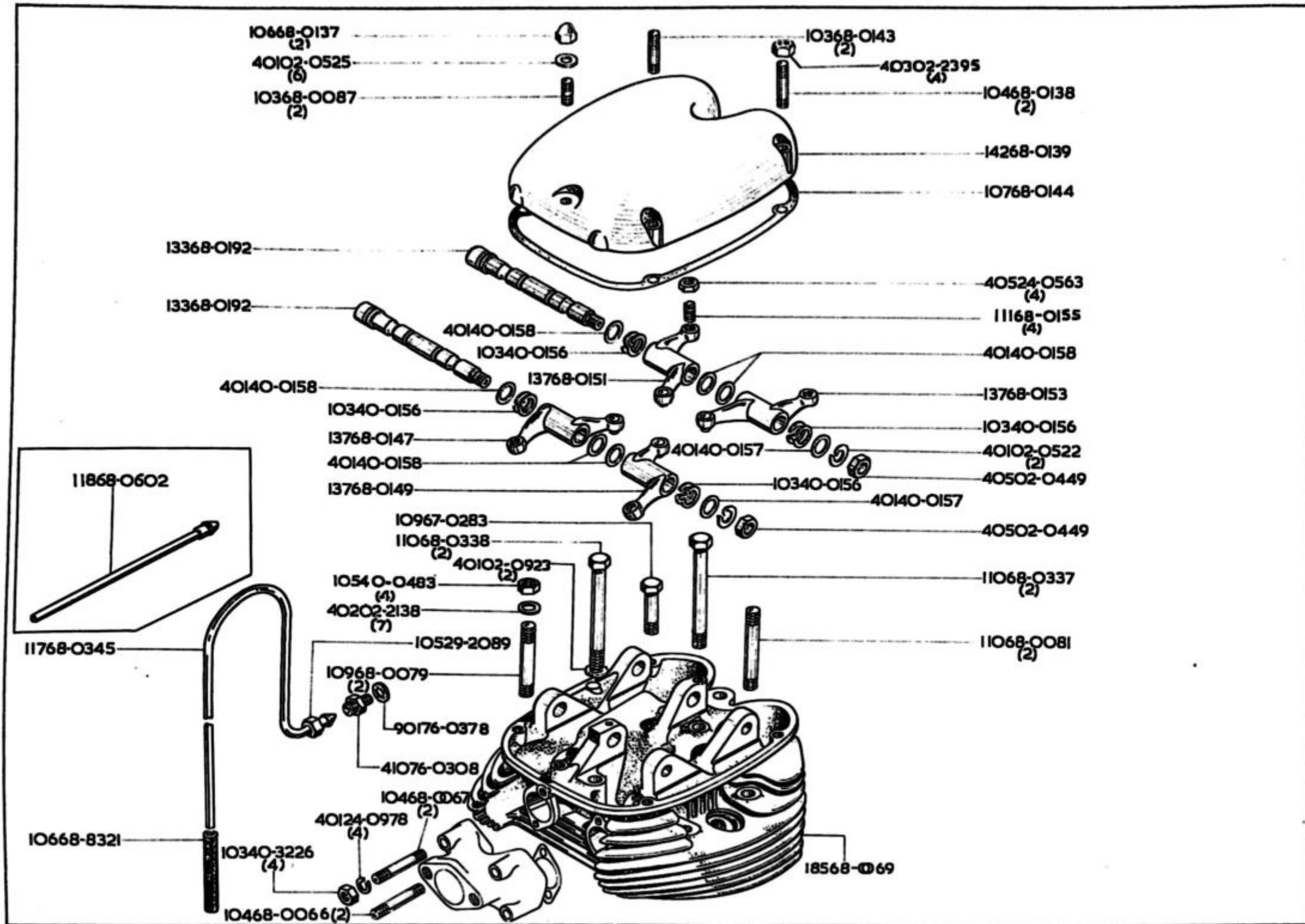

CYLINDER HEAD, CULASSE, ZYLINDERKOPF, CULATA

Model Modèle Typen Modelos	Spare No. No. de pièces Ersatzteil-Nr. No. de repuesto	Description	Designation	Beschreibung	Descripción
A65T/R, L/R, S/H, A50C	05 02-0449	Spindle Nut	Écrou	Mutter	Tuerca
	01 02-0522	Spindle Washer	Rondelle	Scheibe	Arandela
	01 02-0525	Washer	Rondelle	Scheibe	Arandela
	01 02-0923	Washer	Rondelle	Scheibe	Arandela
	02 02-2138	Washer	Rondelle	Scheibe	Arandela
	03 02-2395	Rocker Box Nut	Écrou	Mutter	Tuerca
	05 24-0563	Adjuster Nut	Écrou de réglage	Stellmutter	Tuerca de ajuste
A65T/R	01 24-0978	Lockwasher	Rondelle frein	Sicherung	Freno
	05 29-2089	Union Nut	Écrou de raccord	Mutter	Tuerca
	03 40-0156	Spring	Ressort	Feder	Resorte
	01 40-0157	Thrust Washer	Rondelle de butée	Druckscheibe	Anillo de empuje
	01 40-0158	Thrust Washer	Rondelle de butée	Druckscheibe	Anillo de empuje
	05 40-0483	Stud Nut	Écrou	Mutter	Tuerca
A65T/R	03 40-3226	Stud Nut	Écrou	Mutter	Tuerca
	09 67-0283	Cylinder Head Bolt	Boulon	Schraube	Tornillo
A65T/R	04 68-0066	Manifold Stud (lower)	Goujon	Stehbolzen	Esparago
A65T/R	04 68-0067	Manifold Stud (upper)	Goujon	Stehbolzen	Esparago
	85 68-0069	Cylinder Head	Culasse	Zylinderkopf	Culata
	09 68-0079	Head Stud (short)	Goujon	Stehbolzen	Esparago
	10 68-0081	Head Stud (long)	Goujon	Stehbolzen	Esparago
	03 68-0087	Rocker Box Stud (front and rear)	Goujon	Stehbolzen	Esparago
	06 68-0137	Domed Nut	Écrou borgne	Hutmutter	Tuerca abovedada
	04 68-0138	Rocker Box Stud (long)	Goujon	Stehbolzen	Esparago
	42 68-0139	Rocker Box Cover	Boltier des culbuteurs	Kipphebelkasten	Carter de los brazos oscilantes
	03 68-0143	Rocker Box Stud (short)	Goujon	Stehbolzen	Esparago
	07 68-0144	Joint Washer	Joint	Dichtung	Empaquetadura
	37 68-0147	Inlet Rocker (left-hand)	Culbuteur-admission	Einlasskippebel	Brazo oscilantes admisión
	37 68-0149	Inlet Rocker (right-hand)	Culbuteur-admission	Einlasskippebel	Brazo oscilantes admisión
	37 68-0151	Exhaust Rocket (left-hand)	Culbuteur-échappement	Auslasskippebel	Brazo oscilantes escape
	37 68-0153	Exhaust Rocker (right-hand)	Culbuteur-échappement	Auslasskippebel	Brazo oscilantes escape
	11 68-0155	Screw	Vis	Schraube	Tornillo
	33 68-0192	Rocker Spindle	Arbre	Welle	Arbol
	10 68-0337	Bolt (front)	Boulon	Schraube	Tornillo
	10 68-0338	Bolt (rear)	Boulon	Schraube	Tornillo
	17 68-0345	Oil Feed Pipe	Tuyauterie d'alimentation	Ölzufuhrleitung	Tubo de alimentación
	17 68-0345	Oil Feed Pipe	Tuyauterie d'alimentation d'huile	Ölzufuhrleitung	Tubo de alimentación de aceite
	06 68-8321	Oil Pipe Connection	Connexion	Verbinder	Conector
	10 76-0308	Oil Pipe Adaptor	Pièce ajustement	Anschlussrohr	Tubo de ajuste
	01 76-0378	Fibre Washer	Rondelle	Scheibe	Arandela
	18 68-0602	Oil Feed Pipe	Tuyauterie d'alimentation d'huile	Ölzufuhrleitung	Tubo de alimentación de aceite

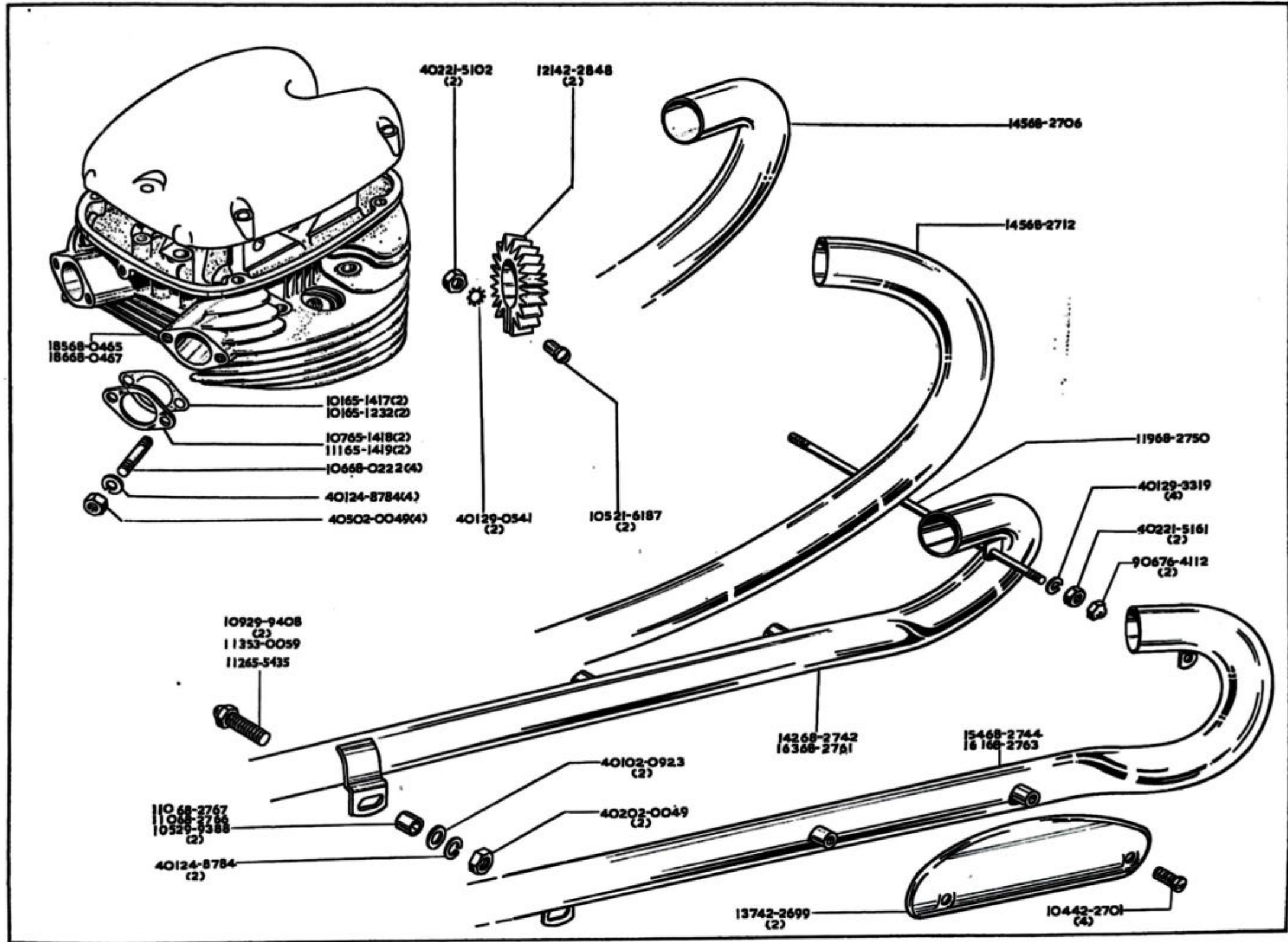

EXHAUST PIPE, TUYAU D'ÉCHAPPEMENT, AUSPUFFROHR, TUBO DE ESCAPE

Model Modèle Typen Modelos	Spares No. No. de pièce Ersatzteil-Nr. No. de repuesto	Description	Designation	Beschreibung	Descripción
A65S/H, A50C ...	02 02-0049	Nut	Écrou	Mutter	Tuerca
A65S/H, A50C ...	01 02-0923	Washer	Rondelle	Scheibe	Arandela
A65S/H, A50C ...	02 21-5102	Nut	Écrou	Mutter	Tuerca
A65S/H, A50C ...	01 21-5161	Nut	Écrou	Mutter	Tuerca
A65S/H, A50C ...	05 21-6187	Screw	Vis	Schraube	Tornillo
A65S/H, A50C ...	01 24-8784	Lockwasher	Rondelle frein	Sicherung	Freno
A65S/H, A50C ...	01 29-0541	Lockwasher	Rondelle frein	Sicherung	Freno
A65S/H, A50C ...	01 29-3319	Lockwasher	Rondelle frein	Sicherung	Freno
A65S/H, A50C ...	05 29-9388	Spacer	Tube entretoise	Distanzrohr	Tubo espaciador
A65S/H, A50C ...	09 29-9408	Bolt	Boulon	Schraube	Tornillo
A65S/H, A50C ...	37 42-2699	Cover Plate	Plaque couvercle	Abdeckplatte	Tapa del cojinete
A65S/H, A50C ...	04 42-2701	Screw	Vis	Schraube	Tornillo
A65S/H, A50C ...	21 42-2848	Collar	Bague d'arrêt	Stelling	Anillo móvil aprisionado
A65S/H, A50C Comp. ...	†13 53-0059	Bolt (right hand)	Boulon	Schraube	Tornillo
A50C ...	01 65-1232	Gasket	Joint	Dichtung	Empaquetadura
A65S/H, A50C Comp. ...	12 65-5435	Bolt (left-hand)	Boulon	Schraube	Tornillo
A65L/R, S/H, A50C ...	06 68-0222	Stud	Goujon	Stehbolzen	Esparago
A65L/R, S/H ...	85 68-0465	Cylinder Head	Culasse	Zylinderkopf	Culata
A50C ...	86 68-0467	Cylinder Head	Culasse	Zylinderkopf	Culata
A65L/R, S/H ...	01 65-1417	Gasket	Joint	Dichtung	Empaquetadura
A65L/R, S/H ...	07 65-1418	Gasket	Joint	Dichtung	Empaquetadura
A50C ...	11 65-1419	Gasket	Joint	Dichtung	Empaquetadura
A65T/R, L/R, A50C ...	45 68-2706	Exhaust Pipe (left-hand)	Tuyau d'échappement	Auspuffrohr	Tubo de escape
A65T/R, L/R, A50C ...	45 68-2712	Exhaust Pipe (right-hand)	Tuyau d'échappement	Auspuffrohr	Tubo de escape
A65S/H, A50C ...	42 68-2742	Exhaust Pipe (left-hand)	Tuyau d'échappement	Auspuffrohr	Tubo de escape
A65S/H, A50C ...	54 68-2744	Exhaust Pipe (right-hand)	Tuyau d'échappement	Auspuffrohr	Tubo de escape
A65S/H, A50C ...	19 68-2750	Tie Rod	Goujon	Stehbolzen	Esparago
A65S/H, A50C Comp. ...	†63 68-2761	Exhaust Pipe (left-hand)	Tuyau d'échappement	Auspuffrohr	Tubo de escape
A65S/H, A50C Comp. ...	†61 68-2763	Exhaust Pipe (right-hand)	Tuyau d'échappement	Auspuffrohr	Tubo de escape
A65S/H, A50C Comp. ...	†10 68-2766	Distance Piece (left-hand)	Entretoise	Distanzrohr	Distanciador
A65S/H, A50C Comp. ...	†10 68-2767	Distance Piece (right-hand)	Entretoise	Distanzrohr	Distanciador
A65S/H, A50C ...	06 76-4112	Domed Nut	Écrou borgne	Hutmutter	Tuerca abovedada
		†1965 models.	†1965 modèles.	†Typen 1965.	†1965 modelos.

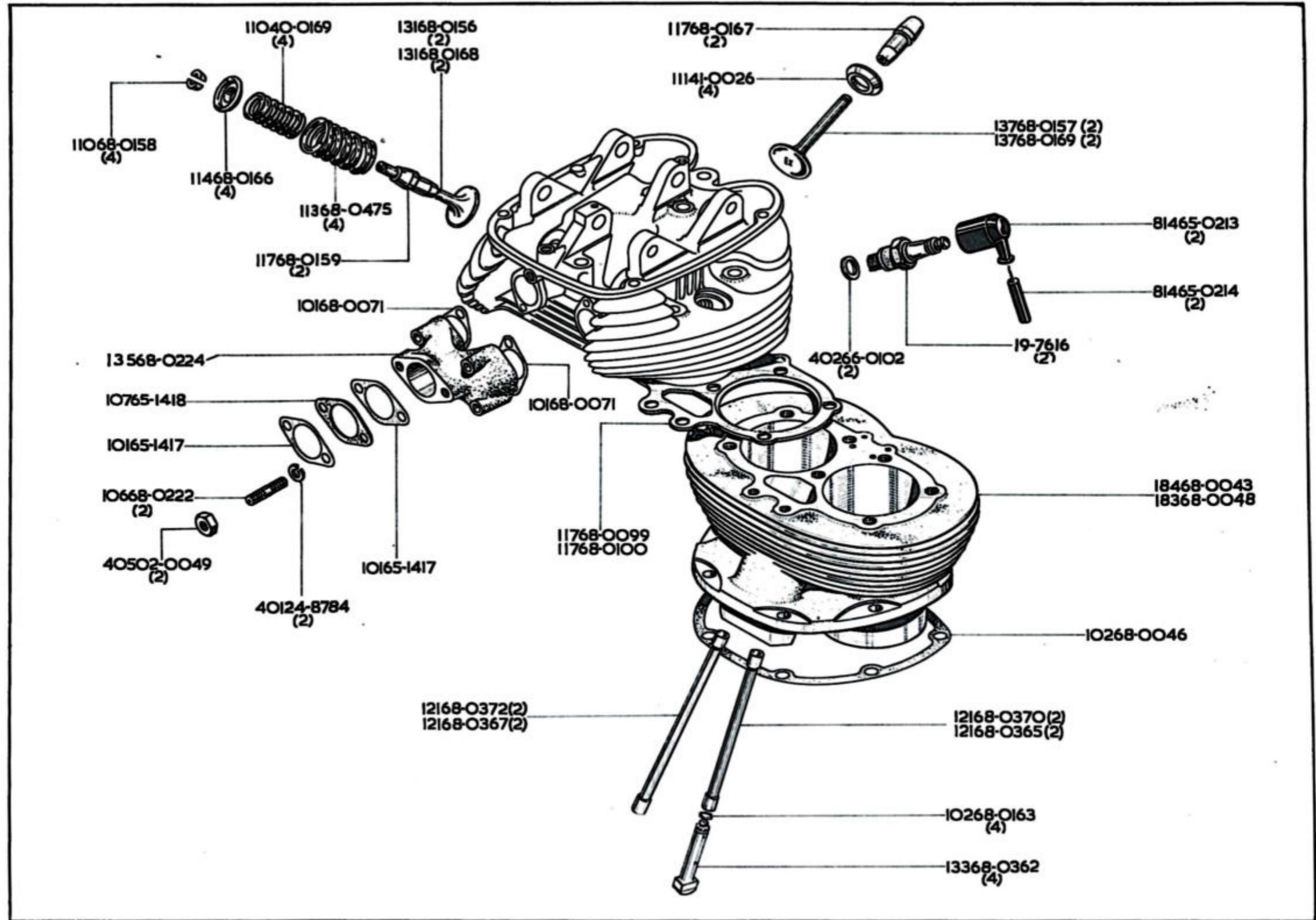

CYLINDER, CYLINDRE, ZYLINDER, CILINDRO

Model Modèle Typen Modelos	Spares No. No. de pièce Ersatzteil-Nr. No. de repuest	Description	Designation	Beschreibung	Descripcion
A65T/R	05 02-0049	Nut	Écrou	Mutter	Tuerca
	19-7616	Spark Plug	Bougie d'allumage	Zündkerze	Bujía
A65T/R	01 24-8784	Lockwasher	Rondelle frein	Sicherung	Freno
	10 40-0169	Inner Valve Spring	Ressort	Feder	Resorte
	11 41-0026	Spring Cup	Siège de ressort	Hülse	Copa
	14 65-0213	Spark Plug Cover	Couvercle	Schuttkappe	Tapa
	14 65-0214	Suppressor	Dispositif antiparasite	Wellensauge	Supresor
A65T/R	01 65-1417	Joint Washer	Joint	Dichtung	Empaquetadura
A65T/R	07 65-1418	Joint Washer	Joint	Dichtung	Empaquetadura
	02 66-0102	Spark Plug Washer	Rondelle	Scheibe	Arandela
A65T/R, L/R, S/H ...	84 68-0043	Cylinder Barrel	Cylindre	Zylinder	Cilindro
	02 68-0046	Washer	Rondelle	Scheibe	Arandela
A50C	83 68-0048	Cylinder Barrel	Cylindre	Zylinder	Cilindro
A65T/R	01 68-0071	Manifold Gasket	Joint	Dichtung	Empaquetadura
A65T/R, L/R, S/H ...	17 68-0099	Gasket	Joint	Dichtung	Empaquetadura
A50C	17 68-0100	Gasket	Joint	Dichtung	Empaquetadura
A65T/R, L/R, S/H ...	31 68-0156	Inlet Valve	Soupape d'admission	Einlassventil	Valvula de admisión
A65T/R, L/R, S/H ...	37 68-0157	Exhaust Valve	Soupape d'échappement	Auslassventil	Valvula de escape
	10 68-0158	Collet	Collet	Keil	Refuerzo del cilindro
	17 68-0159	Inlet Valve Guide	Guide de soupape	Ventilführung	Guia de valvula
	02 68-0163	Circlip	Circlip	Sprengring	Freno
	14 68-0166	Collar	Bague d'arrêt	Stellring	Anillo móvil aprisionado
	17 68-0167	Exhaust Valve Guide	Guide de soupape	Ventilführung	Guia de valvula
A50C	31 68-0168	Inlet Valve	Soupape d'admission	Einlassventil	Valvula de admisión
A50C	37 68-0169	Exhaust Valve	Soupape d'échappement	Auslassventil	Valvula de escape
A65T/R	06 68-0222	Stud	Goujon	Stehbolzen	Esparago
A65T/R	35 68-0224	Inlet Manifold	Collecteur	Verbindungsstück	Cabezal de union
	33 68-0362	Tappet	Poussoir	Stößel	Botador de valvula
A50C	21 68-0365	Inlet Push Rod	Tige de culbuteur	Schubstangerohr	Tubo de la varilla de empuje
A50C	21 68-0367	Exhaust Push Rod	Tige de culbuteur	Schubstangerohr	Tubo de la varilla de empuje
A65T/R, L/R, S/H ...	21 68-0370	Inlet Push Rod	Tige de culbuteur	Schubstangerohr	Tubo de la varilla de empuje
A65T/R, L/R, S/H ...	21 68-0372	Exhaust Push Rod	Tige de culbuteur	Schubstangerohr	Tubo de la varilla de empuje
	13 68-0475	Outer Valve Spring	Ressort	Feder	Resorte

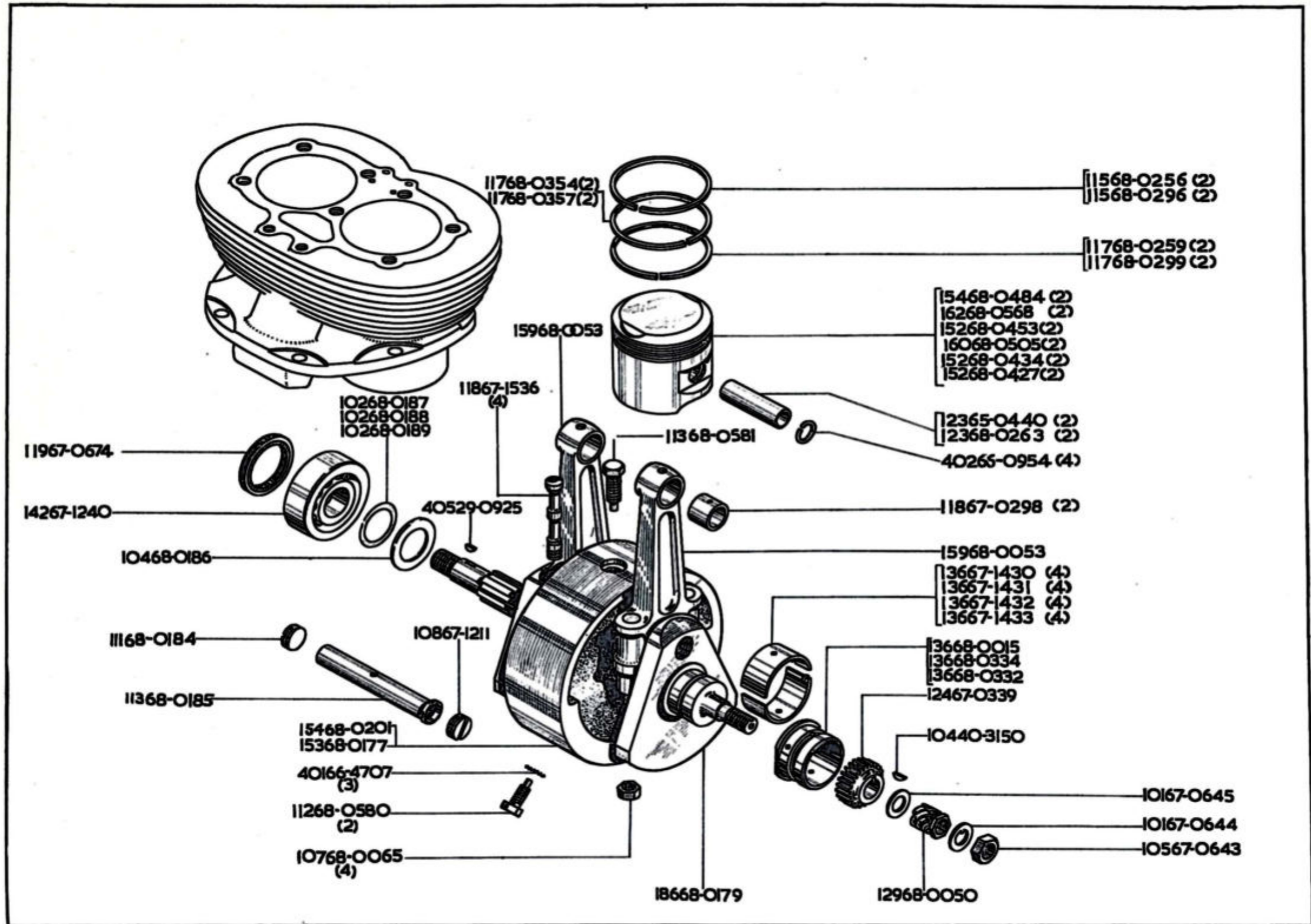

CRANKSHAFT, VILEBREQUIN, KURBELWELLE, CIGUÑAL

Model Modèle Typen Modelos	Spares No. No. de pièce Erstteil-Nr. No. de repuesto	Description	Designation	Beschreibung	Descripción
A65L/R, T/R, A50 ROAD MODEL	05 29-0925	Woodruff Key	Clavette disque	Rundkeil	Chaveta Woodruff
A65L/R, T/R, S/H ...	04 40-3150	Woodruff Key	Clavette disque	Rundkeil	Chaveta Woodruff
	23 65-0440	Gudgeon Pin	Axe de piston	Kobenbolzen	Bulón de embolo
	02 66-0954	Circlip	Circlip	Sprengring	Freno
	01 66-4707	Lockwasher	Rondelle frein	Sicherung	Freno
	18 67-0298	Bush	Douille	Büchse	Casquillo
	24 67-0339	Pinion	Pignon	Zahnrad	Piñón
	05 67-0643	Nut	Écrou	Mutter	Tuerca
	01 67-0644	Lockwasher	Rondelle frein	Sicherung	Freno
	01 67-0645	Washer	Rondelle	Scheibe	Arandela
	19 67-0674	Oil Seal	Joint d'huile	Dichtring	Reten de aceite
	42 67-1240	Bearing	Roulement	Lager	Rolamiento
	36 67-1430	Shell (standard)	Coquille de palier	Lager Schale	Chumacera
	36 67-1431	Shell (.010 in.)	Coquille de palier (.254 mm.)	Lager Schale (.254 mm.)	Chumacera (.254 mm.)
	36 67-1432	Shell (—,020 in.)	Coquille de palier (.508 mm.)	Lager Schale (.508 mm.)	Chumacera (.508 mm.)
	36 67-1433	Shell (—,030 in.)	Coquille de palier (.762 mm.)	Lager Schale (.762 mm.)	Chumacera (.762 mm.)
	18 67-1536	Bolt	Boulon	Schraube	Tornillo
	36 68-0015	Bush (standard)	Douille	Büchse	Casquillo
	29 68-0050	Pump Gear	Pignon	Zahnrad	Piñón
	59 68-0053	Con. Rod	Bielle	Pleuelstange	Varilla de acoplamiento
	07 68-0065	Nut	Écrou	Mutter	Tuerca
A65L/R, T/R, S/H ...	53 68-0177	Flywheel	Volant	Schwungmasse	Volante
	86 68-0179	Crankshaft	Vilebrequin	Kurbelwelle	Cigüñal
	11 68-0184	Plug	Bouchon	Stopfen	Tapón
	13 68-0185	Oil Tube	Tuyau pour huile	Oleitung	Tubo para aceite
	04 68-0186	Retaining Cup	Tige	Stange	Varilla
	02 68-0187	Shim (.003 in.)	Rondelle d'épaisseur (.0762 mm.)	Ausgleichsscheibe (.0762 mm.)	Espesor (.0762 mm.)
	02 68-0188	Shim (.005 in.)	Rondelle d'épaisseur (.127 mm.)	Ausgleichsscheibe (.127 mm.)	Espesor (.127 mm.)
	02 68-0189	Shim (.010 in.)	Rondelle d'épaisseur (.254 mm.)	Ausgleichsscheibe (.254 mm.)	Espesor (.254 mm.)
A50 C ...	54 68-0201	Flywheel	Volant	Schwungmasse	Volante
A65L/R, T/R, S/H ...	15 68-0256	Comp. Ring	Segment	Verdichtungsring	Segmento
A65L/R, T/R, S/H ...	17 68-0259	Scraper Ring	Segment	Verdichtungsring	Segmento
A50 C ...	23 68-0263	Gudgeon Pin	Axe de piston	Kolbenbolzen	Bulón de embolo
A50 C ...	15 68-0296	Comp. Ring	Segment	Verdichtungsring	Segmento
A50 C ...	17 68-0299	Scraper Ring	Segment	Verdichtungsring	Segmento
	36 68-0332	Bush (—,020 in.)	Douille (.508 mm.)	Büchse (.508 mm.)	Casquillo (.508 mm.)
	36 68-0334	Bush (—,010 in.)	Douille (.254 mm.)	Büchse (.254 mm.)	Casquillo (.254 mm.)
A50 C ...	17 68-0354	Taper Ring	Segment	Verdichtungsring	Segmento
A65L/R, T/R, S/H ...	17 68-0357	Taper Ring	Segment	Verdichtungsring	Segmento
A65L/R, T/R, S/H ...	*52 68-0427	Piston (8 : 1)	Piston complet (8 : 1)	Kolben komplett (8 : 1)	Embolo completo (8 : 1)
A50 C ...	*52 68-0434	Piston (9 : 1)	Piston complet (9 : 1)	Kolben komplett (9 : 1)	Embolo completo (9 : 1)
A50 C ...	*52 68-0453	Piston (8.5 : 1)	Piston complet (8.5 : 1)	Kolben komplett (8.5 : 1)	Embolo completo (8.5 : 1)
A65L/R, T/R, S/H ...	*54 68-0484	Piston (9 : 1)	Piston complet (9 : 1)	Kolben komplett (9 : 1)	Embolo completo (9 : 1)
A50 C ...	*60 68-0505	Piston (10 : 1)	Piston complet (10 : 1)	Kolben komplett (10 : 1)	Embolo completo (10 : 1)
A65L/R, T/R, S/H ...	*62 68-0568	Piston (11 : 1)	Piston complet (11 : 1)	Kolben komplett (11 : 1)	Embolo completo (11 : 1)
	12 68-0580	Flywheel Bolt	Boulon	Schraube	Tornillo
	13 68-0581	Flywheel Bolt	Boulon	Schraube	Tornillo
A65L/R, T/R, S/H ...	92 68-0615	Crankshaft and Flywheel Assembly	Vilebrequin complet	Kurbelwelle komplett	Cigüñal completo
A50 C ...	92 68-0618	Crankshaft and Flywheel Assembly	Vilebrequin complet	Kurbelwelle komplett	Cigüñal completo
		*See page 4.	*Voyez page 4.	*Siche Seite 4.	*Vide pagina 4.

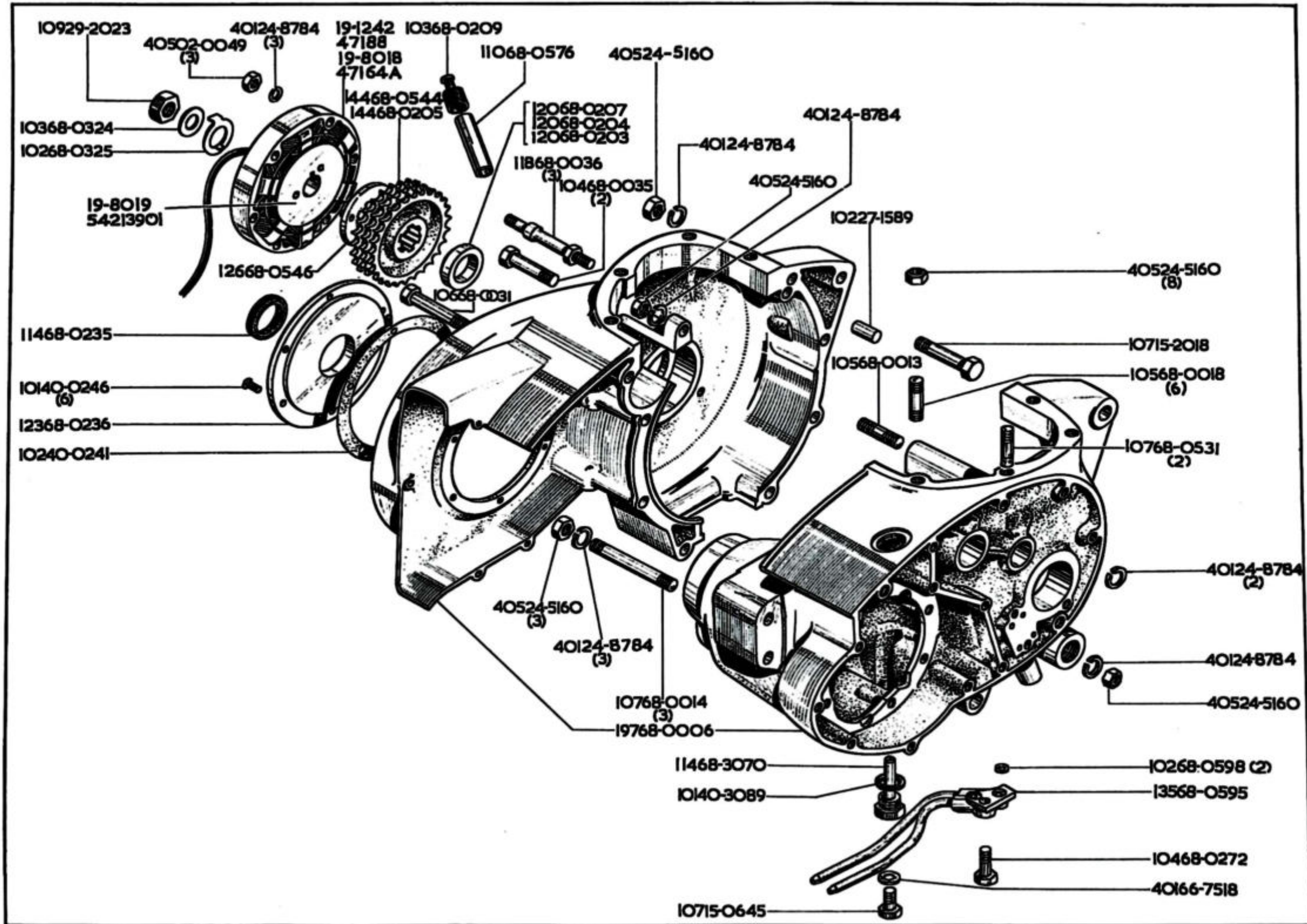

CRANKCASE, CARTER DE VILEBREQUIN, KURBELGEHÄUSE, CAJA DE CIGUËÑAL

Model Modèle Typen Modelos	Spares No. No. de pièce Ersatzteil Nr. No. de repuesto	Description	Designation	Beschreibung	Descripción
A65S/H, A50C ... A65T/R, A65L/R ...	05 02-0049	Nut	Écrou	Mutter	Tuerca
	07 15-0645	Bolt	Boulon	Schraube	Tornillo
	07 15-2018	Bolt (front)	Boulon	Schraube	Tornillo
	19-1242	Stator Plate	Stator	Stator	Stator
	19-8018	Stator Plate	Stator	Stator	Stator
	19-8019	Rotor	Rotor	Rotor	Rotor
	05 24-5160	Nut	Écrou	Mutter	Tuerca
	01 24-8784	Lockwasher	Rondelle frein	Sicherung	Freno
	02 27-1589	Dowel	Goujon	Passtift	Pasador
	09 29-2023	Rotor Nut	Écrou	Mutter	Tuerca
	02 40-0241	Gasket	Joint	Dichtung	Empaquetadura
	01 40-0246	Screw	Vis	Schraube	Tornillo
	01 40-3089	Fibre Washer	Rondelle	Scheibe	Arandela
	01 66-7518	Fibre Washer	Rondelle	Scheibe	Arandela
	97 68-0006	Crankcase complete	Carter de vilebrequin	Kurbelgehäuse	Caja de ciguëñal
	05 68-0013	Stud (top centre)	Goujon	Stehbolzen	Esparago
	07 68-0014	Stud (rear)	Goujon	Stehbolzen	Esparago
	05 68-0018	Stud	Goujon	Stehbolzen	Esparago
	06 68-0031	Bolt (front, bottom)	Boulon	Schraube	Tornillo
	04 68-0035	Bolt (front, centre)	Boulon	Schraube	Tornillo
	18 68-0036	Stator Stud	Goujon	Stehbolzen	Esparago
	20 68-0203	Distance Piece (.354—.358 in.).	Entretoise (8.9916—9.0932 mm.).	Distanzrohr (8.9916—9.0932 mm.).	Distanciadador (8.9916—9.0932 mm.).
	20 68-0204	Distance Piece (.373—.377 in.).	Entretoise (9.4742—9.5758 mm.).	Distanzrohr (9.4742—9.5758 mm.).	Distanciadador (9.4742—9.5758 mm.).
	44 68-0205	Engine Sprocket (28T)	Pignon (D-28)	Ritzel (Z-28)	Piñón (D-28)
	20 68-0207	Distance Piece (.392—.396 in.).	Entretoise (9.9568—10.0584 mm.).	Distanzrohr (9.9568—10.0584 mm.).	Distanciadador (9.9568—10.0584 mm.).
	03 68-0209	Oil Seal	Joint d'huile	Simmerring	Reten de aceite
	14 68-0235	Oil Seal	Joint d'huile	Simmerring	Reten de aceite
23 68-0236	Cover Plate	Plaque couvercle	Abdeckplatte	Tapa del cojinete	
04 68-0272	Union Bolt	Boulon	Schraube	Tornillo	
34 68-0275	Oil Pipe Union	Raccord d'alimentation d'huile.	Ölzufuhrverbindung	Union de la tuberia de alimentación de aceite.	
03 68-0324	Rotor Washer	Rondelle	Scheibe	Arandela	
02 68-0325	Rotor Lockwasher	Rondelle frein	Sicherung	Freno	
07 68-0531	Stud	Goujon	Stehbolzen	Esparago	
44 68-0544	Engine Sprocket (28T)	Pignon (D-28)	Ritzel (Z-28)	Piñón (D-28)	
A50C, A65S/H ... A50C, A65S/H ...	26 68-0546	Timing Disc	Disque de commande de l'avance.	Einstell-Lamelle	Disco de la regulación del avance.
	10 68-0576	Cable Guide	Guide	Führung	Guia
	34 68-0595	Oil Pipe Union	Raccord d'alimentation d'huile	Ölzufuhrverbindung	Union de la tuberia de alimentació
	01 68-0598	Joint Washer	Joint	Dichtung	Empaquetadura
	14 68-3070	Oil Level Plug	Bouchon	Zapfen	Tapon

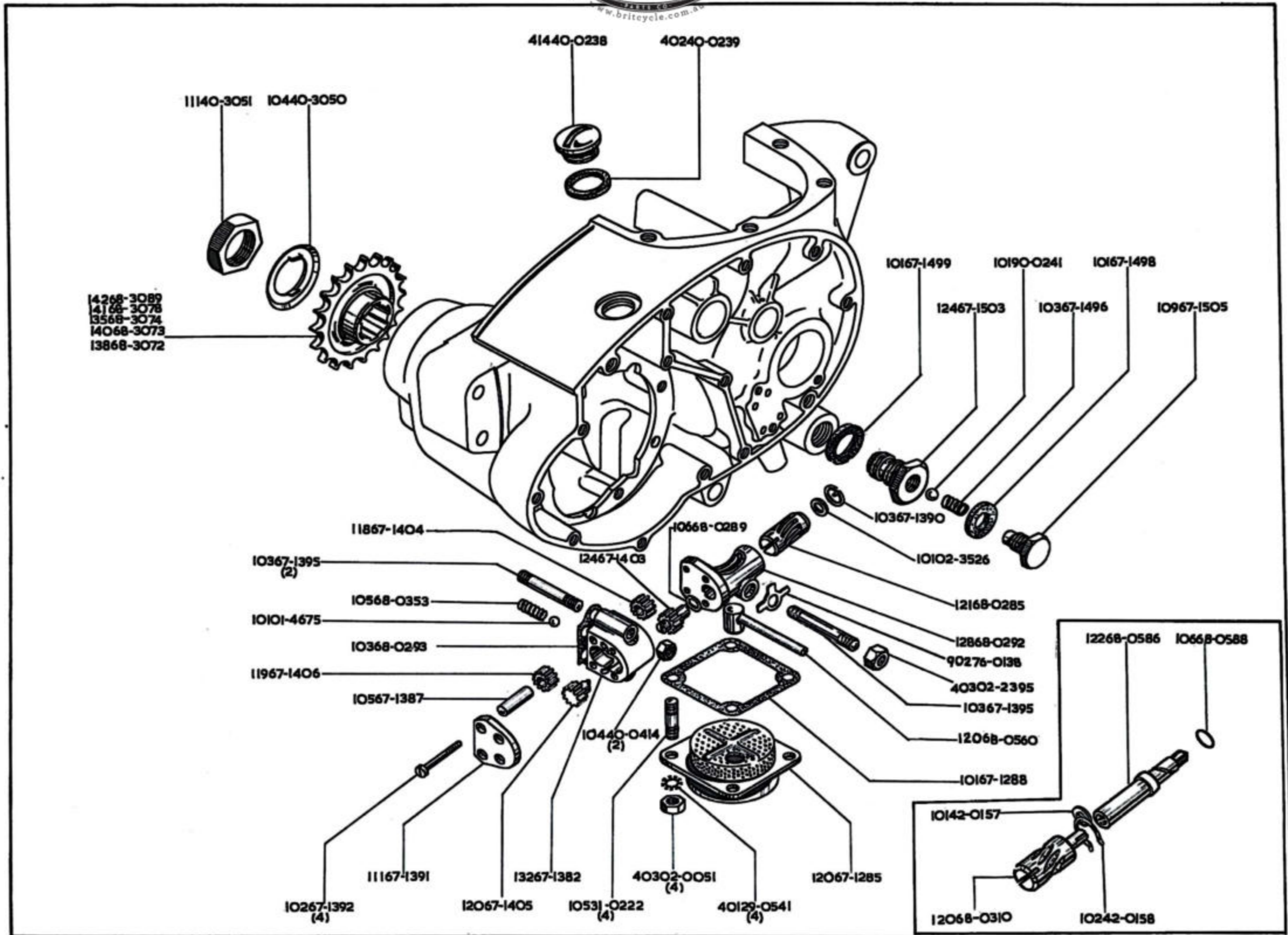

OIL PUMP, POMPE À HUILE, ÖLPUMPE, BOMBA DE ACEITE

Model Modèle Typen Modelos	Spare No. No. de pièce Ersatzteil-Nr. No. de repuesto	Description	Designation	Beschreibung	Descripción
	01 01-4675	Ball	Bille	Kugel	Bola
	03 02-0051	Cover Nut	Écrou	Mutter	Tuerca
	03 02-2395	Nut	Écrou	Mutter	Tuerca
	01 02-3526	Spindle Washer	Rondelle	Scheibe	Arandela
	01 29-0541	Cover Washer	Rondelle	Scheibe	Arandela
	05 31-0222	Cover Stud	Goujon	Stehbolzen	Esparago
	14 40-0238	Filler Plug	Bouchon de remplissage	Verschlusskappe	Tapa
	02 40-0239	Fibre Washer	Rondelle	Scheibe	Arandela
	04 40-0414	Nut	Écrou	Mutter	Tuerca
	04 40-3050	Lockwasher	Rondelle frein	Sicherung	Freno
	11 40-3051	Sprocket Nut	Écrou	Mutter	Tuerca
	01 42-0157	Washer	Rondelle	Scheibe	Arandela
	02 42-0158	Circlip	Circlip	Sprengring	Freno
	20 67-1285	Scavenge Cover	Couvercle	Schutzkappe	Tapa
	01 67-1288	Cover Gasket	Joint	Dichtung	Empaquetadura
	32 67-1382	Oil Pump Body	Corps de pompe à huile	Ölpumpegehäuse	Cuerpo de la bomba de aceite
	05 67-1387	Driven Gear Spindle	Arbre	Welle	Arbol
	03 67-1390	Spring Ring	Arrêtoir	Sicherung	Freno
	11 67-1391	Pump End Plate	Chapeau	Abschlusskappe	Tapa cerradora
	02 67-1392	End Plate Screw	Vis	Schraube	Tornillo
	03 67-1395	Pump Fixing Screw	Vis	Schraube	Tornillo
	24 67-1403	Feed Gear (driver)	Engrenage d'alimentation entraîneur.	Radantrieb	Engranaje de alimentación
	18 67-1404	Feed Gear (driven)	Engrenage d'alimentation	Zufuhrzahnrad	Engranaje de alimentación
	20 67-1405	Scavenge Gear (driver)	Engrana de retour d'huile	Spülzahnrad	Engranaje de barrido
	19 67-1406	Scavenge Gear (driven)	Engrana de retour d'huile	Spülzahnrad	Engranaje de barrido
	03 67-1496	Valve Spring	Ressort	Feder	Resorte
	01 67-1498	Fibre Washer	Rondelle	Scheibe	Arandela
	01 67-1499	Fibre Washer	Rondelle	Scheibe	Arandela
	24 67-1503	Valve Body	Corps	Gehäuse	Caja de la bomba
	09 67-1505	Body Plug	Bouchon	Stopfen	Tapon
	21 68-0285	Driving Spindle	Arbre	Welle	Arbol
	06 68-0289	"O" Ring	Bague "O"	"O" Ring	Anillo "O"
	28 68-0292	Spindle Housing	Logement boîtier	Gehäuse	Envoltura del eje
	03 68-0293	Joint Washer	Joint	Dichtung	Empaquetadura
	20 68-0310	Driving Spindle	Arbre	Welle	Arbol
	05 68-0353	Spring	Resort	Feder	Resorte
	20 68-0560	Scavenge Pipe	Tuyaux à huile	Ölrohr	Tubo de aceite
A65T/R, L/R, A50C	...	Drive Pin	Goupille primaire pour compte tour.	Antriebsstift für Drehzahlmesser.	Clavija conductor velocimetro.
A65T/R, L/R, A50C	...	"O" Ring	Bague "O"	"O" Ring	Anillo "O"
A65, A50	...	*38 68-3072	Pignon à chaîne (D-17)	Ritzel (Z-17)	Piñón (D-17)
A65	...	40 68-3073	Pignon à chaîne (D-20)	Ritzel (Z-20)	Piñón (D-20)
A50	...	†40 68-3074	Pignon à chaîne (D-16)	Ritzel (Z-26)	Piñón (D-16)
A65L/R	...	41 68-3078	Pignon à chaîne (D-19)	Ritzel (D-19)	Piñón (D-19)
A50C, S/H	...	42 68-3089	Pignon à chaîne (D-21)	Ritzel (Z-21)	Piñón (D-21)
	02 76-0138	Lockwasher	Rondelle frein	Sicherung	Freno
	01 90-0241	Ball	Bille	Kugel	Boal
		*A65 Side car, A50 Solo.	*A65 Sidecar, A50 Solo.	*A65 Beiwagen, A50 Solo.	*A65 Side-car, A50 Solo.
		†A50 Solo.	†A50 Solo.	†A50 Solo.	†A50 Solo.

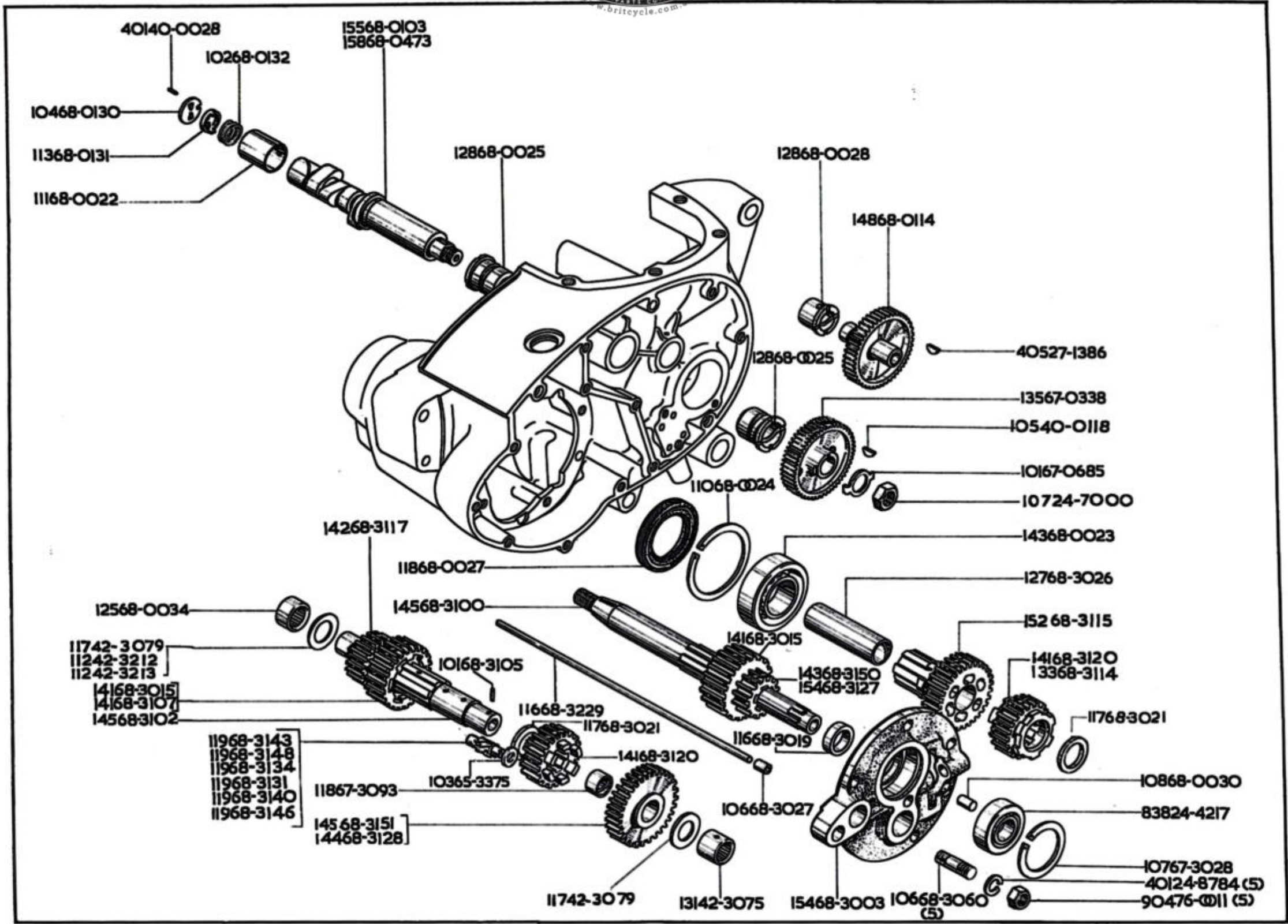

GEARBOX AND FITTINGS, BOITE DE VITESSES, GETRIEBE, CAJA DE VELOCIDADES

Model Modèle Typen Modelos	Spare No. No. de pièce Ersatzteil-Nr. No. de repuesto	Description	Designation	Beschreibung	Descripción
	38 24-4217	Bearing	Roulement	Lager	Rolamiento
	07 24-7000	Camshaft Nut	Écrou	Mutter	Tuerca
	01 24-8784	Lockwasher	Rondelle frein	Sicherung	Freno
	05 27-1386	Idler Pinion Key	Clavette	Rundkeil	Chaveta Woodruff
	01 40-0028	Breather Peg	Ergo	Stift	Esparago
	05 40-0118	Camshaft Key	Clavette	Rundkeil	Chaveta Woodruff
	31 42-3075	Needle Bearing	Roulement à aiguilles	Nadellager	Cojinete de agujas
	17 42-3079	Thrust Washer	Rondelle de butée	Druckscheibe	Anillo de empuje
	12 42-3212	Thrust Washer	Rondelle de butée	Druckscheibe	Anillo de empuje
	12 42-3213	Thrust Washer	Rondelle de butée	Druckscheibe	Anillo de empuje
	35 67-0338	Camshaft Pinion	Pignon de l'arbre de cames	Nockenwelle-Ritzel	Piñón del árbol de levas
	01 67-0685	Lockwasher	Rondelle frein	Sicherung	Freno
	07 67-3028	Circlip	Arrêtoir	Sprengring	Freno
	18 67-3093	Gear Bush	Douille	Büchse	Casquillo
	11 68-0022	Camshaft Bush	Douille	Büchse	Casquillo
	43 68-0023	Bearing (drive-side)	Roulement (gauche)	Lager (links)	Rolamiento (izquierdo)
	10 68-0024	Circlip	Arrêtoir	Sprengring	Freno
	28 68-0025	Camshaft Bush	Douille	Büchse	Casquillo
	18 68-0027	Oil Seal	Joint d'huile	Dichtring	Reten de aceite
	28 68-0028	Bush	Douille	Büchse	Casquillo
	08 68-0030	Dowel	Goujon	Passtift	Pasador
	25 68-0034	Needle Bearing	Roulement à aiguilles	Nadellager	Cojinete de agujas
A50C ROAD MODEL ...	55 68-0103	Camshaft	Arbre de cames	Nockenwelle	Árbol de levas
	48 68-0114	Idler Pinion	Pignon	Ritzel	Piñón
	04 68-0130	Breather Disc	Disc d'aspiration	Ventilkappe	Disco del respirador
	13 68-0131	Rotary Valve	Valve de rotation	Drehventil	Válvula rotatorio
	02 68-0132	Valve Spring	Ressort	Feder	Resorte
	58 68-0473	Camshaft	Arbre de cames	Nockenwelle	Árbol de levas
	54 68-3003	Bearing Plate	Plaque couvercle	Abdeckplatte	Tapa del cojinete
	*†41 68-3015	Gear (26T)	Pignon (D-26)	Ritzel (Z-26)	Piñón (D-26)
	16 68-3019	Spacing Washer	Rondelle	Scheibe	Arandela
	17 68-3021	Spacing Washer	Rondelle	Scheibe	Arandela
	27 68-3026	Top Gear Bush	Douille	Büchse	Casquillo
	06 68-3027	Mainshaft Bush	Douille	Büchse	Casquillo

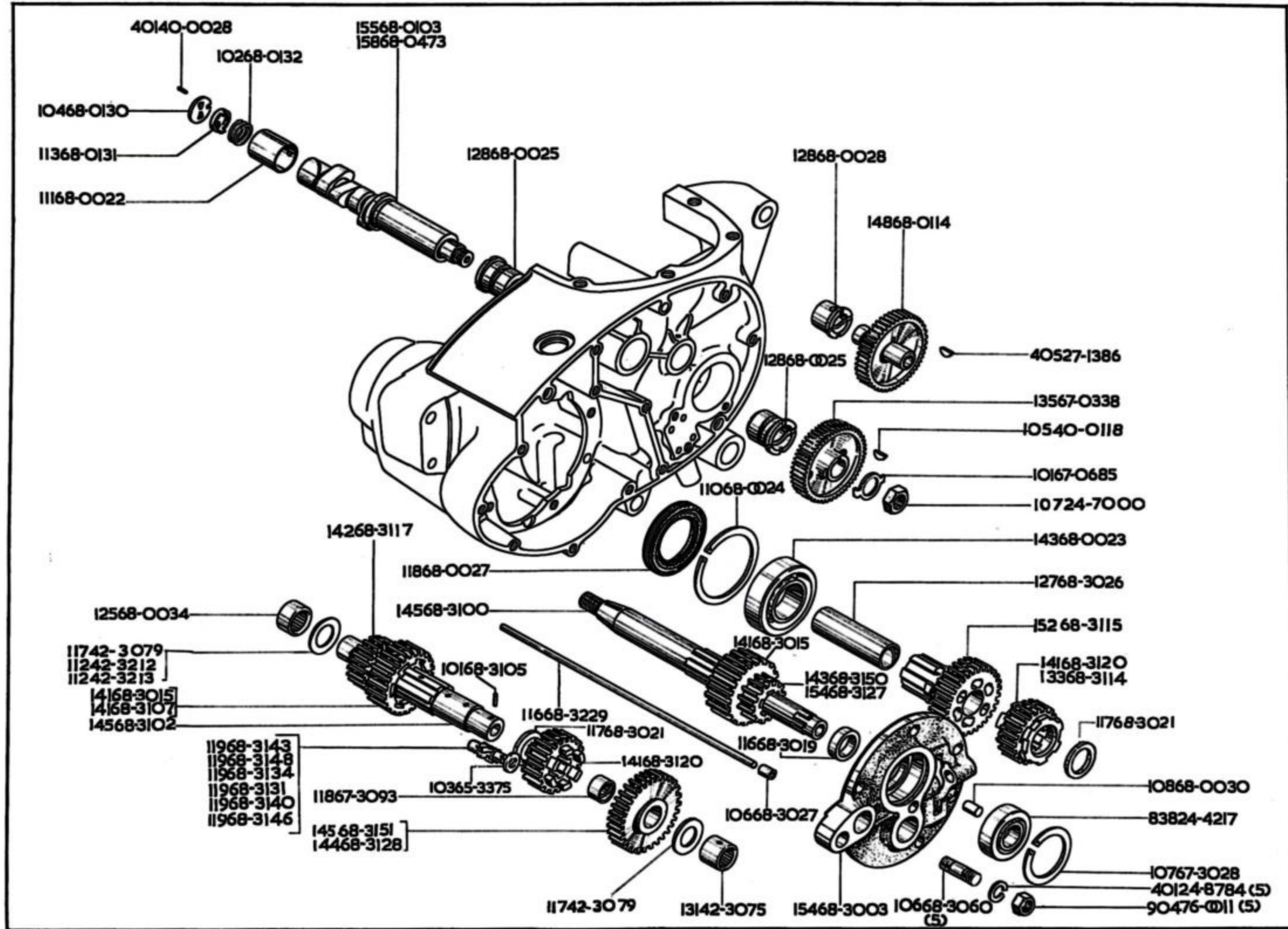

GEARBOX AND FITTINGS, BOITE DE VITESSES, GETRIEBE, CAJA DE VELOCIDADES

Model Modèle Typen Modelos	Spares No. No. de pièce Ersatzteil-Nr. No. de repuesto	Description	Designation	Beschreibung	Descripción
	06 68-3060	Stud	Goujon	Stehbolzen	Esparago
	45 68-3100	Mainshaft	Arbre primaire	Getriebewelle komplett	Arbol principal completo
	45 68-3102	Layshaft	Arbre de renvoi complet	Vorgelewelle komplett	Eje secundario completo
	01 68-3105	Peg	Ergo	Stift	Esparago
	*41 68-3107	Layshaft Gear (25T)	Pignon (D-25)	Ritzel (Z-25)	Piñón (D-25)
	*33 68-3114	Mainshaft Gear (23T)	Pignon (D-23)	Ritzel (Z-23)	Piñón (D-23)
	*†52 68-3115	Mainshaft Gear (23T)	Pignon (D-23)	Ritzel (Z-23)	Piñón (D-23)
	*†42 68-3117	Layshaft Gear (17T)	Pignon (D-17)	Ritzel (Z-17)	Piñón (D-17)
	*†41 68-3120	Mainshaft and Layshaft Gear (22T)	Pignon (D-22)	Ritzel (Z-22)	Piñón (D-22)
	*54 68-3127	Mainshaft Gear (16T)	Pignon (16)	Ritzel (Z-16)	Piñón (D-16)
	*44 68-3128	Layshaft Gear (24T)	Pignon (D-24)	Ritzel (Z-24)	Piñón (D-24)
A65T/R	19 68-3131	Speedo Driving Gear (7T)	Pignon (D-7)	Ritzel (Z-7)	Piñón (D-7)
A65T/R, L/R	19 68-3134	Speedo Driving Gear (7T)	Pignon (D-7)	Ritzel (Z-7)	Piñón (D-7)
A65L/R	19 68-3140	Speedo Driving Gear (8T)	Pignon (D-8)	Ritzel (Z-8)	Piñón (D-8)
A65S/H, A50C	19 68-3143	Speedo Driving Gear (7T)	Pignon (D-7)	Ritzel (Z-7)	Piñón (D-7)
A65T/R	19 68-3146	Speedo Driving Gear (8T)	Pignon (D-8)	Ritzel (Z-8)	Piñón (D-8)
A65T/R	19 68-3148	Speedo Driving Gear (6T)	Pignon (D-6)	Ritzel (Z-6)	Piñón (D-6)
	†43 68-3150	Mainshaft Gear (14T)	Pignon (D-14)	Ritzel (Z-14)	Piñón (D-14)
	†45 68-3151	Layshaft Gear (26T)	Pignon (D-26)	Ritzel (Z-26)	Piñón (D-26)
	16 68-3229	Clutch Push Rod	Tige d'embrayage	Kupplungsdruckstange	Varilla del embrague
	04 76-0011	Nut	Écrou	Mutter	Tuerca
		*Close ratio.	*Engrenage avec proportion basse.	*Getriebe mit Niedrigerer Übersetzung.	*Engranaje con bajo proporcio.
		†Standard ratio.	†Engrenage de talon.	†Standard-Getriebe.	†Engranaje de marca.

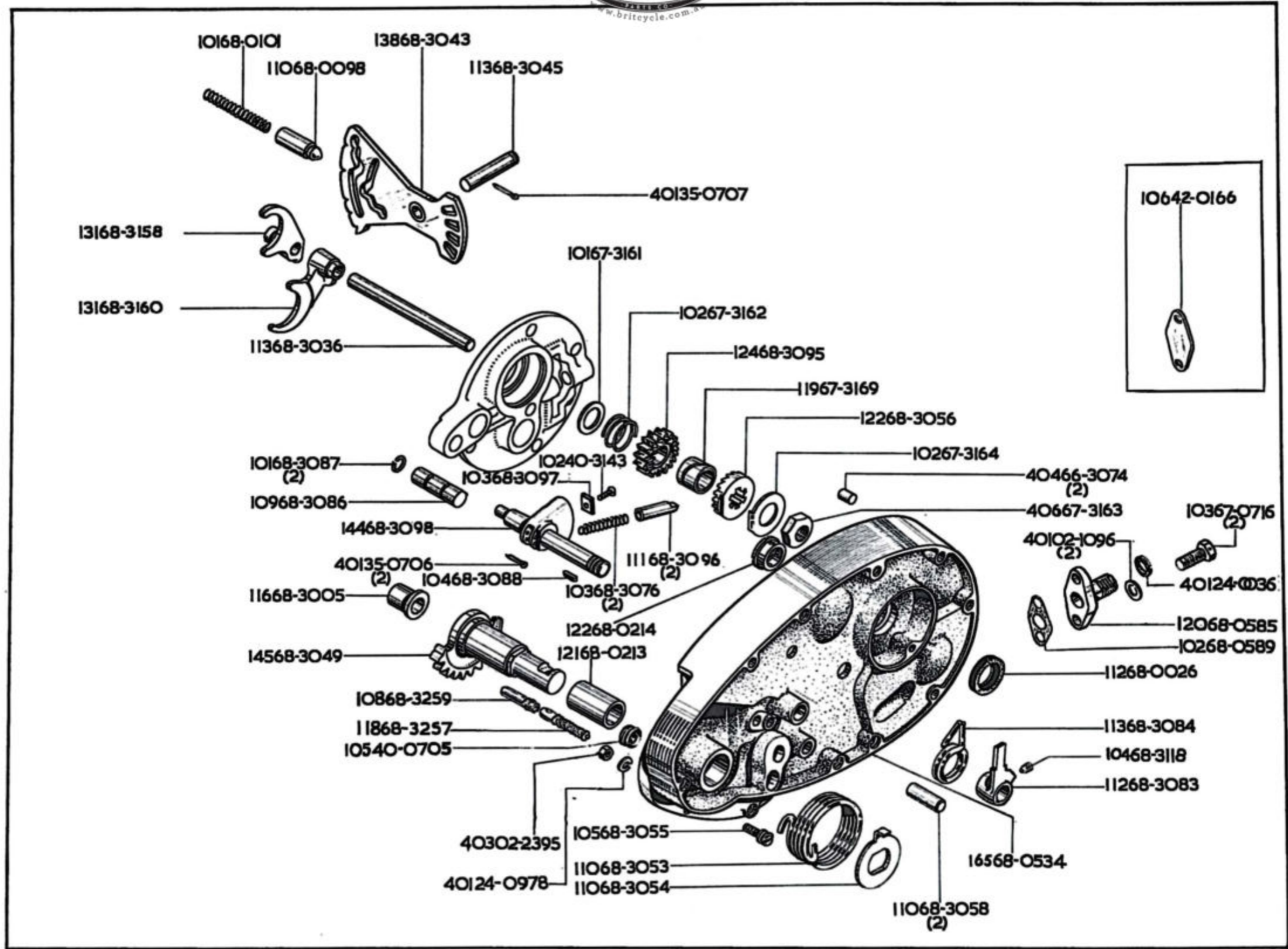

GEARCHANGE MECHANISM, MÉCANISME DE CHANGEMENT DE VITESSES, SCHALTUNG, CAMBIO

Model Modèle Typen Modelos	Spare No. No. de pièce Ersatzteil-Nr. No. de repuesto	Description	Designation	Beschreibung	Descripción
A65S/H	01 02-1096	Washer	Rondelle	Scheibe	Arandela
	03 02-2395	Nut	Écrou	Mutter	Tuerca
	01 24-0036	Fibre Washer	Rondelle	Scheibe	Arandela
	01 24-0978	Lockwasher	Rondelle frein	Sicherung	Freno
	01 35-0706	Split Pin	Goupille fendue	Splint	Chaveta hendida
	01 35-0707	Split Pin	Goupille fendue	Splint	Chaveta hendida
	05 40-0705	Grommet	Rondelle capuchon	Tülle	Manguera
	02 40-3143	Screw	Vis	Schraube	Tornillo
	06 42-0166	Cover Plate	Plaque couvercle	Abdeckplatte	Tapa del cojinete
	04 66-3074	Dowel	Goujon	Passtift	Pasador
	03 67-0716	Bolt	Boulon	Schraube	Tornillo
	01 67-3161	Thrust Washer	Rondelle de butée	Druckscheibe	Anillo de empuje
	02 67-3162	Spring	Ressort	Feder	Resorte
	06 67-3163	Nut	Écrou	Mutter	Tuerca
	02 67-3164	Lockwasher	Rondelle frein	Sicherung	Freno
	19 67-3169	Bush	Douille	Büchse	Casquillo
	12 68-0026	Oil Seal	Joint d'huile	Dichtring	Reten de aceite
	10 68-0098	Plunger	Plongeur	Plunger	Buzo
	01 68-0101	Spring	Ressort	Feder	Resorte
	21 68-0213	Bush	Douille	Büchse	Casquillo
	22 68-0214	Bush	Douille	Büchse	Casquillo
	65 68-0534	Cover	Couvercle interieur	Innere-Schutzkappe	Tapa interior
	20 68-0585	Nipple	Écrou de rayon	Nippel	Tuerca
	02 68-0589	Washer	Joint	Dichtung	Empaquetadura
	16 68-3005	Bush	Douille	Büchse	Casquillo
	13 68-3036	Spindle	Arbre	Welle	Arbol
	38 68-3043	Cam Plate	Plaque de came	Nockenplatte	Placa de leva
	13 68-3045	Pivot	Pivot	Tragzapfen	Axis
	45 68-3049	Kickstarter Spindle	Arbre du kick	Kickstarterwelle	Arbol del arrancador
	10 68-3053	Spring	Ressort	Feder	Resorte
	10 68-3054	Spring Plate	Plaque d'ancrage de ressort	Federplatte	Placa de resorte
	05 68-3055	Anchor Peg	Ergot	Sicherungsstift	Esparago
	22 68-3056	Ratchet	Pignon de kick	Kickstarterritzel	Piñón del arrancador
	10 68-3058	Anchor Peg	Ergot	Sicherungsstift	Esparago
	03 68-3076	Spring	Ressort	Feder	Resorte
	12 68-3083	Stop Plate	Plaque d'arrêt	Anschlag	Placa limitadora
	13 68-3084	Return Spring	Ressort	Feder	Resorte
	09 68-3086	Kickstart—stop	Butée de kick	Kickstarteranschlag	Depositivo de topo
	01 68-3087	Circlip	Arrêtoir	Sprengring	Freno
	04 68-3088	Lever Key	Clavette	Keil	Chaveta
24 68-3095	Pinion	Pignon de kick	Kickstarterritzel	Piñón del arrancador	
11 68-3096	Plunger	Plongeur	Plunger	Buzo	
03 68-3097	Retainer	Plaque arrêtoir	Haltescheibe	Placa retenadora	
44 68-3098	Quadrant	Secteur complet	Quadrant komplett	Sector completo	
04 68-3118	Grub Screw	Vis	Schraube	Tornillo	
31 68-3158	Selector Fork	Fourchette de selecteur	Schaltgabel	Horquilla de mando de caja de velocidades.	
31 68-3160	Selector Fork	Fourchette de selecteur	Schaltgabel	Horquilla de mando de caja de velocidades.	
18 68-3257	Connector	Connexion	Verbinder	Conector	
08 68-3259	Abutment	Goupille d'arrêt	Kabelanschlag	Boton retentor	

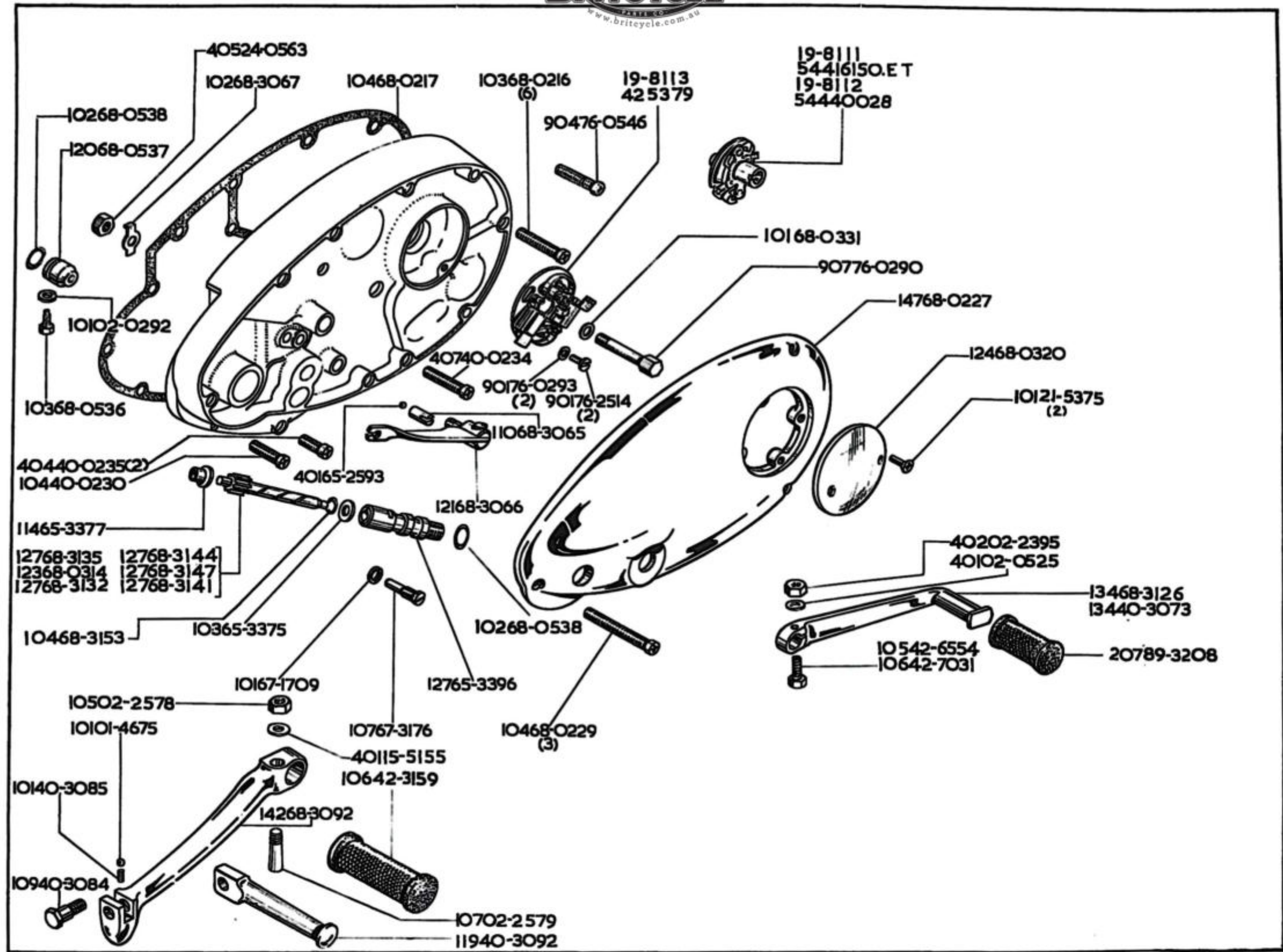

**FOOTSTART AND
FOOTCHANGE**

**KICKSTART ET
SELECTEUR AU PIED**

**KICKSTART UND
FUSSSCHALTUNG**

**ARRANCADOR Y
CAMBIO DE PIES**

Model Modèle Typen Modelos	Spares No. No. de pièce Ersatzteil-Nr. No. de repuesto	Description	Designation	Beschreibung	Descripción
	01 01-4675	Ball	Bille	Kugel	Bola
	01 02-0292	Fibre Washer	Rondelle fibre	Fiberscheibe	Arandela-fibra
A65S/H, A50C	01 02-0525	Washer	Rondelle	Scheibe	Arandela
A65S/H, A50C	02 02-2395	Nut	Écrou	Mutter	Tuerca
	05 02-2578	Cotter Nut	Écrou	Mutter	Tuerca
	07 02-2579	Crank Cotter	Clavette	Sicherungsstift	Chaveta
	01 15-5155	Washer	Rondelle	Scheibe	Arandela
A65S/H, A50C	19-8111	Advance Unit	Avance automatique	Fuehkraftregler	Avance automatico
A65T/R, L/R	19-8112	Advance Unit	Avance automatique	Fuehkraftregler	Avance automatico
	19-8113	Contact Breaker Unit	Contacts du rupteur complet	Unter Brecher komplett	Martillo del interruptor completo
	01 21-5357	Screw	Vis	Schraube	Tornillo
	05 24-0563	Nut	Écrou	Mutter	Tuerca
	04 40-0230	Screw (short)	Vis	Schraube	Tornillo
	07 40-0234	Screw (medium)	Vis	Schraube	Tornillo
	04 40-0235	Screw	Vis	Schraube	Tornillo
A65T/R, L/R	34 40-3073	Footchange Pedal	Levier de commande de changement de vitesse.	Schalthebel	Palanca de cambio
	09 40-3084	Bolt	Boulon	Schraube	Tornillo
	01 40-3085	Spring	Ressort	Feder	Resorte
	19 40-3092	Kickstarter Pedal	Pédale	Schwenkhebel	Pedal
	06 42-3159	Pedal Rubber	Tampon	Gummiauflage	Cojin de goma
	06 42-3159	Pedal Rubber	Tampon caoutchouc	Gummiauflage	Cojin de goma
A65T/R, L/R	05 42-6554	Bolt	Boulon	Schraube	Tornillo
A65S/H, A50C	06 42-7031	Bolt	Boulon	Schraube	Tornillo
	01 65-2593	Ball	Bille	Kugel	Bola
	03 65-3375	Thrust Washer	Rondelle de butée	Druckscheibe	Anillo de empuje
	14 65-3377	Bush	Douille	Büchse	Casquillo
	27 65-3396	Bush	Douille	Büchse	Casquillo
	01 67-1709	Fibre Washer	Rondelle fibre	Fiberscheibe	Arandela-fibra
	07 67-3176	Pin	Ergot	Stift	Esparago
	03 68-0216	Screw (long)	Vis	Schraube	Tornillo
	04 68-0217	Joint Washer	Joint	Dichtung	Empaquetadura
	47 68-0227	Outer Cover	Couvercle extérieur	Aussen Schutzkappe	Tapa exterior
	04 68-0229	Screw	Vis	Schraube	Tornillo

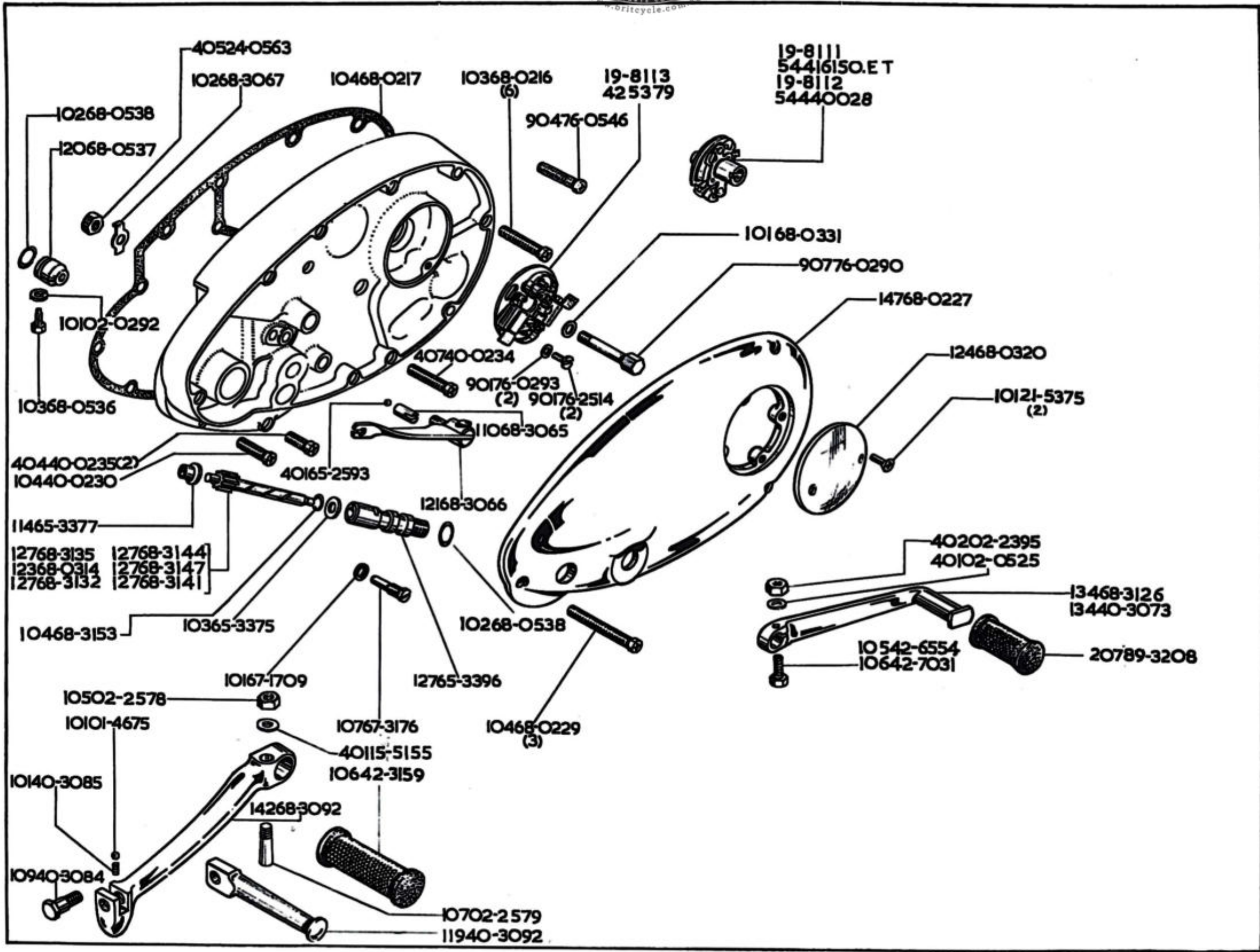

**FOOTSTART AND
FOOTCHANGE**

**KICKSTART ET
SELECTEUR AU PIED**

**KICKSTART UND
FUSSSCHALTUNG**

**ARRANCADOR Y
CAMBIO DE PIES**

Model Modèle Typen Modelos	Spares No. No. de pièce Ersatzteil-Nr. No. de repuesto	Description	Designation	Beschreibung	Descripción
	*23 68-0314	Gear (11T)	Pignon (D-11)	Ritzel (Z-11)	Piñón (D-11)
	24 68-0320	Inspection Cover	Couvercle d'inspection	Inspektionkappe	Tapa de visita
	01 68-0331	Washer	Rondelle	Scheibe	Arandela
	03 68-0536	Pin	Ergot	Stift	Esparago
	20 68-0537	Bush	Douille	Büchse	Casquillo
	02 68-0538	"O" Ring	Bague "O"	"O" Ring	Anillo "O"
	10 68-3065	Plunger	Plongeur	Plunger	Buzo
	21 68-3066	Clutch Lever	Levier	Hebel	Palanca
	02 68-3067	Lockwasher	Rondelle frein	Sicherung	Freno
	48 68-3092	Kickstarter Crank	Pédale de kick	Starthebel	Arrancador
S/H, A50C	34 68-3126	Footchange Pedal	Levier de vitesses	Schalthebel	Palanca del cambio
T/R	*27 68-3132	Gear (12T)	Pignon (D-12)	Ritzel (Z-12)	Piñón (D-12)
T/R, L/R	*27 68-3135	Gear (10T)	Pignon (D-10)	Ritzel (Z-10)	Piñón (D-10)
L/R	*27 68-3141	Gear (11T)	Pignon (D-11)	Ritzel (Z-11)	Piñón (D-11)
S/R, A50C	*27 68-3144	Gear (11T)	Pignon (D-11)	Ritzel (Z-11)	Piñón (D-11)
	*27 68-3147	Gear (12T)	Pignon (D-12)	Ritzel (Z-12)	Piñón (D-12)
	04 68-3153	"O" Ring	Bague "O"	"O" Ring	Anillo "O"
	07 76-0290	Bolt	Boulon	Schraube	Tornillo
	01 76-0293	Washer	Rondelle	Scheibe	Arandela
	04 76-0546	Screw	Vis	Schraube	Tornillo
	01 76-2514	Screw	Vis	Schraube	Tornillo
	07 89-3208	Pedal Rubber	Tampon caoutchouc	Gummiauflage	Cojin de goma
		*See page 4.	*Voyez page 4.	*Sehen Seite 4.	*Vida pagina 4.

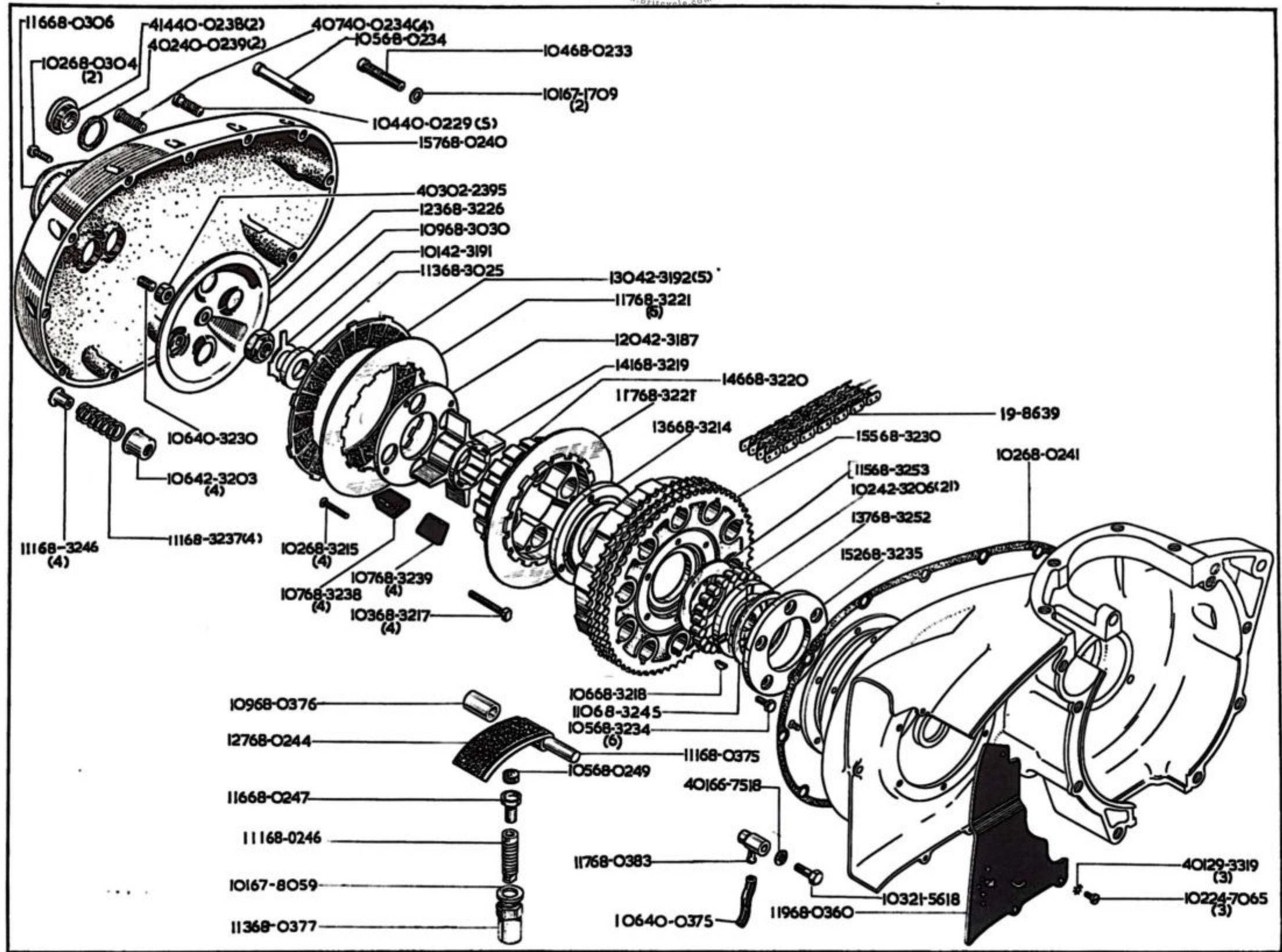

CLUTCH, EMBRAYAGE, KUPPLUNG, EMBRAGUE

Model Modèle Typen Modelos	Spare No. No. de pièce Ersatzteil-Nr. No. de repuesto	Description	Designation	Beschreibung	Descripción
	03 02-2395	Nut	Écrou	Mutter	Tuerca
	19-8639	Primary Chain	Chaîne primaire	Antriebskette	Cadena motrice
	03 21-5618	Bolt	Boulon	Schraube	Tornillo
	02 24-7065	Screw	Vis	Schraube	Tornillo
	01 29-3319	Lockwasher	Rondelle frein	Sicherung	Freno
	04 40-0229	Screw (short)	Vis	Schraube	Tornillo
	07 40-0234	Screw (long)	Vis	Schraube	Tornillo
	14 40-0238	Plug	Bouchon	Stopfen	Tapon
	02 40-0239	Fibre Washer	Rondelle-fibre	Fiberscheibe	Arandela fibre
	06 40-0375	Oil Pipe	Conduit ou canalisation d'huile	Schmierleitung	Conexión de engrase
	06 40-3230	Adjuster Screw	Vis de réglage	Einstellschraube	Tornillo de ajuste
	20 42-3187	Outer Plate	Plaque arrêtoir	Haltescheibe	Placa retenedora
	01 42-3191	Lockwasher	Rondelle frein	Sicherung	Freno
	30 42-3192	Driving Plate	Disque d'entraînement	Mitnehmerplatte	Placa de manda
	06 42-3203	Spring Cup	Siège de ressort	Hülse	Copa
	02 42-3206	Roller	Rouleau	Rolle	Rodillo
	01 66-7518	Fibre Washer	Rondelle-fibre	Fiberscheibe	Arandela fibre
	01 67-1709	Fibre Washer	Rondelle-fibre	Fiberscheibe	Arandela fibre
	01 67-8059	Fibre Washer	Rondelle-fibre	Fiberscheibe	Arandela fibre
	04 68-0233	Screw	Vis	Schraube	Tornillo
	07 68-0234	Screw	Vis	Schraube	Tornillo
	57 68-0240	Primary Cover	Couvercle primaire	Primarkappe	Tapa primario
	02 68-0241	Joint Washer	Joint	Dichtung	Empaquetadura
	27 68-0244	Chain Tensioner	Tendeur	Spannfeder	Tensor
	11 68-0246	Adjuster Screw	Vis de réglage	Einstellschraube	Tornillo de ajuste
	16 68-0247	Tensioner Peg	Ergot	Stift	Esparago
	05 68-0249	Peg Insert	Garniture	Bellé	Guarniciones
	02 68-0304	Screw	Vis	Schraube	Tornillo
	16 68-0306	Cover	Couvercle	Schutzkappe	Tapa
	19 68-0360	Cover Plate	Plaque couvercle	Abdeckplatte	Tapa del cojinete
	11 68-0375	Pivot Pin	Pivot	Zapfen	Eje
	09 68-0376	Spacer	Entretoise	Distanzrohr	Distanciador
	13 68-0377	Adjuster Nut	Écrou de réglage	Stellmutter	Tuerca de ajuste

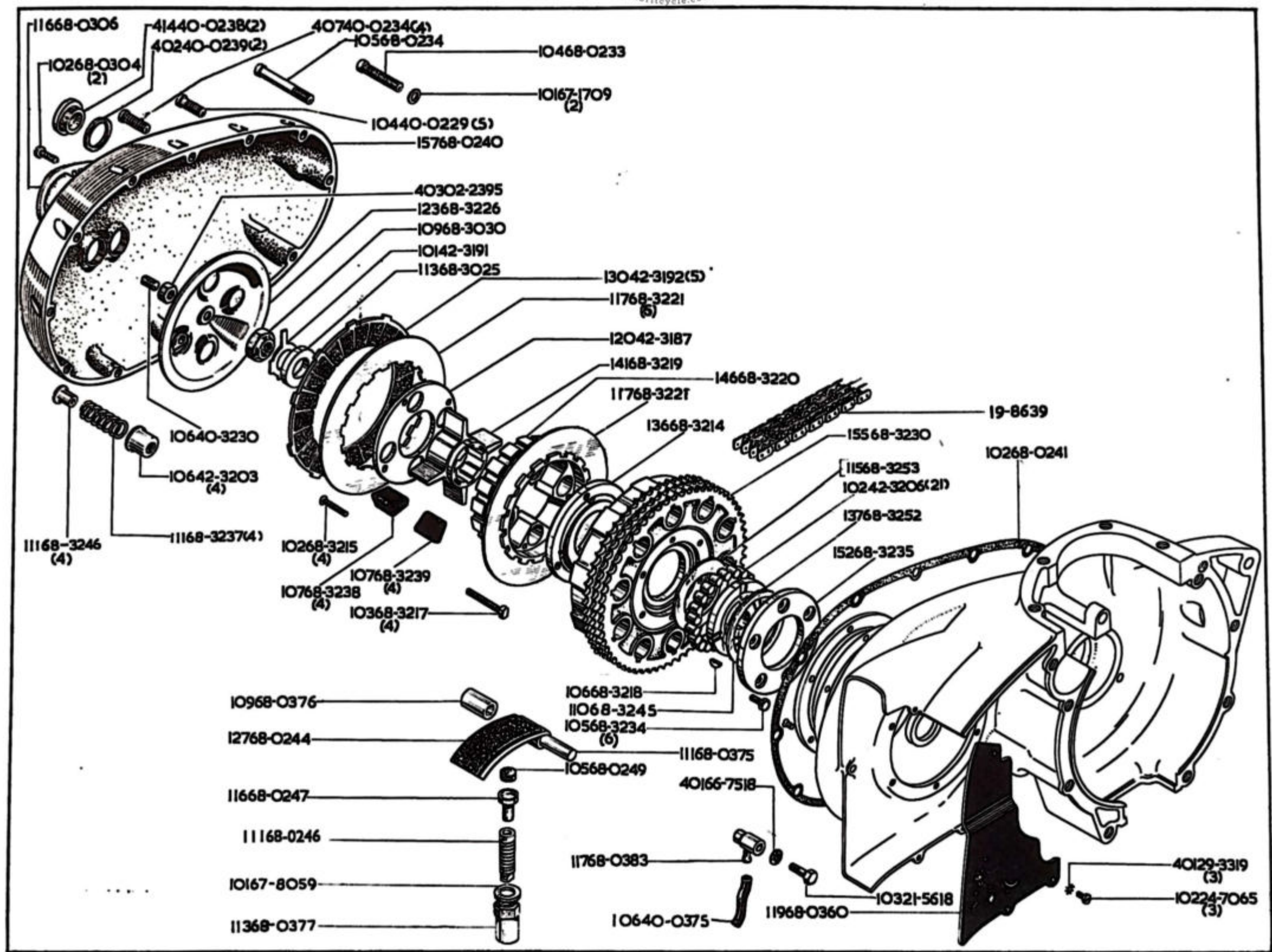

CLUTCH, EMBRAYAGE, KUPPLUNG, EMBRAGUE

Modele Modèle Typen Modelos	Spare No. No. de pièce Ersatzteil-Nr. No. de repuesto	Description	Designation	Beschreibueg	Descripción
	17 68-0383	Chain Oiler	Tube à graisse	Öler	Tubo de grasa
	13 68-3025	Washer	Rondelle	Scheibe	Arandela
	09 68-3030	Nut	Écrou	Mutter	Tuerca
	86 68-3206	Clutch complete	Embrague complet	Kupplung komplett	Embrague completo
	36 68-3214	Plate	Plaque	Haltescheibe	Placa retenadora
	02 68-3215	Screw	Vis	Schraube	Tornillo
	03 68-3217	Pin	Vis	Schraube	Tornillo
	06 68-3218	Sleeve Key	Clavette	Rundkeil	Chaveta Woodruff
	41 68-3219	Spider	Croisillon de l'embrayage	Kupplungskreuz	Estrella de embrague
	46 68-3220	Clutch Centre	Moyeux d'embrayage	Kupplungsnabe	Cubo de embrague
	17 68-3221	Driven Plate (fixed)	Disque entraîne	Reibscheibe	Disco accionado
	17 68-3221	Driven Plate	Disque entraîne	Reibscheibe	Disco accionado
	23 68-3226	Pressure Plate	Disque extérieur d'embrayage	Aussere Kupplungsscheibe	Disco exterior del embrague
	55 68-3230	Chainwheel	Couronne d'embrayage	Kupplungskettenrad	Piñón de cadena del embrague
	05 68-3234	Bolt	Boulon	Schraube	Tornillo
	52 68-3235	Plate	Plaque	Scheibe	Placa
	11 68-3237	Spring	Ressort	Feder	Resorte
	07 68-3238	Clutch Rubber	Tampon caoutchouc	Gummiauflage	Cojin de goma
	07 68-3239	Clutch Rubber	Tampon caoutchouc	Gummiauflage	Cojin de goma
	10 68-3245	Insert	Garniture	Einsatz	Garniture
	11 68-3246	Nut	Écrou	Mutter	Tuerca
	37 68-3252	Clutch Sleeve	Manchon de l'embrayage	Kupplungsmittelnehmer	Mangueto de embrague
	15 68-3253	Insert	Garniture	Einsatz	Garniture

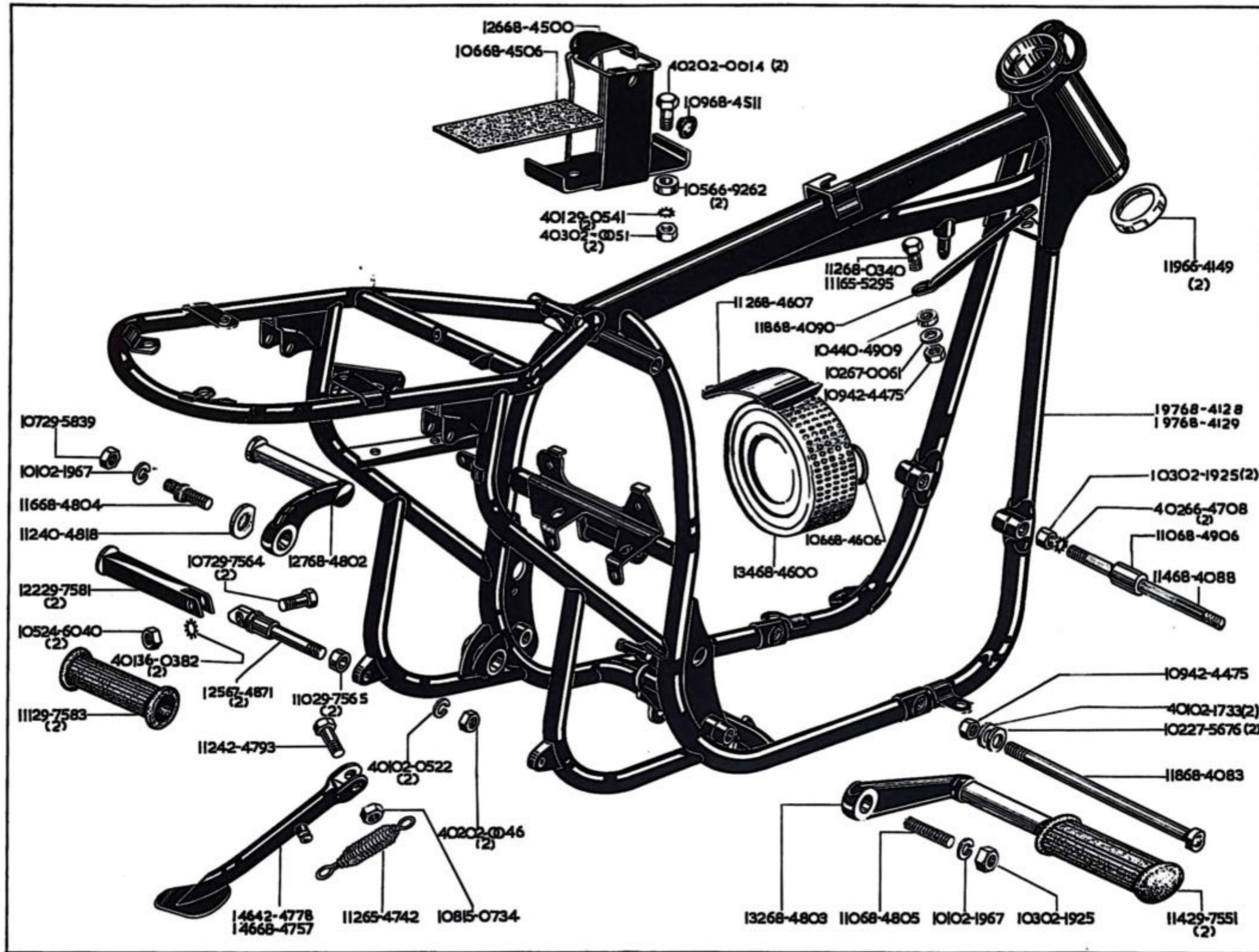

FRAME, CADRE, RAHMEN, CUADRO

Model Modèle Typen Modelos	Spares No. No. de pièce Ersatzteil-Nr. No. de repuesto	Description	Designation	Beschreibung	Descripción
A65T/R, S/H ...	02 02-0014	Bolt	Boulon	Schraube	Tornillo
A65T/R, L/R, A50C ...	02 02-0046	Nut	Écrou	Mutter	Tuerca
A65T/R, L/R ...	03 92-0051	Nut	Écrou	Mutter	Tuerca
A65T/R, L/R, A50C ...	01 02-0522	Washer	Rondelle	Scheibe	Arandela
	01 02-1733	Washer	Rondelle	Scheibe	Arandela
	03 02-1925	Nut	Écrou	Mutter	Tuerca
A65T/R, L/R ...	01 02-1967	Spring Washer	Rondelle	Scheibe	Arandela
	08 15-1734	Nut	Écrou	Mutter	Tuerca
A65T/R, L/R, A50C ...	05 24-6040	Nut	Écrou	Mutter	Tuerca
	02 27-5676	Washer	Rondelle	Scheibe	Arandela
A65T/R, L/R ...	01 29-0541	Washer	Rondelle	Scheibe	Arandela
A65T/R, L/R ...	07 29-5839	Nut	Écrou	Mutter	Tuerca
A65T/R, L/R ...	14 29-7551	Footrest Rubber	Caoutchouc de repose-pied	Fussrastengummi	Cojin de goma
A65T/R, L/R, A50C ...	07 29-7564	Bolt	Boulon	Schraube	Tornillo
A65T/R, L/R, A50C ...	10 29-7565	Distance Piece	Entretoise	Distanzrohr	Distanciador
A65T/R, L/R, A50C ...	22 29-7581	Pillion Footrest	Repose-pied arrière	Soziusfussrast	Descansa-pie para asiento trasera
A65T/R, L/R, A50C ...	11 29-7583	Footrest Rubber	Caoutchouc de repose-pied	Fussrastengummi	Cojin de goma
A65T/R, L/R, A50C ...	01 36-0382	Washer	Rondelle	Scheibe	Arandela
A65T/R, L/R ...	12 40-4818	Lock Plate	Plaque de blocage	Sicherung	Placa cerradora
A50C ...	04 40-4909	Distance Piece	Entretoise	Distanzrohr	Distanciador
	09 42-4475	Nut	Écrou	Mutter	Tuerca
A65L/R, A50C ...	46 42-4778	Prop Stand	Béquille latérale	Sitenstütze	Muleta lateral
A65T/R, L/R, A50C ...	42 42-4835	Pillion Footrests complete	Repose-pied arrière complet	Soziusbankfussrast	Estribo para acompañante
	12 42-4793	Bolt	Boulon	Schraube	Tornillo
	12 65-4742	Spring	Ressort	Feder	Resorte
A65T/R, S/H, L/R ...	11 65-5295	Bolt	Boulon	Schraube	Tornillo
A65T/R, L/R ...	19 66-4149	Bearing Cup	Couvette de roulement	Lagerschale	Copa de ralamiento
	02 66-4708	Washer	Rondelle	Scheibe	Arandela
A65T/R, L/R ...	05 66-9262	Distance Piece	Entretoise	Distanzrohr	Distanciador
	02 67-0061	Washer	Rondelle	Scheibe	Arandela
A65T/R, L/R, A50C ...	25 67-4871	Anchor Bolt	Boulon d'ancrage	Ankerbolzen	Tornillo de sujeción
A50C ...	12 68-0340	Bolt	Boulon	Schraube	Tornillo
	18 68-4083	Bolt	Boulon	Schraube	Tornillo
	14 68-4088	Stud	Goujon	Stehbolzen	Esparago
	18 68-4090	Stay	Tringle	Strebe	Tirante
A65T/R ...	97 68-4128	Frame complete	Cadre complet	Rahmen komplett	Cuadro completo
A65T/R ...	*97 68-4129	Frame complete	Cadre complet	Rahmen komplett	Cuadro completo
A65T/R, L/R ...	26 68-4500	Battery Carrier	Support de batterie	Batteriehalter	Porta-bateria
A65T/R, L/R ...	06 68-4506	Rubber Mat	Recouvrement caoutchouc	Gummibelag	Estera de goma
A65T/R, L/R ...	09 68-4511	Rubber Grommet	Virole caoutchouc	Gummitülle	Manguera de goma
A65T/R ...	34 68-4600	Air Cleaner	Filtre à air complet	Luftfilter komplett	Filtro de asperacion completo
A65T/R ...	06 68-4606	"O" Ring	Bague "O"	"O" Ring	Anillo "O"
A65T/R ...	12 68-4607	Water Deflector	Couvercle	Deckel	Tapa
A65T/R, S/H ...	46 68-4757	Prop Stand Leg	Béquille latérale	Sitenstütze	Muleta lateral
A65T/R, L/H ...	27 68-4802	Footrest (left-hand)	Repose-pied (gauche)	Fussraste (links)	Descansa-pie (izquierdo)
A65T/R, L/R ...	32 68-4803	Footrest (right-hand)	Repose-pied (droite)	Fussraste (rechts)	Descansa-pie (derecho)
A65T/R, L/R ...	16 68-4804	Stud	Goujon	Stehbolzen	Esparago
A65T/R, L/R ...	10 68-4805	Stud	Goujon	Stehbolzen	Esparago
A65T/R ...	10 68-4906	Distance Piece	Entretoise	Distanzrohr	Distanciador

*Sidecar.

*Side-car.

*Beiwagen.

*Side-car.

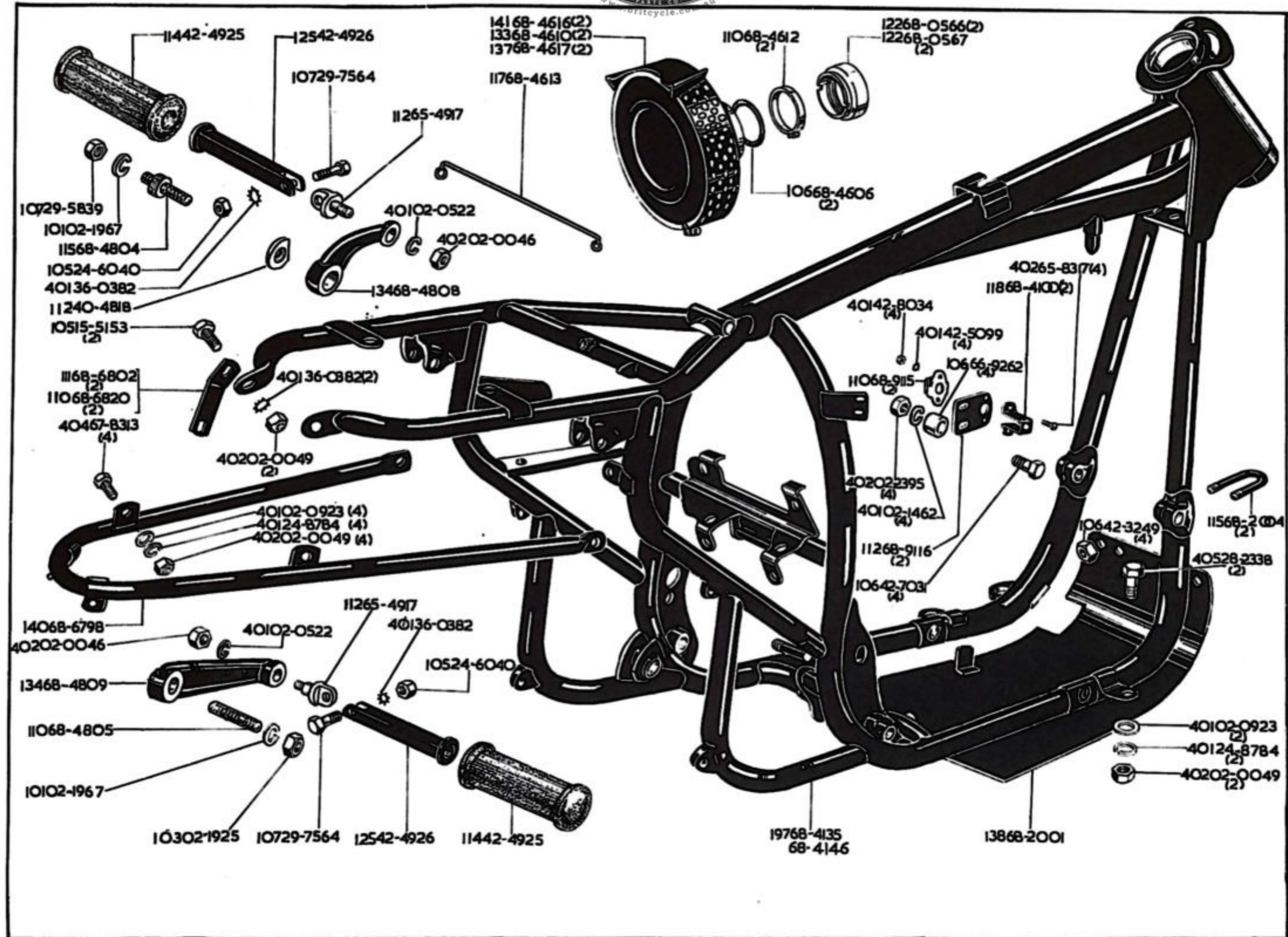

FRAME, CADRE, RAHMEN, CUADRO

Model Modèle Typen Modelos	Spares No. No. de pièce Ersatzteil-Nr. No. de repuesto	Description	Designation	Beschreibung	Descripción
A50C, A65S/H ...	02 02-0046	Nut	Écrou	Mutter	Tuerca
A65L/R, S/H, A50C ...	02 02-0049	Nut	Écrou	Mutter	Tuerca
A50C, A65S/H ...	01 02-0522	Washer	Rondelle	Scheibe	Arandela
A65L/R, S/H, A50C ...	01 02-0923	Washer	Rondelle	Scheibe	Arandela
A50C, A65S/H, L/R ...	01 02-1462	Washer	Rondelle	Scheibe	Arandela
A50C, A65S/H ...	03 02-1925	Nut	Écrou	Mutter	Tuerca
A50C, A65S/H ...	01 02-1967	Washer	Rondelle	Scheibe	Arandela
A50C, A65S/H, L/R ...	02 02-2395	Nut	Écrou	Mutter	Tuerca
A65L/R ...	05 15-5153	Bolt	Boulon	Schraube	Tornillo
A50C, A65S/H ...	05 24-6040	Nut	Écrou	Mutter	Tuerca
A65L/R, S/H, A50C ...	01 24-8784	Washer	Rondelle	Scheibe	Arandela
A50C, A65S/H, L/R ...	05 28-2338	Bolt	Boulon	Schraube	Tornillo
A50C, A65S/H ...	07 29-5839	Nut	Écrou	Mutter	Tuerca
A50C, A65S/H ...	07 29-7564	Bolt	Boulon	Schraube	Tornillo
A50C, A65S/H, L/R ...	01 36-0382	Washer	Rondelle	Scheibe	Arandela
A50C, A65S/H ...	12 40-4818	Locking Plate	Plaque de blocage	Sicherung	Placa cerradora
A50C, A65S/H ...	06 42-3249	Nut	Écrou	Mutter	Tuerca
A50C, A65S/H ...	14 42-4925	Footrest Rubber	Caoutchouc de repose-pied	Fussrastengummi	Descansa-pie de goma
A50C, A65S/H ...	25 42-4926	Footrest complete	Repose-pied complet	Fussraste komplett	Descansa-pie completo
A50C, A65S/H, L/R ...	01 42-5099	Washer	Rondelle	Scheibe	Arandela
A50C, A65S/H, L/R ...	06 42-7031	Bolt	Boulon	Schraube	Tornillo
A50C, A65S/H ...	01 42-8034	Nut	Écrou	Mutter	Tuerca
A50C, A65S/H ...	12 65-4917	Anchor Bolt	Boulon d'ancrage	Ankerbolzen	Tornillo
A50C, A65S/H ...	02 65-8317	Screw	Vis	Schraube	Tuerca
A50C, A65S/H, L/R ...	06 66-9262	Distance Piece	Entretoise	Distanzrohr	Distanciador
A65L/R, S/H, A50C ...	04 67-8313	Bolt	Boulon	Schraube	Tornillo
A50C ...	22 68-0566	Adaptor	Pièce d'ajustement	Anschlussrohr	Tubo de ajuste
A65S/H, L/R ...	22 68-0567	Adaptor	Pièce d'ajustement	Anschlussrohr	Tubo de ajuste
A50C, A65S/H ...	38 68-2001	Engine Shield	Plaque couvercle	Abdeckplatte	Tapa del cojinete
A50C, A65S/H ...	15 68-2004	"U" Bolt	Boulon "U"	"U" Schraube	Tornillo "U"
A50C, A65S/H ...	18 68-4100	Support	Support	Halter	Soporte
A50C, A65S/H ...	98 68-4134	Frame complete	Cadre complet	Rahmen komplett	Cuadro completo
A50C, A65S/H ...	97 68-4135	Frame	Cadre	Rahmen	Cuadro
A65L/R ...	68-4146	Frame	Cadre	Rahmen	Cuadro
A65S/H ...	33 68-4610	Air Cleaner	Filtre à air	Luftfilter	Filtro de aire
A50C, A65S/H, L/R ...	10 68-4612	Clip	Bride	Klammer	Grapa
A50C, A65S/H, L/R ...	17 68-4613	Support Rod	Tige	Zugstange	Varilla
A65L/R, A50C ...	06 68-4606	"O" Ring	Bague "O"	"O" Ring	Anillo "O"
A65L/R ...	41 68-4616	Air Cleaner	Filtre à air	Luftfilter	Filtro de aire
A50C ...	37 68-4617	Air Cleaner	Filtre à air	Luftfilter	Filtro de aire
A50C, A65S/H ...	15 68-4804	Stud	Goujon	Stehbolzen	Esparago
A50C, A65S/H ...	10 68-4805	Stud	Goujon	Stehbolzen	Esparago
A50C, A65S/H ...	34 68-4808	Bracket (left-hand)	Bride	Verstrebung	Soporte
A50C, A65S/H ...	34 68-4809	Bracket (right-hand)	Bride	Verstrebung	Soporte
A65L/R, S/H, A50C ...	40 68-6798	Mudguard Stay	Tringle	Strebe	Tirante
A65S/H, A50C ...	11 68-6802	Bracket	Bride	Verstrebung	Soporte
A65L/R ...	10 68-6820	Bracket	Bride	Verstrebung	Soporte
A50C, A65S/H, L/R ...	10 68-9115	Oddie Clip	Bride	Klammer	Grapa
A50C, A65S/H, L/R ...	12 68-9116	Bracket	Bride	Verstrebung	Soporte

SWINGING ARM, BRAS OSCILLANT, SCHWINGARM, HORQUILLA OSCILLANTE

Model Modèle Typen Modelos	Spare No. No. de pièce Ersatzteil-Nr. No. de repuesto	Description	Designation	Beschreibung	Descripción
A65T/R	02 01-4606	Screw	Vis	Schraube	Tornillo
A65T/R	02 02-0049	Nut	Écrou	Mutter	Tuerca
A50C, A65S/H, L/R	02 02-0079	Screw	Vis	Schraube	Tornillo
	02 02-0443	Nut	Écrou	Mutter	Tuerca
	02 02-0449	Nut	Écrou	Mutter	Tuerca
	02 02-0510	Screw	Vis	Schraube	Tornillo
	01 02-0522	Washer	Rondelle	Scheibe	Arandela
A65T/R	01 02-0923	Washer	Rondelle	Scheibe	Arandela
	02 02-1027	Nut	Écrou	Mutter	Tuerca
A50C, A65L/R	01 02-1309	Screw	Vis	Schraube	Tornillo
A65T/R	01 02-1733	Washer	Rondelle	Scheibe	Arandela
	01 03-1346	Washer	Rondelle	Scheibe	Arandela
	07 03-1399	Bolt	Boulon	Schraube	Tornillo
	01 15-0039	Washer	Rondelle	Scheibe	Arandela
A50C, A65S/H, L/R	06 15-1312	Spring	Ressort	Feder	Resorte
A65T/R	01 15-5155	Washer	Rondelle	Scheibe	Arandela
	19-4614	Spring	Ressort	Feder	Resorte
A65T/R	* 19-4617	Spring	Ressort	Feder	Resorte
A65T/R	* 19-7413	Shock Absorber	Amortisseur	Stossdämpfer	Amortiguador
	19-7418	Shock Absorber	Amortisseur	Stossdämpfer	Amortiguador
A50C, A65S/H, L/R	02 21-5102	Nut	Écrou	Mutter	Tuerca
	02 24-0563	Nut	Écrou	Mutter	Tuerca
A65T/R	01 24-0978	Washer	Rondelle	Scheibe	Arandela
	05 24-5160	Nut	Écrou	Mutter	Tuerca
	01 24-8784	Washer	Rondelle	Scheibe	Arandela
A50C, A65S/H, L/R	02 25-6015	Washer	Rondelle	Scheibe	Arandela
	03 28-2080	Grease Nipple	Graisser	Schmiernippel	Engrasador
A50C, A65S/H, L/R	01 29-0541	Washer	Rondelle	Scheibe	Arandela
A50C, A65L/R, T/R	01 29-3319	Washer	Rondelle	Scheibe	Arandela
A65T/R	01 35-0706	Split Pin	Goupille fendue	Splint	Chaveta hendida
	01 35-0707	Split Pin	Goupille fendue	Splint	Chaveta hendida
	01 36-0382	Washer	Rondelle	Scheibe	Arandela
A65L/R	12 40-4076	Bolt	Boulon	Schraube	Tornillo
A50C, A65S/H	04 40-4909	Distance Piece	Entretoise	Distanzrohr	Distanciador
	29 42-4340	Spindle	Arbre	Welle	Arbol
	11 42-4343	Nut	Écrou	Mutter	Tuerca
A65T/R	31 42-4349	Cross Shaft	Arbre	Welle	Arbol
	28 42-4362	Bush	Douille	Büchse	Casquillo
	02 42-4364	Washer	Rondelle	Scheibe	Arandela
	09 42-4475	Nut	Écrou	Mutter	Tuerca
A65T/R	09 42-4476	Nut	Écrou	Mutter	Tuerca
A50C, A65S/H	19 42-4730	Spring	Ressort	Feder	Resorte
	11 42-4744	Spindle	Arbre	Welle	Arbol
	10 42-4745	Distance Tube	Entretoise	Distanzrohr	Distanciador
A65S/H, A50C Comp.	49 42-4762	Central Stand	Béquille centrale	Mittelständer	Muleta
A65S/H, L/R, A50C	07 42-5883	Nut	Écrou	Mutter	Tuerca

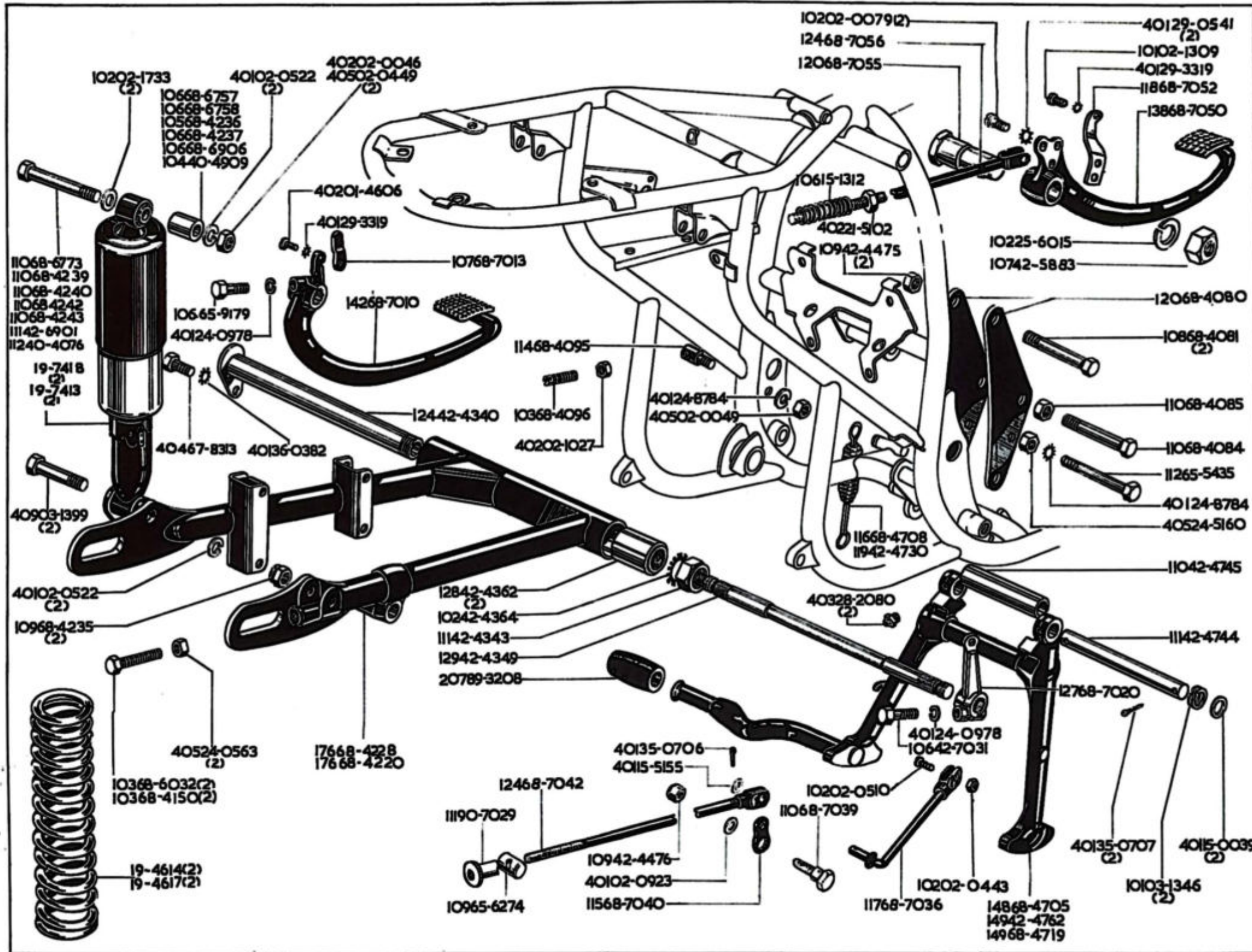

SWINGING ARM, BRAS OSCILLANT, SCHWINGARM, HORQUILLA OSCILLANTE

Model Modèle Typen Modelos	Spares No. No. de pièce Ersatzteil-Nr. No. de repuesto	Description	Designation	Beschreibung	Descripción
A65T/R	11 42-6901	Bolt	Boulon	Schraube	Tornillo
A65T/R	06 42-7031	Bolt	Boulon	Schraube	Tornillo
	12 65-5435	Bolt	Boulon	Schraube	Tornillo
	09 65-6274	Swivel Pin	Tourillon simple	Stift	Esparago
A65T/R	05 65-9179	Bolt	Boulon	Schraube	Tornillo
	04 67-8313	Bolt	Boulon	Schraube	Tornillo
	20 68-4080	Engine Plate	Plaque d'appui	Motorabstützblech	Placa de apoyo
	20 68-4080	Engine Plate	Plaque d'appui pour motor	Motorabstützblech	Placa de apoyo del motor
	08 68-4081	Bolt	Boulon	Schraube	Tornillo
	10 68-4084	Bolt	Boulon	Schraube	Tornillo
	10 68-4085	Nut	Écrou	Mutter	Tuerca
	14 68-4095	Adjuster Post	Boulon à oeil	Ösenbolzen	Tornillo de ojo
	03 68-4096	Screw	Vis	Schraube	Tornillo
A50C, A65S/H, L/R	03 68-4150	Bolt	Boulon	Schraube	Tornillillo
A65T/R	76 68-4220	Swinging Arm	Bras oscillant	Schwingarm	Horquilla
A65T/R	76 68-4220	Swinging Arm	Bras oscillant complet	Schwingarm komplett	Horquilla completo
A50C, A65S/H, L/R	76 68-4228	Swinging Arm	Bras oscillant complet	Schwingarm komplett	Horquilla completo
	09 68-4235	Nut	Écrou	Mutter	Tuerca
A65T/R, L/R	05 68-4236	Distance Piece	Entretoise	Distanzrohr	Distanciador
A65T/R, L/R	06 68-4237	Distance Piece	Entretoise	Distanzrohr	Distanciador
A50C, A65S/H, T/R	10 68-4239	Bolt	Boulon	Schraube	Tornillo
A65T/R	10 68-4240	Bolt	Boulon	Schraube	Tornillo
A50C, A65S/H	10 68-4242	Bolt	Boulon	Schraube	Tornillo
A65L/R, A50C	10 68-4243	Bolt	Boulon	Schraube	Tornillo
A50C ROAD MODEL, A65L/R, T/R.	48 68-4705	Central Stand	Béquille centrale	Mittelständer	Muleta
A50C, A65L/R, T/R	16 68-4708	Spring	Ressort	Feder	Resorte
A50C Comp., A65S/H	†49 68-4719	Central Stand	Béquille centrale	Mittelständer	Muleta
A65T/R	03 68-6032	Bolt	Boulon	Schraube	Tornillo
A65L/R, A50C	10 68-6773	Bolt	Boulon	Schraube	Tornillo
A50C, A65S/H	06 68-6906	Distance Piece	Entretoise	Distanzrohr	Distanciador
A65T/R	42 68-7010	Brake Pedal	Pédale de frein	Bremsbelag	Guarnición
A50C, A65L/R, T/R	07 68-7013	Lever	Levier	Hebel	Palanca
A65T/R	27 68-7020	Lever	Levier	Hebel	Palanca
A65T/R	17 68-7036	Brake Rod	Tringle de frein	Bremsstange	Tirante de freno
A65T/R	10 68-7039	Bolt	Boulon	Schraube	Tornillo
A65T/R	15 68-7040	Plate	Plaque	Scheibe	Placa
A65T/R	24 68-7042	Brake Rod	Tringle de frein	Bremsstange	Tirante de freno
A50C, A65S/H, L/R	38 68-7050	Rear Brake Pedal	Pédale de frein	Bremsbelag	Guarnición
A50C, A65S/H, L/R	18 68-7052	Bracket	Support	Verstrebung	Soporte
A50C, A65S/H, L/R	20 68-7055	Fulcrum Pin	Goupille de butée	Drehbolzen	Espiga
A50C, A65S/H, L/R	24 68-7056	Brake Rod	Tringle de frein	Bremsstange	Tirante de freno
A50C, A65L/R, T/R	67 89-3208	Rubber	Poignée en caoutchouc	Gummifestgriff	Puño fijo de goma
	11 90-7029	Nut	Écrou	Mutter	Tuerca
		*Sidecar. †1965 Models	*Side-car. †1965 Modèles	*Beiwagen. †Typen 1965	*Side-car. †1965 Modelos

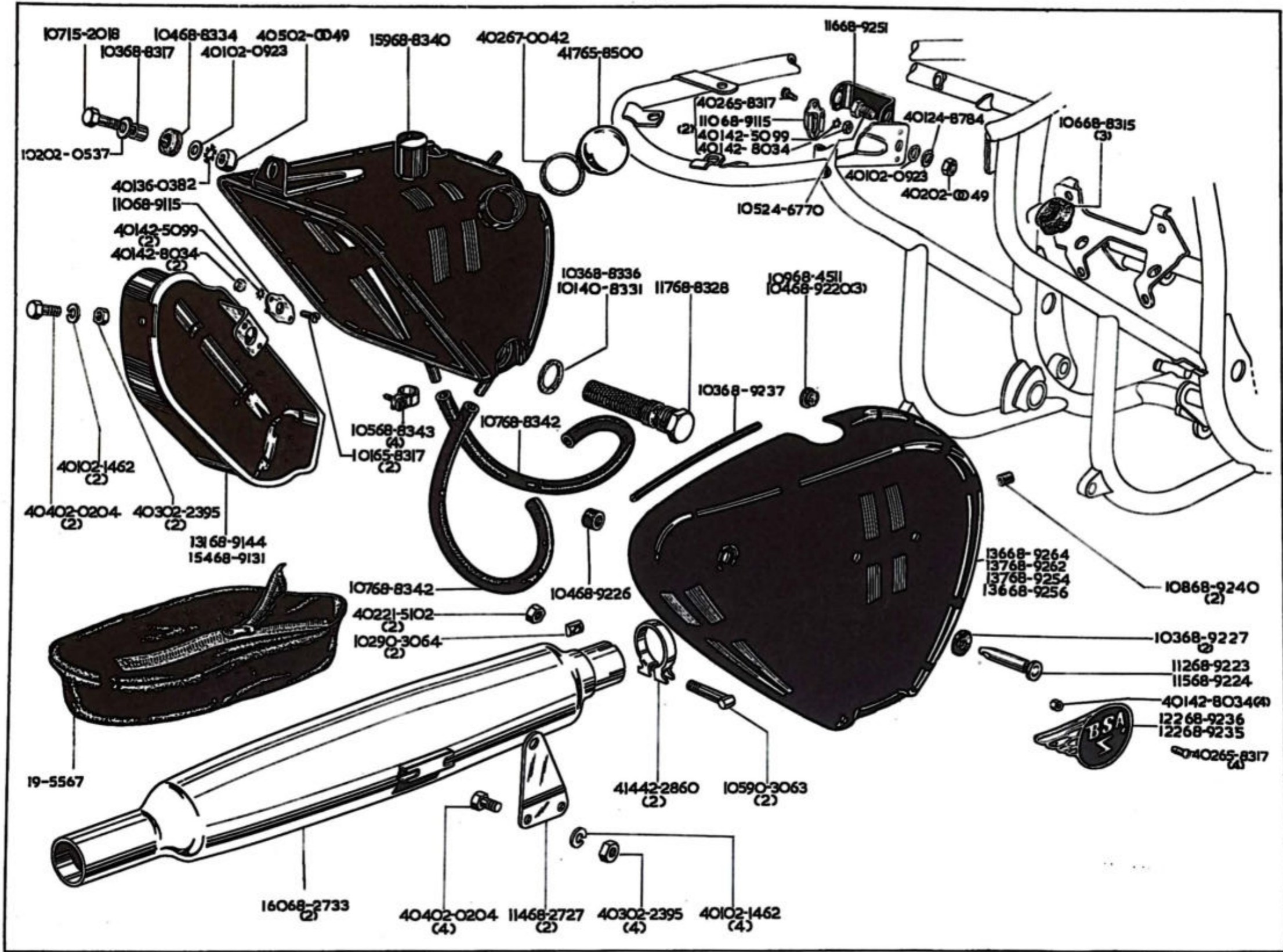

BRITCYCLE
OIL TANK, RÉSERVOIR D'HUILE, ÖLTANK, DEPOSITO DE ACEITE

Model Modèle Typen Modelos	Spares No. No. de pièce Ersatzteil-Nr. No. de repuesto	Description	Designation	Beschreibung	Descripción
	05 02-0049	Nut	Écrou	Mutter	Tuerca
	04 02-0204	Bolt	Boulon	Schraube	Tornillo
	02 02-0537	Washer	Rondelle	Scheibe	Arandela
	01 02-0923	Washer	Rondelle	Scheibe	Arandela
	01 02-1462	Lockwasher	Rondelle frein	Sicherung	Freno
	03 02-2395	Nut	Écrou	Mutter	Tuerca
	07 15-2018	Bolt	Boulon	Schraube	Tornillo
A65T/R, L/R, A50C ...	19-5567	Toolbag	Trousse à outils	Werkzeugtasche	Bolsa de herramientas
A65T/R, L/R, A50C ...	02 21-5102	Nut	Écrou	Mutter	Tuerca
A50C, A65L/R, S/H ...	01 21-5164	Nut	Écrou	Mutter	Tuerca
	05 24-6770	Bolt	Boulon	Schraube	Tornillo
	01 24-8784	Lockwasher	Rondelle frein	Sicherung	Freno
	01 36-0382	Lockwasher	Rondelle frein	Sicherung	Freno
A65T/R	01 40-8331	Fibre Washer	Rondelle-fibre	Fiberscheibe	Arandela fibre
A65T/R, L/R, A50C ...	14 42-2860	Clip	Bride	Klammer	Grapa
A65T/R, L/R, A50C ...	01 42-5099	Lockwasher	Rondelle frein	Sicherung	Freno
A65L/R, S/H, A50C ...	05 42-6554	Bolt	Boulon	Schraube	Tornillo
A65T/R, L/R, A50C ...	01 42-8034	Nut	Écrou	Mutter	Tuerca
	07 65-0292	Bolt	Boulon	Schraube	Tornillo
A65T/R, L/R, A50C ...	01 65-8317	Screw	Vis	Schraube	Tornillo
	17 67-8500	Filler Cap	Bouchon de remplissage	Verschlusskappe	Tapa
	02 67-0042	Fibre Washer	Rondelle-fibre	Fiberscheibe	Arandela fibre
A65T/R, L/R, A50C, ...	14 68-2727	Bracket	Support	Verstrebung	Soporte
A65T/R, L/R, A50C ...	60 68-2733	Silencer	Silencieux	Schalldämpfer	Silenciador
A65T/R, A50C, A65S/H	09 68-4511	Rubber Plug	Bouton caoutchouc	Gummistopfen	Tapón de goma
	06 68-8315	Rubber Pad	Tampon caoutchouc	Gummiaufgabe	Cojin de goma
	03 68-8317	Spacer Bush	Bague d'ecartement	Distanzbüchse	Anillo espaciador
	17 68-8328	Oil Filter	Filtre	Filter	Filtro
	04 68-8334	Grommet	Rondelle capuchon	Tülle	Manguera
A65L/R, S/H, A50C ...	03 68-8336	Fibre Washer	Rondelle-fibre	Fiberscheibe	Arandela fibre
	59 68-8340	Oil Tank	Réservoir d'huile	Ölbehälter	Deposito de aceite
	07 68-8342	Oil Feed and Return Pipe	Conduit ou canalisation d'huile	Schmierleitung	Conexión de engrase
	05 68-8343	Clip	Bride	Klammer	Grapa
A65T/R, L/R, A50C ...	10 68-9115	Fastener Clip	Bride	Klammer	Grapa
A65L/R, A50C	54 68-9131	Toolbox	Coffret à outils	Werkzeugkasten	Caja de herramientas

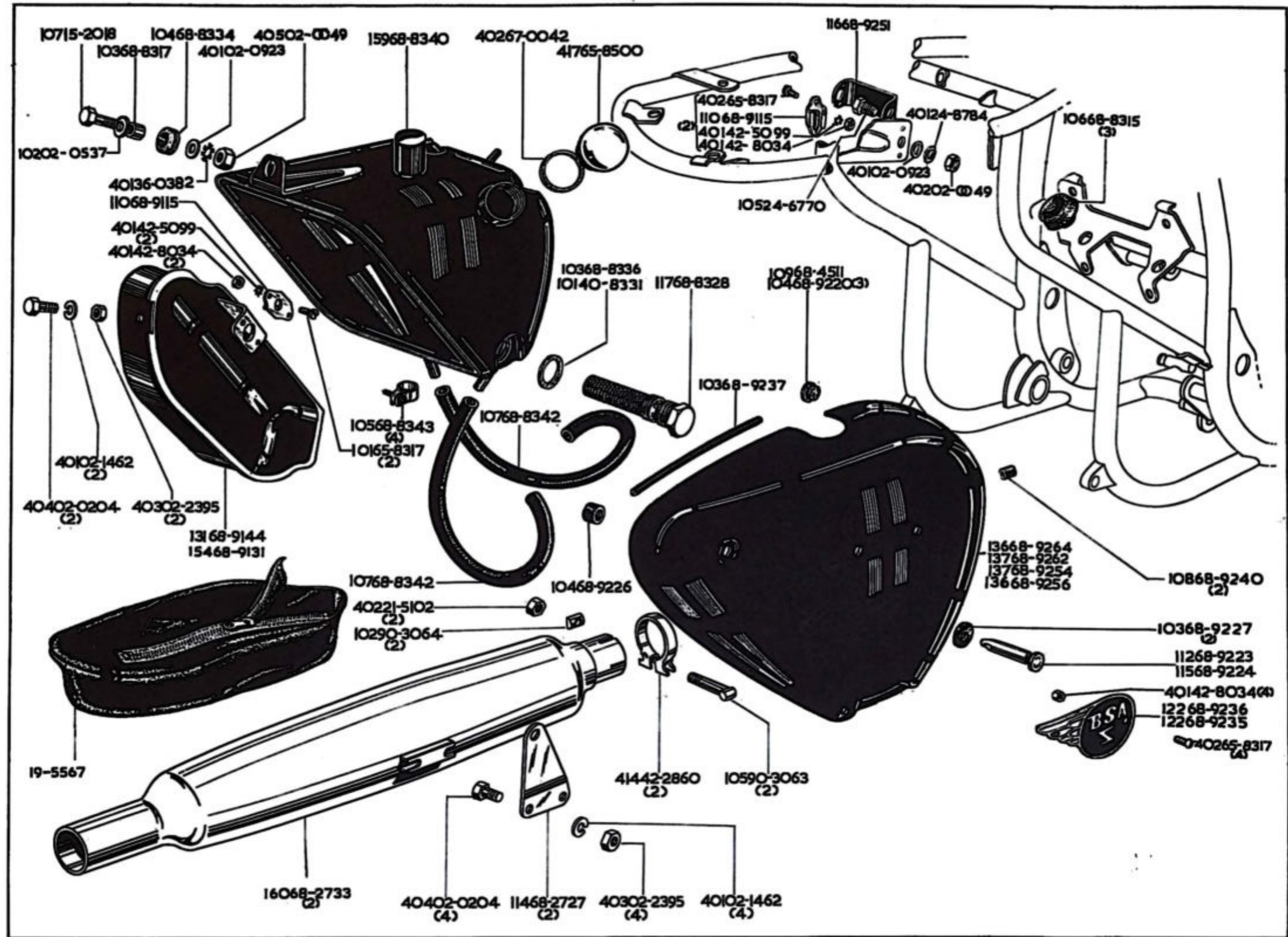

OIL TANK, RÉSERVOIR D'HUILE ÖLTANK, DEPOSITO DE ACEITE

Model Modèle Typen Modelos	Spares No. No. de pièce Ersatzteil-Nr. No. de repuesto	Description	Designation	Beschreibung	Descripción
A65T/R	31 68-9144	Toolbox	Coffret à outils	Werkzeugkasten	Caja de herramientas
A65T/R	04 68-9220	Rubber Pad	Tampon caoutchouc	Gummiauflage	Cojin de goma
A65T/R, L/R, A50C ...	12 68-9223	Stud	Goujon	Stehbolzen	Esparago
A65L/R, A50C	15 68-9224	Stud	Goujon	Stehbolzen	Esparago
A65T/R, L/R, S/H, A50C	04 68-9225	Rubber Sleeve	Douille caoutchouc	Gummimuffe	Manguita de goma
A65T/R, L/R, A50C ...	04 68-9226	Rubber Sleeve	Douille caoutchouc	Gummimuffe	Manguita de goma
A65T/R, L/R, A50C ...	03 68-9227	Grommet	Rondelle capuchon	Tülle	Manguera
A65T/R, L/R, A60C, S/H	22 68-9235	Badge (left-hand)	Écusson (droite)	Firmenzeichen (links)	Rotulo (izquierdo)
A65T/R, L/R, S/H, A50C	22 68-9236	Badge (right-hand)	Écusson	Firmenzeichen (rechts)	Rotulo (derecho)
A65T/R, L/R	03 68-9237	Rubber Bead (right-hand)	Molure	Zierleiste	Moldura
A65T/R	08 68-9240	Rubber Sleeve	Douille caoutchouc	Gummimuffe	Manguita de goma
	16 68-9251	Bracket	Support	Verstrebung	Soporte
A65T/R	37 68-9254	Sidecover (left-hand)	Panneau lateral (droite)	Seitenblech (links)	Panel de lado (izquierdo)
A65T/R	36 68-9256	Sidecover (right-hand)	Panneau lateral (gauche)	Seitenblech (rechts)	Panel de lado (derecho)
A65L/R, A50C	37 68-9262	Sidecover (left-hand)	Panneau lateral (droite)	Seitenblech (links)	Panel de lado (izquierdo)
A65L/R, A50C	36 68-9264	Sidecover (right-hand)	Panneau lateral (gauche)	Seitenblech (rechts)	Panel de lado (derecho)
A65T/R, L/R, A50C ...	05 90-3 063	"T" Bolt	Boulon	Schraube	Tornillo
A65T/R, L/R, A50C ...	02 90-3064	Saddle Washer	Rondelle de selles	Sattelscheibe	Arandela para sillín

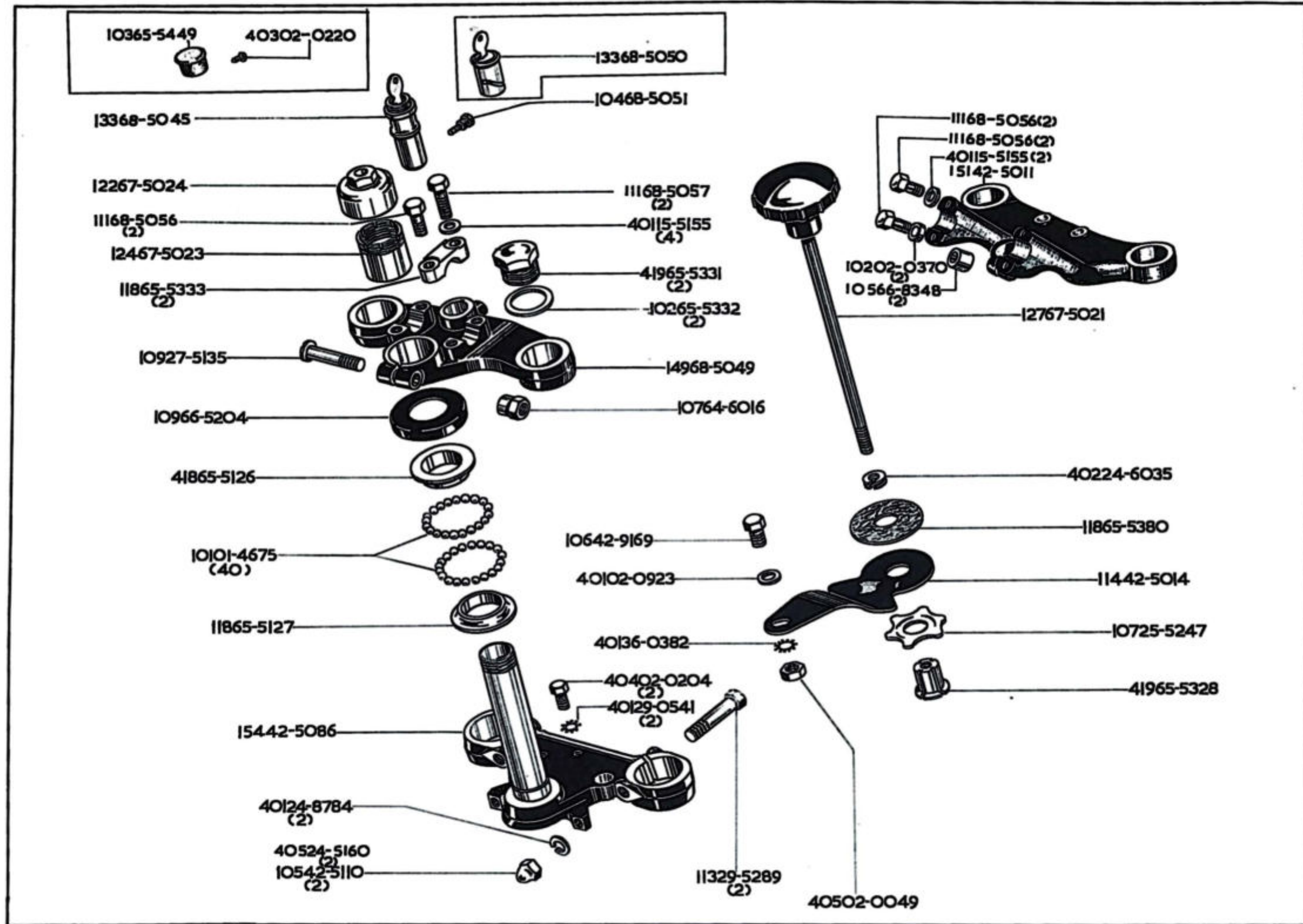

STEERING, DIRECTION, LENKUNG, DIRECCIÓN

Model Modèle Typen Modelos	Spares No. No. de pièce Ersatzteil-Nr. No. de repuesto	Description	Designation	Beschreibung	Descripción
	01 01-4675	Ball	Bille	Kugel	Bola
	05 02-0049	Nut	Écrou	Mutter	Tuerca
	04 02-0204	Bolt	Boulon	Schraube	Tornillo
	03 02-0220	Screw	Vis	Schraube	Tornillo
A65L/R, S/H	02 02-0370	Spacer Ring	Bague entretoise	Distanzring	Anillo espaciador
	01 02-0923	Washer	Rondelle	Scheibe	Arandela
	01 15-5155	Washer	Rondelle	Scheibe	Arandela
A65L/R, S/H, A50C	05 24-5160	Domed Nut	Écrou borgne	Hutmutter	Tuerca abovedada
	02 24-6035	Spring Washer	Rondelle	Scheibe	Arandela
	01 24-8784	Lockwasher	Rondelle frein	Sicherung	Freno
	07 25-5247	Star Washer	Rondelle en étoile	Sicherung	Freno
	09 27-5135	Clip Bolt	Boulon	Schraube	Tornillo
	01 29-0541	Lockwasher	Rondelle frein	Sicherung	Freno
	13 29-5289	Bottom Yoke Bolt	Boulon	Schraube	Tornillo
	01 36-0382	Lockwasher	Rondelle frein	Sicherung	Freno
A65S/H, A50C	51 42-5011	Top Yoke	Tête de fourche	Oberjoch	Horqueta (superior)
	14 42-5014	Anchor Plate	Plaque de ancrage	Ankerplatte	Soporte
	54 42-5086	Bottom Yoke	Attache (inférieur)	Unterjoch	Horqueta (inferior)
A65T/R	05 42-5110	Domed Nut	Écrou borgne	Hutmutter	Tuerca abovedada
	06 42-9169	Anchor Plate Bolt	Boulon	Schraube	Tornillo
	07 64-6016	Extension Nut	Écrou	Mutter	Tuerca
	18 65-5126	Top Cone	Cone (supérieur)	Oberkonus	Cona (superior)
	18 65-5127	Bottom Cone	Cone (inférieur)	Unterkonus	Cona (inferior)
	19 65-5328	Damper Centre	Écrou à collet	Halsmutter	Tuerca de collar
	19 65-5331	Tube Nut	Écrou (supérieur)	Obermutter	Tuerca (superior)
	02 65-5332	Washer	Rondelle	Scheibe	Arandela
	18 65-5333	Handlebar Clip	Bride	Klammer	Grapa
	18 65-5380	Friction Washer	Rondelle	Scheibe	Arandela
	03 65-5449	Rubber Plug	Bouton caoutchouc	Gummistopfen	Tampon de goma
	09 66-5204	Dust Cap	Chapeau	Abdeckkappe	Tapón
A65T/R	05 66-8348	Spacer	Bague d'écartement	Distanzbüchse	Anillo espaciador
	27 67-5021	Damper Rod	Système de réglage	Einstellschraube	Tornillo de ajuste
	24 67-5023	Adjuster Sleeve	Douille	Büchse	Casquillo
	22 67-5024	Sleeve Cap	Chapeau	Abdeckkappe	Tapón
A65L/R, T/R	†33 68-5045	Steering Lock	Serrure et clef	Schloss mit Schlüssel	Cerradura y llave
A65T/R, L/R	49 68-5049	Top Yoke	Tête de fourche	Oberjoch	Horqueta (superior)
A65T/R	33 68-5050	Steering Lock	Serrure et clef	Schloss mit Schlüssel	Cerradura y llave
A65T/R, T/R	04 68-5051	Screw	Vis	Schraube	Tornillo
A65S/H, A50C Comp.	11 68-5056	Bolt	Boulon	Schraube	Tornillo
A65T/R, L/R, A50C ROAD MODEL	†11 68-5056	Bolt	Boulon	Schraube	Tornillo
A65T/R, L/R, A50C ROAD MODEL	†11 68-5057	Bolt	Boulon	Schraube	Tornillo

†When Speedometer and Rev Counter are fitted.

†Equipé d'un compteur de vitesses et un compte tours.

†Ausgestattet mit Geschwindigkeitsmesser und Tourenzähler.

†Equipado con indicador de velocidad y contador de vueltas.

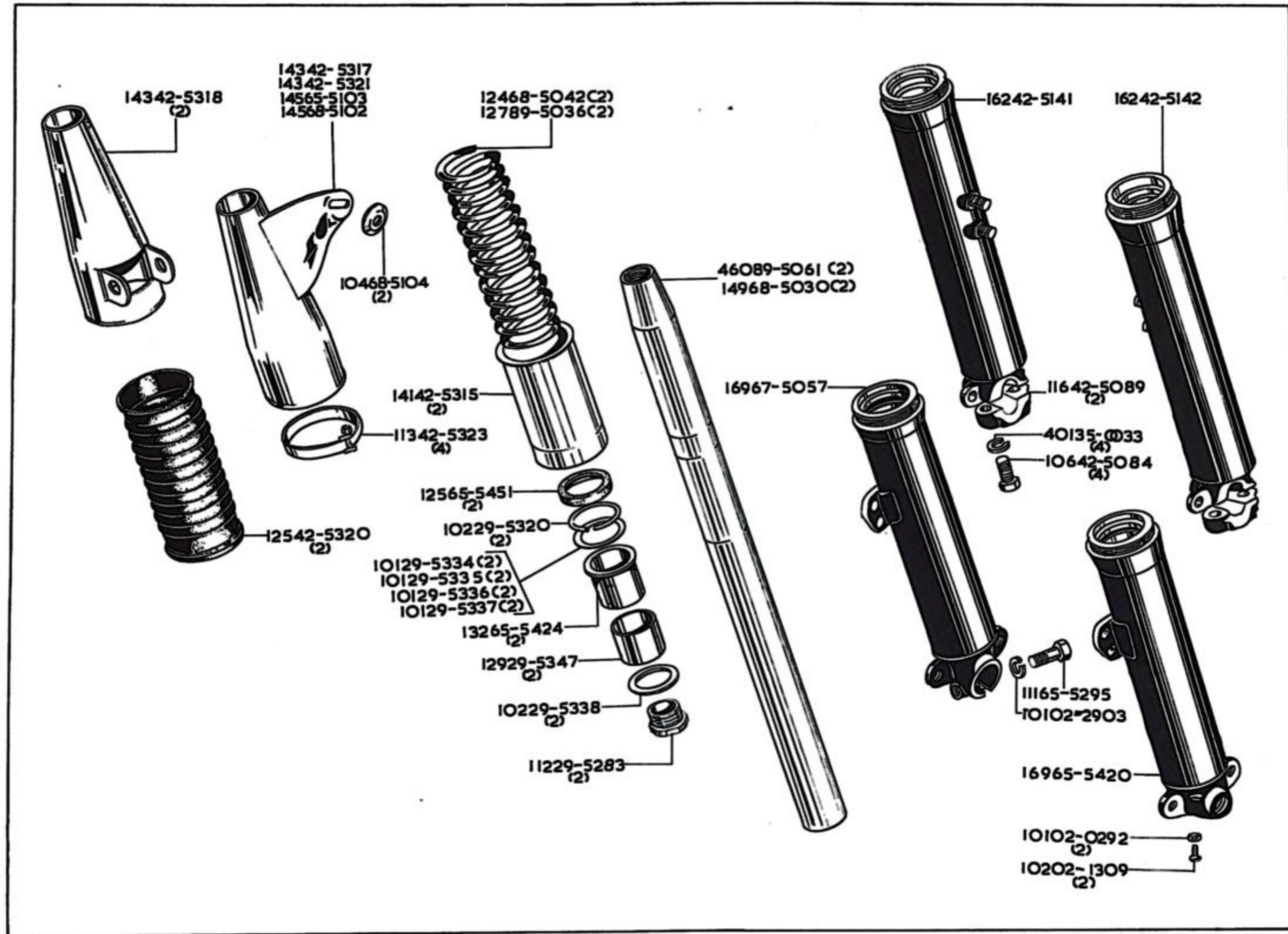

FRONT FORK, FOURCHE AVANT, VORDERGABEL, HORQUILLA DELANTERA

Model Modèle Typen Modelos	Spares No. No. de pièce Ersatzteil-Nr. No. de repuesto	Description	Designation	Beschreibung	Descripción
A65L/R, S/H, A50C	01 02-0292	Washer	Rondelle	Scheibe	Arandela
	02 02-1309	Drain Plug	Bouchon de vidange	Stopfen	Tapón de vaciado
	01 02-2903	Washer	Rondelle	Scheibe	Arandela
	12 29-5283	Plug	Bouchon	Stopfen	Tapón
	02 29-5320	Circlip	Arrêtoir	Sprengring	Freno
	01 29-5334	Shim (.005 in.)	Rondelle d'épaisseur (.127 mm.)	Ausgleichsscheibe (.127 mm.)	Espesor (.127 mm.)
	01 29-5335	Shim (.010 in.)	Rondelle d'épaisseur (.254 mm.)	Ausgleichsscheibe (.254 mm.)	Espesor (.254 mm.)
	01 29-5336	Shim (.020 in.)	Rondelle d'épaisseur (.508 mm.)	Ausgleichsscheibe (.508 mm.)	Espesor (.508 mm.)
	01 29-5337	Shim (.030 in.)	Rondelle d'épaisseur (.762 mm.)	Ausgleichsscheibe (.762 mm.)	Espesor (.762 mm.)
	02 29-5338	Washer	Rondelle	Scheibe	Arandela
	29 29-5347	Bearing	Roulement	Lager	Rolamiento
A65T/R	01 35-0033	Washer	Washle	Scheibe	Arandela
A65T/R	06 42-5084	Bolt	Boulon	Schraube	Tornillo
A65T/R	16 42-5089	End Cap	Chapeau	Abschlusskappe	Tapa cerradora
A65T/R	62 42-5141	Sliding Tube (nearside)	Tube coulissant (gauche)	Scheibeklaue (links)	Garra deslizantente (izquierdo)
A65T/R	62 42-5142	Sliding Tube (offside)	Tube coulissant (droite)	Scheibeklaue (rechts)	Garra deslizantente (derecho)
A50C	96 42-5146	Front Fork complete	Fourche avant complet	Vordergabel komplett	Horquilla delantera completo
A65S/H	97 42-5747	Front Fork complete	Fourche avant complet	Vordergabel komplett	Horquilla delantera completo
	41 42-5315	Oil Seal Holder	Boitier de joint d'huile	Dichtring Gehäuse	Caja reten de aceite
A50C	43 42-5317	Fork Sleeve (nearside)	Douille (gauche)	Büchse (links)	Casquillo (izquierdo)
A65S/H, A50C EAST COAST	*43 42-5318	Fork Sleeve	Douille	Büchse	Casquillo
	25 42-5320	Fork Bellows	Gaine souple d'étanchéité	Beigsame Dichtungshülle	Vaina flexible de cierre hermetico
A50C	43 42-5321	Fork Sleeve (offside)	Douille (droite)	Büchse (rechts)	Casquillo (derecho)
	13 42-5323	Clip	Bride	Klammer	Grapa
A65L/R, S/H, A50C	11 65-5295	Bolt	Boulon	Schraube	Tornillo
A65L/R, S/H, A50C	69 65-5420	Sliding Tube	Tube coulissant	Scheibeklaue	Garra deslizantente
	32 65-5424	Bearing	Roulement	Lager	Rolamiento
	25 65-5451	Oil Seal	Joint d'huile	Dichtring	Reten de aceite
A65L/R, S/H, A50C	69 67-5057	Sliding Tube	Tube coulissant	Scheibeklaue	Garra deslizantente
A65L/R, T/R	49 68-5030	Shaft	Arbre	Welle	Árbol
A65L/R, T/R	24 68-5042	Fork Spring	Ressort	Feder	Resorte
A65L/R, T/R	46 68-5059	Fork Sleeve (nearside)	Douille (gauche)	Büchse (links)	Casquillo (izquierdo)
A65L/R, T/R	46 68-5060	Fork Sleeve (offside)	Douille (droite)	Büchse (rechts)	Casquillo (derecho)
A65L/R	96 68-5070	Front Fork complete	Fourche avant complet	Vordergabel komplett	Horquilla delantera completo
A65T/R	96 68-5071	Front Fork complete	Fourche avant complet	Vordergabel komplett	Horquilla delantera completo
A65L/R, T/R	†45 68-5102	Fork Sleeve (right-hand)	Douille (droite)	Büchse (rechts)	Casquillo (derecho)
A65L/R, T/R	†45 68-5103	Fork Sleeve (left-hand)	Douille (gauche)	Büchse (links)	Casquillo (izquierdo)
A65L/R, T/R	†04 68-5104	Washer	Rondelle	Scheibe	Arandela
A50C ROAD MODEL,	†97 68-5110	Fork complete	Fourche complet	Vordergabel komplett	Horquilla completo
A65T/R	†97 68-5111	Fork complete	Douille complet	Vordergabel komplett	Horquilla completo
A65S/H, A50C Comp.	†97 68-5147	Fork complete	Douille complet	Vordergabel komplett	Horquilla completo
A65S/H, A50C	27 89-5036	Spring	Ressort	Feder	Resorte
A65S/H, A50C	60 89-5061	Fork Shaft	Arbre	Welle	Árbol

*Models without lighting.
†1965 models.

*Modèle sans éclairage.
†1965 modèles.

*Model Ohne Lichtenanlage.
†Typen 1965.

*Modelo sin alumbrado.
†Modelos 1965.

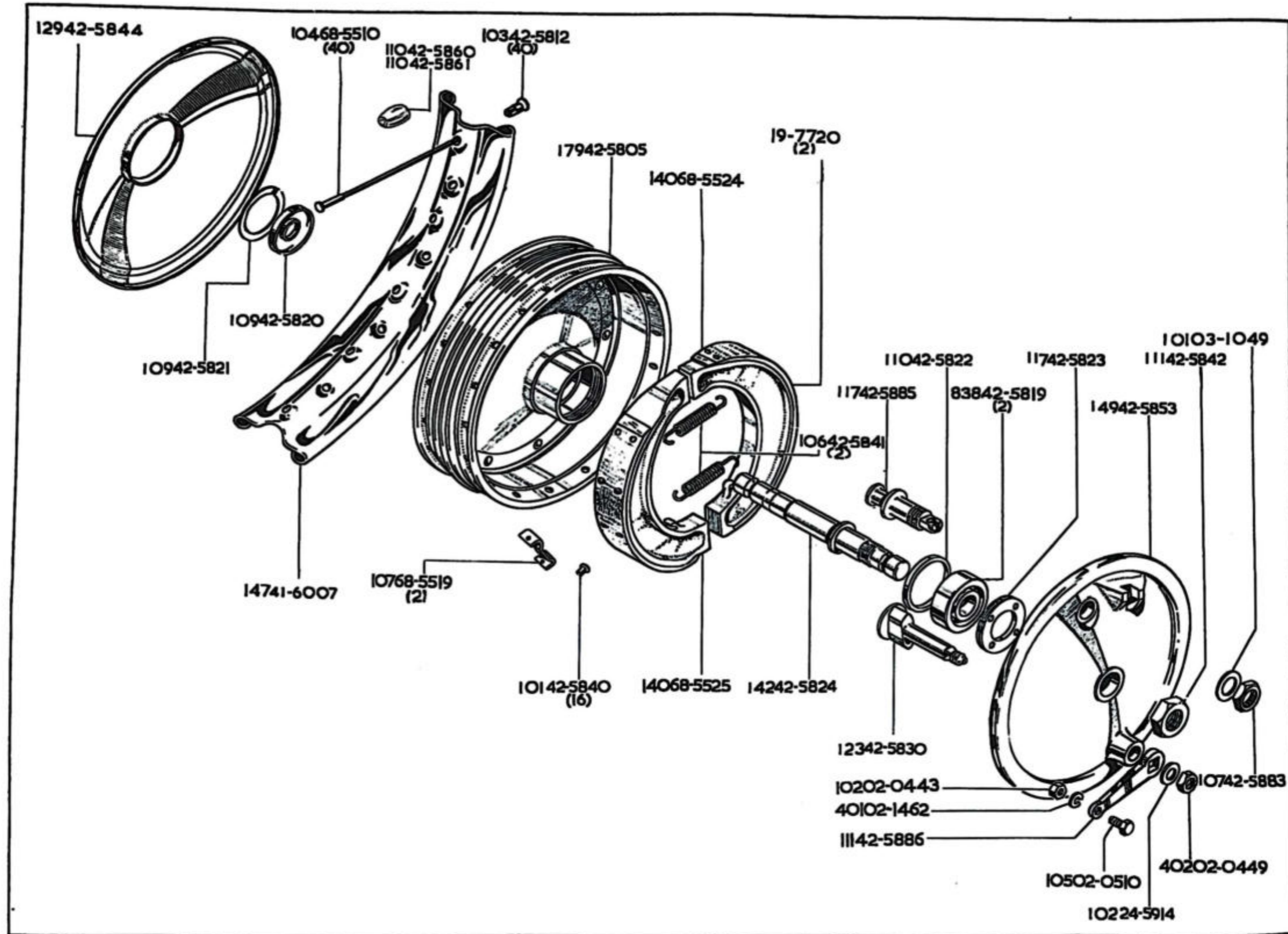

FRONT WHEEL, ROUE AVANT, VORDERRAD RUEDA DELANTERA

Model Modèle Typen Modelos	Spares No. No. de pièce Ersatzteil-Nr. No. de repuesto	Description	Designation	Beschreibung	Descripción
A65T/R	02 02-0443	Nut	Écrou	Mutter	Tuerca
A65T/R	02 02-0449	Nut	Écrou	Mutter	Tuerca
A65T/R	05 02-0510	Bolt	Boulon	Schraube	Tornillo
A65T/R	01 02-1462	Lockwasher	Rondelle frein	Sicherung	Freno
A65T/R	01 03-1049	Washer	Rondelle	Scheibe	Arandela
A65T/R	19-7720	Brake Lining	Garniture de frein	Bremsbelag	Guarnición
A65T/R	02 24-5914	Washer	Rondelle	Scheibe	Arandela
A65T/R	47 41-6007	Rim	Jante	Felge	Llanta
A65T/R	79 42-5805	Hub complete	Moyeu complet	Vorderradnabe komplett	Cubo completo
A65T/R	03 42-5812	Nipple	Écrou de rayon	Nippel	Tuerca
A65T/R	38 42-5819	Bearing	Roulement	Lager	Rolamiento
A65T/R	09 45-5820	Dust Cover	Couvercle	Schutzkappe	Tapa
A65T/R	09 45-5821	Circlip	Arrêtoir	Sprengring	Freno
A65T/R	10 42-5822	Spacer Ring	Bague entretoise	Distanzring	Distanciador
A65T/R	17 42-5823	Lock Ring	Arrêtoir	Sicherung	Freno
A65T/R	42 42-5824	Spindle	Arbre	Welle	Arbol
A65T/R	23 42-5830	Brake Cam	Came de frein	Bremsnocke	Llave de freno
A65T/R	01 42-5840	Rivet	Rivet	Niet	Remache
A65T/R	06 42-5841	Spring	Ressort	Feder	Resorte
A65T/R	11 42-5842	Nut	Écrou	Mutter	Tuerca
A65T/R	29 42-5844	Cover Plate	Plaque couvercle	Abdeckplatte	Tapa del cojinete
A65T/R	49 42-5853	Brake Cover Plate	Plaque couvercle	Abdeckplatte	Tapa del cojinete
A65T/R	10 42-5860	Balance Weight	Masse d'équilibrage	Gegengewicht	Masa de equilibrio
A65T/R	10 42-5861	Balance Weight	Masse d'équilibrage	Gegengewicht	Masa de equilibrio
A65T/R	07 42-5883	Nut	Écrou	Mutter	Tuerca
A65T/R	17 42-5885	Fulcrum Pin	Goupille de butée	Drehbolzen	Espiga
A65T/R	11 42-5886	Brake Lever	Levier de came de frein	Bremsnockenhebel	Palanca de freno
A65T/R	88 68-5506	Wheel complete	Roue complet	Vorderrad komplett	Rueda completo
A65T/R	04 68-5510	Spoke	Rayon	Speiche	Raio
A65T/R	07 68-5519	Brake Shoe Pad	Tampon	Auflage	Cojin
A65T/R	40 68-5524	Brake Shoe (leading)	Segment	Bremsbacke	Zapata
A65T/R	40 68-5525	Brake Shoe (trailing)	Segment	Bremsbacke	Zapata

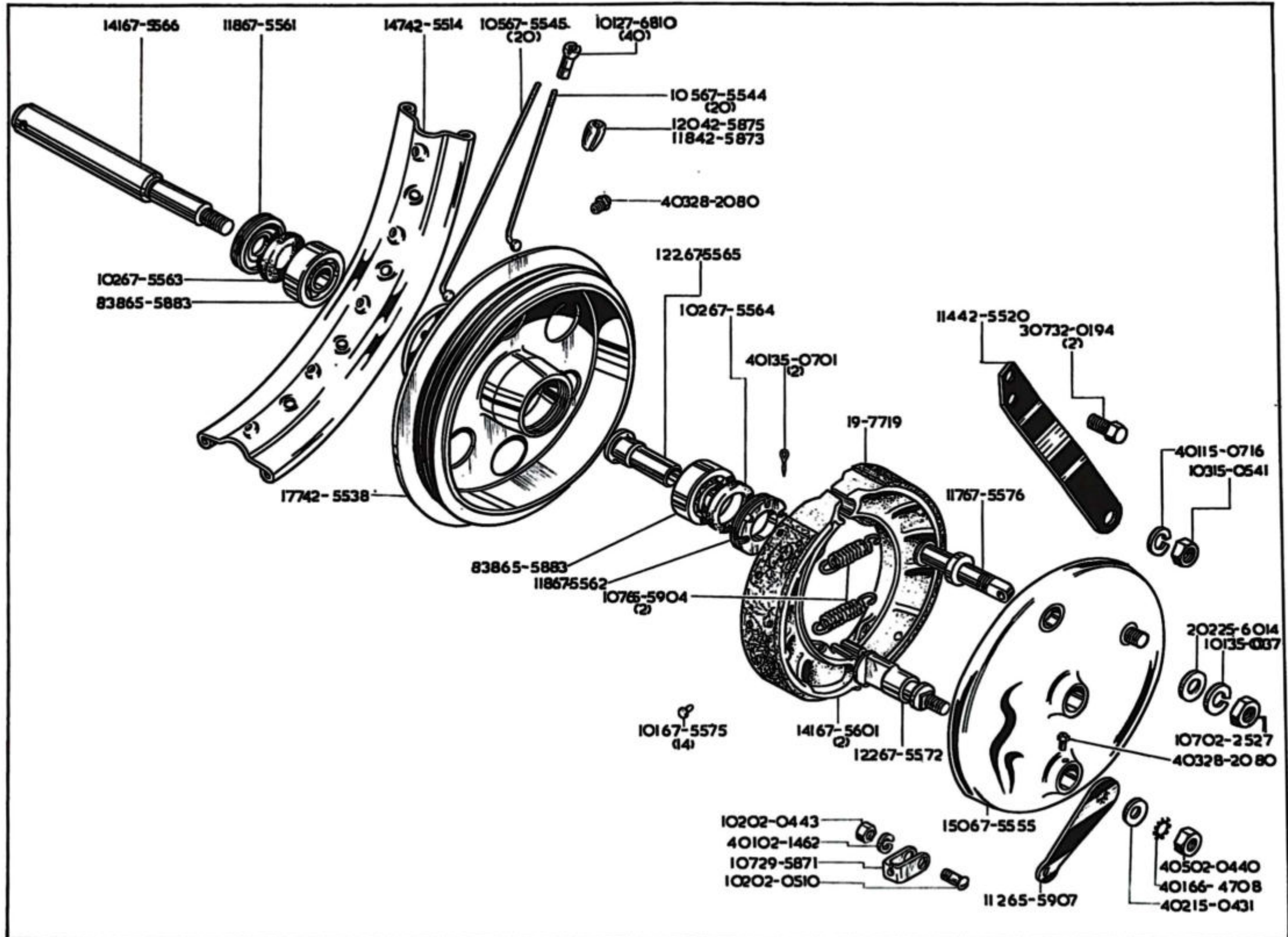

FRONT WHEEL, ROUE AVANT, VORDERRAD, RUEDA DELANTERA

Model Modèle Typen Modelos	Spares No. No. de piece Ersatzteil-Nr. No. de repuesto	Description	Designation	Beschreibung	Descripción
A65L/R, S/H, A50 2C ...	05 02-0440	Nut	Écrou	Mutter	Tuerca
A65L/R, S/H, A50 2C ...	02 02-0443	Nut	Écrou	Mutter	Tuerca
A65L/R, S/H, A50 2C ...	02 02-0510	Screw	Vis	Schraube	Tornillo
A65L/R, S/H, A50 2C ...	01 02-1462	Lockwasher	Rondelle frein	Sicherung	Freno
A65L/R, S/H, A50 2C ...	07 02-2527	Nut	Écrou	Mutter	Tuerca
A65L/R, S/H, A50 2C ...	02 15-0431	Washer	Rondelle	Scheibe	Arandela
A65L/R, S/H, A50 2C ...	03 15-0541	Nut	Écrou	Mutter	Tuerca
A65L/R, S/H, A50 2C ...	01 15-0716	Lockwasher	Rondelle frein	Sicherung	Freno
A65L/R, S/H, A50 2C ...	19-7719	Brake Lining	Garniture de frein	Bremsbelag	Guarnición
A65L/R, S/H, A50 2C ...	02 25-6014	Washer	Rondelle	Scheibe	Arandela
A65L/R, S/H, A50 2C ...	01 27-6810	Nipple	Écrou de rayon	Nippel	Tuerca
A65L/R, S/H, A50 2C ...	03 28-2080	Grease Nipple	Graisser	Schmiernippel	Engrasador
A65L/R, S/H, A50 2C ...	07 29-5871	Toggle	Genouillère	Knebelgelenk	Junta de codillo
A65L/R, S/H, A50 2C ...	07 32-0194	Bolt	Boulon	Schraube	Tornillo
A65L/R, S/H, A50 2C ...	01 35-0037	Lockwasher	Rondelle frein	Sicherung	Freno
A65L/R, S/H, A50 2C ...	01 35-0701	Split Pin	Goupille fendue	Splint	Chaveta hendida
A65L/R, S/H, A50 2C ...	84 42-5513	Wheel complete	Roue complet	Vorderrad komplett	Rueda completo
A65L/R, S/H, A50 2C ...	47 42-5514	Rim	Jante	Felge	Llanta
A65L/R, S/H, A50 2C ...	14 42-5520	Anchor Strap	Bride d'ancrage	Ankerhalterung	Anclaje de freno
A65L/R, S/H, A50 2C ...	77 42-5538	Hub complete	Moyeu complet	Vorderradnabe komplett	Cubo completo
A65L/R, S/H, A50 2C ...	18 42-5873	Balance Weight	Masse d'équilibrage	Gegengewicht	Masa de equilibrio
A65L/R, S/H, A50 2C ...	20 42-5875	Balance Weight	Masse d'équilibrage	Gegengewicht	Masa de equilibrio
A65L/R, S/H, A50 2C ...	38 65-5883	Bearing	Roulement	Lager	Rolamiento
A65L/R, S/H, A50 2C ...	07 65-5904	Spring	Ressort	Feder	Resorte
A65L/R, S/H, A50 2C ...	12 65-5907	Brake Lever	Levier de came de frein	Bremsnockenhebel	Palanca de freno
A65L/R, S/H, A50 2C ...	01 66-4708	Lockwasher	Rondelle frein	Sicherung	Freno
A65L/R, S/H, A50 2C ...	05 67-5544	Spoke (short)	Rayon (court)	Speiche (kurz)	Raio (corto)
A65L/R, S/H, A50 2C ...	05 67-5545	Spoke (long)	Rayon (longue)	Speiche (lang)	Raio (largo)
A65L/R, S/H, A50 2C ...	50 67-5555	Cover Plate	Plaque couvercle	Abdeckplatte	Tapa del cojinete
A65L/R, S/H, A50 2C ...	18 67-5561	Lock Ring	Arrêtoir	Sicherung	Freno
A65L/R, S/H, A50 2C ...	18 67-5562	Lock Ring	Arrêtoir	Sicherung	Freno
A65L/R, S/H, A50 2C ...	02 67-5563	Oil Retainer	Arrêtoir	Sicherung	Freno
A65L/R, S/H, A50 2C ...	02 67-5564	Oil Retainer	Arrêtoir	Sicherung	Freno
A65L/R, S/H, A50 2C ...	22 67-5565	Spindle Sleeve	Douille	Büchse	Casquillo
A65L/R, S/H, A50 2C ...	41 67-5566	Spindle	Arbre	Welle	Arbol
A65L/R, S/H, A50 2C ...	22 67-5572	Cam Spindle	Arbre	Welle	Arbol
A65L/R, S/H, A50 2C ...	01 67-5575	Rivet	Rivet	Niet	Remache
A65L/R, S/H, A50 2C ...	17 67-5576	Fulcrum Pin	Goupille de butée	Drehbolzen	Espiga
A65L/R, S/H, A50 2C ...	41 67-5601	Brake Shoe complete	Segment complet	Bremsbacke	Zapata

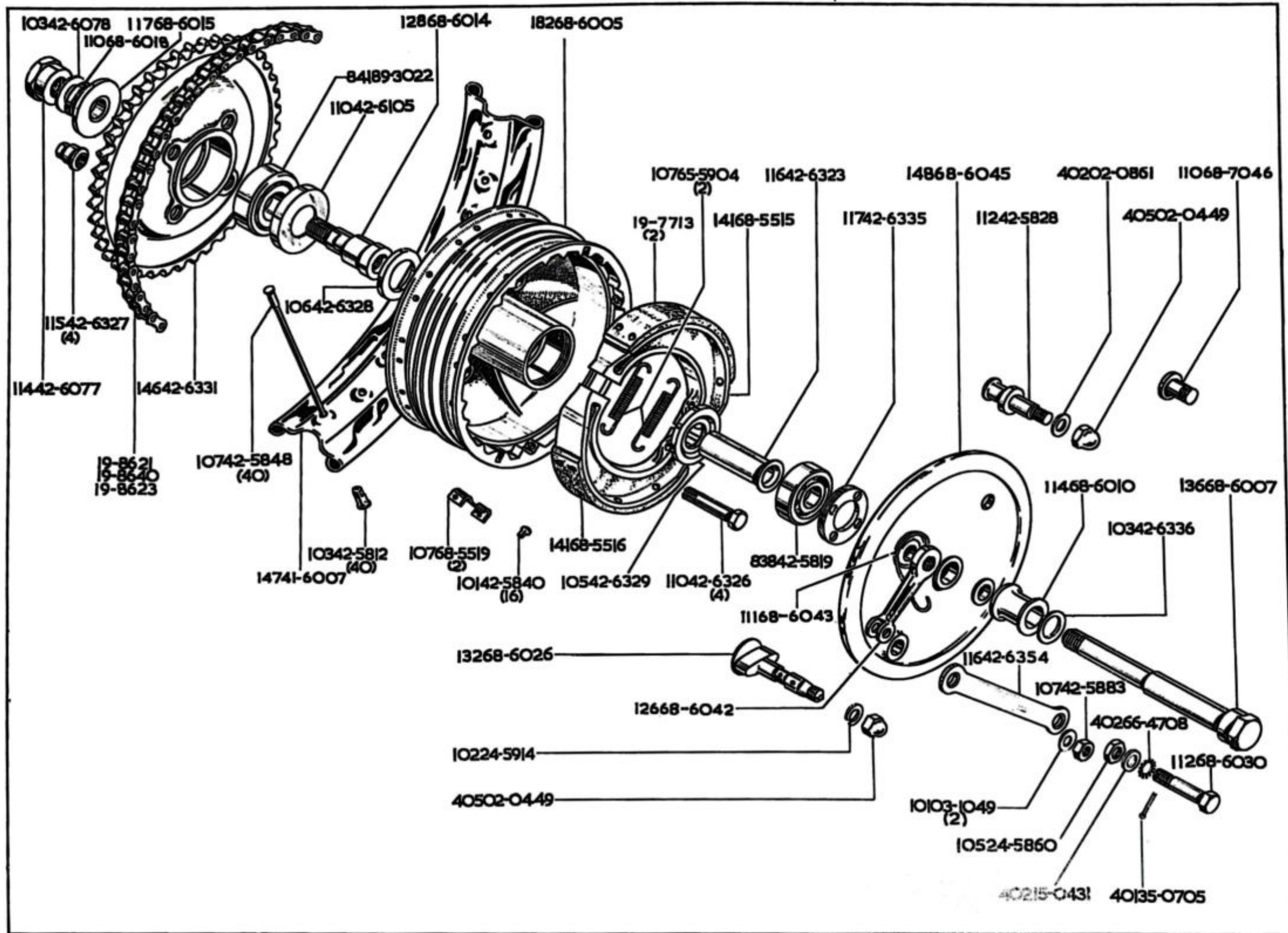

BRITCYCLE
REAR WHEEL, ROUE ARRIÈRE, HINTERRAD, RUEDA TRASERA

Model Modèle Typen Modelos	Spares No. No. de pièce Ersatzteil-Nr. No. de repuesto	Description	Designation	Beschreibung	Descripción
A65T/R	05 02-0449	Nut	Écrou	Mutter	Tuerca
A65T/R	02 02-0861	Washer	Rondelle	Scheibe	Arandela
A65T/R	01 03-1049	Washer	Rondelle	Scheibe	Arandela
A65T/R	02 15-0431	Washer	Rondelle	Scheibe	Arandela
A65T/R	19-7713	Lining	Garniture	Belag	Guarnición
A65T/R	* 19-8621	Chain	Chaîne	Kette	Cadena
A65T/R	19-8623	Chain	Chaîne	Kette	Cadena
A65T/R	† 19-8640	Chain	Chaîne	Kette	Cadena
A65T/R	05 24-5860	Nut	Écrou	Mutter	Tuerca
A65T/R	02 24-5914	Washer	Rondelle	Scheibe	Arandela
A65T/R	01 35-0705	Split Pin	Goupille fendue	Splint	Chaveta hendida
A65T/R	47 41-6007	Rim	Jante	Felge	Llanta
A65T/R	03 42-5812	Nipple	Écrou de rayon	Nippel	Tuerca
A65T/R	38 42-5819	Bearing	Roulement	Lager	Rolamiento
A65T/R	12 42-5828	Fulcrum Pin	Goupille de butée	Drehbolzen	Espiga
A65T/R	01 42-5840	Rivet	Rivet	Niet	Remache
A65T/R	07 42-5848	Spoke	Rayon	Speiche	Raio
A65T/R	07 42-5883	Nut	Écrou	Mutter	Tuerca
A65T/R	14 42-6077	Nut	Écrou	Mutter	Tuerca
A65T/R	03 42-6078	Washer	Rondelle	Scheibe	Arandela
A65T/R	10 42-6105	Retainer	Arrêtoir	Sicherung	Freno
A65T/R	16 42-6323	Distance Piece	Entretoise	Distanzrohr	Distanciadador
A65T/R	10 42-6326	Bolt	Boulon	Schraube	Tornillo
A65T/R	15 42-6327	Nut	Écrou	Mutter	Tuerca
A65T/R	06 42-6328	Dust Cover	Couvercle	Schutzkappe	Tapa
A65T/R	05 42-6329	Abutment Ring	Couvercle	Schutzkappe	Tapa
A65T/R	46 42-6331	Sprocket	Pignon à chaîne	Ritzel	Piñón
A65T/R	17 42-6335	Retaining Ring	Arrêtoir	Sicherung	Placa cerradora
A65T/R	03 42-6336	Washer	Rondelle	Scheibe	Arandela
A65T/R	16 42-6354	Strap	Bride	Strebe	Soporte
A65T/R	07 65-5904	Spring	Ressort	Feder	Resorte
A65T/R	02 66-4708	Washer	Rondelle	Scheibe	Arandela
A65T/R	41 68-5515	Brake Shoe Assembly	Segment complet	Bremsbacke komplett	Zapata completo
A65T/R	41 68-5516	Brake Shoe Assembly	Segment complet	Bremsbacke komplett	Zapata completo
A65T/R	07 68-5519	Pad	Tampon	Auflage	Cojin
A65T/R	89 68-6001	Wheel complete	Roue complet	Vorderrad komplett	Rueda completo
A65T/R	82 68-6005	Hub complete	Moyeu complet	Vorderradnabe komplett	Cubo completo
A65T/R	36 68-6007	Spindle	Arbre	Welle	Arbol
A65T/R	14 68-6010	Distance Collar	Entretoise	Distanzrohr	Distanciadador
A65T/R	28 68-6014	Spindle	Arbre	Welle	Arbol
A65T/R	17 68-6015	Distance Collar	Entretoise	Distanzrohr	Distanciadador
A65T/R	10 68-6018	Washer	Rondelle	Scheibe	Arandela
A65T/R	32 68-6026	Brake Cam	Came de frein	Bremsnocke	Llave de freno
A65T/R	12 68-6030	Bolt	Boulon	Schraube	Tornillo
A65T/R	26 68-6042	Brake Lever	Levier de frein	Bremshebel	Palanca de freno
A65T/R	11 68-6043	Spring	Ressort	Feder	Resorte
A65T/R	48 68-6045	Anchor Plate	Plaque d'ancrage	Ankerplatte	Soporte
A65T/R	10 68-7046	Anchor Bolt	Boulon d'ancrage	Ankerbolzen	Tornillo de sujeción
A65T/R	41 89-3022	Bearing	Roulement	Lager	Rolamiento
		*Sidecar.	*Side-car.	*Beiwagen.	*Side-car.
		†Fitted up to engine No. A65C-502.	†Monté avant moteur numéro A65C-502.	†Montiert bis Motor Nummer A65C-502.	†Montada hasta de motor numero A65C-502.

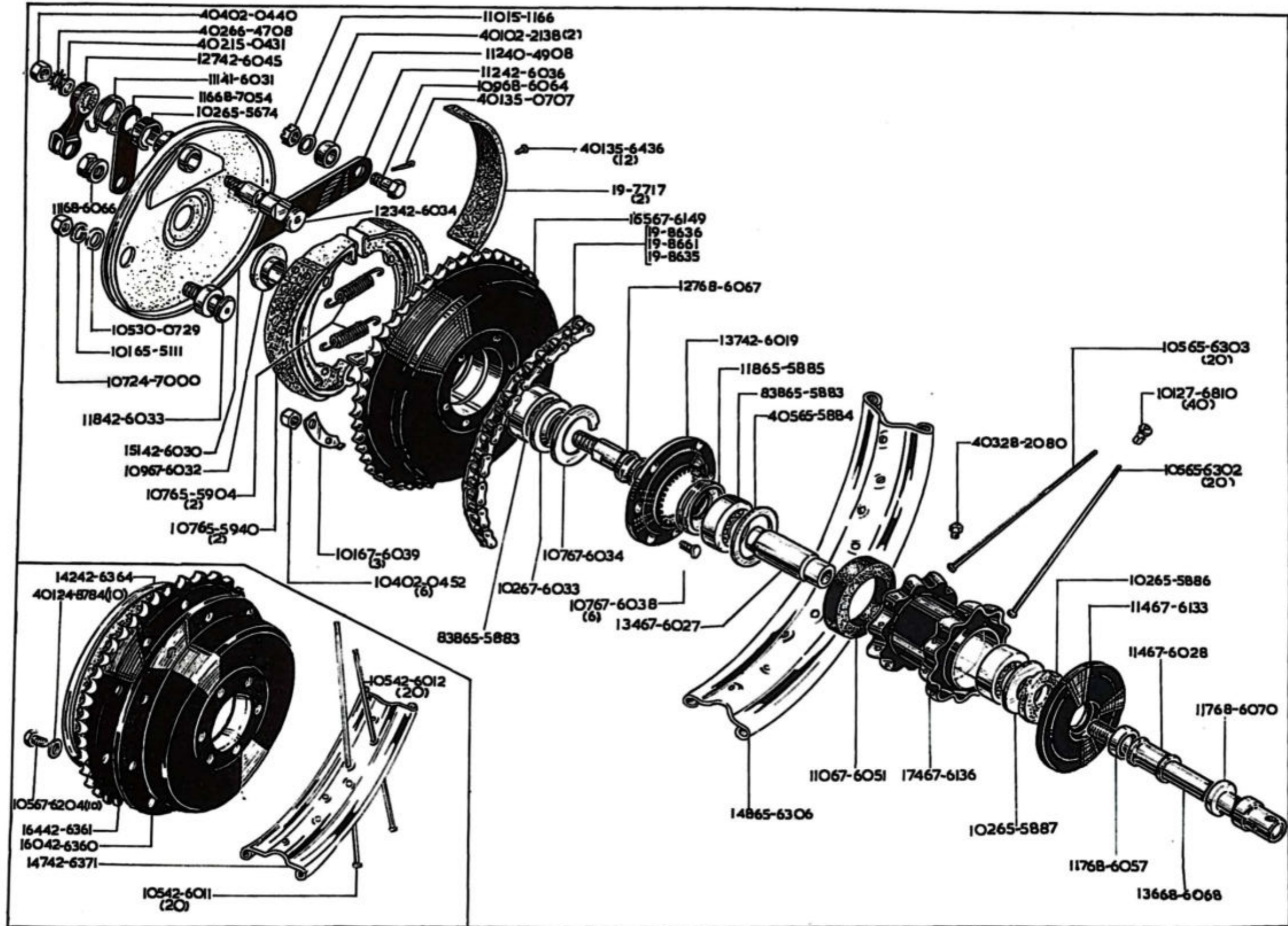

REAR WHEEL, ROUE ARRIÈRE, HINTERRAD, RUEDA TRASERA

Model Modèle Typen Modelos	Spares No. No. de pièce Ersatzteil-Nr. No. de repuesto	Description	Designation	Beschreibung	Descripción
A65L/R	04 02-0440	Nut	Écrou	Mutter	Tuerca
A65L/R	04 02-0452	Nut	Écrou	Mutter	Tuerca
A65L/R	01 02-2138	Washer	Rondelle	Scheibe	Arandela
A65L/R	02 15-0431	Washer	Rondelle	Scheibe	Arandela
A65L/R	10 15-1166	Nut	Écrou	Mutter	Tuerca
A65L/R	19-7717	Lining	Garniture	Belag	Guarnición
A65L/R	* 19-8635	Chain	Chaîne	Kette	Cadena
A65L/R	19-8636	Chain	Chaîne	Kette	Cadena
A50C, A65S/H	19-8661	Chain	Chaîne	Kette	Cadena
A65L/R	07 24-7000	Nut	Écrou	Mutter	Tuerca
A50C, A65S/H	01 24-8784	Spring Washer	Rondelle	Scheibe	Arandela
A65L/R	01 27-6810	Nipple	Écrou de rayon	Nippel	Tuerca
A65L/R	03 28-2080	Grease Nipple	Graisseur	Schmiernippel	Engrasador
A65L/R	05 30-0729	Washer	Rondelle	Scheibe	Arandela
A65L/R	01 35-0707	Split Pin	Goupille fendue	Splint	Chaveta hendida
A65L/R	01 35-6436	Rivet	Rivet	Niet	Remache
A65L/R	12 40-4908	Distance Piece	Entretoise	Distanzrohr	Distanciador
A65L/R	11 41-6031	Spring	Ressort	Feder	Resorte
A50C, A65S/H	05 42-6011	Spoke	Rayon	Speiche	Raio
A50C, A65S/H	05 42-6012	Spoke	Rayon	Speiche	Raio
A65L/R	37 42-6019	Driving Flange	Bride	Flansch	Gualderas
A65L/R	51 42-6030	Cover Plate	Plaque couvercle	Abdeckplatte	Tapa del cojinete
A65L/R	18 42-6033	Fulcrum Pin	Goupille de butée	Drehbolzen	Espiga
A65L/R	23 42-6034	Brake Cam	Came de frein	Bremsnocke	Llave de freno
A65L/R	12 42-6036	Strap	Bride	Strebe	Soporte
A65L/R	27 42-6045	Operating Lever	Levier	Hebel	Palanca
A50C, A65S/H	60 42-6360	Brake Drum	Tambour de frein	Bremstrommel	Tambor del freno
A50C, A65S/H	64 42-6361	Detachable Chainwheel	Pignon de chaîne	Kettenrad	Piñón de cadena
A50C, A65S/H	42 42-6364	Cover Plate	Plaque couvercle	Abdeckplatte	Tapa del cojinete
A50C, A65S/H	47 42-6371	Rim	Jante	Felge	Llanta
A65L/R	01 65-5111	Washer	Rondelle	Scheibe	Arandela
A65L/R	02 65-5674	Clip	Bride	Klammer	Grapa
A65L/R	38 65-5883	Bearing	Roulement	Lager	Rolamiento
65L/R	05 65-5884	Thrust Washer	Rondelle de butée	Druckscheibe	Anillo de empuje

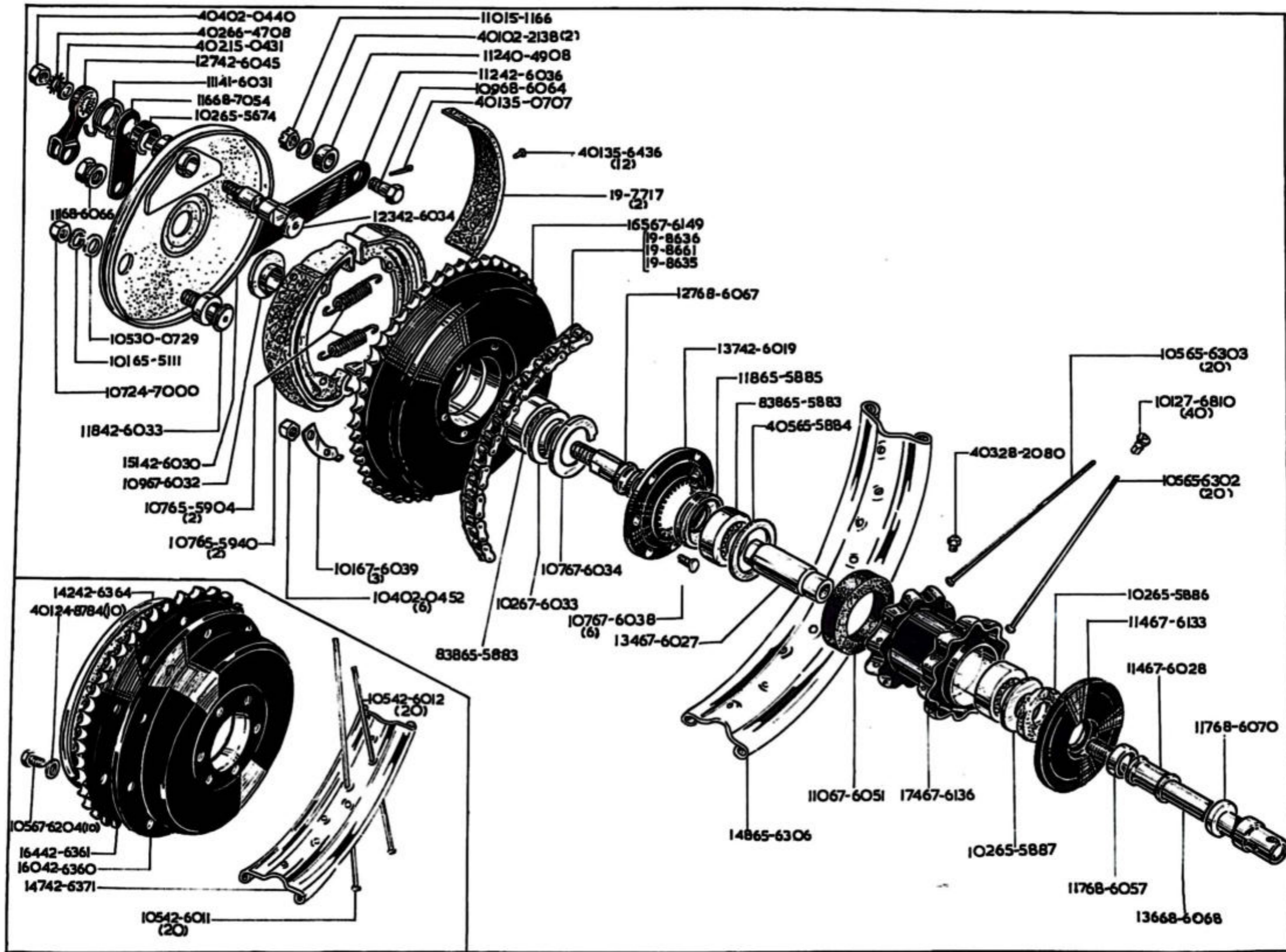

R EAR WHEEL, ROUE ARRIÈRE, HINTERRAD, RUEDA TRASERA

Model Modèle Typen Modelos	Spares No. No. de pièce Ersatzteil-Nr. No. de repuesto	Description	Designation	Beschreibung	Descripción
A65L/R	18 65-5885	Retaining Ring	Arrêtoir	Sicherung	Freno
A65L/R	02 65-5886	Felt Washer	Rondelle feutre	Filzscheibe	Arandela de fieltro
A65L/R	02 65-5887	Retaining Ring	Arrêtoir	Sicherung	Freno
A65L/R	07 65-5904	Spring	Ressort	Feder	Ressorte
A65L/R	07 65-5940	Brake Shoe	Segment	Bremsbacke	Zapata
A65L/R	05 65-6302	Spoke	Rayon	Speiche	Raio
A65L/R	05 65-6303	Spoke	Rayon	Speiche	Raio
A65L/R	48 65-6306	Rim	Jante	Felge	Llanta
A65L/R	02 66-4708	Washer	Rondelle	Scheibe	Arandela
A65L/R	34 67-6027	Sleeve	Douille	Büchse	Casquillo
A65L/R	14 67-6028	Distance Piece	Entretoise	Distanzrohr	Distanciador
A65L/R	09 67-6032	Hub Collar	Bague d'arrêt	Stelling	Anillo móvil aprisionado
A65L/R	02 67-6033	Shim	Rondelle d'épaisseur	Scheibe	Espesor
A65L/R	07 67-6034	Retainer	Arrêtoir	Sicherung	Freno
A65L/R	07 67-6038	Bolt	Boulon	Schraube	Tornillo
A65L/R	01 67-6039	Locking Plate	Plaque de blocage	Sicherung	Placa cerradora
A65L/R	10 67-6051	Washer	Rondelle	Scheibe	Arandela
A65L/R	14 67-6133	End Cover	Chapeau	Abschlusskappe	Tapa cerradora
A65L/R	74 67-6136	Hub	Moyeu	Vorderradnabe	Cubo
A65L/R	65 67-6149	Chainwheel (42T)	Pignon de chaîne (D-42)	Kettenrad (Z-42)	Piñón de cadena (D-42)
A50C	05 67-6204	Bolt	Boulon	Schraube	Tornillo
A65L/R	89 68-6050	Rear Wheel	Roue arrière	Hinterrad	Rueda trasera
A50C, A65S/H	89 68-6052	Rear Wheel	Roue arrière	Hinterrad	Rueda trasera
A65L/R	17 68-6057	Distance Collar	Entretoise	Distanzrohr	Distanciador
A65L/R	09 68-6064	Bolt	Boulon	Schraube	Tornillo
A65L/R	11 68-6066	Nut	Écrou	Mutter	Tuerca
A65L/R	27 68-6067	Fixed Spindle	Arbre	Welle	Arbol
A65L/R	36 68-6068	Spindle	Arbre	Welle	Arbol
A65L/R	17 68-6070	Distance Collar	Entretoise	Distanzrohr	Distanciador
A65L/R	16 68-7054	Strap	Bride	Strebe	Soporte

*Fitted up to Engine
No. A65D 615.

*Monté avant moteur
numéro A65D 615.

*Montiert bis Motornummer
A65D 615.

*Montada hasta de motor
numero A65D 615.

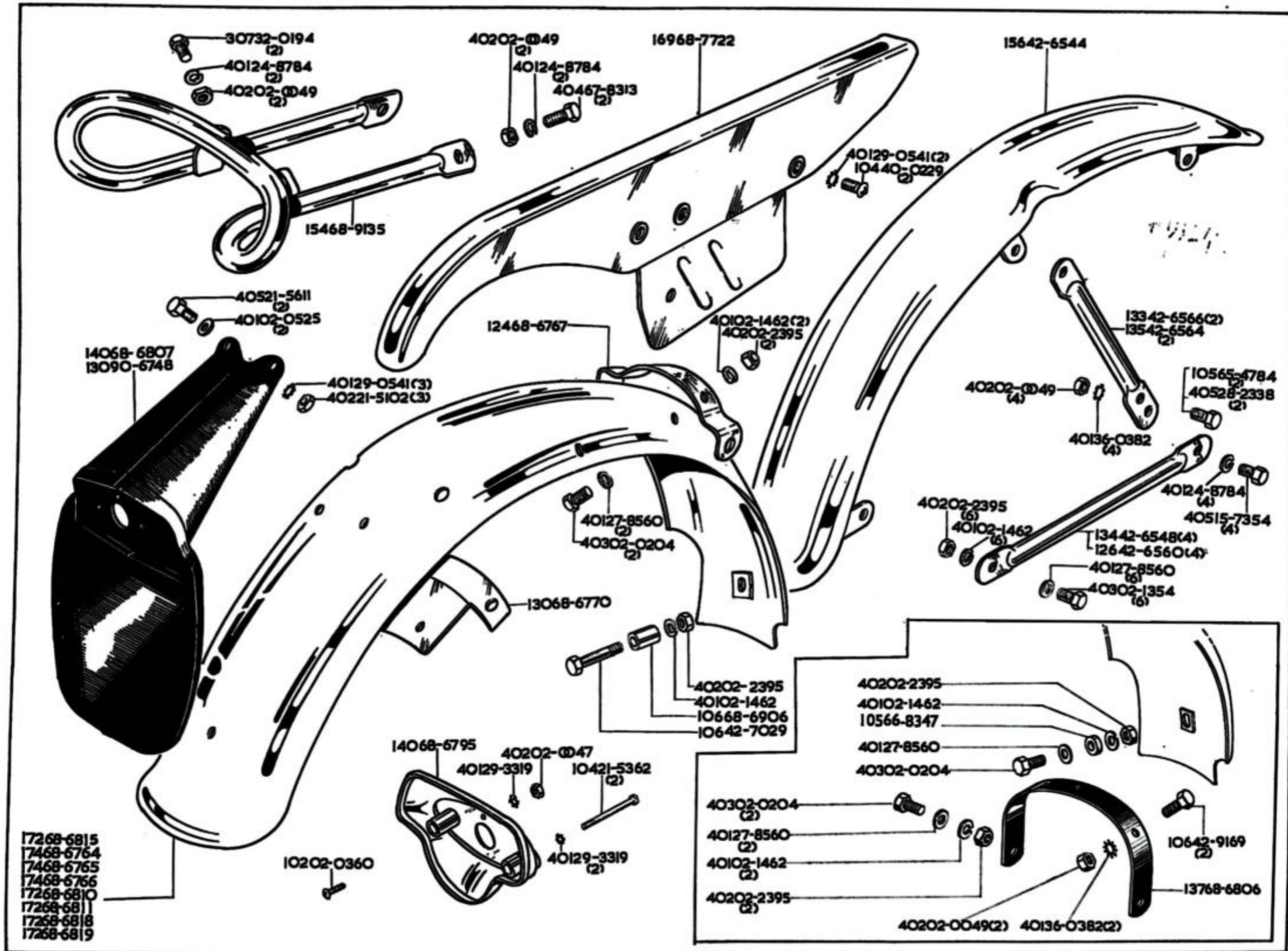

BRITCYCLE
MUDGUARDS, GARDE-BOUE, SCHUTZBLECH, GUARDABARROS

Model Modèle Typen Modelos	Spares No. No. de pièce Ersatzteil-Nr. No. de repuesto	Description	Designation	Beschreibung	Descripción
A65T/R, A65L/R, A50C ROAD MODEL.	02 02-0047	Nut	Écrou	Mutter	Tuerca
A50C, A65S/H, L/R ...	02 02-0049	Nut	Écrou	Mutter	Tuerca
A50C, A65S/H, L/R ...	03 02-0204	Bolt	Boulon	Schraube	Tornillo
A65T/R, A65L/R, A50C ROAD MODEL.	02 02-0360	Screw	Vis	Schraube	Tornillo
A50C, A65L/R ...	01 02-0525	Washer	Rondelle	Scheibe	Arandela
A50C, A65S/H, L/R ...	03 02-1354	Bolt	Boulon	Schraube	Tornillo
A50C, A65S/H, L/R ...	01 02-1462	Washer	Rondelle	Scheibe	Arandela
A50C, A65S/H, L/R ...	02 02-2395	Nut	Écrou	Mutter	Tuerca
A50C, A65S/H, L/R ...	05 15-7354	Bolt	Boulon	Schraube	Tornillo
A50C, A65L/R ...	02 21-5102	Nut	Écrou	Mutter	Tuerca
A65T/R, A65L/R, A50C ROAD MODEL.	04 21-5362	Bolt	Boulon	Schraube	Tornillo
A50C, A65L/R ...	05 21-5611	Bolt	Boulon	Schraube	Tornillo
A50C, A65S/H, L/R ...	01 24-8784	Washer	Rondelle	Scheibe	Arandela
A50C, A65S/H, L/R ...	01 27-8560	Washer	Rondelle	Scheibe	Arandela
A50C, A65S/H, L/R ...	05 28-2338	Bolt	Boulon	Schraube	Tornillo
A50C, A65S/H, L/R ...	01 29-0541	Washer	Rondelle	Scheibe	Arandela
A65T/R, A65L/R, A50C ROAD MODEL.	01 29-3319	Washer	Rondelle	Scheibe	Arandela
A65L/R ...	07 32-0194	Bolt	Boulon	Schraube	Tornillo
A50C, A65S/H, L/R ...	01 36-0382	Washer	Rondelle	Scheibe	Arandela
A50C, A65S/H, L/R ...	04 40-0229	Screw	Vis	Schraube	Tornillo
A50C, A65S/H, L/R ...	56 42-6544	Mudguard	Garde-boue	Schutzblech	Guardabarro
A65L/R ...	34 42-6548	Stay	Tringle	Strebe	Tirante
A50C, A65S/H ...	26 42-6560	Stay	Tringle	Strebe	Tirante
A65L/R ...	35 42-6564	Stay	Tringle	Strebe	Tirante
A50C, A65S/H ...	33 42-6566	Stay	Tringle	Strebe	Tirante
A50C, A65S/H, L/R ...	06 42-7029	Bolt	Boulon	Schraube	Tornillo
A65L/R ...	06 42-9169	Bolt	Boulon	Schraube	Tornillo
A50C, A65S/H, L/R ...	05 65-4784	Bolt	Boulon	Schraube	Tornillo
A65L/R ...	05 66-8347	Spacer	Entretoise	Distanzrohr	Distanciador
A65L/R ...	04 67-8313	Bolt	Boulon	Schraube	Tornillo

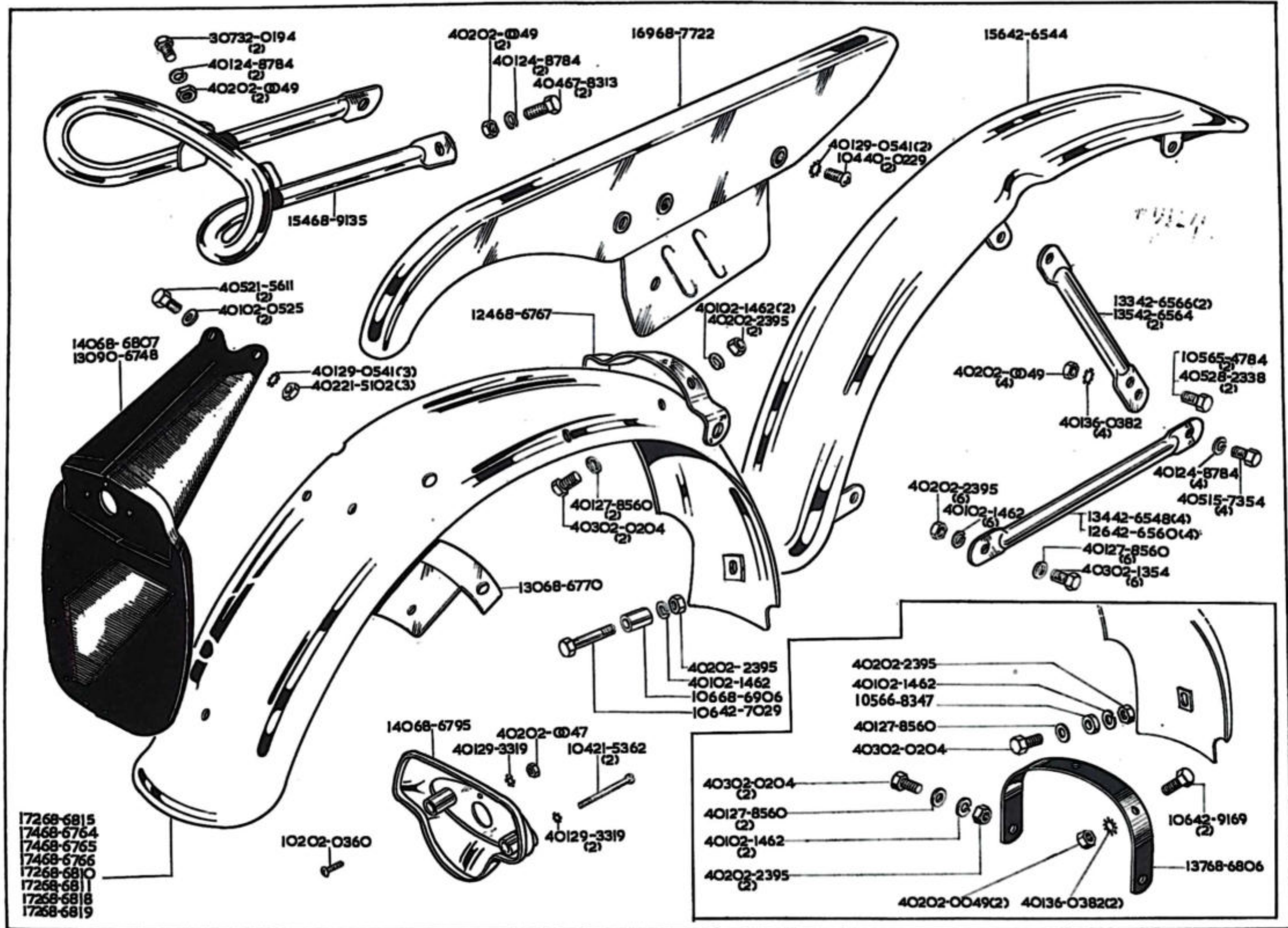

MUDGUARDS, GARDE-BOUE, SCHUTZBLECH, GUARDABARROS,

Model Modèle Typen Modelos	Spares No. No. de pièce Ersatzteil-Nr. No. de repuesto	Description	Designation	Beschreibung	Descripción
A50C, A65S/H, L/R ...	74 68-6764	Mudguard	Garde-boue	Schutzblech	Guardabarro
A65L/R	74 68-6765	Mudguard (West Coast)	Garde-boue	Schutzblech	Guardabarro
A50C, A65L/R	74 68-6766	Mudguard (East Coast)	Garde-boue	Schutzblech	Guardabarro
A50C, A65L/R, S/H ...	24 68-6767	Bracket	Bride	Verstrebung	Soporte
A50C, A65S/H, L/R ...	30 68-6770	Bracket	Bride	Verstrebung	Soporte
A65L/R, T/R, A50C ROAD MODEL	40 68-6795	Extension	Rallonge	Verlängerung	Extensión
MODEL					
A65L/R	37 68-6806	Bracket	Bride	Verstrebung	Soporte
A65L/R, A50C ROAD MODEL	†40 68-6807	Number Plate	Plaque de police	Nummernschild	Chapa de patente
A50C ROAD MODEL (EAST COAST).	†72 68-6810	Mudguard	Garde-boue	Schutzblech	Guardabarro
A50C ROAD MODEL(WEST COAST).	†72 68-6811	Mudguard	Garde-boue	Schutzblech	Guardabarro
A65S/H, A50C Comp. ...	†72 68-6815	Mudguard	Garde-boue	Schutzblech	Guardabarro
A65L/R (EAST COAST) ...	†72 68-6818	Mudguard	Garde-boue	Schutzblech	Guardabarro
A65L/R (WEST COAST) ...	†72 68-6819	Mudguard	Garde-boue	Schutzblech	Guardabarro
A50C, A65S/H, L/R ...	06 68-6906	Distance Piece	Entretoise	Distanzrohr	Distanciador
A50C, A65S/H, L/R ...	69 68-7722	Chainguard	Carter de chaîne	Kettenschutz	Guardacadena
A65L/R, A50C ROAD MODEL	54 68-9135	Handrail	Poignée	Griff	Puño
A50C, A65L/R	30 90-6748	Rear Number Plate	Plaque de police	Nummernschild	Chapa de patente
		†1965 Models	†1965 Modèles	†Typen 1965	†1965 Modelos

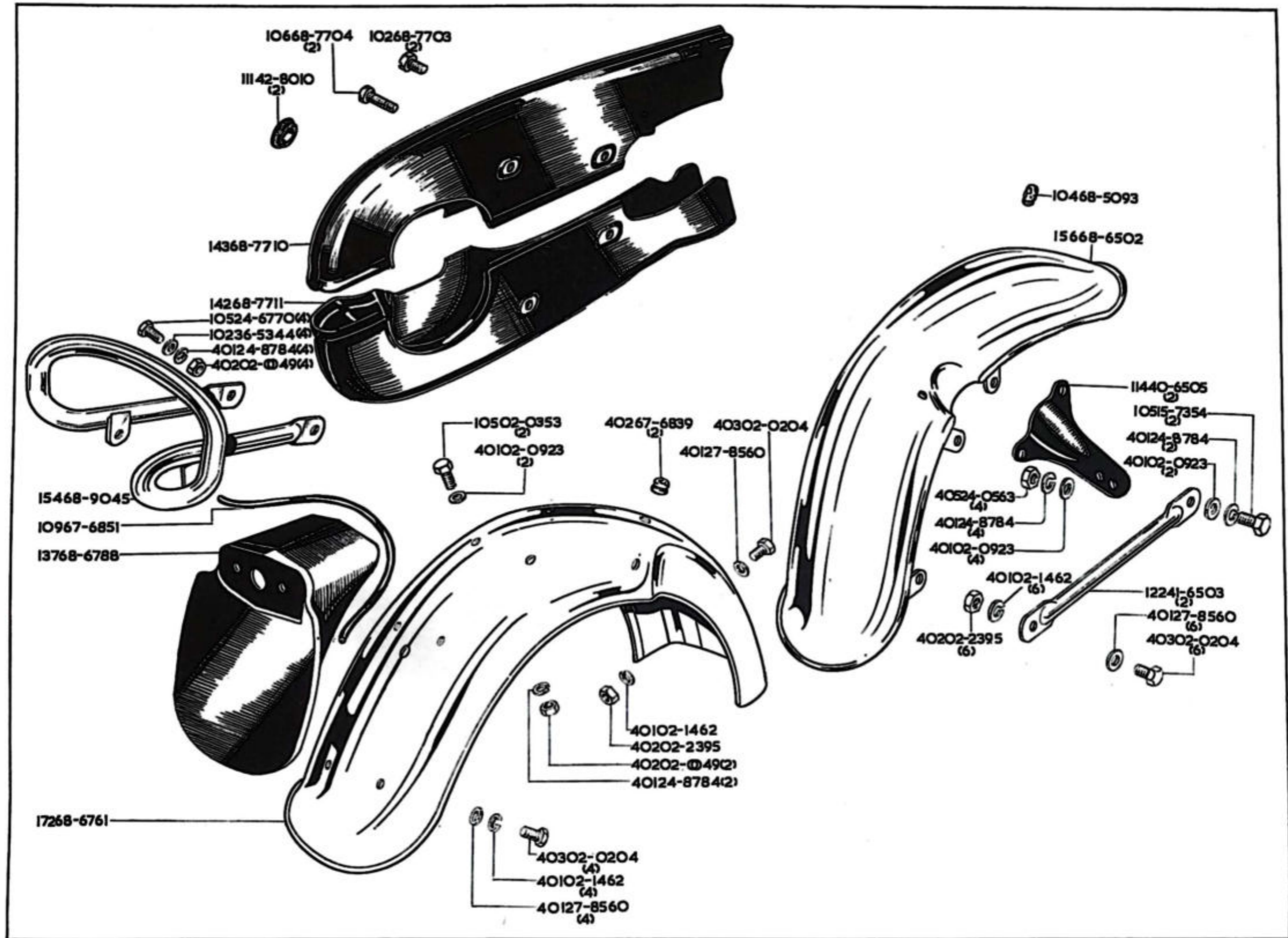

MUDGUARDS, GARDE-BOUE, SCHUTZBLECH, GUARDABARROS

Model Modèle Typen Modelos				Spare No. No. de pièce Ersatzteil-Nr. No. de repuesto	Description	Designation	Beschreibung	Descripción
A65T/R	02 02-0049	Nut	Écrou	Mutter	Tuerca
A65T/R	03 02-0204	Bolt	Boulon	Schraube	Tornillo
A65T/R	04 02-0353	Bolt	Boulon	Schraube	Tornillo
A65T/R	01 02-0923	Washer	Rondelle	Scheibe	Arandela
A65T/R	01 02-1462	Washer	Rondelle	Scheibe	Arandela
A65T/R	02 02-2395	Nut	Écrou	Mutter	Tuerca
A65T/R	05 15-7354	Bolt	Boulon	Schraube	Tornillo
A65T/R	05 24-0563	Nut	Écrou	Mutter	Tuerca
A65T/R	05 24-6770	Bolt	Boulon	Schraube	Tornillo
A65T/R	01 24-8784	Washer	Rondelle	Scheibe	Arandela
A65T/R	01 27-8560	Washer	Rondelle	Scheibe	Arandela
A65T/R	02 36-5344	Washer	Rondelle	Scheibe	Arandela
A65T/R	14 40-6505	Stay	Tringle	Strebe	Tirante
A65T/R	22 41-6503	Stay	Tringle	Strebe	Tirante
A65T/R	11 42-8010	Grommet	Rondelle capuchon	Tülle	Manguera
A65T/R	02 67-6839	Grommet	Rondelle capuchon	Tülle	Manguera
A65T/R	09 67-6851	Beading	Molure	Zierleiste	Moldura
A65T/R	04 68-5093	Grommet	Rondelle capuchon	Tülle	Manguera
A65T/R	56 68-6502	Front Mudguard	Garde-boue de roue avant	Vorderradschutzblech	Guardabarro delantera
A65T/R	72 68-6761	Rear Mudguard	Garde-boue de roue arrière	Hinterradschutzblech	Guardabarro trasera
A65T/R	37 68-6788	Number Plate	Plaque de police	Nummernschild	Chapa de patente
A65T/R	02 68-7703	Screw	Vis	Schraube	Tornillo
A65T/R	03 68-7704	Screw	Vis	Schraube	Tornillo
A65T/R	43 68-7710	Chaincase Top Section	Partie supérieur de la carter de chaîne.	Kettenkasten (Oberteil)	Parte superior del carter
A65T/R	42 68-7711	Chaincase Bottom Section	Partie inférieur de la carter de chaîne.	Kettenkasten (Unterteil)	Parte inferior del carter
A65T/R, L/R	54 68-9045	Handrail	Poignée	Griff	Puño

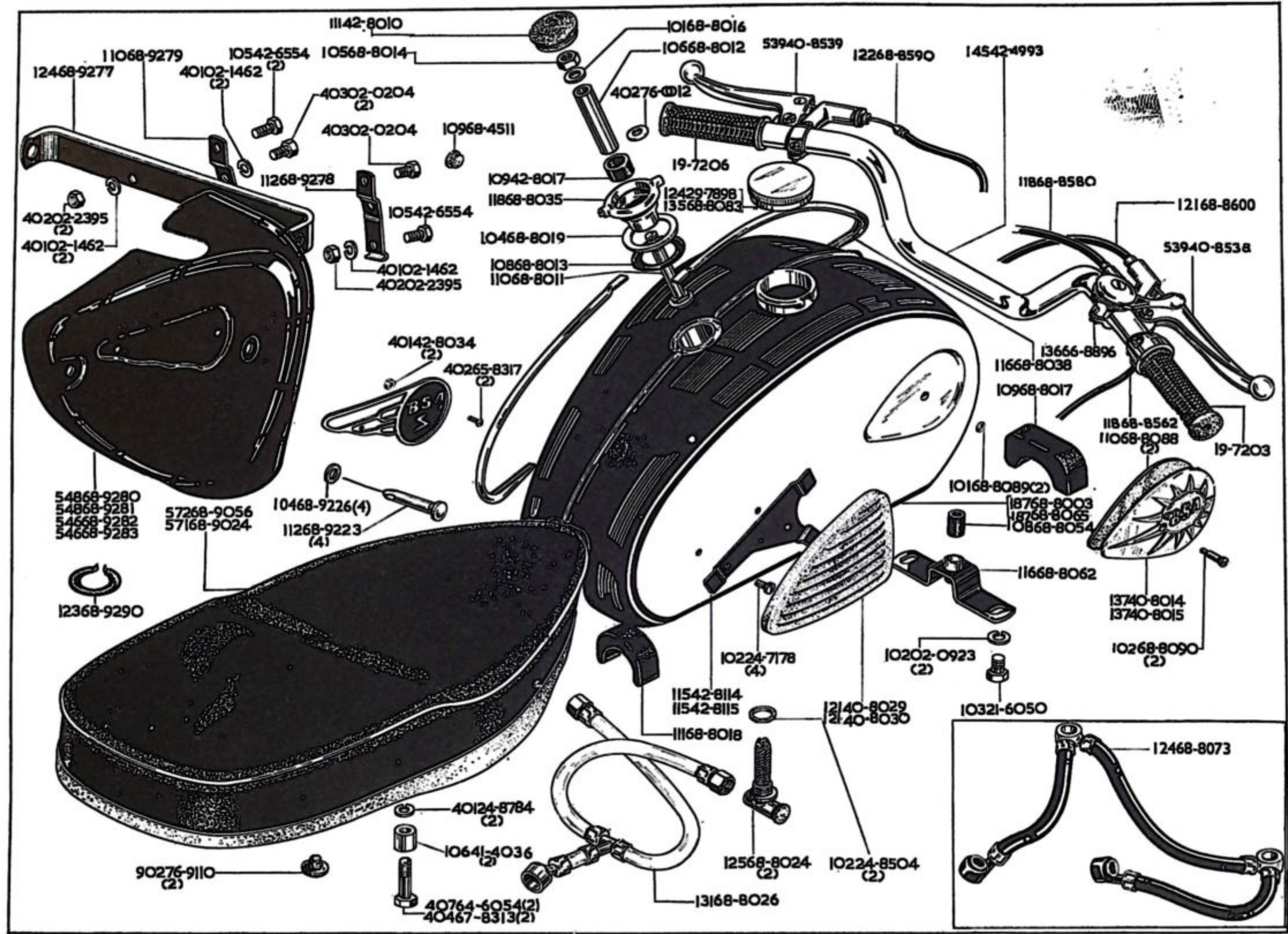

**DUAL SEAT, SELLE DOUBLE, DOPPELSITZ, ASIENTO DOBLE
PETROL TANK, RÉSERVOIR D'ESSENCE, BENZINTANK, DEPOSITO DE COMBUSTIBLE**

Model Modèle Typen Modelos	Spares No. No. de pièce Ersatzteil-Nr. No. de repuesto	Description	Designation	Beschreibung	Descripción
A50C, A65L/R, S/H	03 02-0204	Bolt	Boulon	Schraube	Tornillo
A65T/R	02 02-0923	Washer	Rondelle	Scheibe	Arandela
A50C, A65L/R, S/H	01 02-1462	Washer	Rondelle	Scheibe	Arandela
A50C, A65L/R, S/H	02 02-2395	Nut	Écrou	Mutter	Tuerca
	19-7203	Twist Grip	Poignée tournante de commande des gaz.	Gasdrehgriff	Puño girante de acelerador
	19-7206	Dummy Grip	Poignée en coutchouc	Gummifestgriff	Puño de goma
A65T/R	03 21-6050	Bolt	Boulon	Schraube	Tornillo
A65T/R	02 24-7178	Screw	Vis	Schraube	Tornillo
A65T/R	02 24-8504	Washer	Rondelle	Scheibe	Arandela
	01 24-8784	Spring Washer	Rondelle	Scheibe	Arandela
A65T/R	24 29-7898	Filler Cap	Bouchon de replissage	Verschlusskappe	Tapa
A65T/R	37 40-8014	Badge	Écusson	Typenzeichen	Placa
A65T/R	37 40-8015	Badge	Écusson	Typenzeichen	Placa
A65T/R	02 40-8016	Screw	Vis	Schraube	Tornillo
A65T/R	21 40-8029	Knee Grip	Tampon caoutchouc	Gummiauflage	Cojin de goma
A65T/R	21 40-8030	Knee Grip	Tampon caoutchouc	Gummiauflage	Cojin de goma
A65T/R	03 40-8045	Washer	Rondelle	Scheibe	Arandela
A50C	39 40-8538	Brake Lever	Levier de frein	Bremshebel	Palanca de freno
A50C	39 40-8539	Clutch Lever	Levier de embrayage	Kupplungshebel	Palanca de embrague
A50C, A65S/H, L/R	06 41-4036	Distance Piece	Entretoise	Distanzrohr	Distanciadador
A65S/H, A50C	†45 42-4993	Handlebar	Guidon	Lenker	Manillar
A50C, A65L/R, S/H	05 42-6554	Bolt	Boulon	Schraube	Tornillo
A65T/R	11 42-8010	Grommet	Rondelle capuchon	Tülle	Manguera
A65T/R	09 42-8017	Fixing Rubber	Tampon	Gummiauflage	Cojin de goma
A50C, A65L/R, S/H	01 42-8034	Nut	Écrou	Mutter	Tuerca
A65T/R	15 42-8114	Bracket	Support	Verstrebung	Soporte
A65T/R	15 42-8115	Bracket	Support	Verstrebung	Soporte
A50C, A65S/H, L/R	07 64-6054	Bolt	Boulon	Schraube	Tornillo
A50C, A65L/R, S/H	02 65-8317	Screw	Vis	Schraube	Tornillo
A50C	36 66-8896	Air Control Lever	Levier pour la manette d'air	Lufthebel	Palanca para la manecilla de aire
A65T/R	04 67-8313	Bolt	Boulon	Schraube	Tornillo
A50C, A65L/R, S/H	09 68-4511	Rubber	Caoutchouc	Gummi	Goma
A65T/R	87 68-8003	Petrol Tank	Réservoir de essence	Benzintank	Deposito de combustible
A65T/R	10 68-8011	Bolt	Boulon	Schraube	Tornillo
A65T/R	06 68-8012	Distance Tube	Entretoise	Distanzrohr	Distanciadador
A65T/R	08 68-8013	"O" Ring	Bague "O"	"O" Ring	Anillo "O"
A65T/R	05 68-8014	Nut	Écrou	Mutter	Tuerca
A65T/R	01 68-8016	Washer	Rondelle	Scheibe	Arandela
A65T/R	09 68-8017	Rubber Moulding	Caoutchouc moule	Profilgummi	Profil de goma
A65T/R	11 68-8018	Rubber Moulding	Caoutchouc moule	Profilgummi	Profil de goma
A65T/R	04 68-8019	Mounting Washer	Rondelle	Scheibe	Arandela
A65T/R	25 68-8024	Petrol Tap	Robinet à essence	Benzinhahn	Grifo de benzina
A65T/R	31 68-8026	Petrol Pipe	Tuyauterie d'essence	Benzinleitung	Tubo de benzina
A65T/R	18 68-8035	Beading Holder	Bride pour molure	Lasche für Zierleiste	Brida para moldura
A65T/R	16 68-8038	Beading	Molure	Zierleiste	Moldura
A65T/R	16 68-8039	Beading	Molure	Zierleiste	Moldura

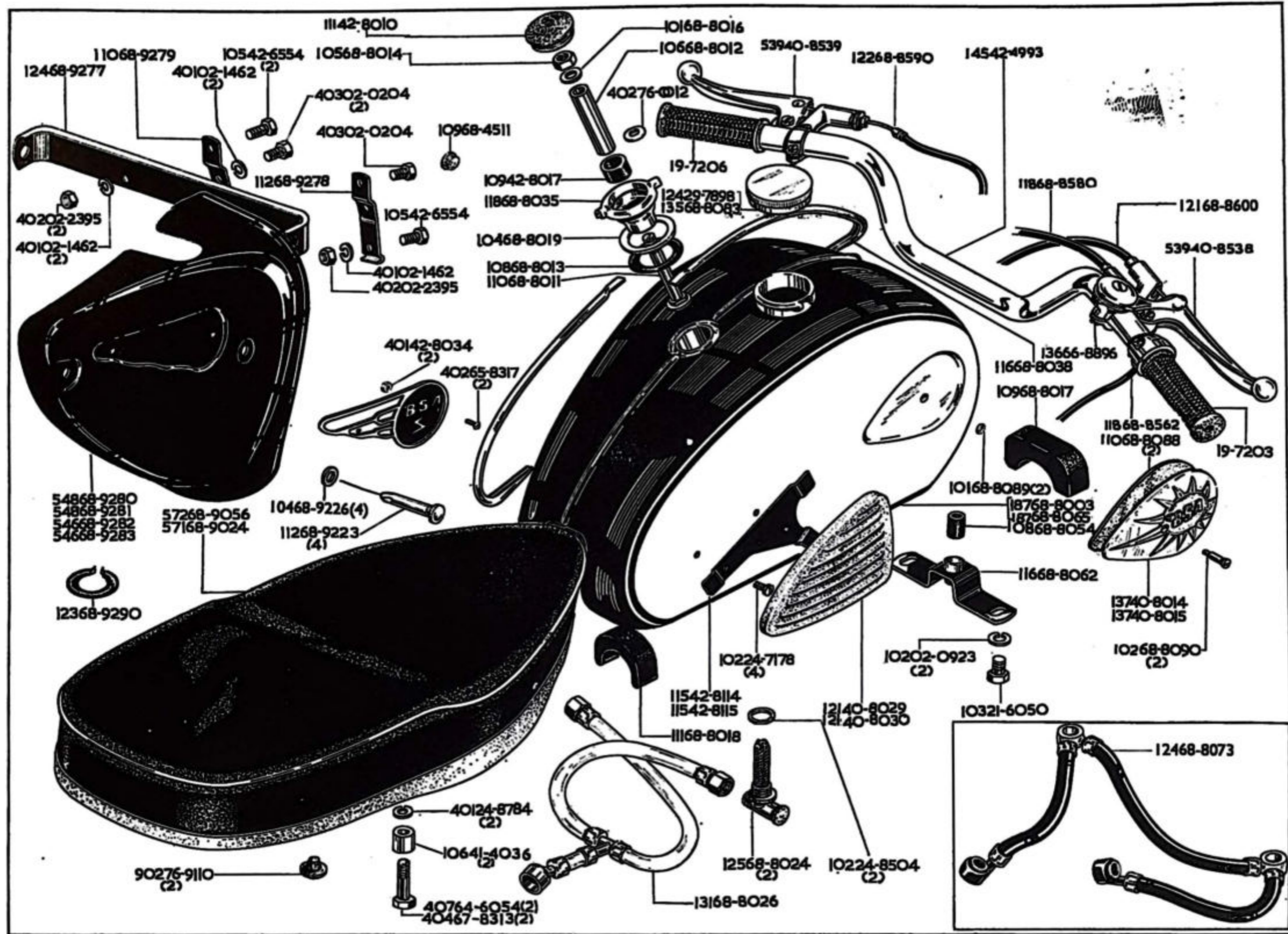

**DUAL SEAT, SELLE DOUBLE, DOPPELSITZ, ASIENTO DOBLE
PETROL TANK, RÉSERVOIR D'ESSENCE, BENZINTANK, DEPOSITO DE COMBUSTIBLE**

Model Modèle Typen Modelos	Spares No. No. de pièce Ersatzteil-Nr. No. de repuesto	Description	Designation	Beschreibung	Descripción
A65T/R	08 68-8054	Rubber Bush	Douille caoutchouc	Gummimuffe	Manguita de goma
A65T/R	16 68-8062	Bracket	Support	Verstrebung	Soporte
A65L/R	35 68-8083	Filler Cap	Bouchon de remplissage	Verschlusskappe	Tapa
A65L/R	87 68-8065	Petrol Tank	Réservoir de essence	Benzintank	Deposito de combustible
A50C, A65L/R, S/H	24 68-8073	Petrol Pipe	Tuyauterie de essence	Benzinleitung	Tubo de benzina
A65L/R, T/R	10 68-8088	Packing Pad	Tampon	Auflage	Cojin
A65L/R, T/R	01 68-8089	Washer	Rondelle	Scheibe	Arandela
A65L/R, T/R	02 68-8090	Screw	Vis	Schraube	Tornillo
A50C, A65L/R, S/H	18 68-8562	Throttle Cable	Commande des gaz	Seilzug für Vergaser	Cable Bowden para acelerador
A50C, A65L/R, S/H	18 68-8580	Air Cable	Câble pour la manette d'air	Seilzug für Luft	Cable para la manecilla de aire
A65S/H, A50C	22 68-8590	Clutch Cable	Cable de commande de l'embrayage.	Kupplungskabel	Cable Bowden para embrague
A50C, A65S/H	21 68-8600	Brake Cable	Cable de commande du frein avant.	Vorderradbremskabel	Cable Bowden para freno delantera.
A65T/R	71 68-9024	Twin Seat	Selle double	Doppelsitz	Asiento doble
A50C, A65S/H, L/R	72 68-9056	Twin Seat	Selle double	Doppelsitz	Asiento doble
A50C, A65L/R, S/H	11 68-9223	Stud	Goujon	Stehbolzen	Esparago
A50C, A65 S/H, L/H	04 68-9226	Rubber	Caoutchouc	Gummi	Goma
A50C, A65L/R, S/H	22 68-9235	Badge (left-hand)	Écusson (gauche)	Firmenzeichen (links)	Rotulo (izquierdo)
A50C, A65L/R, S/H	22 68-9236	Badge (right-hand)	Écusson (droite)	Firmenzeichen (rechts)	Rotulo (derecho)
A50C, A65L/R, S/H	12 68-9278	Support (left-hand)	Support (gauche)	Verstrebung (links)	Soporte (izquierdo)
A50C, A65L/R, S/H	10 68-9279	Support (right-hand)	Support (droite)	Verstrebung (rechts)	Soporte (derecho)
A50C, A65L/R, S/H	24 68-9277	Bracket	Support	Verstrebung	Soporte
A65L/R	48 68-9280	Sidecover (left-hand)	Panneau de lateral (gauche)	Seitenblech (links)	Panel de lado (izquierdo)
A65L/R	48 68-9281	Sidecover (right-hand)	Panneau de lateral (rechts)	Seitenblech (droite)	Panel de lado (derecho)
A50C, A65S/H	46 68-9282	Sidecover (left-hand)	Panneau de lateral (gauche)	Seitenblech (links)	Panel de lado (izquierdo)
A50C, A65S/H	46 68-9283	Sidecover (right-hand)	Panneau de lateral (droite)	Seitenblech (rechts)	Panel de lado (derecho)
A50C, A65L/R, S/H	23 68-9290	Rubber Buffer	Butée caoutchouc	Gummistopfen	Tope de goma
A50C, A65S/H, L/R	72 68-9056	Twin Seat	Selle Double	Doppelsitz	Asiento doble
A65T/R	02 76-0012	Washer	Rondelle	Scheibe	Arandela
	02 76-9110	Grommet	Rondelle capuchon	Tülle	Manguera
		†1964 models.	†1964 modèles.	†Typen 1964.	†Modelos 1964.

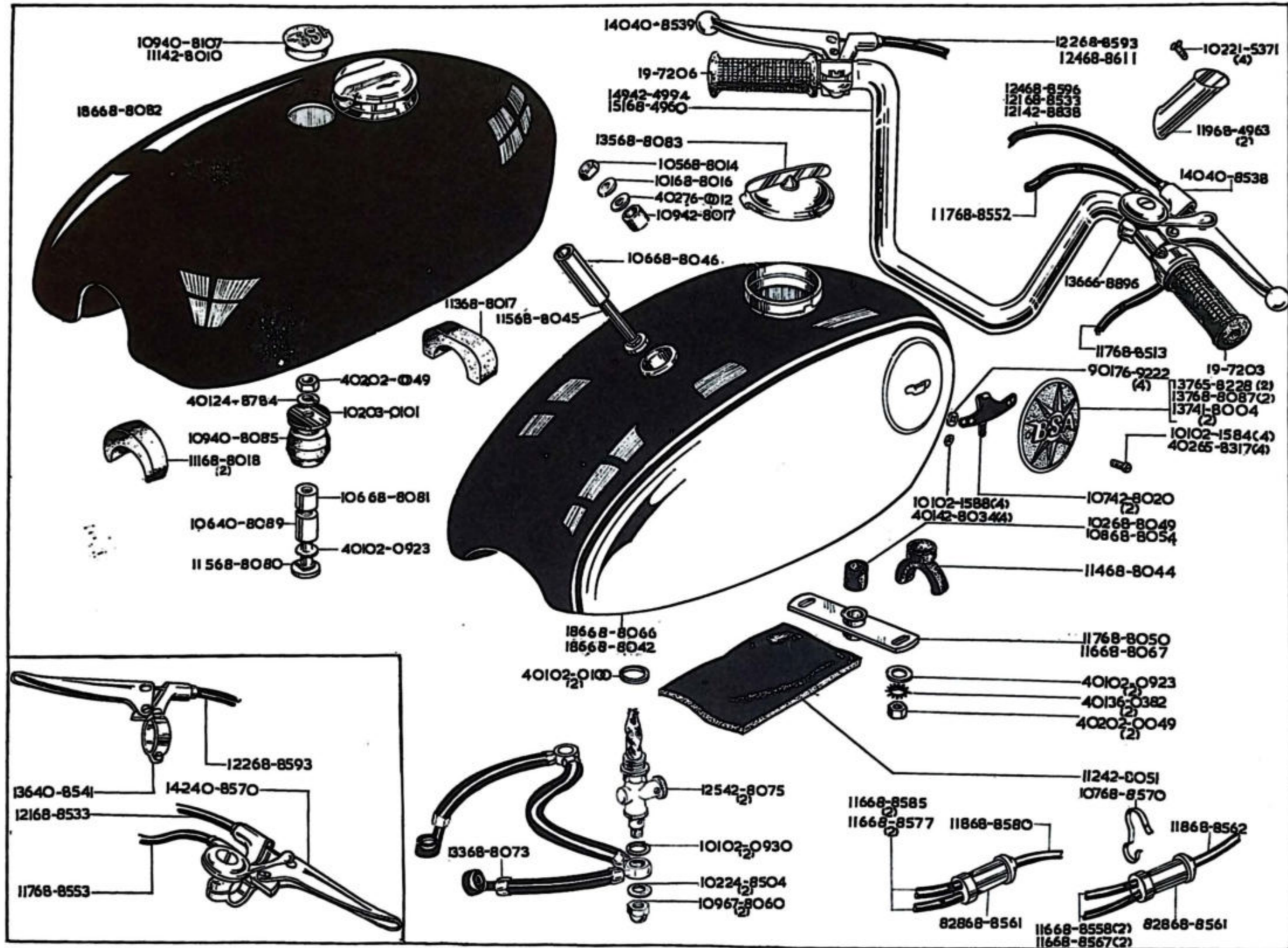

DUAL SEAT, SELLE DOUBLE, DOPPELSITZ, ASIENTO DOBLE PETROL TANK, RÉSERVOIR D'ESSENCE, BENZINTANK, DEPOSITO DE COMBUSTIBLE

Model Modèle Typen Modelos	Spare No. No. de pièce Ersatzteil-Nr. No. de repuesto	Description	Designation	Beschreibung	Descripción
A65L/R, S/H, T/R, A50C	02 02-0049	Nut	Écrou	Mutter	Tuerca
A65L/R, A50C ...	01 02-0100	Washer	Rondelle	Scheibe	Arandela
A65L/R, T/R, S/H, A50C	01 02-0923	Washer	Rondelle	Scheibe	Arandela
A65L/R, A50C ...	01 02-0930	Washer	Rondelle	Scheibe	Arandela
A50C, A65L/R ...	01 02-1584	Screw	Vis	Schraube	Tornillo
A50C, A65L/R ...	01 02-1588	Nut	Écrou	Mutter	Tuerca
A65S/H ...	02 03-0101	Washer	Rondelle	Scheibe	Arandela
A65L/R, S/H, A50C ...	19-7086	Junction Box			
A65L/R, A50C, A65T/R	19-7203	Twist Grip	Poignée tournante de commande des gaz.	Drehgriff	Puño girante de acelerador
A65L/R, A50C, A65T/R	19-7206	Dummy Grip	Poignée en coutchouc	Gummifestgriff	Puño fijo de goma
A65L/R, T/R, S/H, A50C	02 21-5371	Screw	Vis	Schraube	Tornillo
A65L/R, A50C ...	02 24-8504	Washer	Rondelle	Scheibe	Arandela
A65S/H ...	01 24-8784	Washer	Rondelle	Scheibe	Arandela
A65L/R, A50C, A65T/R	01 36-0382	Washer	Rondelle	Scheibe	Arandela
A65S/H ...	09 40-8085	Rubber Buffer	Butée caoutchouc	Gummistopfen	Tope de goma
A65S/H ...	06 40-8089	Distance Tube	Entretoise	Distanzrohr	Distanciador
A65S/H ...	09 40-8107	Grommet	Rondelle capuchon	Tülle	Manguera
A65L/R, A50C ...	40 40-8538	Brake Lever	Levier de frein	Bremshebel	Palanca de freno
A65L/R, A50C, A65S/H	40 40-8539	Clutch Lever	Levier d'embrayage	Kupplungshebel	Palanca del embrague
A65T/R ...	36 40-8541	Clutch Lever	Levier d'embrayage	Kupplungshebel	Palanca del embrague
A65T/R ...	42 40-8570	Brake and Air Control	Levier de came de frein et d'air	Bremshebel und Lufthebel	Palanca de freno y de aire
A65T/R ...	37 41-8004	Badge	Écusson	Firmenzeichen	Rotulo
A65S/H, A50C ...	49 42-4994	Handlebar	Guidon	Lenker	Manillar
A65L/R, A65T/R, A50C	11 42-8010	Grommet	Rondelle capuchon	Tülle	Manguera
A65L/R, A50C ...	09 42-8017	Rubber Sleeve	Douille caoutchouc	Gummimuffe	Manguita de goma
A65L/R, A50C, A65T/R	07 42-8020	Clip	Bride	Klammer	Grapa
A65L/R, A50C ...	25 42-8075	Petrol Tap	Robinet à essence	Benzinhahn	Grifo de benzina
A65L/R, A50C, A65S/H	21 42-8838	Brake Cable	Câble de commande du frein avant.	Vorderradbremskabel	Cable Bowden para freno delantera.
A65T/R ...	02 65-8317	Screw	Vis	Schraube	Tornillo
A65L/R, A50C ...	36 66-8896	Air Control Lever	Levier pour la manette d'air	Lufthebel	Palanca para la manecilla de aire
A65L/R, A50C ...	09 67-8060	Nut	Écrou	Mutter	Tuerca
A65T/R, L/R, A50C ROAD	51 68-4960	Handlebar	Guidon	Lenker	Manillar
MODEL.					
A65L/R, T/R, S/H, A50C	19 68-4963	Cable Guide	Guide	Führung	Guia
A65L/R, A50C ...	05 68-8014	Nut	Écrou	Mutter	Tuerca
A65L/R, A50C ...	01 68-8016	Washer	Rondelle	Scheibe	Arandela
A65S/H ...	13 68-8017	Rubber Buffer	Butée caoutchouc	Gummistopfen	Tope de goma
A65S/H ...	11 68-8018	Rubber Buffer	Butée caoutchouc	Gummistopfen	Tope de goma
A65T/R ...	86 68-8042	Petrol Tank (2 gallon)	Réservoir d'essence	Kraftstoffbehälter	Deposito de combustible
A65L/R, A50C, A65T/R	14 68-8044	Rubber Moulding	Caoutchouc moule	Profingummi	Perfil de goma
A65L/R, A50C, A65T/R	15 68-8045	Bolt	Boulon	Schraube	Tornillo
A65L/R, A50C, A65T/R	06 68-8046	Distance Tube	Entretoise	Distanzrohr	Distanciador
A65T/R ...	02 68-8049	Rubber Sleeve	Douille caoutchouc	Gummimuffe	Manguita de goma
A65T/R ...	17 68-8050	Bracket	Support	Verstrebung	Soporte
A65L/R, A50C, A65T/R	08 68-8054	Rubber Sleeve	Douille caoutchouc	Gummimuffe	Manguita de goma

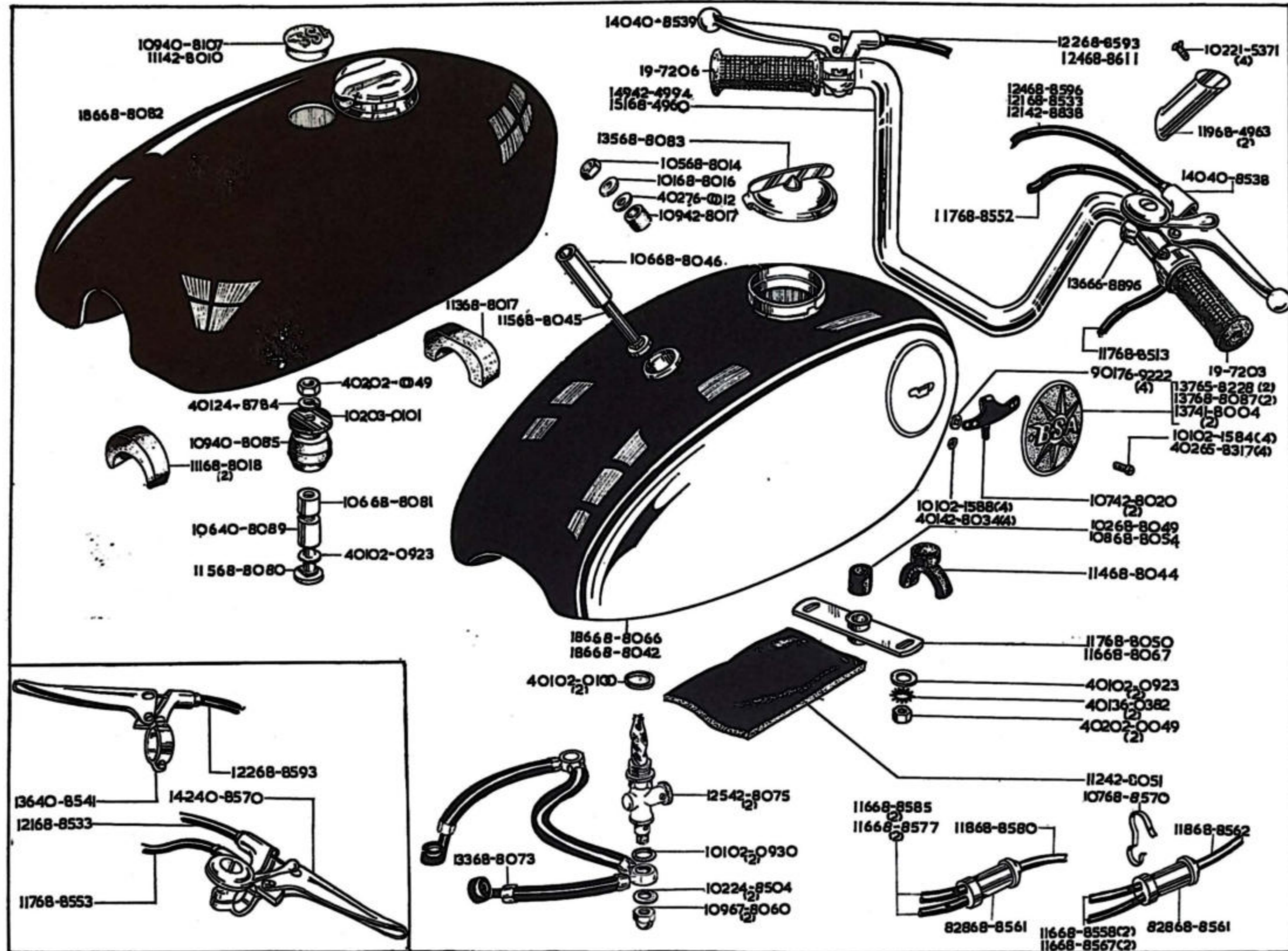

**DUAL SEAT, SELLE DOUBLE, DOPPELSITZ, ASIENTO DOBLE
PETROL TANK, RÉSERVOIR D'ESSENCE, BENZINTANK, DEPOSITO DE COMBUSTIBLE**

Model Modèle Typen Modelos	Spares No. No. de pièce Ersatzteil-Nr. No. de repuesto	Description	Designation	Beschreibung	Descripción
A65L/R, A50C	86 68-8066	Petrol Tank (2 gallons)	Réservoir d'essence	Kraftstoffbehälter	Deposito de combustible
A65T/R, A50C, A65T/R	16 68-8067	Bracket	Support	Verstrebung	Soporte
A65L/R, A50C, A65S/H	33 68-8073	Petrol Pipe	Tuyauterie d'essence	Benzinleitung	Tubo de benzina
A65S/H	15 68-8080	Bolt	Boulon	Schraube	Tornillo
A65S/H	06 68-8081	Distance Tube	Entretoise	Distanzrohr	Distanciador
A65L/R, A50C, A65T/R	09 42-8049	Rubber Mat	Recouvrement caoutchouc	Gummibelag	Estera de goma
A65S/H	86 68-8082	Petrol Tank (2 gallons —fibre glass).	Réservoir d'essence	Kraftstoffbehälter	Deposito de combustible
A65L/R, A50C	35 68-8083	Filler Cap	Bouchon de remplissage	Verschlusskappe	Tapa
A50C	37 68-8087	Badge	Écusson	Firmenzeichen	Rotulo
A65L/R	37 65-8228	Badge	Écusson	Firmenzeichen	Rotulo
A65T/R	17 68-8513	Throttle Cable	Commande de gaz	Gaszug	Cable Bowden para acelerador
A65T/R	21 68-8533	Brake Cable	Cable de commande du frein avant.	Vorderradbremskabel	Cable Bowden para freno delantera.
A65T/R	17 68-8552	Air Cable	Câble pour la manette d'air	Seilzug für Luft	Cable para la manecilla de aire
A65L/R	16 68-8558	Throttle Cable (short)	Commande de gaz (court)	Gaszug (kurz)	Cable Bowden para acelerador (corto).
A65L/R, A50C	18 68-8562	Throttle Cable (long)	Commande de gaz (longue)	Gaszug (lang)	Cable Bowden para acelerador (largo).
A50C	16 68-8567	Throttle Cable (short)	Commande de gaz (courte)	Gaszug (kurz)	Cable Bowden para acelerador (corto).
A65L/R, A50C	07 68-8570	Junction Box Clip	Bride	Klammer	Grapa
A65L/R, S/H	16 68-8577	Air Cable (short)	Cable pour la manette d'air (courte).	Seilzug für Luft (kurz)	Cable para la manecilla de aire (corto).
A65L/R, S/H, A50C	18 68-8580	Air Cable (long)	Câble pour la manette d'air (courte).	Seilzug für Luft (kurz)	Cable para la manecilla de aire (corto).
A50C	16 68-8585	Air Cable (short)	Câble pour la manette d'air (courte).	Seilzug für Luft (kurz)	Cable para la manecilla de aire (corto).
A65L/R, T/R, S/H, A50C	22 68-8593	Clutch Cable	Câble de commande de l'embrayage.	Kupplungskabel	Cabel Bowden para embrague
A65T/R	†24 68-8596	Brake Cable	Câble de commande du frein	Vorderradbremskabel	Cable Bowden para freno
	†24 68-8611	Clutch Cable	Câble de commande de l'embrayage.	Kupplungskabel	Cable Bowden para embrague
A65L/R, A50C	02 76-0012	Washer	Rondelle	Scheibe	Arandela
A65T/R	01 76-9222	Washer	Rondelle	Scheibe	Arandela

†1965 models.

†1965 modèles.

†Typen 1965.

†Modelos 1965.

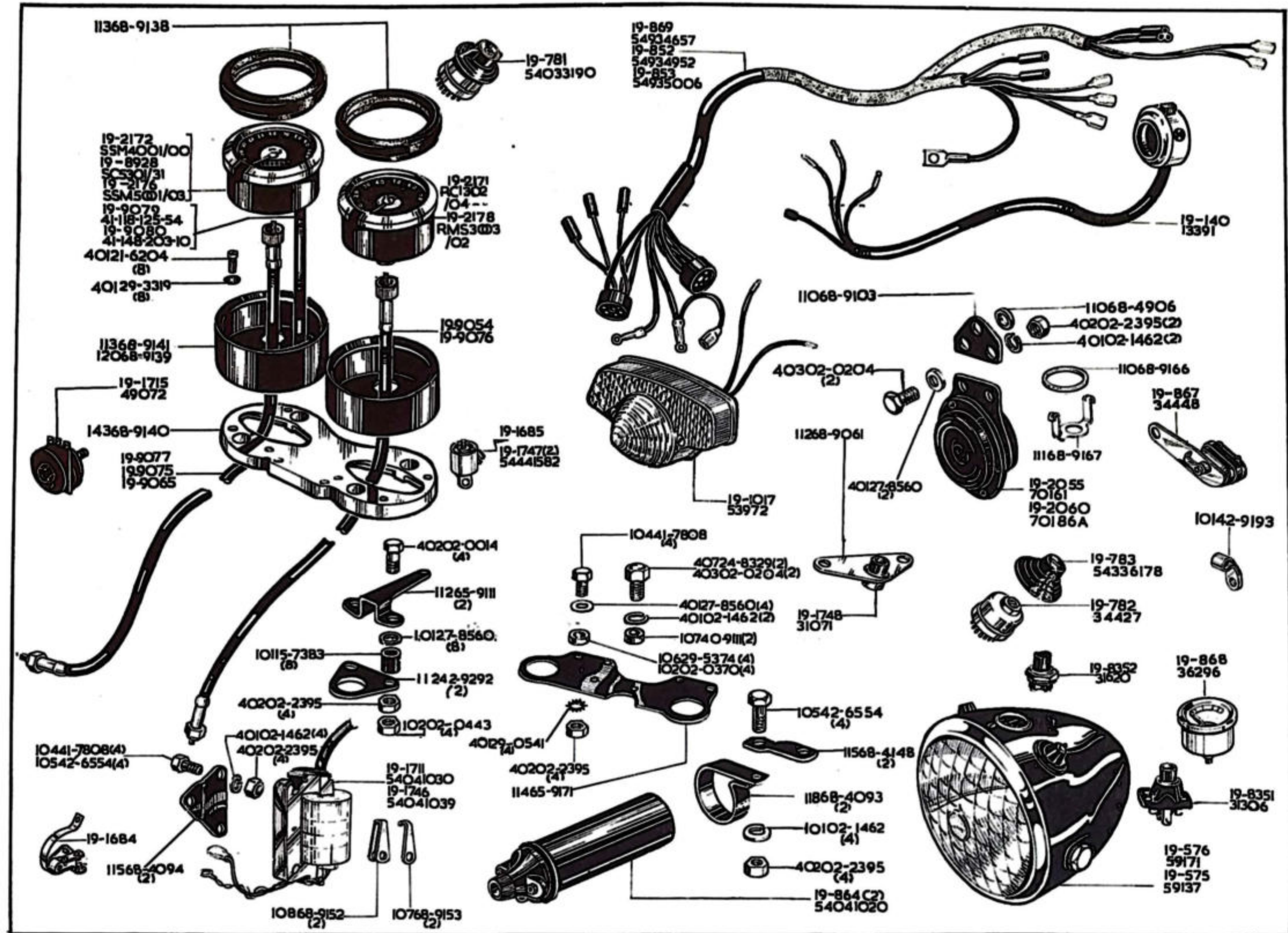

ELECTRICAL EQUIPMENT, EQUIPEMENT ELECTRIQUE, ELEKTR. AUSRÜSTUNG, EQUIPO ELECTRICO

Model Modèle Typen Modelos	Spares No. No. de pièce Ersatzteil-Nr. No. de repuesto	Description	Designation	Beschreibung	Descripción
A65T/R	*02 02-0014	Bolt	Boulon	Schraube	Tornillo
	03 02-0204	Bolt	Boulon	Schraube	Tornillo
A50C, A65S/H	02 02-0370	Distance Piece	Entretoise	Distanzrohr	Distanciador
A65T/R	*02 02-0443	Locknut	Écrou de blocage	Gegenmutter	Tuerca de fijación
	01 02-1462	Washer	Rondelle	Scheibe	Arandela
	02 02-2395	Nut	Écrou	Mutter	Tuerca
A65T/R	*01 15-7383	Mounting Washer	Bague caoutchouc	Gummiring	Anillo de goma
A65L/R, T/R, A50C ROAD MODEL.	19-0140	Ducon Switch	Avertisseur et inverseur code	Hupe und Ablenschalter	Bocina y conmutador de cruce
A50C	19-0564	Headlamp complete	Phare complet	Scheinwerfer komplett	Faro completo
A65L/R, T/R	19-0573	Headlamp complete	Phare complet	Scheinwerfer komplett	Faro completo
A65L/R, T/R	†19-0575	Headlamp	Phare	Scheinwerfer	Faro
A65T/R, A50C ROAD MODEL	19-0576	Headlamp	Phare	Scheinwerfer	Faro
A65L/R, T/R	19-0781	Light Switch	Interrupteur pour phare	Schalter für Scheinwerfer	Interruptor para faro
A65L/R, T/R	19-0782	Ignition Switch	Commutateur d'allumage	Zündschalter	Interruptor de encendido
A65L/R, T/R	19-0783	Shroud	Fourreau	Hülse	Manguito
A65S/H, A50C ROAD MODEL	19-0852	Harness	Faisceau de câbles	Kabelstrang	Juego de cables
A50C, A65S/H	19-0853	Harness	Faisceau de câbles	Kabelstrang	Juego de cables
A65L/R, T/R, A50C ROAD MODEL.	19-0864	Coil	Bobine	Spule	Bobina
A65L/R, T/R, A50C ROAD MODEL.	19-0867	Stop Lamp Switch	Commutateur de lampe de stop.	Stoplichtschalter	Interruptor para luz stop
A65L/R	19-0868	Ammeter	Ampèremètre	Amperemeter	Amperimetro
A65L/R, T/R, A50C ROAD MODEL.	19-0869	Harness	Faisceau de câbles	Kabelstrang	Juego de cables
A65L/R, T/R	19-1017	Stop Tail Lamp	Feu rouge arrière	Schlusslicht	Luz rojo trasera
A65L/R, T/R, A50C ROAD MODEL.	19-1670	Battery	Batterie	Batterie	Bateria
A65L/R, T/R	19-1684	Points			
A50C, A65S/H	19-1685	Condenser	Condensateur	Kondensator	Condensador
A65L/R, T/R, A50C ROAD MODEL.	19-1711	Coil (right-hand)	Bobine (droite)	Spule (rechts)	Bobina (derecho)
A50C, A65S/H	19-1715	Rectifier	Redresseur	Gleichrichter	Rectificador
A50C, A65S/H	19-1746	Coil (left-hand)	Bobine (gauche)	Spule (links)	Bobina (izquierdo)
A50C	19-1747	Condensers	Condensateur	Kondensator	Condensador
A50C, A65S/H	19-1748	Cut-out Button	Disjoncteur	Kurzschluss	
A50C	19-2046	Horn	Avertisseur	Hupe	Bocina
A65L/R, T/R	19-2055	Horn	Avertisseur	Hupe	Bocina
A50C	19-2056	Horn Push	Bouton d'avertisseur	Hupenknope	Botón de bocina
A65L/R, T/R	† 19-2060	Horn	Avertisseur	Hupe	Bocina
A65T/R	* 19-2171	Rev Counter Head	Compte-tours	Drehzahlmesser	Contador de vueltas
A50C ROAD MODEL	19-2172	Speedo Head	Compteur de vitesses	Tachometer	Velocímetro
A65T/R	† 19-2172	Speedo Head	Compteur de vitesses	Tachometer	Velocímetro
	19-2176	Speedo Head	Compteur de vitesses	Tachometer	Velocímetro
A50C, A65L/R, T/R	19-2178	Revo Counter Head	Compte-tours	Drehzahlmesser	Contador de vueltas
A50C	19-8351	Light Switch	Interrupteur pour phare	Schalter für Scheinwerfer	Interruptor para faro
A50C	19-8352	Dipper Switch	Inverseur code phare	Ablenschalter	Conmutador de cruce
A65T/R	* 19-8928	Speedo Head	Compteur de vitesses	Tachometer	Velocímetro
A65T/R	* 19-9054	Rev Counter Cable	Câble de compteur	Tachometerkabel	Arbol de transmisión del velocímetro.

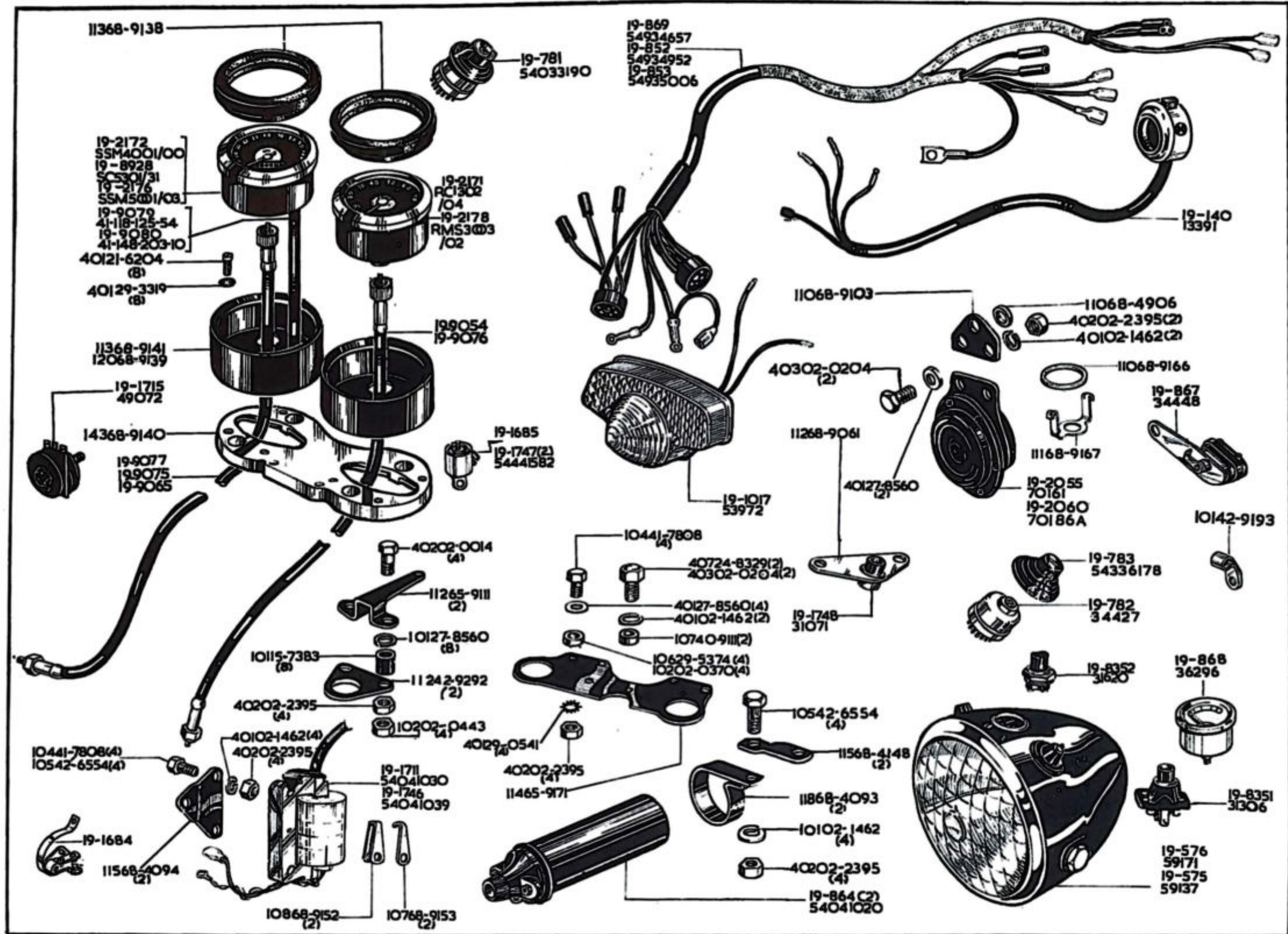

ELECTRICAL EQUIPMENT, EQUIPEMENT ELECTRIQUE, ELEKTR. AUSRÜSTUNG, EQUIPO ELECTRICO

Model Modèle Typen Modelos	Spares No. No. de pièce Ersatzteil-Nr. No. de repuesto	Description	Designation	Beschreibung	Descripción
A65T/R	* 19-9065	Speedometer Cable	Câble de compteur	Tachometerkabel	Arbol de transmisión del velocímetro.
A65L/R, T/R	19-9075	Speedometer Cable	Câble de compteur	Tachometerkabel	Arbol de transmisión del velocímetro.
A50C, A65L/R, T/R	19-9076	Rev Counter Cable	Câble de compteur	Tachometerkabel	Arbol de transmisión del velocímetro.
A50C, A65S/H, T/R	19-9077	Speedometer Cable	Câble de compteur	Tachometerkabel	Arbol de transmisión del velocímetro.
	19-9079	Trip Shaft	Arbre pour compteur de voyage.	Shaft für Tachometerreizezähler	Arbol portmetro del trayecto
A65T/R	‡ 19-9080	Trip Shaft	Arbre pour compteur de voyage.	Shaft für Tachometerreizezähler	Arbol portmetro del trayecto
A65L/R, T/R	01 21-6204	Screw	Vis	Schraube	Tornillo
A50C, A65S/H	07 24-7343	Bolt	Boulon	Schraube	Tornillo
A65S/H	07 24-8329	Bolt	Boulon	Schraube	Tornillo
A50C, A65S/H, T/R	01 27-8560	Washer	Rondelle	Scheibe	Arandela
A50C	01 29-0541	Washer	Rondelle	Scheibe	Arandela
A65L/R, T/R	01 29-3319	Washer	Rondelle	Scheibe	Arandela
A50C	06 29-5374	Distance Piece	Entretoise	Distanzrohr	Distanciador
A65S/H	07 40-9111	Distance Piece	Entretoise	Distanzrohr	Distanciador
A50C, A65S/H	04 41-7808	Bolt	Boulon	Schraube	Tornillo
A50C, A65L/R, T/R	05 42-6554	Bolt	Boulon	Schraube	Tornillo
A50C, A65S/H	06 42-8098	Distance Piece	Entretoise	Distanzrohr	Distanciador
A65T/R, A50C ROAD MODEL	01 42-9193	Cable Clip	Attache pour câble	Kabelklemme	Abrazadera de cable
A65T/R	*12 42-9292	Bracket	Bride	Verstrebung	Soporte
A65T/R	*12 65-9111	Bracket	Bride	Verstrebung	Soporte
A50C	14 65-9171	Bracket	Bride	Verstrebung	Soporte
	05 66-8340	Clip	Bride	Klammer	Grapa
A50C, A65S/H	05 66-8347	Distance Piece	Entretoise	Distanzrohr	Distanciador
A65L/R, T/R, A50C ROAD MODEL	18 68-4093	Clip	Bride	Klammer	Grapa
A50C, A65S/H	15 68-4094	Bracket	Bride	Verstrebung	Soporte
A65L/R	15 68-4148	Bracket	Bride	Verstrebung	Soporte
A65L/R, T/R, A50C ROAD MODEL	10 68-4906	Distance Piece	Entretoise	Distanzrohr	Distanciador
A50C, A65S/H	12 68-9061	Bracket	Bride	Verstrebung	Soporte
A65L/R, T/R, A50C ROAD MODEL	10 68-9103	Bracket	Bride	Verstrebung	Soporte
	13 68-9138	Mounting Rubber	Bague caoutchouc	Gummiring	Anillo de goma
A50C, A65S/H	20 68-9139	Speedo Holder	Cuvette	Schale	Copa
A65L/R, T/R	43 68-9140	Bracket	Bride	Verstrebung	Soporte
A65L/R, T/R	13 68-9141	Cup	Cuvette	Schale	Copa
A50C, A65S/H	08 68-9152	Coil Retainer	Arrêttoir	Sicherung	Freno
A50C, A65S/H	07 68-9153	Clip	Bride	Klammer	Grapa
	09 68-9163	Vent Pipes	Tuyeau de ventilateur d'accumulateur.	Batterie-Entlüftungsrohr	Tubo del ventilación de la acumuladorra.
A65T/R	11 68-9167	Bracket	Bride	Verstrebung	Soporte

*Fitted up to Engine No. A65C — 367.

†1965 models.

‡When Speedometer and Rev Counter are fitted.

*Monté avant moteur numéro A65C — 367.

†1965 modèles.

‡Equipé d'un compteur de vitesses et un compte tours.

*Montiert bis Motornummer A65C — 367.

†Typen 1965.

‡Ausgestattet mit Geschwindigkeitsmesser Tourenzähler.

*Montada haster de motor numero A65C — 367.

†Modelos 1965.

‡Equipado con indicador de velocidad y contador de vueltas.

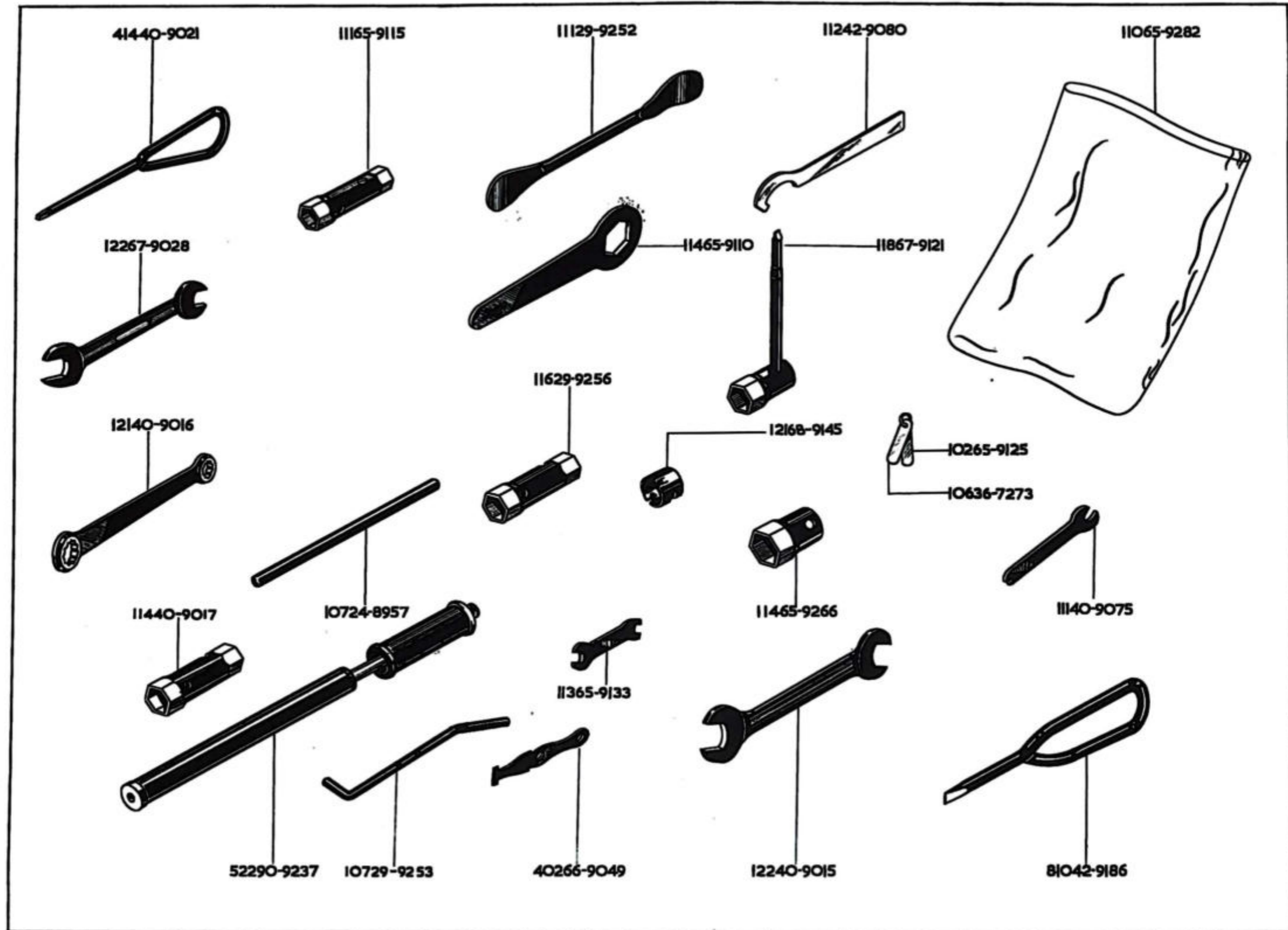

TOOLS, OUTILS, WERKZEUGE, HERRAMIENTOS

Model Modèle Typen Modelos	Spare No. No. de pièce Ersatzteil-Nr. No. de repuesto	Description	Designation	Beschreibung	Descripción
A65T/R	07 24-8957	Tommy Bar	Broche	Montierfisen	Barra para llaves de tubo
A50C, A65L/R, T/R, S/H	11 29-9252	Tyre Lever	Démonte-pneu	Reifenheber	Palanca desmonta neumaticos
A50C, A65L/R, S/H ...	07 29-9253	Tommy Bar	Broche	Montiereisen	Barra para llaves de tubo
A65T/R	16 29-9256	Box Spanner	Clé à tube	Steckschlüssel	Llave de tubo
A50C, A65L/R, S/H, T/R	06 36-7273	Feeler Gauge	Clé à tube	Steckschlüssel	Llave de tubo
A50C, A65L/R, S/H, T/R	06 36-7273	Feeler Gauge	Cale d'epaisseur	Spion	Calibrador de cinta
A65T/R	22 40-9015	Double-ended Spanner	Clé à fourche double	Doppelschraubenschlüssel	Llave de dos bocas
A50C, A65L/R, S/H, T/R	21 40-9016	Double-ended spanner	Clé à fourche double	Doppelschraubenschlüssel	Llave de dos bocas
A50C, A65L/R, S/H ...	14 40-9017	Box Spanner	Clé à tube	Steckschlüssel	Llave de tubo
A50C, A65L/R, S/H, T/R	14 40-9021	Screwdriver	Tournevis	Schraubenzieher	Destornillador
A50C, A65L/R, S/H, T/R	11 40-9075	Double-ended Spanner	Clé à fourche double	Doppelschraubenschlüssel	Llave de dos bocas
A50C, A65L/R, S/H, T/R	12 42-9080	Single-ended Spanner	Clé à fourche	Schraubenschlüssel	Llave de una bocas
A50C, A65L/R, S/H, T/R	10 42-9186	Screwdriver	Tournevis	Schraubenzieher	Destornillador
A50C, A65L/R, S/H, T/R	14 65-9110	Single-ended Spanner	Clé à une fourche	Schraubenschlüssel	Llave de una bocas
A50C, A65L/R, S/H, T/R	11 65-9115	Box Spanner	Clé à tube	Steckschlüssel	Llave de tubo
A50C, A65L/R, S/H, T/R	02 65-9125	Feeler Gauge	Cale d'epaisseur	Spion	Calibrador de cinta
A50C, A65L/R, S/H, T/R	13 65-9133	Double-ended Spanner	Clé à fourche double	Doppelschraubenschlüssel	Llave de dos bocas
A65T/R	14 65-9266	Box Spanner	Clé à tube	Steckschlüssel	Llave de tubo
A50C, A65L/R, S/H, T/R	10 65-9282	Toolbag	Trousse à outils	Werkzeugtasche	Bolsa de herramientas
A50C, A65L/R, S/H, T/R	02 66-9049	Cable Clip	Attache pour câble	Kabelklemme	Abrazadera de cable
A50C, A65L/R, S/H, T/R	22 67-9028	Double-ended Spanner	Clé à fourche double	Doppelschraubenschlüssel	Llave de dos bocas
A50C, A65L/R, S/H, T/R	18 67-9121	Box Spanner	Clé à tube	Steckschlüssel	Llave de tubo
A65T/R	46 68-9062	Toolkit complete	Outillage complet	Werkzeuge komplett	Herramientos completo
A50C, A65L/R, S/H ...	50 68-9066	Toolkit complete	Outillage complet	Werkzeuge komplett	Herramientos completo
A65T/R	21 68-9145	Box Spanner	Clé à tube	Steckschlüssel	Llave de tubo
A50C, A65L/R, S/H, T/R	22 90-9237	Tyre Inflator	Pompe à air	Luftpumpe	Bomba de aire