



REPLACEMENT PARTS CATALOGUE

FOR

1973 MODELS

45_{CU.IN.} [750_{C.C.}]

TRIDENT T150 V
SERIES 1

U.S.A. EDITION
PART NO. 99-0972



REPLACEMENT PARTS CATALOGUE

FOR 1973

TRIDENT T150V SERIES I

TRIUMPH ENGINEERING COMPANY LIMITED
MERIDEN WORKS • ALLESLEY • COVENTRY CV5 9AU • ENGLAND
TELEPHONE COVENTRY 20221 **TELEGRAMS "TRUSTY" COVENTRY**
MERIDEN 331 **TELEX "TRUSTY" 31305**

PUBLISHED AUGUST 1972

INTRODUCTION

The Triumph Engineering Co. Ltd. point out that the information contained in this catalog was complete and correct at the time of printing. Distributors will be informed of any subsequent alterations.

GUARANTEE

Please refer to your local dealer or distributor for the latest terms of guarantee.

Eastern U.S.A. Distributor:

Triumph Motorcycle Corporation,
P.O. Box 6790,
Towson,
Baltimore 4,
Maryland 21204.

Telex—Tricor Balt. 87728
Telephone—301-252-1700

Western U.S.A. Distributor:

Triumph Motorcycle Corporation,
P.O. Box 2765,
East Huntington Drive,
Duarte,
California 91010.

Telex—Tricor Duarte 675469
Telephone—213-359-3221
213-681-0255

ENGINE AND FRAME NUMBERS

The engine number is located on the left side of the engine, immediately below the cylinder barrel to crankcase flange.

The frame number is located on the left side of the frame headlug, beneath the fork top lug and forward of the gasoline tank.

Both the engine and frame number should be quoted in full in any correspondence relating to the machine.

COPYRIGHT

All rights reserved. No part of this publication may be reproduced without permission.

PROPRIETARY GROUP

AMENDMENTS TO 1973 REPLACEMENT PARTS CATALOGUE 99-0982

TRIDENT T150V (SERIES 2)

Page No.	Line	Description	Remarks
9	1	71-3307 replaces 70-8778)	Crankshaft supplied complete with keys
9	24	71-3951 Rotor key — added)	
23	20	14-0302 replaces 14-1302	Interchangeable
29	12	57-4785 replaces 57-4548	Interchangeable
41	45	83-1752 replaces 83-3227	Interchangeable
43	11	70-5874 replaces 70-2271	To be used in conjunction with new exhaust system
49	17	70-2288 replaces 60-4181	Interchangeable
49	19	83-5150 replaces 97-4477	Interchangeable
51	2	37-4184 replaces 37-3900)	Only interchangeable as a set
51	8	37-4179 replaces 37-3773)	
51	12	37-4181 replaces 37-3752)	
51	—	37-4180 Spacer — added — 1 off)	
51	23	82-2184 replaces 60-2331	
63	8	83-5151 replaces 97-4446	Interchangeable
63	33	83-5147 replaces 83-4814	Interchangeable
63	37	97-0961 Cable grommet — added	5 off
65	2	21-2225 replaces 14-1401)	Replace as a set
65	3	60-4250 replaces 60-2329)	
65	4	14-0301 replaces 14-1301)	
65	16	83-5105 Cable grommet — added	
67	28	99-1235 added	Part number addition only
67	31	99-1268 added	Part number addition only
73	21	60-2391 Washer (speedo & tacho) added	4 off
73	21	21-0778 Nut (speedo & tacho) added	4 off

PROPRIETARY GROUP

Ancillary equipment which is fitted to our motor cycles is of the highest quality and is guaranteed by the manufacturers and not by ourselves. Any repairs or claims should be directed to the actual makers or their local agents who will always give owners every possible assistance. The following are the addresses of the various manufacturers:—

CARBURETORS.

Messrs. Amal Ltd.,
Holdford Road,
Witton,
Birmingham, 6.

CHAINS.

Renold Chains Ltd.,
Wythenshawe,
Manchester.

ELECTRICAL EQUIPMENT.

Messrs. J. Lucas Ltd.,
Gt. Hampton Street,
Birmingham, 18.

TIRES.

Dunlop Rubber Co. Ltd.,
Fort Dunlop,
Birmingham, 24.

The Avon Rubber Co. Ltd.,
Melksham
Wilts.

SPARK PLUGS.

Champion Sparking Plug Co. Ltd.,
Feltham,
Middlesex.

SPEEDOMETERS.

Messrs. Smiths Industries Ltd.,
Cricklewood Works,
London, N.W.2.

SUSPENSION UNITS.

Messrs. Girling Ltd.,
Birmingham Road,
West Bromwich,
Staffordshire.

INDEX

	<i>Page</i>		<i>Page</i>
AIR FILTER	59	MANIFOLDS	23, 43
ALTERNATOR	21	MOTOR PLATES	41
AUTO-ADVANCE UNIT	21	MOTOR TORQUE STAY	41
BATTERY CARRIER	59	MUFFLERS	43
BRAKE SWITCHES	73	OIL COOLER	53
CAMSHAFT, INLET AND EXHAUST	9	OIL PUMP	13
CARBURETOR	17	OIL TANK	57
CENTRE STAND	37	OIL FILTER	13
CHAINS	35	OVERSIZE PARTS	7
CHAINCASE	33	PISTONS	9
CLUTCH	31	PROP STAND	37
CLUTCH LEVER ASSEMBLY	65	PUSH RODS	19
COIL	73	REAR WHEEL	51
CONDENSER PACK	73	RECTIFIER	73
CONNECTING RODS	9	REFLECTORS	53
CONTACT BREAKER	21	ROCKERS	15
CONTROL CABLES	67	SIDE PANELS	61
CONTROL LEVERS	65	SPARK PLUGS	73
CRANKCASE	11	SPEEDOMETER	71
CRANKSHAFT	9	SPEEDOMETER GEARBOX	51
CYLINDERS	19	STEERING DAMPER	47
CYLINDER HEAD	15	STEERING RACES	37, 45
EXHAUST PIPES	43	SUSPENSION UNITS	39
EXHAUST PIPE ADAPTOR	15	SWINGING FORK	39
FLASHERS	75	SWITCHES	65
FENDERS	63	TABLE OF STANDARD HARDWARE	76
FOOTRESTS	41, 43	TACHOMETER	71
FRAME	37	TACHOMETER GEARBOX	71
FRONT BRAKE	49	TAIL LAMP	63
FRONT BRAKE LEVER	65	TAPPETS	19
FRONT FORKS	45	TIMING GEARS	9
FRONT WHEEL	49	TOOLKIT	69
GAS TANK	55	TWIN SEAT	61
GEARBOX	25, 27, 29	VALVES	15
HANDLEBARS	65	VALVE GUIDES	15
HANDLEBAR MOUNTINGS	47	WARNING LIGHTS	75
HEADLAMP	75	WIRING HARNESS	75
HEAT SINK	73	ZENER DIODE	73
HORN	73		
KICKSTARTER	25		



TRIDENT (T150V) TECHNICAL DATA

Bore and stroke...	67 x 70 mm. 2-67 x 2-751 ins.
Capacity	741 c.c. (45 cu. ins.)
Compression ratio	9.5 : 1
Spark plugs	Champion N3
Carburetors	3 Amal Concentric 626
				Main jet	150
				Needle jet106
				Throttle valve	No. 3½
Gearbox sprocket	18 teeth
Chains	Front	¾" Triplex x 82 links
				Rear	⅝" x ⅜" x 108 links
Capacities	Fuel Tank	4.2 U.S. galls. (3½ Imp. galls.) (15.94 litres)
				Oil Tank	7.2 U.S. pints (6 Imp. pints) (3.8 litres) working capacity
				Gearbox...	1½ U.S. pints (1¼ Imp. pints) (750 c.c.)
				Primary Chaincase	¾ U.S. pint (⅝ Imp. pints)(350 c.c.)
				Front Forks (each leg)	230 c.c.
Brakes	Front, diameter...	8" (20.32 cm.)
				Rear, diameter	7" (17.78 cm.)
Tire size	Front	4-10 x 19 ins.
				Rear	4-10 x 19 ins.

HOW TO USE THIS PARTS CATALOGUE

First check that the engine number of your machine is subsequent to that quoted on the title page.

Next consult the index on Page 4 for the parts or group of parts which you wish to locate. When you have located the parts make sure from the end columns that the part you have located does apply to your machine. If proprietary parts are listed only under manufacturers part numbers and marked 'reference only', they are not available from the factory.

List the quantities required as single units; do not ask for "2 pairs" or "3 dozen".

COLOR

Petrol tank—Hi-Gloss Jet/Black
Fenders —Chrome
Side covers—Black

N.B. It is important to state year and model of machine when ordering painted components.

PLEASE NOTE

THROUGHOUT THIS LIST, ASSEMBLIES ARE PRINTED IN CAPITALS AND THE COMPONENTS INCLUDED IN THAT ASSEMBLY ARE INDENTED IN THE DESCRIPTION COLUMN, REVERTING TO THE ORIGINAL ALIGNMENT WHEN THE ASSEMBLY IS COMPLETE. TO ORDER THE COMPLETE ASSEMBLY IT IS NECESSARY ONLY TO QUOTE THE ASSEMBLY NUMBER. ANY COMPONENT PARTS LISTED MAY ALSO BE OBTAINED SEPARATELY IF REQUIRED.

SPECIAL WORKSHOP TOOLS

A COMPLETE LIST OF WORKSHOP TOOLS CAN BE MADE AVAILABLE BY EITHER CONTACTING YOUR DEALER OR APPLYING DIRECT TO THE TRIUMPH SERVICE DEPARTMENT. IN MOST CASES THESE TOOLS ARE VERY COSTLY AS THEY ARE MADE ENTIRELY FOR WORKSHOP USE, AND THEREFORE, IT IS NOT RECOMMENDED THAT THE PRIVATE OWNER PURCHASES THE TOOLS IN ORDER TO AID SERVICING THE MACHINE ONCE OR TWICE ONLY. IN THESE CIRCUMSTANCES IT IS FAR MORE ECONOMICAL TO GET IN TOUCH WITH A RECOGNISED DEALER.

PISTON, PISTON RING AND BEARING OVERSIZES

PISTONS (Complete with rings, gudgeon pins and circlips)

These are in effect "carton, pack" assemblies

Compression ratio 9.5 : 1 {
 E9741 Std.
 E9762+10
 E9763+20
 E9764+40

PISTON RINGS

CP212 { 2 off E6838 Compression ring } Std.
 { 1 off E9739 Scraper ring }
 CP212/10 { 2 off E9016 Compression ring } +10
 { 1 off E9766 Scraper ring }
 CP212/20 { 2 off E9017 Compression ring } +20
 { 1 off E9767 Scraper ring }
 CP212/40 { 2 off E9018 Compression ring } +40
 { 1 off E9768 Scraper ring }

BIG END BEARINGS SHELLS

E5998 Shell Std.
 E9023 Shell —10
 E9024 Shell —20
 E9025 Shell —30
 E9026 Shell —40

MAIN BEARING SHELLS

E9027—·010 in. undersize
 E9028—·020 in. undersize
 E9029—·030 in. undersize
 E9030—·040 in. undersize

CYLINDER BARREL

E6529 Std.
 E12507+10
 E12508+20
 E12509+40

VALVE GUIDES

E13280+·002 in.
 E13281+·015 in.

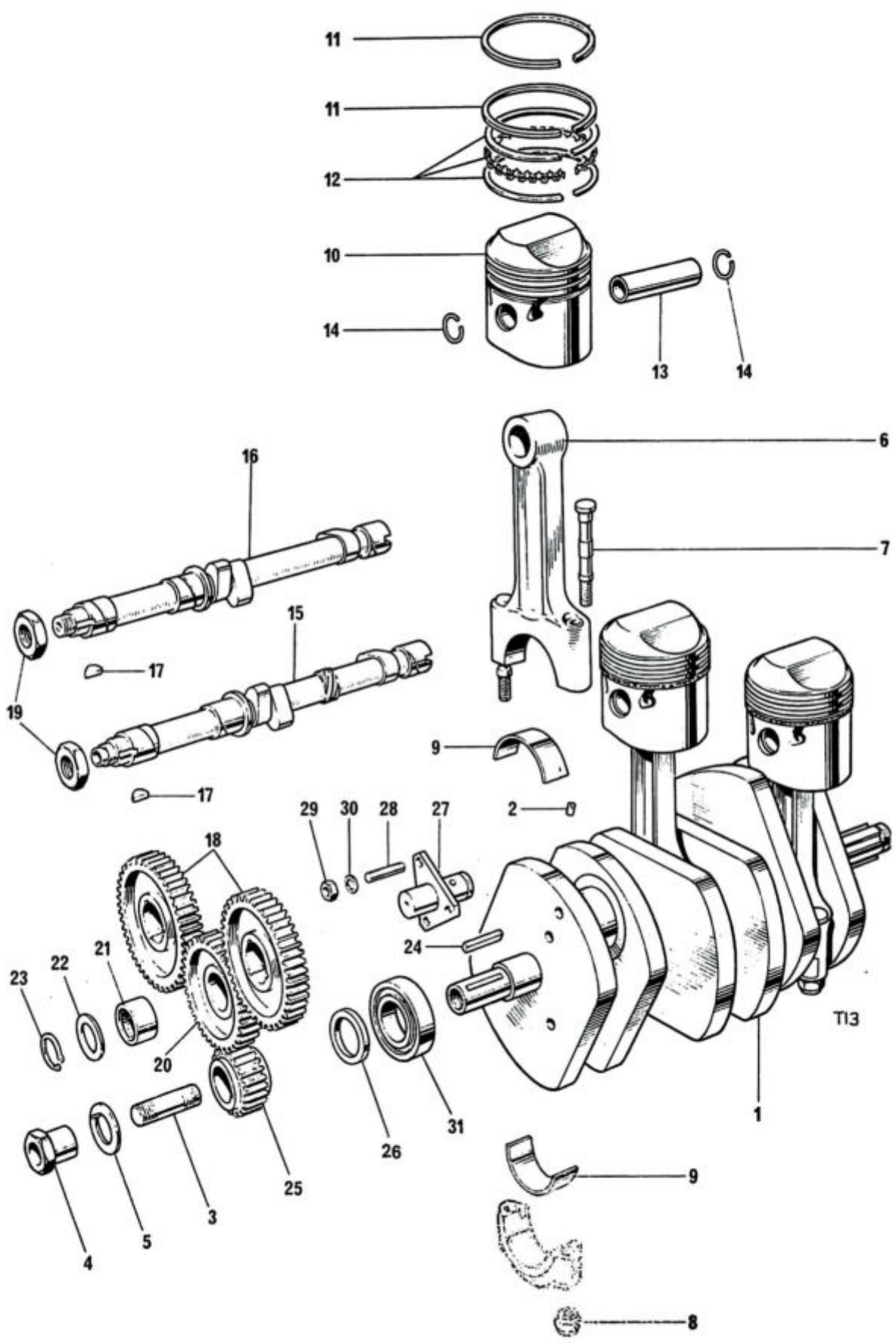

Fig. 1. CRANKSHAFT AND CONNECTING RODS

Ref. No. Part No. DESCRIPTION QUANTITY REMARKS

CRANKSHAFT AND CONNECTING RODS

1	E8778	CRANKSHAFT ASSEMBLY	1
2	E6577	Oilway plug	4
3	S548	Rotor stud (1 $\frac{3}{8}$ in. O.A.)	1
4	E8763	Rotor nut	1
5	E3975	Washer	1
6	E9740	CON ROD ASSEMBLY	3
7	E9727	Bolt con rod	2
8	D3761	Nut, con rod	2
9	E5998	*Bearing, big end	6
10	E9741	†PISTON ASSEMBLY	3
11	E6838	‡Taper piston ring	2
12	E9739	Scraper ring	1
13	E6836	Gudgeon pin	1
14	E6840	Circlip	2
15	E8765	Exhaust camshaft	1
16	E8764	Inlet camshaft	1
17	E1558	Key, camshaft	2
18	E12718	Pinion camshaft	2
19	E6523	Nut, camshaft	2
20	E12246	Intermediate timing gear	1
21	E7650	Needle roller bearing	1
22	E6088	Thrust washer	1
23	E8768	Circlip	1
24	E3974	Key—timing pinion and rotor	1
25	E6524	Timing pinion	1
26	E6173	Distance piece	1
27	E12250	Spindle, intermediate gear	1
28	S547	Stud ($\frac{7}{8}$ in. O.A.)	3
29	14-0401	Nut, intermediate gear	3
30	S26-2	Washer	3
31	E8780	Main bearing (roller)	1

* Available in undersizes of -0.010", 0.020", 0.030", 0.040"
 † Available in oversizes of +0.010", 0.020", 0.040"
 ‡ Available in oversizes of +0.010, 0.020", 0.040" } See page 7

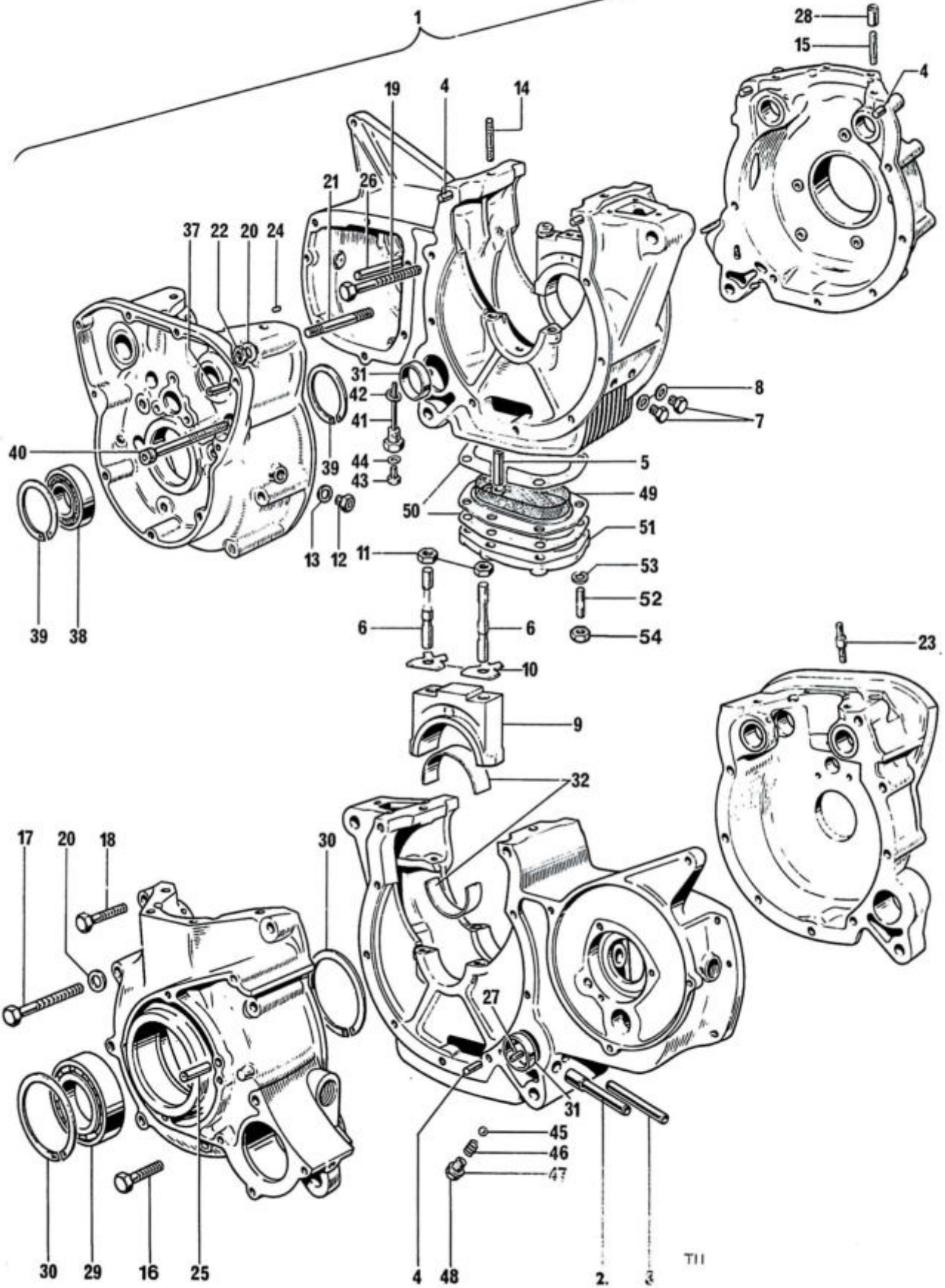

Fig. 2. CRANKCASES

Ref. No.	Part No.	DESCRIPTION	QUANTITY	REMARKS
CRANKCASES				
1	E13215	CRANKCASES	1	
2	E6573	Oil return pipe stub	1	
3	E6574	Oil feed pipe stub	1	
4	E8774	Dowel T.S. and D.S.	4	
5	E6578	Scavenge tube	1	
6	E8745	Waisted stud, main bearing cap	4	
7	14-6113	Plug, main bearing oilways	2	
8	E8776	Washer	2	
9	E13208	Cap, main bearing		Reference only
10	E11129	Tab washer	4	
11	14-0303	Nut	4	
12	E8755	Plug, timing aperture	1	
13	E1523	Washer, timing aperture	1	
14	S1931	Stud, cylinder base (1 $\frac{3}{4}$ in. O.A.)	4	
15	E8738	Stud, cylinder at dowel (1 $\frac{3}{8}$ in. O.A.)	2	
16	14 6218	Clamping bolt	2	
17	14-6226	Clamping bolt	9	
18	14-6220	Clamping bolt	2	
19	14-6223	Clamping bolt	1	
20	S25-3	Washer	9	
21	14-1427	Stud, T.S. crankcase	2	
22	14-0302	Nut	2	
23	S1912	Stud, cylinder base	4	
24	T912	Peg, needle roller thrust	1	
25	E11051	Spindle, intermediate gear (oil pump)	1	
26	T3989	Selector spindle	1	
27	E1532	Dowel, oil pump to crankcase	1	
28	E8751	Dowel, cylinder base	2	
29	E1591	D.S. main bearing	1	
30	E6025	Circlip, main bearing	2	
31	E9856	Sleeve at 'O' ring	2	
32	E6023	*Main Bearing Shell	4	
33	T989	Dowel	2	
34	E8780	Main bearing T.S. (roller)	1	
35	E6026	Circlip	2	
36	S678	Socket screw (4 in. U.H.)	1	
37	T3851	Gearbox drain plug	1	
38	E2441	Fibre washer	1	
39	S543	Level plug	1	
40	T1257	Fibre washer	1	
41	D2370	Non return valve ball ($\frac{7}{16}$ in. dia.)	1	
42	E6567	Spring	1	
43	E12792	Joint washer (copper)	1	
44	E6584	Plug	1	
45	E6501	Scavenge filter	1	
46	E11444	Gasket	2	
47	E6580	Cover	1	
48	E11349	Stud, sump plate	6	
49	D2320	Spring washer	6	
50	14-0301	Nut	6	

*Available in undersizes of 0-010", 0-020", 0-030", 0-040" (see page 7).

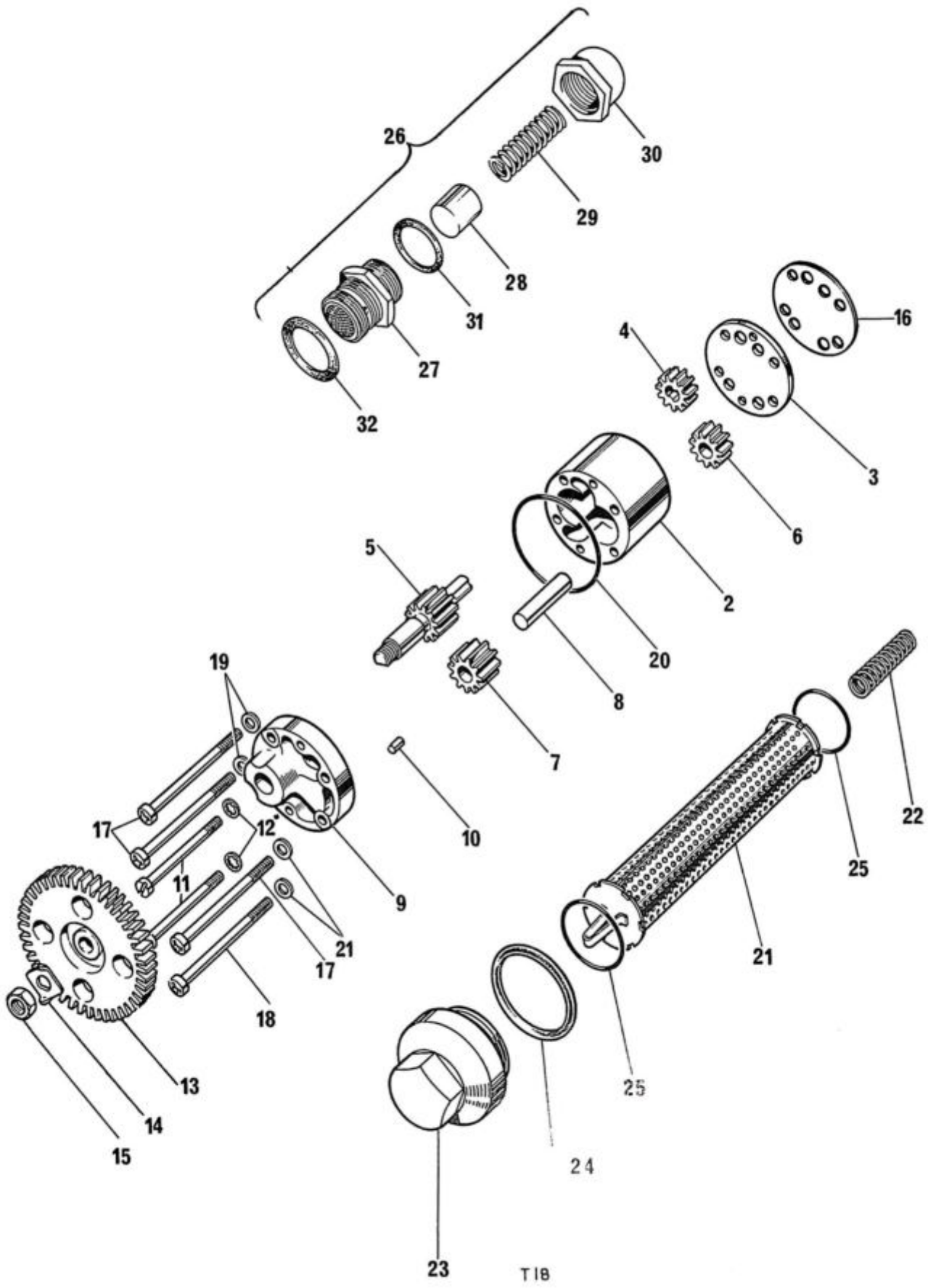

Fig. 3. OIL PUMP, RELEASE VALVE AND FILTER

Ref. No.	Part No.	DESCRIPTION	QUANTITY	REMARKS
OIL PUMP RELEASE VALVE AND OIL FILTER				
1	E11351	OIL PUMP COMPLETE	1	
2	E6430	Oil pump, body	1	Reference only
3	E6502	Base plate	1	
4	E6455	Drive feed gear	1	
5	E9887	Drive scavenge gear	1	
6	E6038	Driven feed gear	1	
7	E6039	Driven scavenge gear	1	
8	E6454	Driven gear spindle	1	
9	E9885	Cover	1	
10	E6459	Dowel, cover to body	1	
11	S559	Screw, cover to body (2 in. U.H.)	2	
12	E8731	Washer, cover to pump screw	2	
13	E9886	Driven gear	1	
14	E11353	Tab washer	1	
15	14-0402	Nut	1	
16	E11442	Gasket, oil pump to crankcase	1	
17	E10003	Screw, pump to crankcase (2½ in. U.H.)	3	
18	E9601	Screw, pump to crankcase at dowel (2¾ in. U.H.)	1	
19	E8732	Washer, pump to crankcase	4	
20	E6570	Seal, pump to crankcase	1	
21	E6571	Oil filter element	1	
22	E6130	Spring	1	
23	E11270	Cap	1	
24	E11070	'O' ring	1	
25	E8779	Filter seal	2	
Not illus.	D2133	Oil pressure switch	1	
26	E6595	OIL PRESSURE RELEASE VALVE	1	
27	E7590	Body	1	Reference only
28	E8752	Piston	1	
29	E7591	Spring	1	
30	E6596	Cap	1	
31	E8754	Joint washer (cap to body)	1	
32	E1670	Joint washer	1	

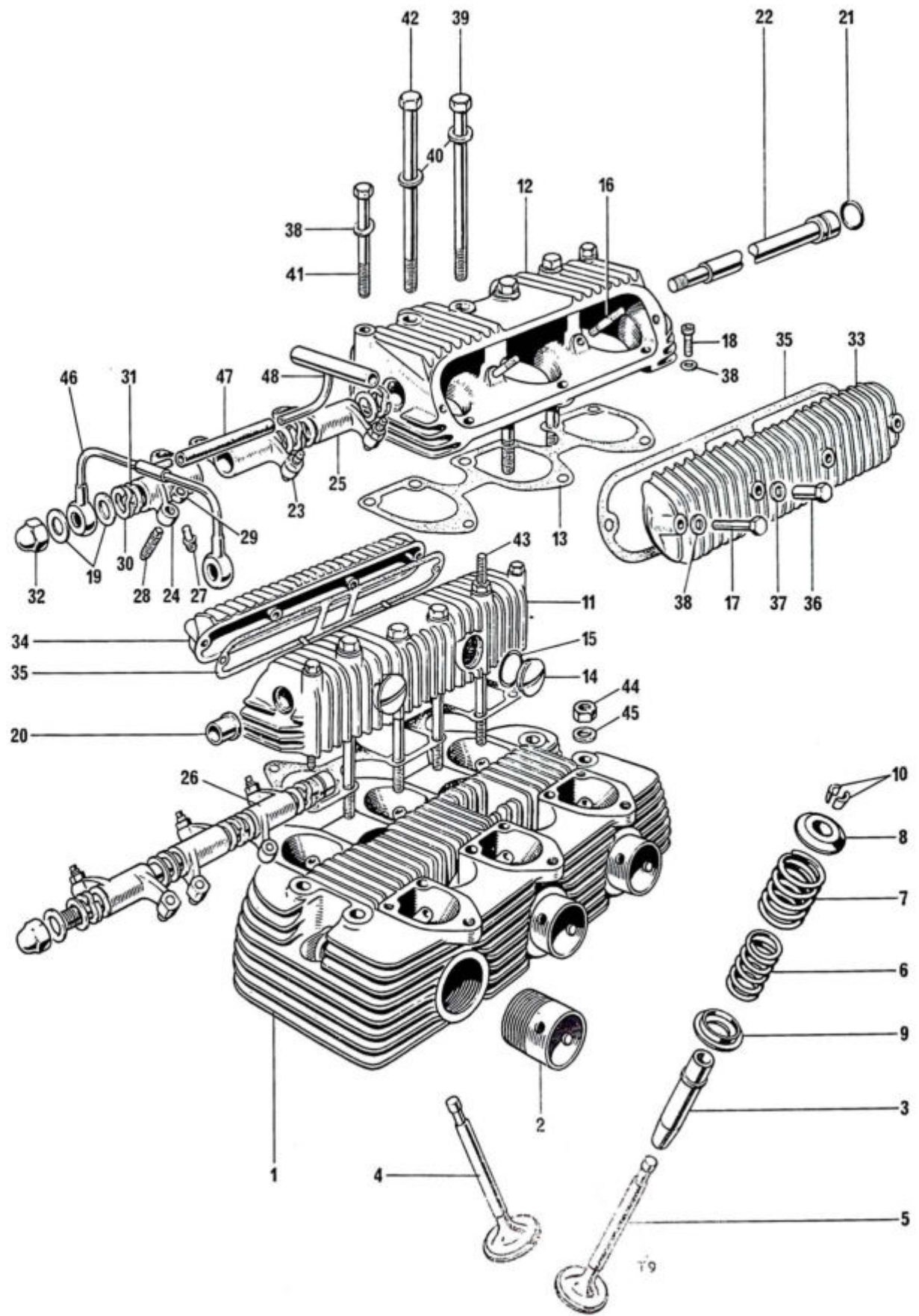

Fig. 4. CYLINDER HEAD AND ROCKER BOXES

Ref. No.	Part No.	DESCRIPTION	QUANTITY	REMARKS
CYLINDER HEAD AND ROCKER BOXES				
1	E8781	CYLINDER HEAD	1	
2	E9510	Exhaust pipe adaptor	3	
3	E6420	Valve guide	6	
4	E13361	Inlet valve	3	
5	E13362	Exhaust valve	3	
6	E8787	Inner, valve spring (White and red paint dabs)	6	
7	E8788	Outer, valve spring (White and red paint dabs)	6	
8	E8720	Top collar	6	
9	E8789	Bottom cup	6	
10	99-0062	Split cotter	12	
11	E6561	Inlet rocker box	1	
12	E6562	Exhaust rocker box	1	
13	E8773	Rocker box gasket	2	
14	T2166	Rocker box cap	4	
15	E8782	"O" ring cap	4	
16	14-1401	Stud, rocker box cover	4	
17	14-0202	Bolt, rocker box cover	4	
18	14-7004	Screw	6	
19	E1335	Copper washer	4	
20	E6018	Bush, T.S. for rocker spindle	2	
21	D3548	"O" ring, D.S. bush	2	
22	E9558	Rocker spindle	2	
23	E13587	ROCKER LEVER, T.S. INLET/CENTRE EXHAUST	2	
24	E13588	ROCKER LEVER, T.S. EXHAUST/CENTRE INLET	2	
25	E13589	ROCKER LEVER, EXHAUST D.S.	1	
26	E13590	ROCKER LEVER, INLET D.S.	1	
27	E10070	Ball pin	6	
28	E13358	Adjusting pin	6	
29	14-0402	Locknut	6	
30	E1574	Thackeray washer	6	
31	E1575	Plain washer	12	
32	S550	Dome nut	2	
33	E6564	Inspection cover, exhaust	1	
34	E6563	Inspection cover, inlet	1	
35	E11445	Gasket	2	
36	E9237	Sleeve nut	4	
37	E9239	Plain washer	4	
38	S25-1	Washer	8	
39	E8820	Bolt, short rockerbox to barrel ($\frac{5}{16}$ " x $4\frac{1}{4}$ ")	4	
40	E9240	Washer	8	
41	14-6211	Bolt, rocker box to head	4	
42	E8819	Bolt, rocker box to barrel ($\frac{5}{16}$ " x $4\frac{1}{2}$ ")	2	
43	E10280	Bolt, torque stay, rocker box to barrel ($5\frac{1}{32}$ in.)	2	
44	14-0303	Nut	4	
45	F2184	Washer	4	
46	E11168	Rocker pipe	1	
47	E11175	Connecting tube	1	
48	E11172	Oil feed pipe	1	

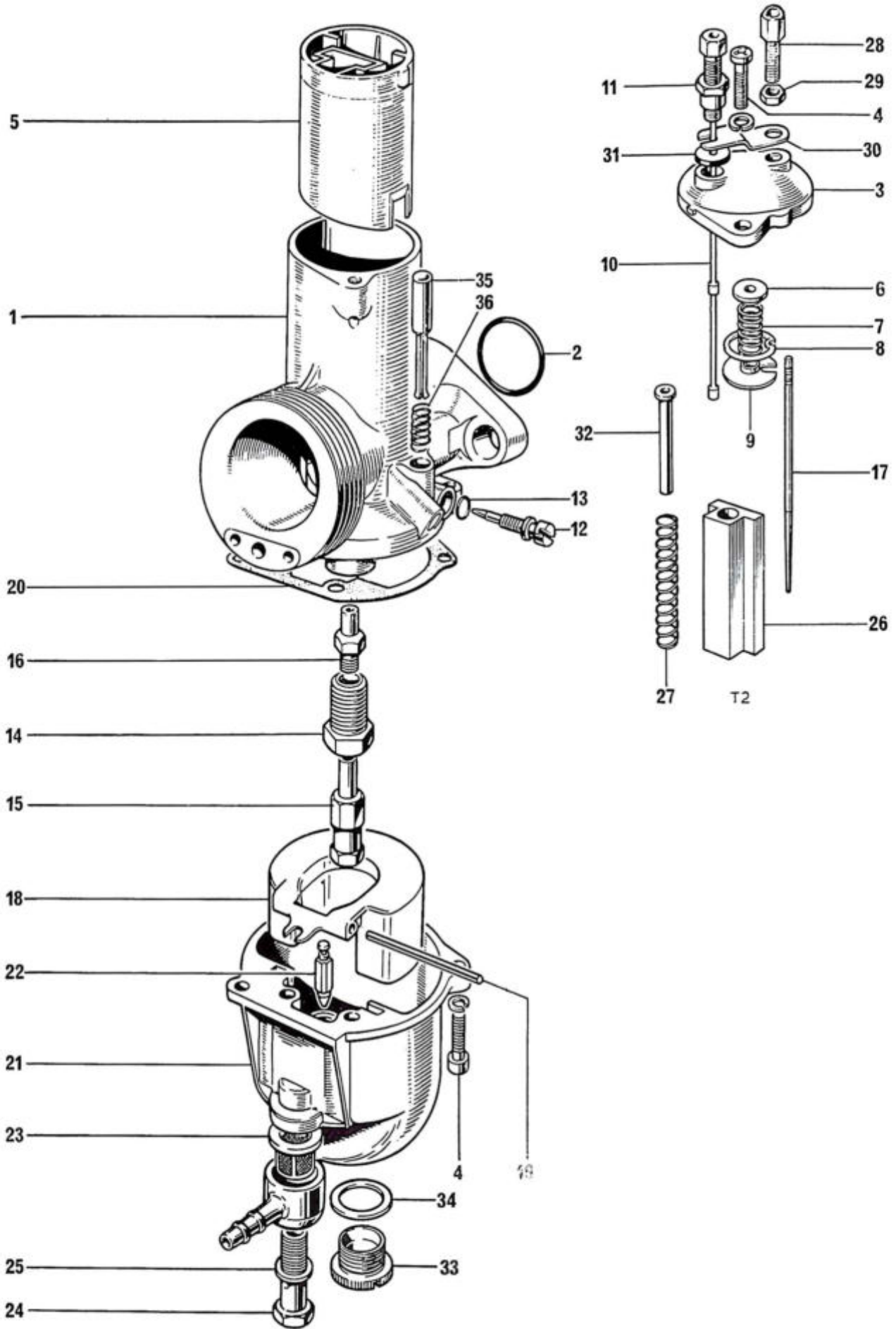

Fig. 5. CARBURETORS

Ref. No.	Part No.	DESCRIPTION	QUANTITY	REMARKS
CARBURETORS				
1	D4092	CARBURETOR R.H. (Amal R626/66)	1	
1	D4094	CARBURETOR CENTRE (Amal R626/68)	1	
1	D4093	CARBURETOR L.H. (Amal. L626/67)	1	
2	622/101	'O' ring seal (99-0522)	3	
3	622/097	Mixing chamber top (99-1019)	1	} Each Carburetor
4	622/086	Screw (99-0521)	4	
5	622/060	Throttle valve (No. 3½) (99-0506)	1	
6	D1959	Top spring abutment	1	
7	D1960	Spring	1	
8	622/067	Needle clip (99-0510)	1	
9	D1987	Bottom spring abutment... ..	1	
10	D1984	Throttle rod assembly	1	
11	E9253	Locknut	1	
12	622/076	Pilot air screw (99-0515)... ..	1	
13	622/082	Friction 'O' ring (99-0520)	1	
14	622/128	Jet holder (99-0519)	1	
15	376/100	Main jet (150) (99-1020)... ..	1	
16	622/122	Needle jet (106) (99-1035)	1	
17	622/124	Needle (Standard) (99-1036)	1	
18	622/069	Float (99-0512)	1	
19	622/071	Float spindle (99-0513)	1	
20	622/073	Joint washer (99-0514)	1	
21	622/050	Float chamber (99-0506)	1	
22	622/068	Float needle (99-0511)	1	
23	376/093	Filter (99-0438)	1	
24	622/078	Banjo bolt (99-0517)	1	
25	13/163	Fibre washer (99-1100)	1	
26	622/062	Air slide (99-1021)	1	
27	622/065	Spring (99-0509)	1	
28	4/035	Cable adjuster (99-1024)	1	
29	5/077	Locknut (99-0224)... ..	1	
30	622/105	Clip (99-1022)	1	
31	622/126	Sealing rubber (99-1023)	1	
32	622/134	Air slide guide tube (99-1051)	1	
33	622/147	Drain plug (99-1152)	1	
34	622/151	Washer (99-1153)	1	
35	622/089	Tickler pin	1	
36	14/032	Tickler pin spring	1	Reference only

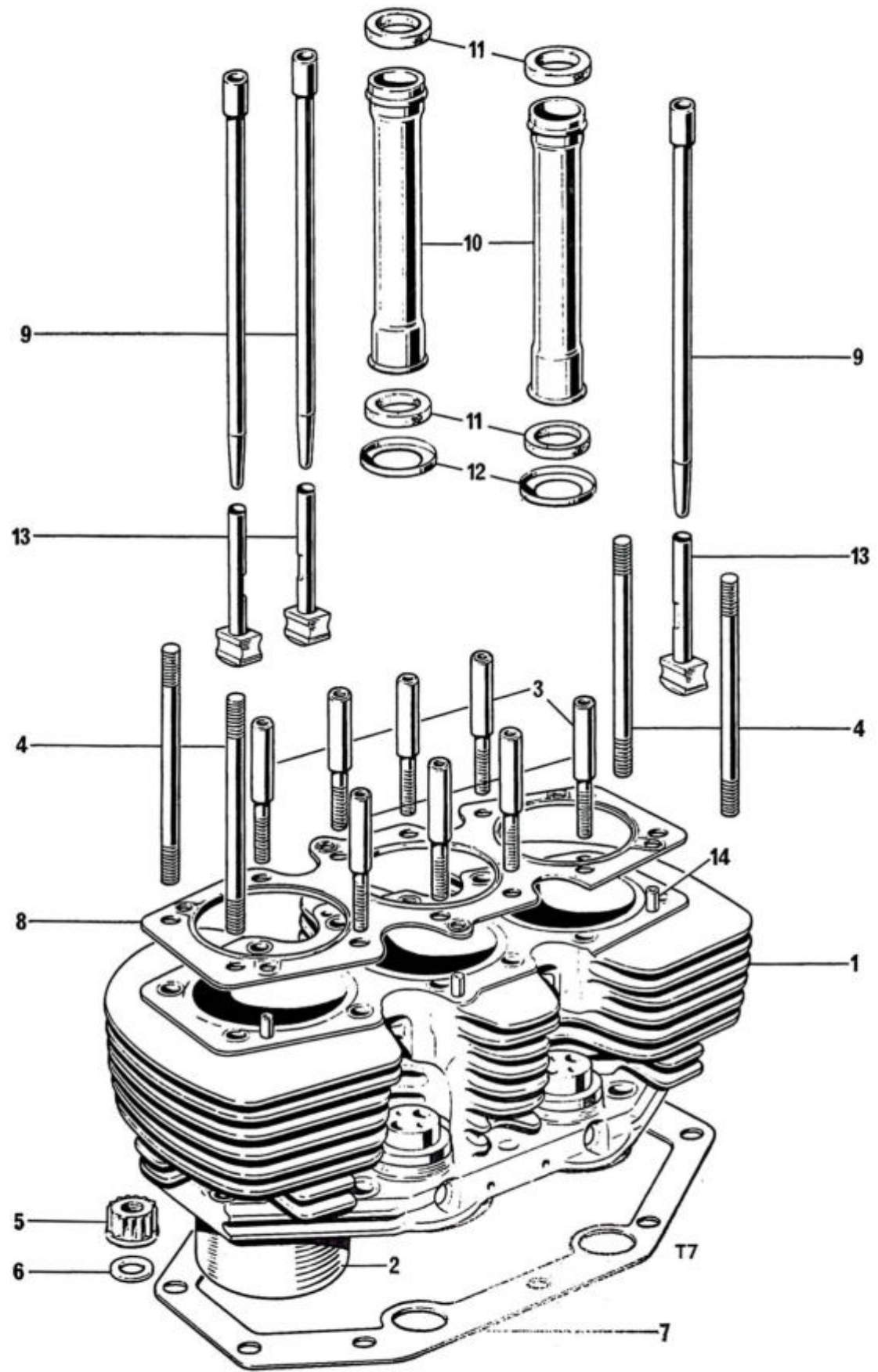

Fig. 6. CYLINDER BARREL, PUSH ROD AND TUBES, TAPPETS

Ref. No.	Part No.	DESCRIPTION	QUANTITY	REMARKS
CYLINDER BARREL, PUSH RODS AND TUBES, TAPPET BLOCKS				
1	E13209	CYLINDER BARREL C/W LINERS	...	1
2	E8914	Cylinder liner	...	3
3	E8817	Pillar stud	...	8
4	S686	Stud, barrel to head ($4\frac{5}{8}$ in. O.A.)	...	4
5	S692	Base nut (12 point)	...	10
6	E8770	Washer	...	10
7	E6496	Cylinder base gasket	...	1
8	E11733	Cylinder head gasket	...	1
9	E11238	Push rod	...	6
10	E6955	Push rod tube	...	4
11	E4752	Sealing rubber	...	8
12	E4746	Bottom cup	...	4
13	E13213	Tappet	...	6
14	E1532	Dowel	...	6
Not illus.	E11190	Gasket, push rod cover tube	...	4

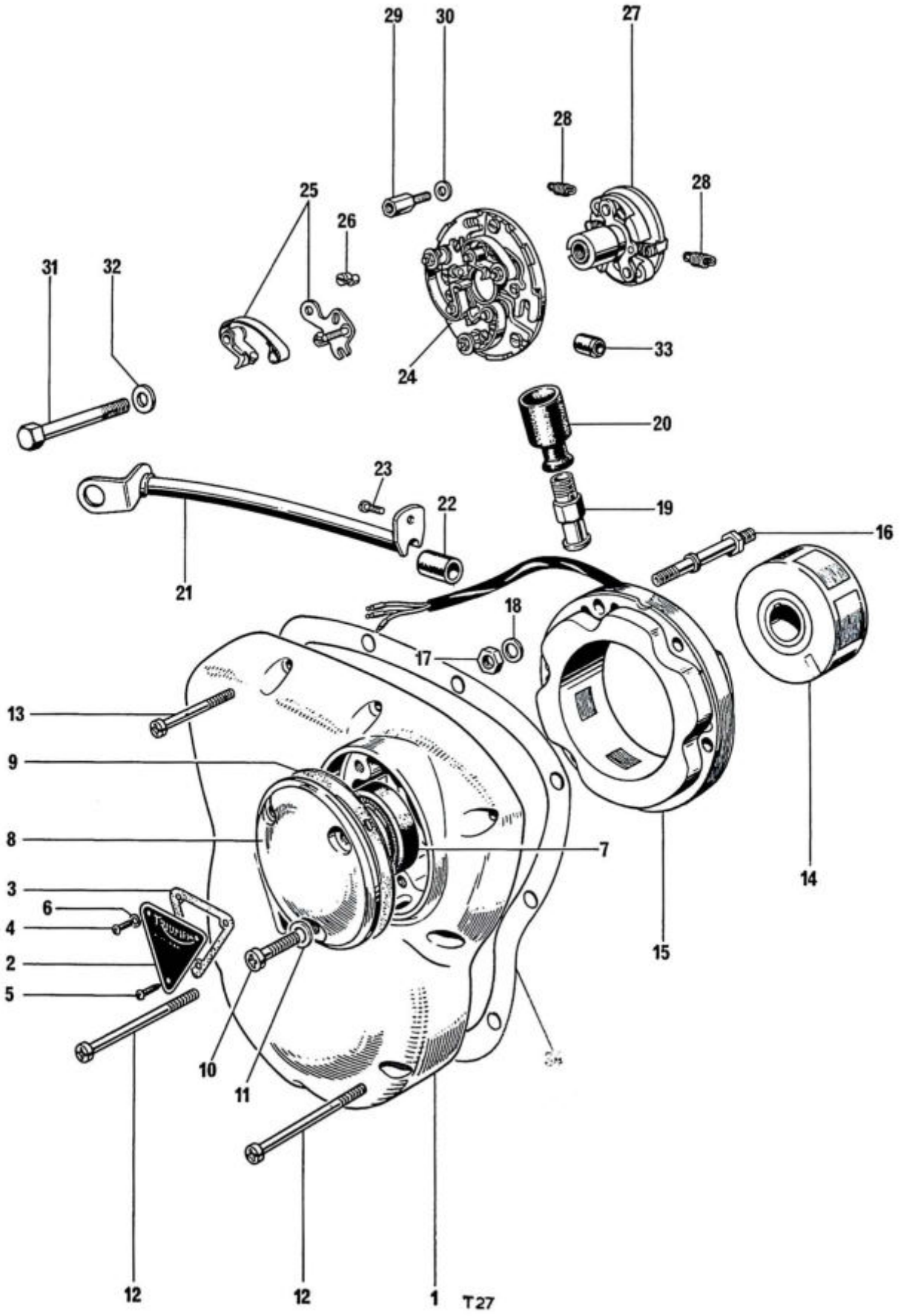

Fig. 7. TIMING COVER AND CONTACT BREAKER

Ref. No.	Part No.	DESCRIPTION	QUANTITY	REMARKS
TIMING COVER AND CONTACT BREAKER				
1	E6432	Timing cover	1	
2	E8762	Cover, timing aperture	1	
3	E11440	Joint washer	1	
4	E10007	Screw ($\frac{5}{16}$ in. U.H.)	2	
5	E10006	Pointer screw	1	
6	E9266	Washer	3	
7	E4568	Oil seal	1	
8	E6519	C:B. cover	1	
9	E11441	Gasket C:B. cover	1	
10	F4715	Screw ($\frac{1}{2}$ in. U.H.)	3	
11	H430	Washer	3	
12	14-6612	Screw	3	
13	14-6608	Screw	6	
14	54213901	Rotor (99-0739)—RM 21	1	
15	47205	Stator (99-1016)—RM 20	1	
16	E6522	Stud, alternator mounting	3	
17	S1852	Nut, alternator mounting	3	
18	S25-3	Washer	3	
19	E8760	Cable seal nut	1	
20	E4144	Grommet	1	
21	E8757	Cover, alternator leads	1	
22	E8756	Rubber ferrule	1	
23	H916	Screw, lead cover to crankcase ($\frac{5}{16}$ in. U.H.)	1	
24	54419327	CONTACT BREAKER 7CA (99-1233)	1	
25	54419828	Contact set (99-1014)	3	
26	54419220	Adjusting screw (99-0769)	3	
27	54419867	AUTO ADVANCE UNIT (99-1015)	1	
28	54417992	Spring (99-1234)	2	
29	E6521	Pillar bolt	3	
30	E6559	Washer	3	
31	14-0208	Bolt C.B.	1	
32	S25-43	Washer	1	
33	E8756	Grommet	1	
Not illus.	H2123	Distance piece, stator	6	
34	E11350	Gasket timing cover	1	
Not illus.	D3748	Transfer "5 speed"	1	

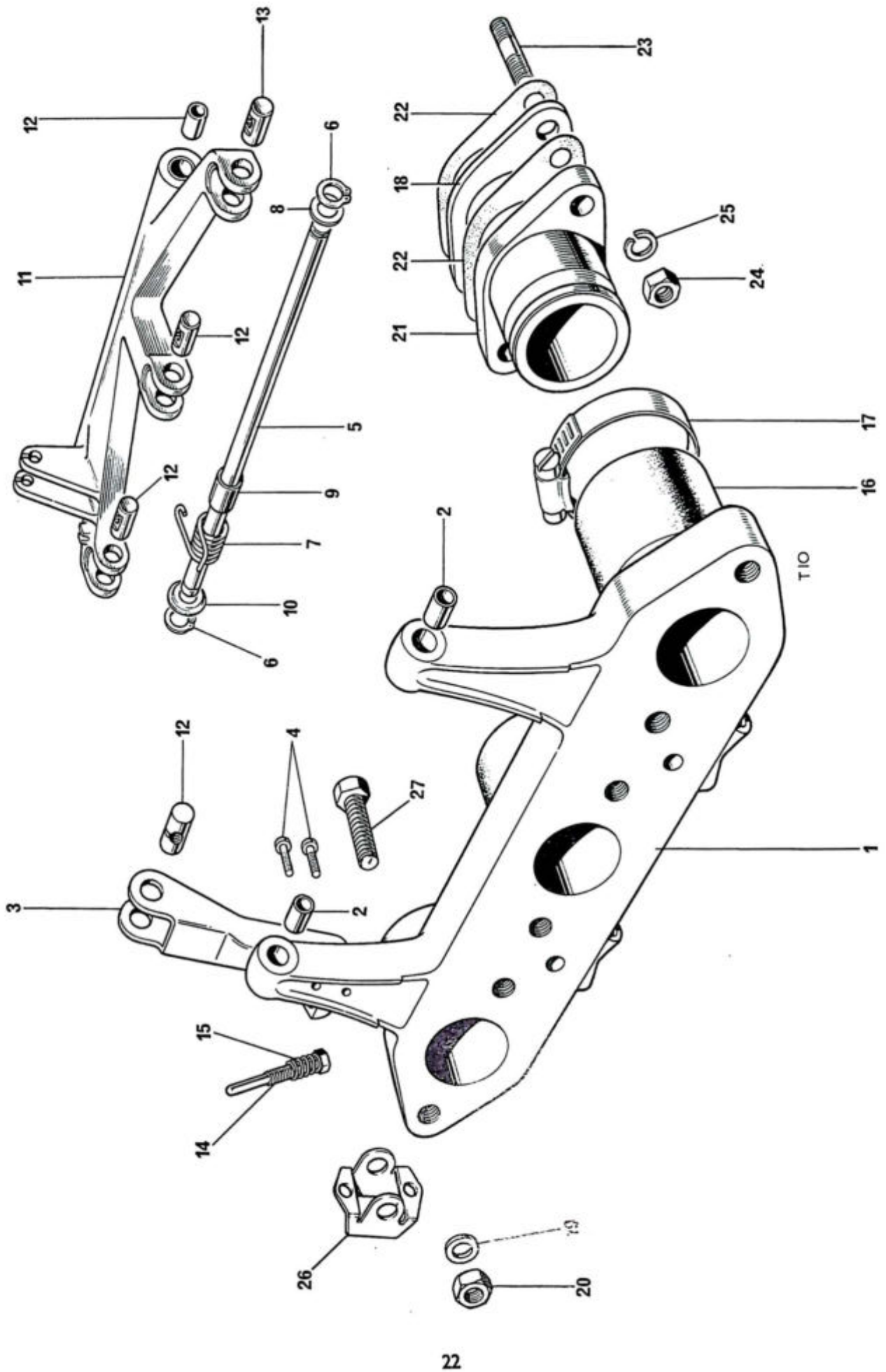

Fig. 8. MANIFOLD AND THROTTLE LINKAGE

Ref. No.	Part No.	DESCRIPTION	QUANTITY	REMARKS
MANIFOLD AND THROTTLE LINKAGE				
1	E11303	ADAPTOR c/w BUSHES	1	
2	E9073	Bush	2	
3	E9242	Support arm	1	
4	S1930	Screw self-tapping	2	
5	E9251	Spindle	1	
6	E9255	Circlip	2	
7	E13311	Return spring	1	
8	E10245	Washer	1	
9	E9820	Spacer	1	
10	E9821	Retaining cup	1	
11	E9278	Operating arm	1	
11A	E9073	Bush	2	
12	E9243	Trunnion	4	
13	E9252	Screw	1	
14	E9254	Spring	1	
15	E9060	Rubber sleeve	3	
16	D707	Jubilee type clip	6	
17	E8981	Insulating block	3	
18	14-1619	Stud cylinder head	6	
19	S25-3	Washer	6	
20	14-1302	Nut, carburetter fixing	6	
21	E9057	Stub, cylinder head	3	
22	E11446	Joint washer, stub to head	5	
23	S557	Stud (1 $\frac{5}{32}$ " O.A.)	6	
24	14-1301	Nut, cylinder head	6	
25	S25-13	Washer	6	
26	F13665	Bracket, air control lever	1	
27	14-0218	Bolt	1	
Not illus.	E13312	Spring, carbureter slide	3	

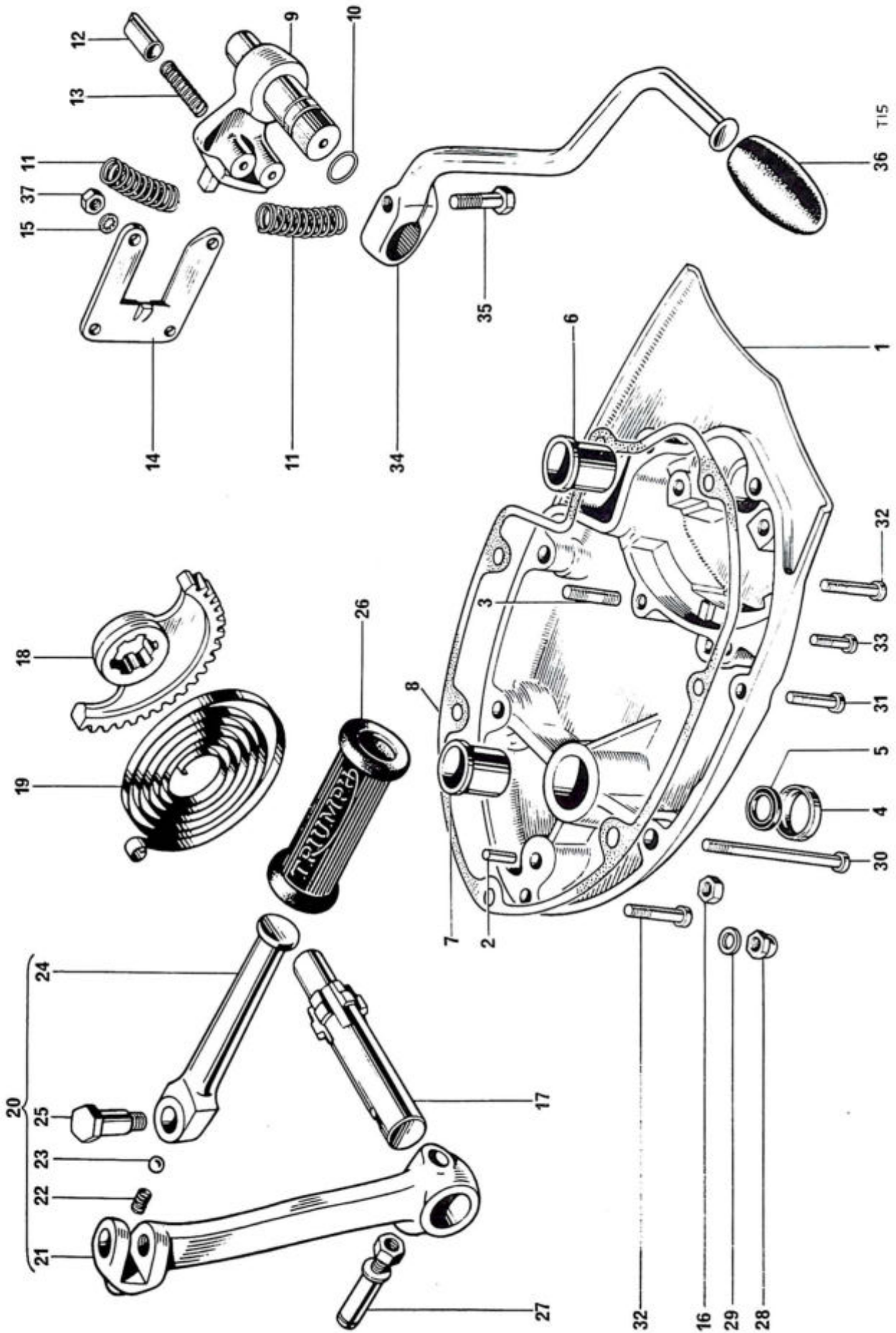

Fig. 9. GEARBOX OUTER COVER

Ref. No.	Part No.	DESCRIPTION	QUANTITY	REMARKS
----------	----------	-------------	----------	---------

GEARBOX OUTER COVER

1	T3750	GEARBOX OUTER COVER	1
2	T47	Kickstart anchor peg	1
3	S547	Stud guide plate (7/8 in. O.A.)	4
4	T1955	Housing, oil seal	1
5	T1956	Oil seal	1
6	T57	Bush (F/C Spindle)	1
7	T23	Bush (K/S Spindle)	1
8	E11448	Gasket, outer to inner gearbox	1
9	T4374/408	Plunger quadrant	1
10	D3530	Sealing Ring	1
11	T404	Spring	2
12	T4403	Plunger	2
13	T405	Spring	2
14	T407	Guide plate	1
15	E1612	Washer	4
16	14-1302	Nut	4
17	T24A	Kickstart axle shaft	1
18	T4117	Kickstart quadrant	1
19	T31	Kickstart return spring	1
20	T3632	FOLDING KICKSTART COMPLETE	1
21	T2173	Crank	1
22	T1167	Spring	1
23	D2364	Ball, 1/4 in. dia.	1
24	T1272	Pedal	1
25	S541	Pivot bolt	1
26	T2330	Rubber	1
27	T4356	Cotter pin c/w nut and washer	1
28	S544	Domed nut outer cover	2
29	S25-3	Washer	2
30	S2140	Screw, outer cover long	1
31	14-6609	Screw, outer cover	1
32	14-6610	Screw, outer cover	2
33	14-6608	Screw, outer cover	1
34	T3751	Gearchange pedal	1
35	14-0201	Pinch bolt	1
36	T2450	Rubber	1
37	14-0301	Nut	4

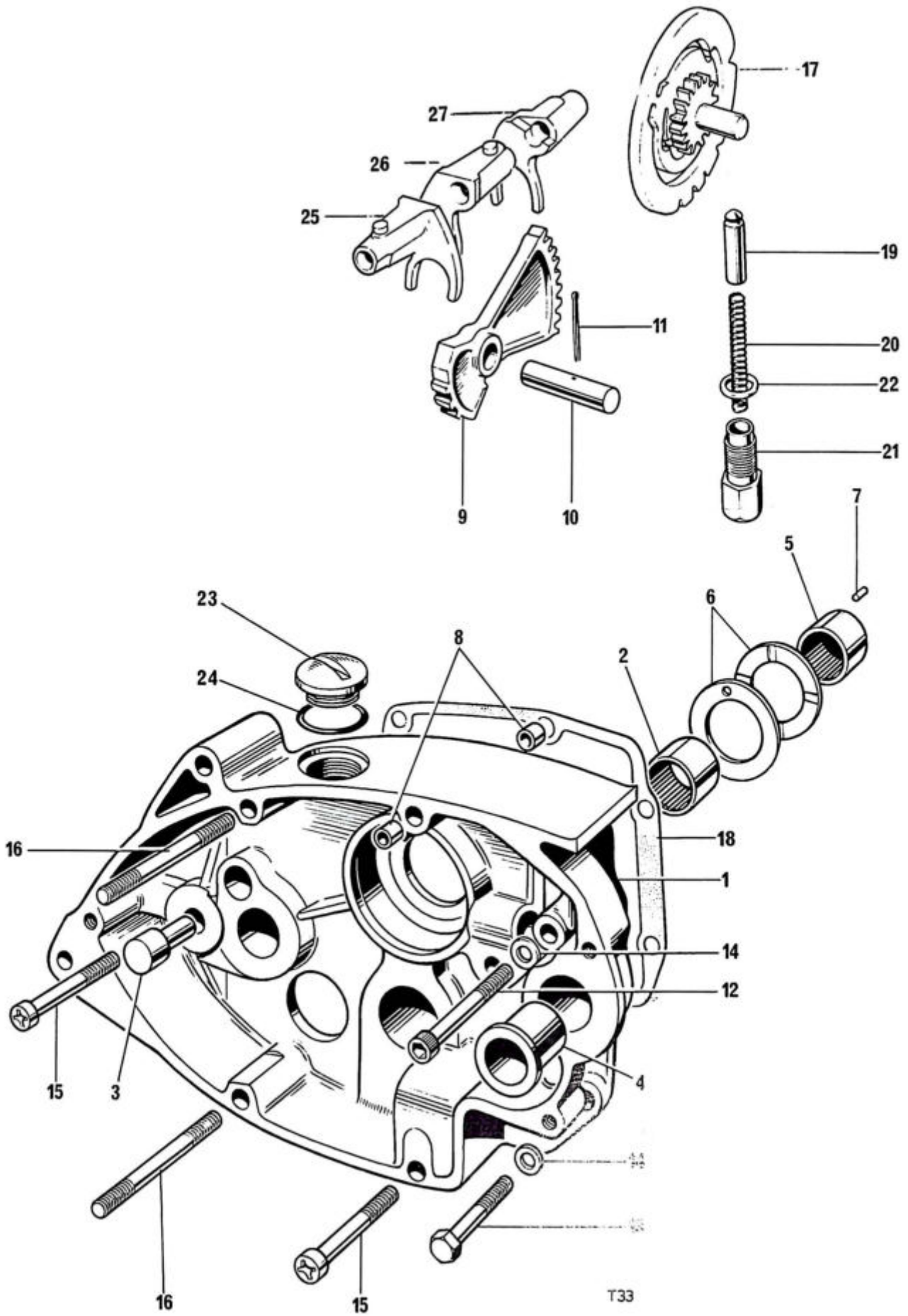

Fig. 10. GEARBOX INNER COVER AND SELECTORS

Ref. No. Part No. DESCRIPTION QUANTITY REMARKS

GEARBOX INNER COVER AND SELECTORS

Ref. No.	Part No.	DESCRIPTION	QUANTITY	REMARKS
1	T4327	INNER COVER	1	
2	T1614	Layshaft Bearing	1	
3	T45	Kickstart stop	1	
4	T412	Bush (F/C spindle)	1	
5	T1606	Layshaft, needle roller bearing	1	
6	T1607	Thrust washer	2	
7	T912	Peg, L/S thrust washer		(Also in crank-case group)
8	T989	Dowel, inner to outer cover	2	
9	T4363	Quadrant	1	
10	T1896	Quadrant spindle	1	
11	—	Split pin (5/64 in. x 1 3/8 in.)		Reference only
12	14-7101	Socket screw	1	
13	14-6121	Bolt, inner cover to crankcase	1	
14	E3446	Washer, inner cover to crankcase	2	
15	S1917	Screw inner cover to crankcase	2	
16	14-1431	Stud, gearbox cover	2	
17	T4624	Camplate	1	
18	E11447	Gasket, inner cover to crankcase	1	
19	T3660	Plunger	1	
20	T4459	Plunger spring	1	
21	T4400	Plunger sleeve nut	1	
22	T3978	Washer	1	
23	T2166	Filler cap	1	
24	E8782	"O" ring	1	
25	T4364	Selector fork – m/s 4th gear	1	
26	T4366	Selector fork – 1/s 3rd gear	1	
27	T4660	Selector fork – 1/s 1st gear	1	

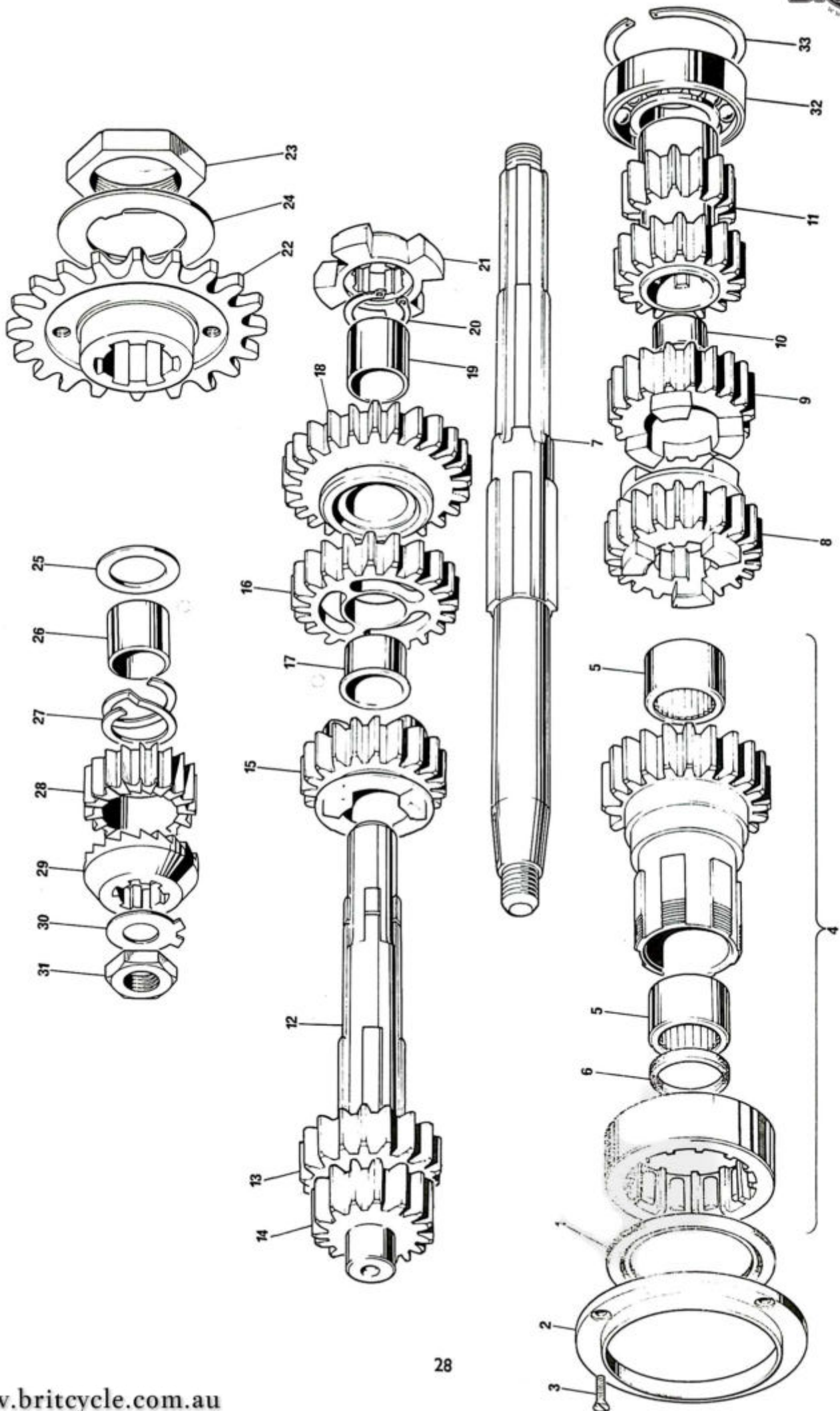

FIG. 12. GEARBOX SHAFTS AND GEARS

Ref. No.	Part No.	DESCRIPTION	QUANTITY	REMARKS
GEARBOX SHAFTS AND GEARS				
1	D3510	Oil seal	1	
2	T4394	Housing – oil seal housing	1	
3	S2106	Screw	3	
4	T4628	MAINSHAFT HIGH GEAR ASSEMBLY (c/w bearing)	1	
5	D3511	Needle Roller bearing	2	
6	D3500	Oil Seal	1	
7	T4370	Mainshaft	1	
8	T4376	Mainshaft 4th gear	1	
9	T4377	MAINSHAFT 3rd GEAR	1	
10	T4575	Bush	Reference only	
11	T4653	Mainshaft 1st and 2nd gear	1	
12	T4548	Layshaft	1	
13	T4384	Layshaft, 4th gear	Reference only	
14	T4550	Layshaft high gear	Reference only	
15	T4647	Layshaft 3rd gear	1	
16	T4657	LAYSHAFT 2nd GEAR	1	
17	T4662	Bush	1	
18	T4654	LAYSHAFT 1st GEAR	1	
19	T4663	Bush	1	
20	D3494	Circlip	1	
21	T4661	Driving dog	1	
22	T4398	Gearbox sprocket – 18T	1	
23	T4396	Locknut	1	
24	T4395	Lock washer	1	
25	T1962	Washer	1	
26	T1963	Pinion sleeve	1	
27	T1250	Pinion spring	1	
28	T730	Kickstart pinion	1	
29	T731	Kickstart ratchet	1	
30	T2240	Tab washer	1	
31	S594	Nut	1	
32	D3552	Mainshaft bearing	1	
33	T4113	Bearing Circlip	1	

N.B. High gear bearing not available as a separate item

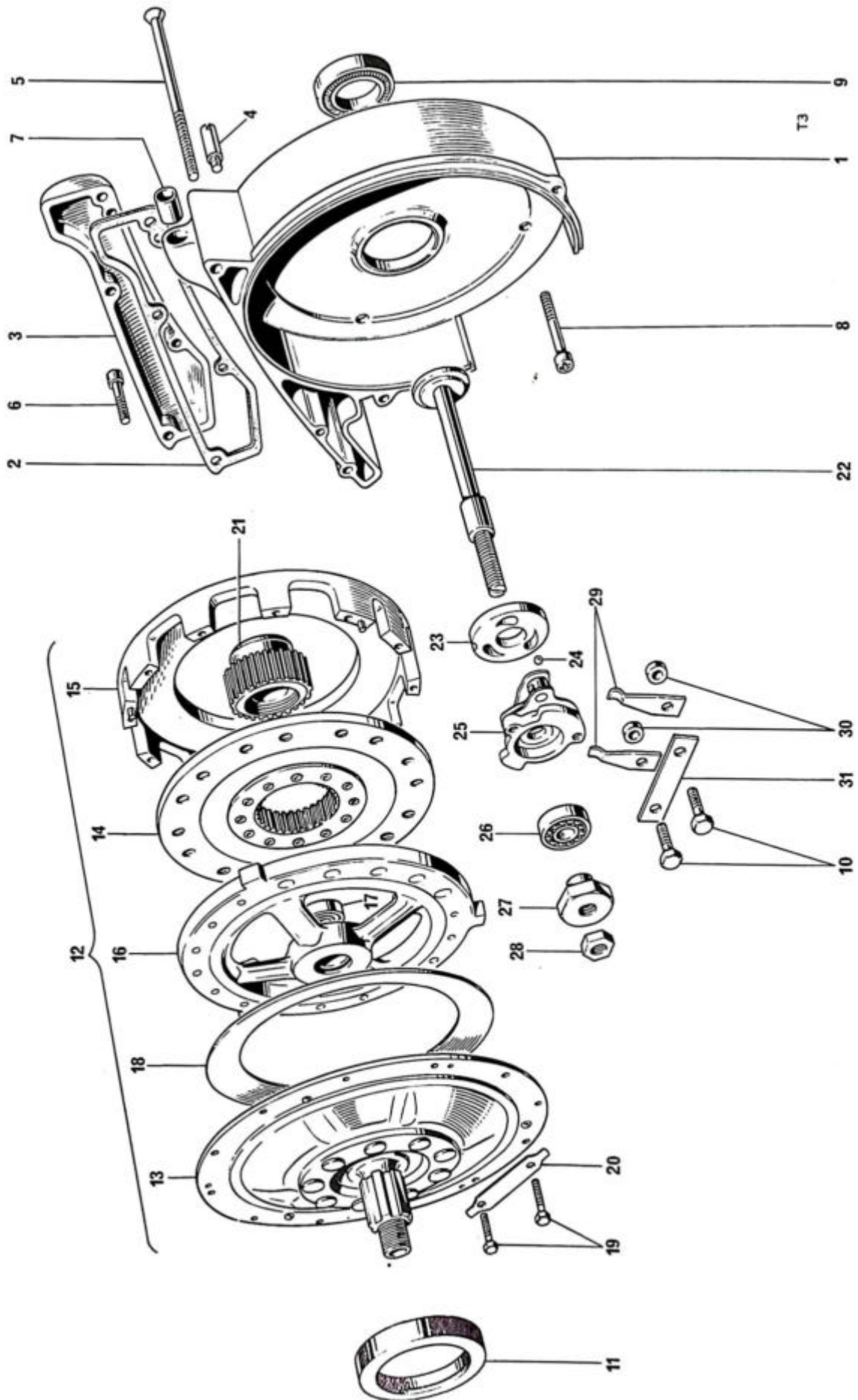

Fig. 13. CLUTCH AND CLUTCH OPERATING MECHANISM

Ref. No.	Part No.	DESCRIPTION	QUANTITY	REMARKS
----------	----------	-------------	----------	---------

CLUTCH AND CLUTCH OPERATING MECHANISM

1	T2554	Clutch cover	1	
2	E11452	Joint washer	1	
3	T2555	Cover, breather duct	1	
4	T3756	Adaptor	1	
5	14-6515	Screw, long, cover to crankcase (4 in. U.H.)	1	
6	S680	Screw, short, cover to crankcase ($\frac{1}{8}$ in.)	3	
7	T2557	Tube	1	
8	14-6610	Screw cover to crankcase	3	
9	T3642	Oil seal cover to mainshaft	1	
10	14-6102	Bolt	2	
11	T3642	Oil seal clutch shaft	1	
12	T2562	CLUTCH ASSEMBLY (BORG & BECK 76183)	1	
13	T3705	End cover, assembly (BORG & BECK 76169)	1	
14	T3709	Driven plate assembly (BORG & BECK 53273)	1	
15	T3708	Drive ring (BORG & BECK 76167)	1	
16	T3715	Pressure plate (BORG & BECK 76184)	1	
17	T3717	Thrust bearing (BORG & BECK 76168)	1	
18	T3718	Diaphragm spring red (BORG & BECK 75303/13)	1	
19	T3719	Bolt end cover to housing (BORG & BECK K26904)	12	
20	T3720	Tab washer, end cover to housing (BORG & BECK 76170)	6	
21	T2580	Clutch hub	1	
22	T2552	Pull rod clutch release	1	
23	T2465	Thrust plate inner	1	
24	D2364	Ball, $\frac{1}{4}$ in. dia.	3	
25	T2547	Clutch lever complete	1	
26	T3647	Bearing, outer thrust plate	1	
27	T2553	Sleeve nut	1	
28	14-0402	Locknut	1	
29	T2473	Spring, outer thrust plate	2	
30	T3638	Distance piece, outer thrust plate	2	
31	T2474	Tab washer	1	

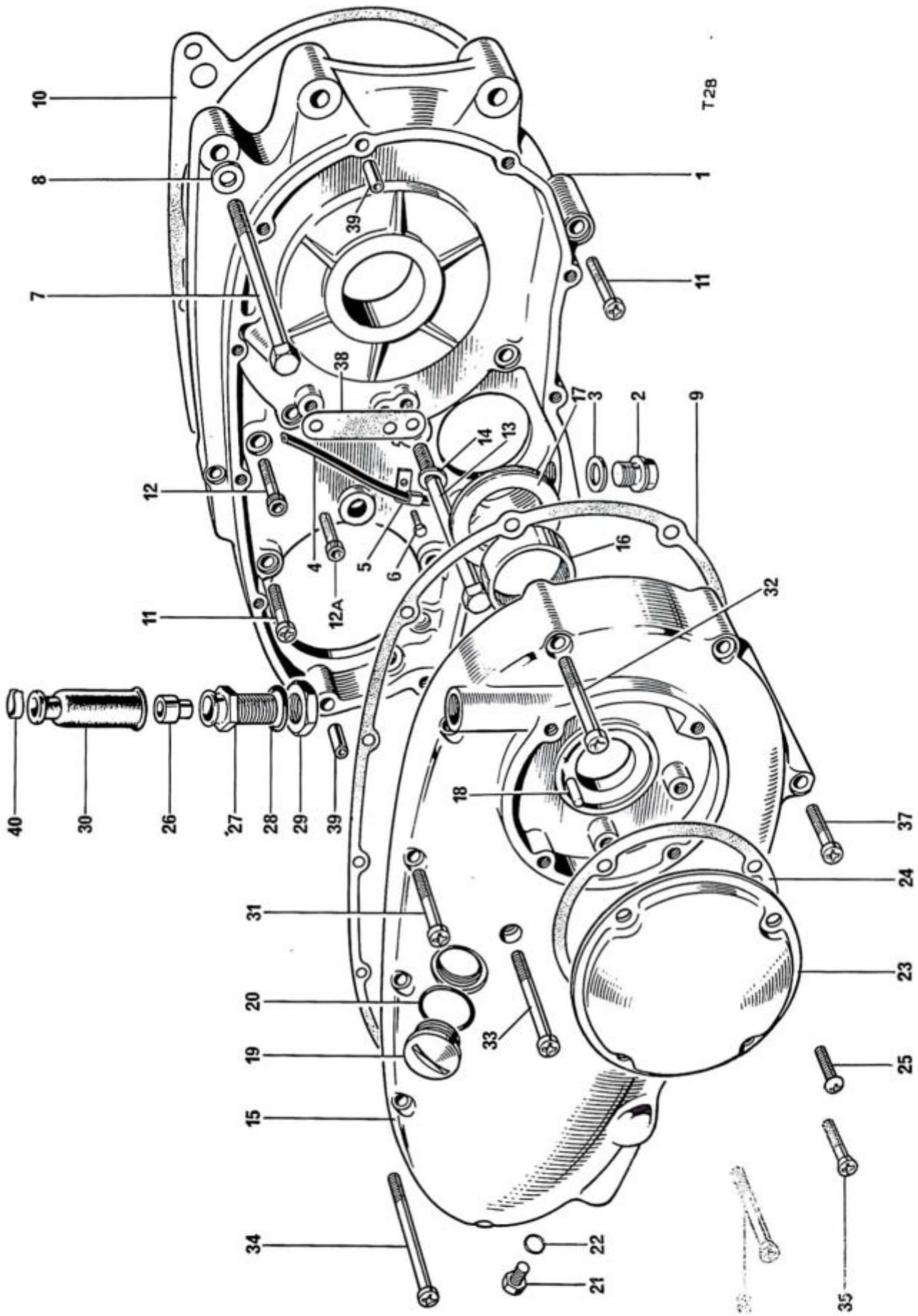

FIG. 14. INNER AND OUTER CHAINCASE

Ref. No.	Part No.	DESCRIPTION	QUANTITY	REMARKS
INNER AND OUTER CHAINCASE				
1	T4018	Inner primary chaincase	1	
2	S536	Drain plug	1	
3	E402	Washer	1	
4	E8786	Tube, chain oiler	1	
5	E4705	Clip, chain oiler—tube	1	
6	14-6101	Bolt, clip...	1	
7	S1820	Bolt, long	1	
8	S25-3	Washer	1	
9	E11454	Gasket inner to outer chaincase	1	
10	E11453	Gasket inner case to crankcase	1	
11	14-6606	Screw, short	2	
12	14-7006	Socket screw	7	
12A	14-7004	Socket screw	1	
13	S1819	Bolt	1	
14	S25-3	Washer	1	
15	T3958	OUTER PRIMARY CHAINCASE	1	
16	T3643	Needle roller bearing	1	
17	T2215	Thrust washer	1	
18	T912	Peg, thrust plate	1	
19	T2166	Filler plug	1	
20	E8782	"O" ring	1	
21	T2259	Tensioner adjuster plug	1	
22	T3733	"O" ring	1	
23	T3954	Inspection cover	1	
24	E11449	Inspection cover gasket	1	
25	14-6605	Screw, inspection cover	4	
26	T2220	Clutch cable abutment	1	
27	T1645	Adaptor	1	
28	T3733	Sealing Ring	1	
29	S567	Locknut	1	
30	T1646	Rubber cap	1	
31	14-6611	Screw, outer to inner chaincase	6	
32	14-6612	Screw, outer to inner chaincase	1	
33	14-6613	Screw, long outer to inner chaincase	2	
34	14-6615	Screw, outer to inner chaincase	1	
35	14-6504	Screw, short countersunk	2	
36	14-6509	Screw, longer countersunk	1	
37	14-6610	Screw, short, chaincase	1	
38	E12793	Joint washer	1	
39	T989	Dowel	2	
40	T4194	Clip, clutch cable	1	
Not illus.	D3748	Transfer "5 Speed"	1	

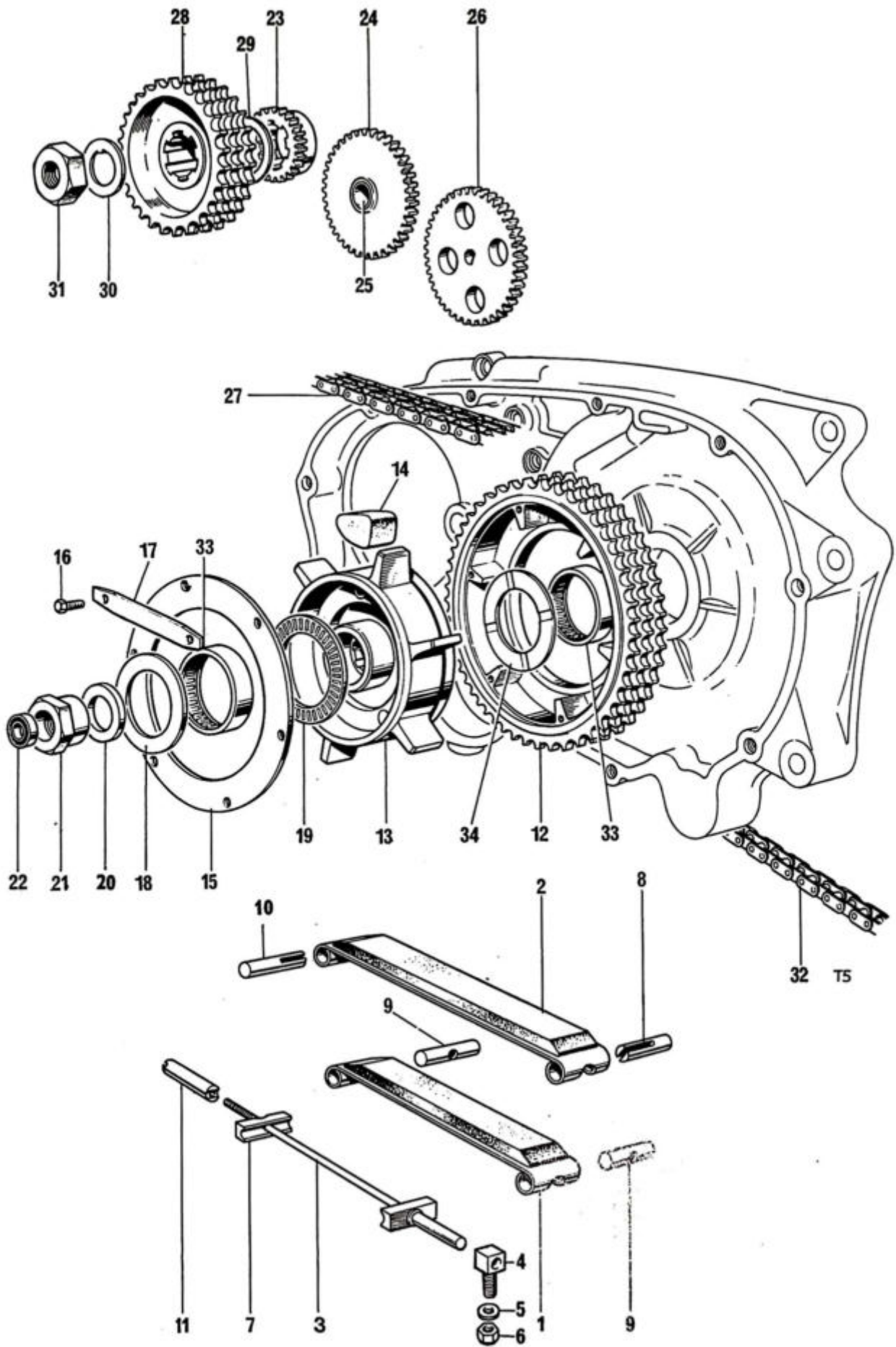

Fig. 15. PRIMARY TRANSMISSION AND OIL PUMP DRIVE

Ref. No. Part No. DESCRIPTION QUANTITY REMARKS

PRIMARY TRANSMISSION AND OIL PUMP DRIVE

1	T3610	Tensioner blade	1	
2	E6061	Tensioner blade	1	
3	T3983	Tie rod	1	
4	T3986	Eye bolt	1	
5	T3987	Washer	1	
6	14-1901	Nut	1	
7	E9258	Saddle washer	2	
8	E9256	Trunnion	1	
9	E5977	Trunnion	2	
10	T3614	Pivot pin...	1	
11	T3617	Adjuster nut	1	
12	T4225	Clutch sprocket (50T)	1	
13	T4621	Spider	1	
14	T4324	Shock absorber rubber	12	
15	T4004	Retaining plate	1	
16	T3940	Bolt, retaining plate	6	
17	T3941	Tab washer	3	
18	T2215	Outer thrust washer, clutch shaft	1	
19	T3646	Thrust race	1	
20	T2478	Spacer, shock absorber nut	1	
21	T2480	Nut	1	
22	T3644	Oil seal	1	
23	E7248	Driven gear	1	
24	E7246	INTERMEDIATE GEAR C/W BUSH	1	
25	E6885	Bush	1	
26	*E9886	Oil pump driven gear	1	
27	D699	Primary chain, triple row, 82 links	1	
28	E6890	Engine sprocket (28T)	1	
29	E8038	Shim, engine sprocket (0-010 in. thick)	as required	
29	E12660	Shim, engine sprocket (0-030 in. thick)	as required	
30	E8785	Tab washer	1	
31	S585	Nut, engine sprocket	1	
32	D2118	Rear chain 107 links	1	
33	T3643	Needle race	2	
34	T2214	Thrust washer, inner	1	

*Also listed on page 13.

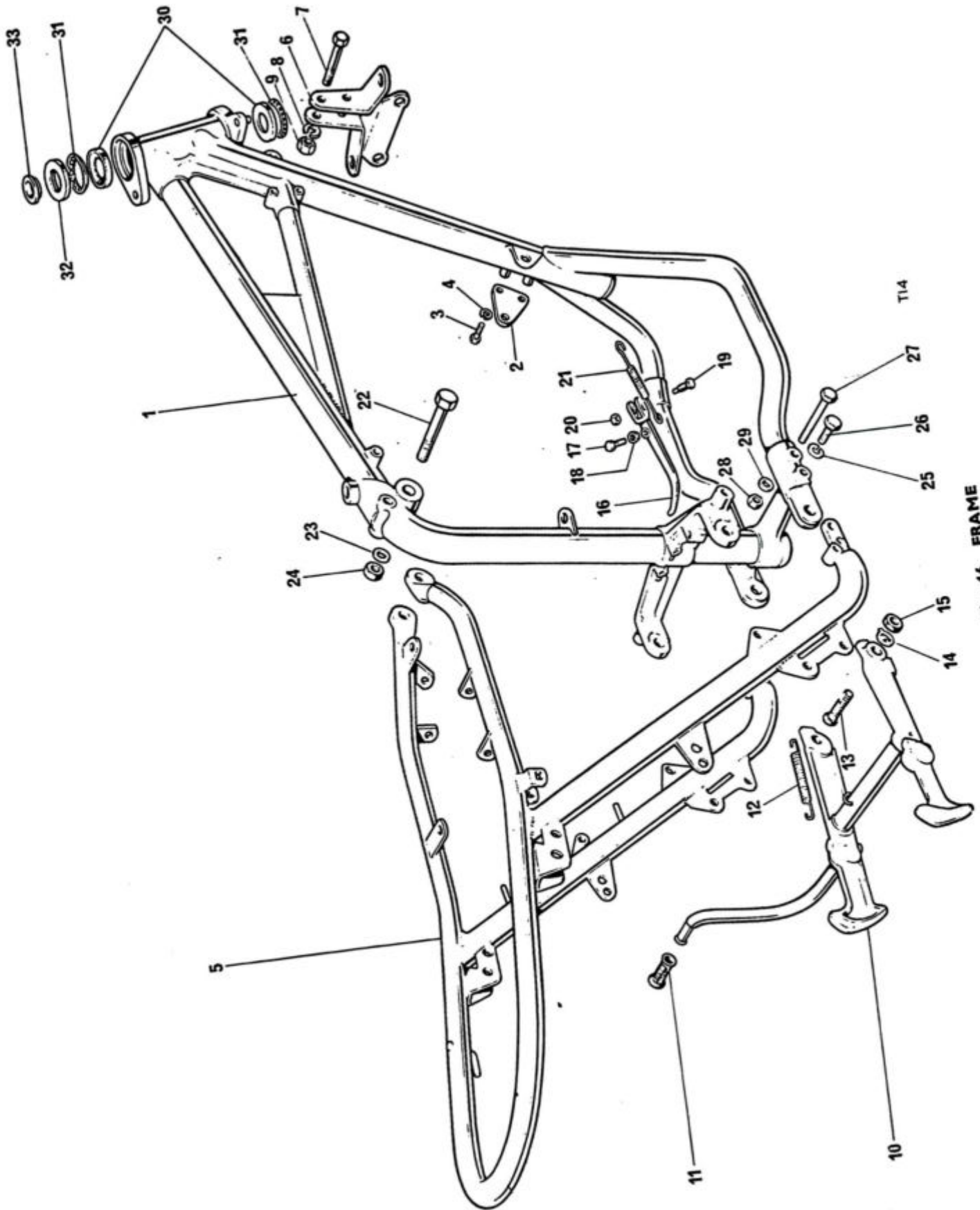

Fig. 16. FRAME

Ref. No.	Part No.	DESCRIPTION	QUANTITY	REMARKS
FRAME				
1	F13218	Front Frame	1	
Not illus.	F7155	Lock stops	2	
2	F7159	Front D.S. engine plate	1	
3	14-0126	Bolt	2	
4	S26-1	Spring washer	2	
5	F13219	Rear frame	1	
6	F12024	Mounting bracket, petrol tank	1	
7	S1805	Bolt	2	
8	S26-3	Washer	2	
9	14-0402	Nut	2	
10	F11267	Centre stand	1	
11	T2331	Pedal rubber	1	
12	F4671	Spring	1	
13	S1978	Pivot bolt	2	
14	F11270	Tab washer	2	
15	14-0404	Nut	2	
16	F11560	Prop stand	1	
17	14-0113	Bolt	1	
18	14-0402	Nut	1	
19	F7021	Swivel pin	1	
20	14-0703	Nut, swivel pin	1	
21	F8382	Spring	1	
22	14-0241	Bolt, top rear to front frame	1	
23	S25-2	Washer	2	
24	14-1303	Nut	1	
25	99-0046	Spring Washer	2	
26	S588	Bolt, bottom rear to front frame	2	
27	14-0251	Bolt, front rear to front frame	2	
28	14-1304	Nut	2	
29	F4370	Washer	2	
30	H111	Cup, top and bottom steering race	2	
31	H4034	Steering head race	2	
32	H1018	Top cone (c/w dust cover)	1	
33	H4145	Steering stem collar (top)	1	
Not illus.	D2452	Transfer "Safety Standards"	1	

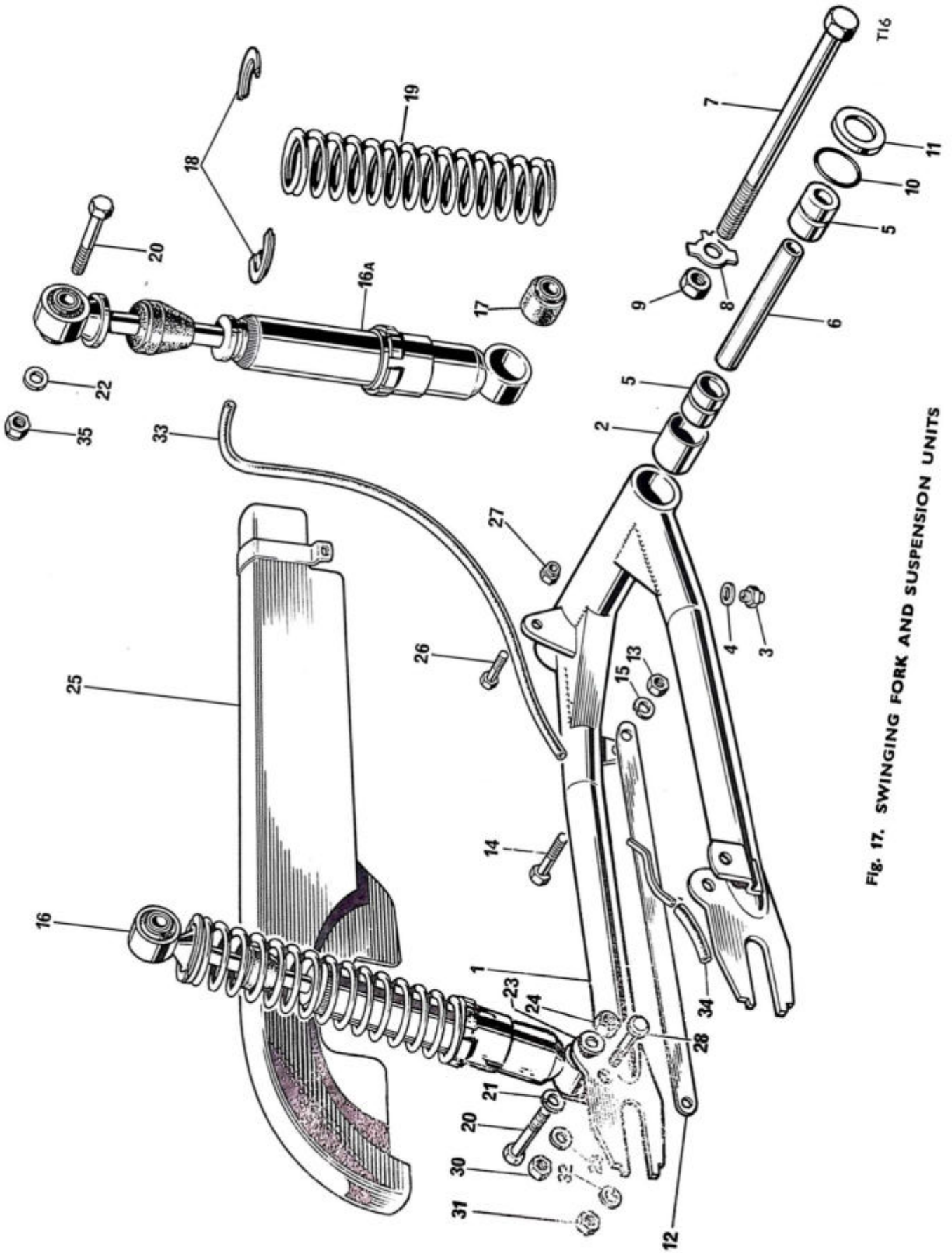

Fig. 17. SWINGING FORK AND SUSPENSION UNITS

Ref. No. Part No. DESCRIPTION QUANTITY REMARKS

SWINGING FORK AND SUSPENSION UNITS

1	F13233	SWINGING FORK	1	
2	F6042	Bush	2	
3	D1841	Grease nipple	1	
4	WE170	Fibre washer	1	
5	F6821	Bobbin	2	
6	F5313	Distance tube	1	
7	S620	S/arm bolt	1	
8	F5944	Tab washer	1	
9	S545	Nut	1	
10	F8090	"O" ring	2	
11	F7848	Oil seal housing	2	
12	F13228	Torque stay	1	
13	14-1304	Nut	1	
14	14-0133	Bolt	1	
15	99-0046	Spring washer	1	
16	D2294	SUSPENSION UNIT 64052341	2	
16a	64052090	Damper unit		Reference only
17	64533645	Bonded bush (99-0122)	4	
18	9054/171	Spring retainer (99-0107)	4	
19	64544754	Spring (110 lbs.) (99-1139)	2	
20	14-0235	Bolt, top and bottom	4	
21	D2429	Spring washer - D.S. lower	1	
22	S25-2	Washer,	7	
23	F2184	Washer—D.S. lower	1	
24	14-1303	Nut	2	
25	F13231	Rear chainguard	1	
26	14-0113	Front pivot bolt	1	
27	14-0702	Self-locking nut	1	
28	F9387	Bolt, rear chainguard to fork ($\frac{35}{32}$ in.)	1	
29	D2331	Washer	1	
30	14-1302	Nut	1	
31	14-1304	Nut	1	
32	S25-71	Washer	1	
33	F7352	Chain oiler pipe—long	1	
34	F9997	Chain oiler pipe—short	1	
35	14-1303	Nut	2	

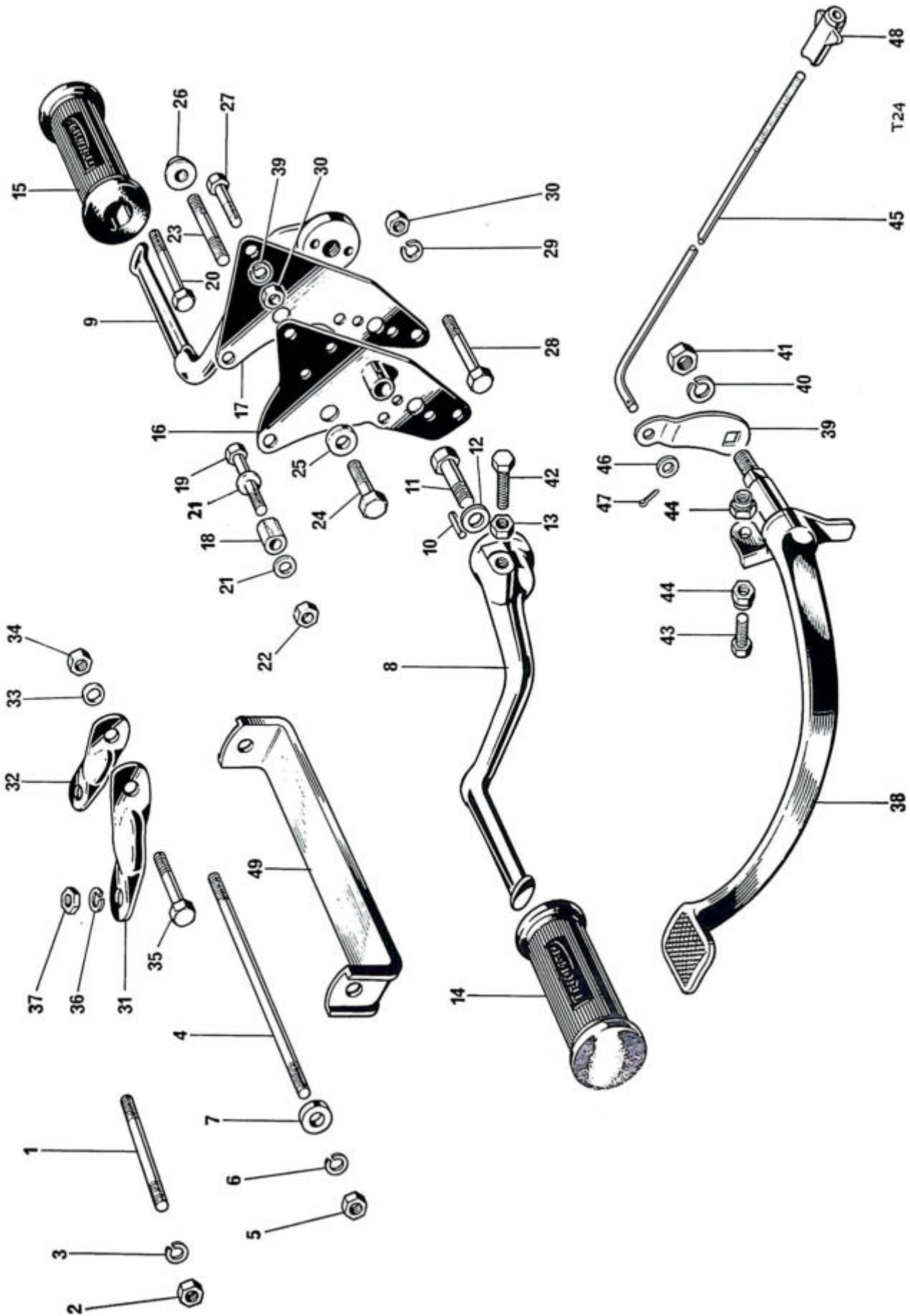

Fig. 18. MOTOR UNIT FITTINGS AND FOOTRESTS

Ref. No.	Part No.	DESCRIPTION	QUANTITY	REMARKS
MOTOR UNIT FITTINGS AND FOOTRESTS				
1	14-6254	Bolt, front engine to frame	1	
2	14-1304	Nut, stud.	1	
3	D2323	Spring washer	2	
4	S572	Stud (bottom) engine to frame (10½ in. O.A.)	1	
5	14-0304	Nut, stud	2	
6	99-0046	Spring washer	2	
7	F5532	Spacer, bottom engine fixing	1	
8	F9623	Drive side footrest	1	
9	F9624	Timing side footrest	1	
10	F5943	Peg	4	
11	S1969	Bolt, footrest	2	
12	F8243	Washer, footrest stud	2	
13	14-0401	Locknut	1	
14	F9279	Footrest rubber D.S.	1	
15	F9630	Footrest rubber T.S.	1	
16	F11597	Rear engine plate D.S.	1	
17	F11594	Rear engine plate T.S.	1	
18	F11598	Spacer D.S. rear engine plate	2	
19	14-0222	Bolt, D.S. rear engine plate to engine	2	
20	14-0221	Bolt, T.S. rear engine plate to engine	2	
21	S25-3	Washer, rear engine plate to engine	8	
22	14-1302	Nut	4	
23	S548	Stud, T.S. pivot lug to engine plate (1⅜ in. O.A.)	1	
24	14-0132	Bolt, D.S. pivot lug to engine plate	1	
25	F3770	Washer	1	
26	F7389	Nut	2	
27	14-0128	Bolt, upper rear engine plate to frame	2	
28	14-0234	Bolt, lower rear engine plate to frame	2	
29	D2322	Spring washer	4	
30	14-1303	Nut	4	
31	F9378	Torque stay engine L.H.	1	
32	F9378	Torque stay engine R.H.	1	
33	S25-2	Washer	2	
34	14-1303	Nut	2	
35	14-0237	Bolt, torque stay to frame	1	
36	D2321	Washer	2	
37	14-1302	Nut	1	
38	F13224	Rear brake pedal	1	
39	F6064	Lever	1	
40	D2322	Spring washer	1	
41	14-1303	Nut	1	
42	14-0105	Stop bolt... ..	1	
43	14-0103	Adjuster, stoplamp switch	1	
44	14-0401	Nut, adjuster	2	
45	F13227	Brake rod	1	
46	F14277	Distance piece	1	
47	—	Split pin, (⅜ in. x ⅜ in.)	1	Reference only
48	F7387	Adjuster nut	1	
49	F9529	Oil pipe retaining strap	1	

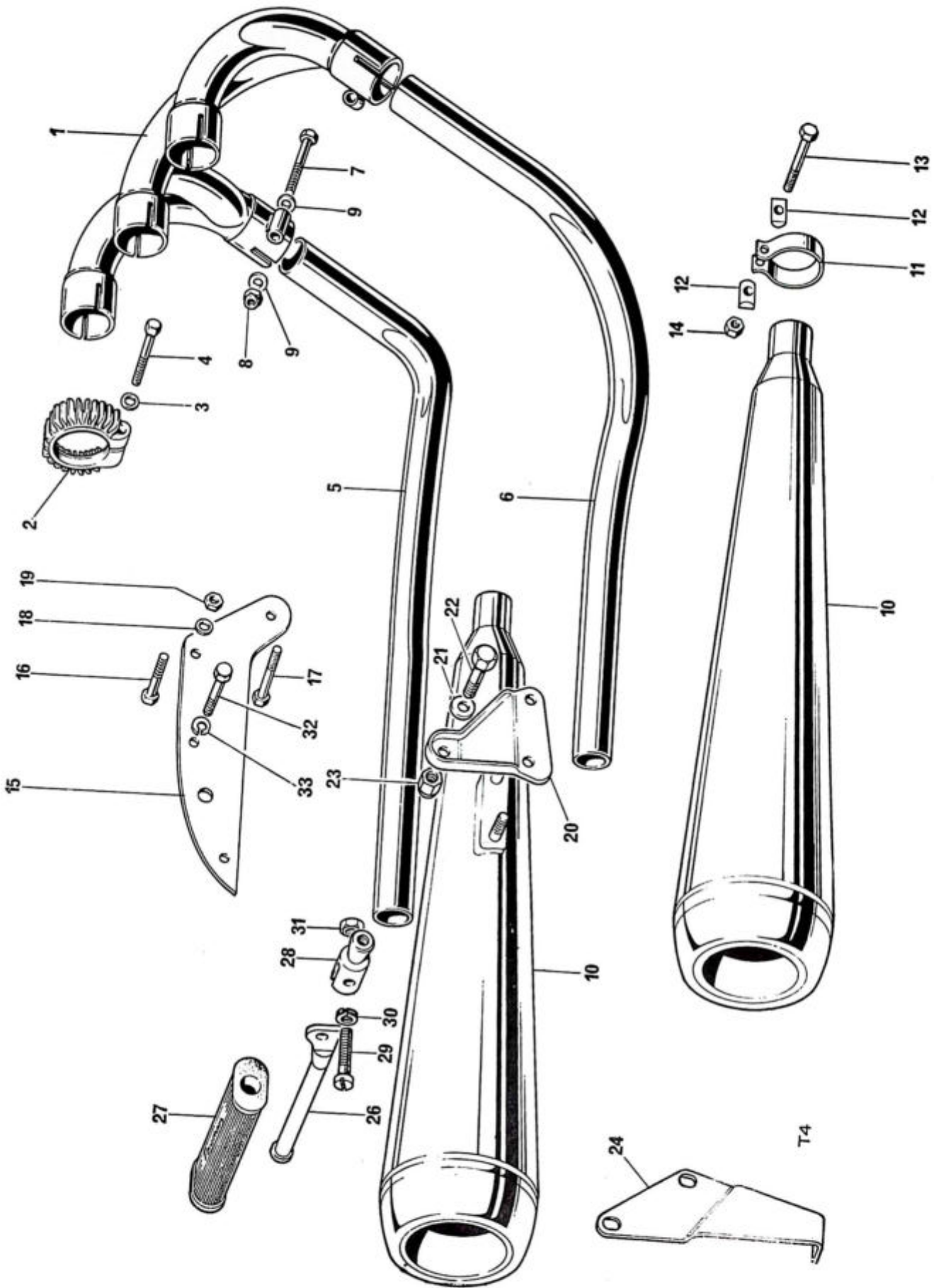

Fig. 19. EXHAUST PIPES AND MUFFLERS

Ref. No. Part No. DESCRIPTION QUANTITY REMARKS

EXHAUST PIPES AND MUFFLERS

Ref. No.	Part No.	DESCRIPTION	QUANTITY	REMARKS
1	E7597	Exhaust manifold	1	
2	E6743	Finned clip	3	
3	E410A	Hemispherical washer	3	
4	E6744	Bolt	3	
5	E12451	Exhaust pipe—D.S.	1	
6	E12453	Exhaust pipe—T.S.	1	
7	14-0205	Bolt } Exhaust pipe to manifold	2	
8	14-1201	Nut } Exhaust pipe to manifold	2	
9	S25-1	Washer } Exhaust pipe to manifold	4	
10	E12382	Muffler	2	
11	E7512	Clip } Muffler to exhaust pipe	2	
12	E3768	'D' washer } Muffler to exhaust pipe	4	
13	14-0219	Bolt } Muffler to exhaust pipe	2	
14	14-1302	Nut } Muffler to exhaust pipe	2	
15	E4711	Hanger	2	
16	14-0115	Bolt } Hanger to frame	2	
17	14-0116	Bolt } Hanger to frame	2	
18	S25-3	Washer } Hanger to frame	4	
19	14-1302	Nut } Hanger to frame	4	
20	E12460	Bracket—D.S.	1	
20	E11848	Bracket—T.S.	1	
21	S25-13	Washer } Bracket to muffler	4	
22	14-0101	Bolt } Bracket to muffler	4	
23	14-1201	Nut } Bracket to muffler	4	
24	F12033	Centre stand stop plate	1	
25	F9369	PILLION FOOTREST	2	
26	F1694	Pedal	1	} Each assembly
27	F1695	Rubber	1	
28	F9370	Hanger	1	
29	F9371	Pivot bolt	1	
30	F2277	Thackeray washer	1	
31	14-0302	Nut	1	
32	S1910	Bolt	1	
33	S26-1	Spring washer	1	

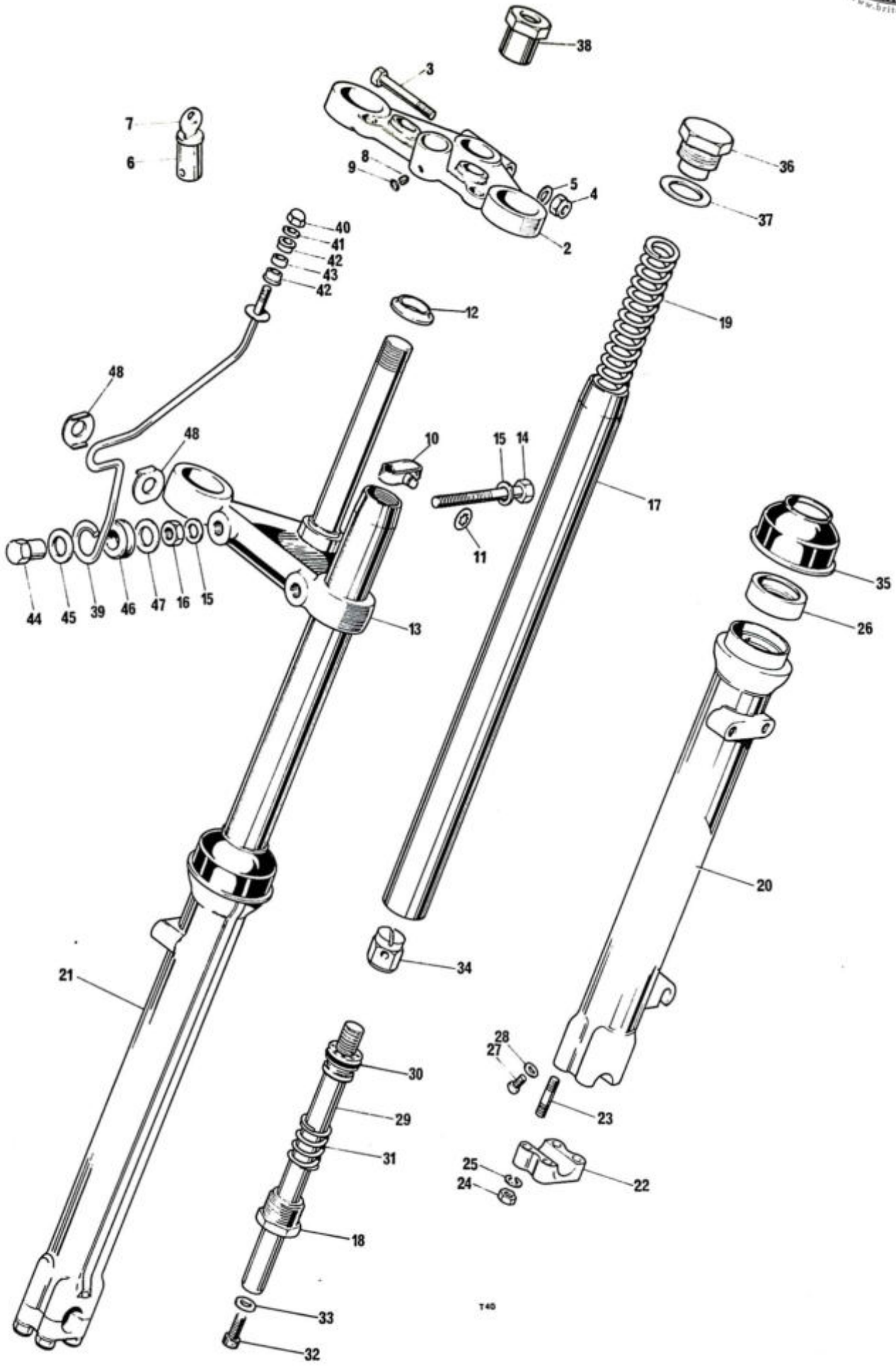

Fig. 20. TELESCOPIC FRONT FORK

Ref. No.	Part No.	DESCRIPTION	QUANTITY	REMARKS
TELESCOPIC FRONT FORK				
1	H4245	FORK ASSEMBLY	1	
2	H4035	Top yoke	1	
3	14-0234	Pinch bolt	1	
4	14-1303	Nut	1	
5	S25-2	Washer	1	
6	F6738	Lock c/w 2 keys	1	
7	D623	Key (state serial No.)	1	
8	S578	Grub screw	1	
9	H2266	Sealing washer	1	
10	F3098	Brake cable retainer	1	
11	F8245	Starlock washer	1	
12	H439	Bottom cone	1	
13	H4321	Bottom yoke and stem	1	
14	14-0238	Pinch bolt	2	
15	S25-2	Washer	4	
16	14-1303	Nut	2	
17	H4007	Stanchion	2	
18	H4076	End plug	2	
19	H4215	Main spring	2	
20	H4343	Outer member—R.H.	1	
21	H4342	Outer member—L.H.	1	
22	H3947	Cap wheel spindle	2	
23	S2102	Stud	8	
24	14-0302	Nut	8	
25	D2428	Washer	8	
26	H4001	Oil seal outer member	2	
27	H3894	Drain plug	2	
28	H3893	Washer	2	
29	H4324	Damper tube and valve assembly	2	
30	H4003	"O" ring—damper valve	2	
31	H4009	Recoil spring	2	
32	14-1019	Cap screw—damper tube	2	
33	H4004	Cap screw seal	2	
34	H4244	Nut—damper valve	2	
35	H4002	Scraper sleeve outer member	2	
36	H4309	Top cap nut	2	
37	H4166	Washer	2	
38	H4323	Steering stem nut	1	
39	H4162	Headlamp bracket—L.H.	1	
39	H4163	Headlamp bracket—R.H.	1	
40	S1809	Nut	2	
41	D2338	Washer	2	Headlamp bracket top fixing
42	F12209	Bush	4	
43	F12211	Spacer	2	
44	S2062	Sleeve nut	2	Headlamp bracket bottom fixing
45	D2333	Washer	2	
46	D2630	Grommet	2	
47	F9046	Washer	2	
48	F12216	Clamp washer	4	

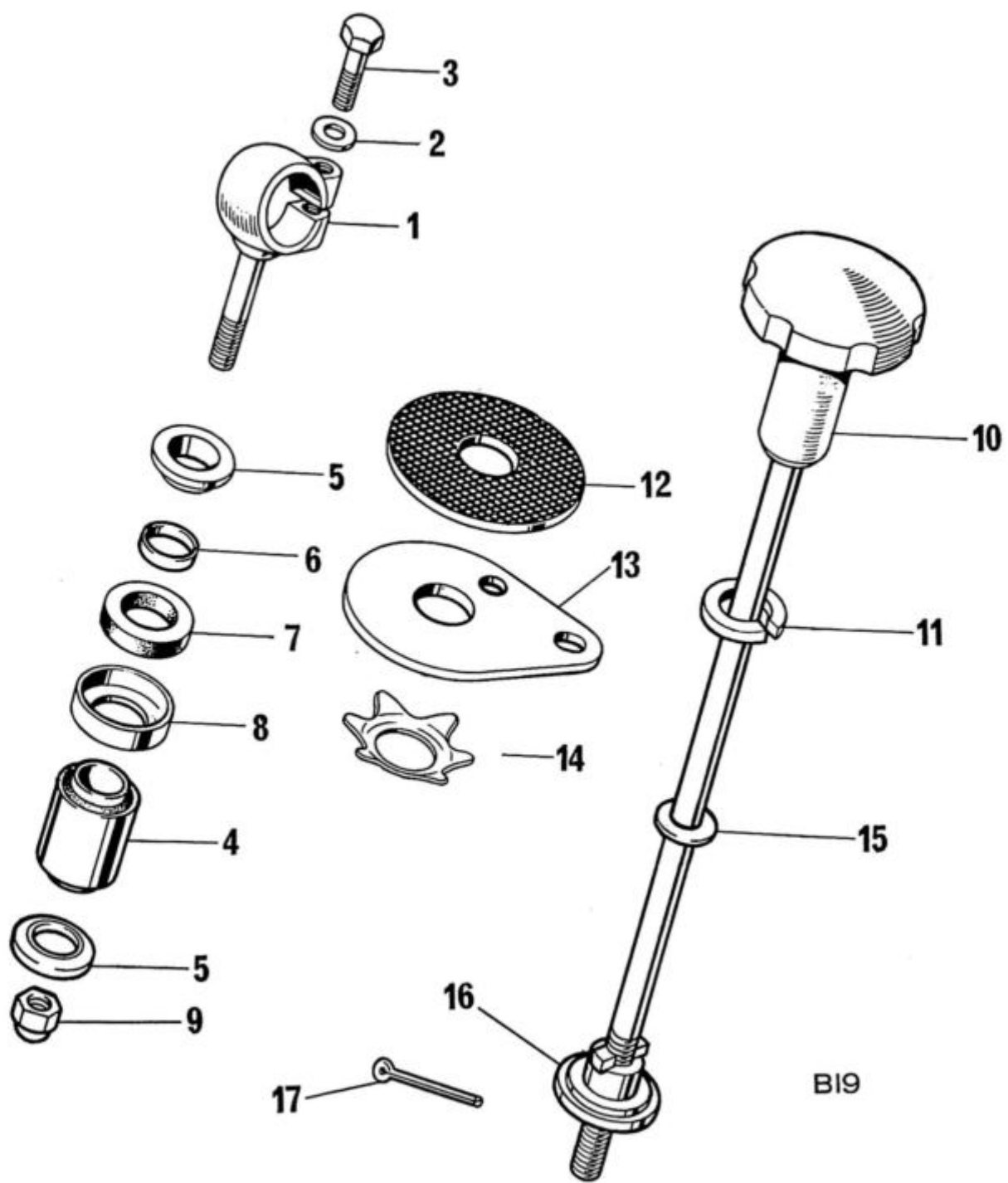

Fig. 21. HANDLEBAR MOUNTINGS AND STEERING DAMPER

Ref. No. Part No. DESCRIPTION QUANTITY REMARKS

HANDLEBAR MOUNTINGS AND STEERING DAMPER

1	H2291	Handlebar eyebolt	2	
2	F1335	Washer	2	
3	S589	Bolt	2	
4	H1527	Metalastic bush	2	
5	H1529	Hemispherical washer	4	
6	H1581	Distance piece	2	
7	H1580	Rubber washer	2	
8	H2221	Cup	2	
9	14-1303	Nut	2	
10	H3875	Steering damper rod c/w knob	1	
11	D2438	Spring washer	1	
12	H435	Friction disc	1	
13	H1797	Anchor plate	1	
14	H95	Spring plate	1	
15	D2329	Washer	1	
16	H4102	Bottom nut	1	
17	—	Split pin ($\frac{3}{32} \times \frac{1}{2}$)		Reference only

FRONT WHEEL COMPLETE No1

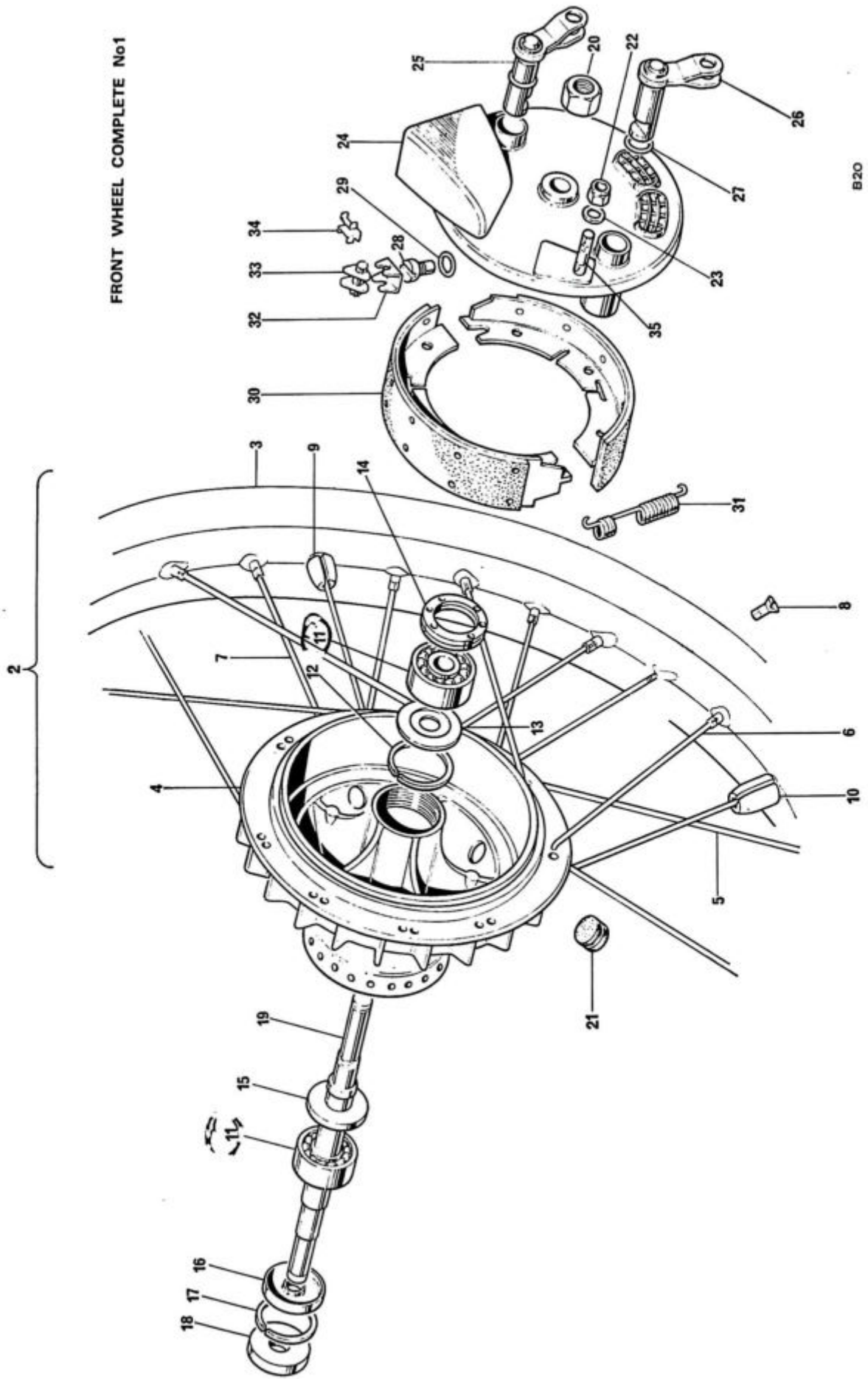

B20

Fig. 22. FRONT WHEEL

Ref. No.	Part No.	DESCRIPTION	QUANTITY	REMARKS
FRONT WHEEL				
1	W3904	FRONT WHEEL COMPLETE	1	
2	W3844	RIM, SPOKES AND HUB ASSEMBLY	1	
3	W3818	Wheel rim (WM2-19)	1	
4	W3658	Brake drum and hub	1	
5	W3820	Spoke (R.H. inner)	10	
6	W3819	Spoke (R.H. outer)	10	
7	W3821	Spoke (L.H.)	20	
8	W2294	Nipple	40	
9	W3969	Balance weight (short)	As required	
10	W3970	Balance weight (long)	As required	
11	W653	Bearing	2	
12	D2632	Circlip R.H.	1	
13	W3797	Grease Retainer R.H.	1	
14	W3759	Lock ring R.H.	1	
15	W1481	Grease cap inner L.H.	1	
16	W1237	Grease cap outer L.H.	1	
17	T280	Circlip L.H.	1	
18	W3932	Distance piece	1	
19	W3796	Wheel spindle	1	
20	W2058	Nut wheel spindle	1	
21	D3669	Grommet brake drum	1	
22	14-1303	Nut	1	} Anchor plate to fork leg
23	D2340	Washer	1	
24	W3655	Brake anchor plate	1	
25	W3987	Brake lever front	1	
26	W3986	Brake lever rear	1	
27	D2639	"O" ring—brake cam	2	
28	W3762	Tappet brake cam	2	
29	W3761	"O" ring—brake tappet	2	
30	W3713	Brake shoe complete	2	
31	W3714	Return spring	2	
32	W3715	Cage brake shoe adjuster	2	
33	W3716	Micram adjuster	2	
34	W3717	Abutment pressing	2	
35	14-1635	Stud—anchor plate torque reaction	1	

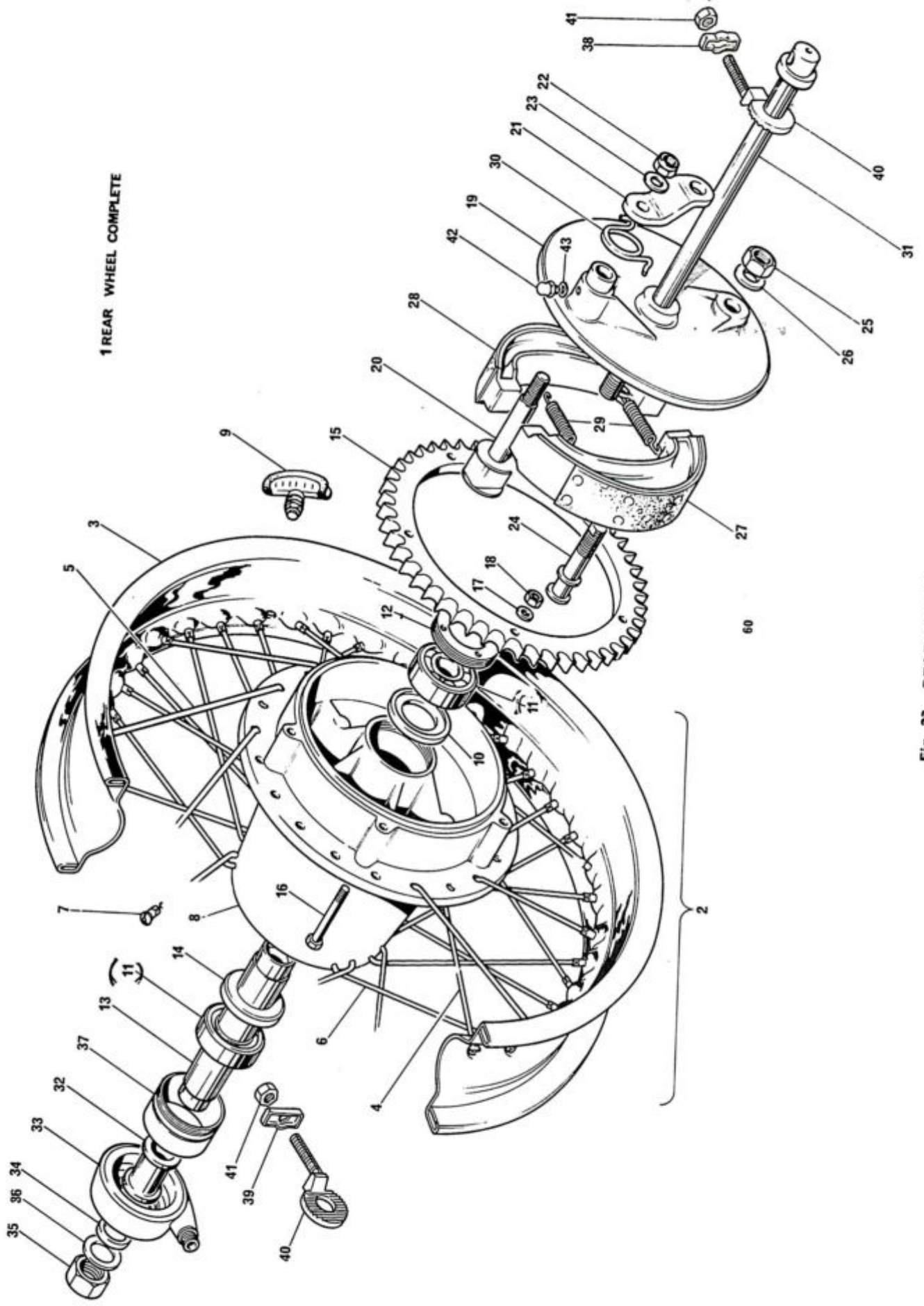

Fig. 23. REAR WHEEL

Ref. No.	Part No.	DESCRIPTION	QUANTITY	REMARKS
REAR WHEEL				
1	W3954	REAR WHEEL COMPLETE	1	
2	W3900	RIM SPOKES AND HUB ASSEMBLY	1	
3	W3920	Rim (WM 3 x 19)	1	
4	W3921	Spoke (inner—L.H.)	1	
5	W3922	Spoke (outer—L.H.)	10	
6	W3923	Spoke—R.H.	20	
7	W2294	Nipple	40	
8	W3773	Hub and brake drum	1	
9	W3468	Tyre security bolt	2	
10	W3749	Support ring—L.H.	1	
11	W653	Bearing	2	
12	W3752	Locking ring—L.H.	1	
13	W3753	Spacer	1	
14	W1654	Grease retainer—R.H.	1	
15	W3903	Sprocket 53 teeth	1	
15	W4046	Sprocket—50 teeth	Alternative	
16	14-0207	Bolt	5	} Sprocket to hub
17	D2320	Washer	5	
18	14-1301	Nut	5	
19	W3856	Brake anchor plate	1	
20	W3872	Brake cam	1	
21	W4034	Brake lever	1	
22	14-1303	Nut	1	
23	D2331	Washer	1	
24	W3870	Brake pivot	1	
25	14-0305	Nut	} Brake pivot to torque arm	1
26	D2431	Washer		
27	W3925	Brake shoe complete (leading)	1	
28	W3926	Brake shoe complete (trailing)	1	
29	W2328	Return spring (brake shoe)	2	
30	W4049	Return spring (brake lever)	1	
31	W3980	Wheel spindle	1	
32	W3750	Distance piece inner	1	
33	D3213	Speedometer drive gearbox	1	
34	W3901	Distance piece outer	1	
35	14-1307	Nut	} Wheel spindle	1
36	W3976	Washer		
37	W3751	Speedometer drive ring	1	
38	W1015	Cover plate—swinging arm fork end—L.H.	1	
39	W3961	Cover plate—swinging arm fork end—R.H.	1	
40	W3919	Chain adjuster	2	
41	14-1902	Nut—chain adjuster	2	
42	D1841	Grease nipple	1	
43	WE170	Fibre washer	1	

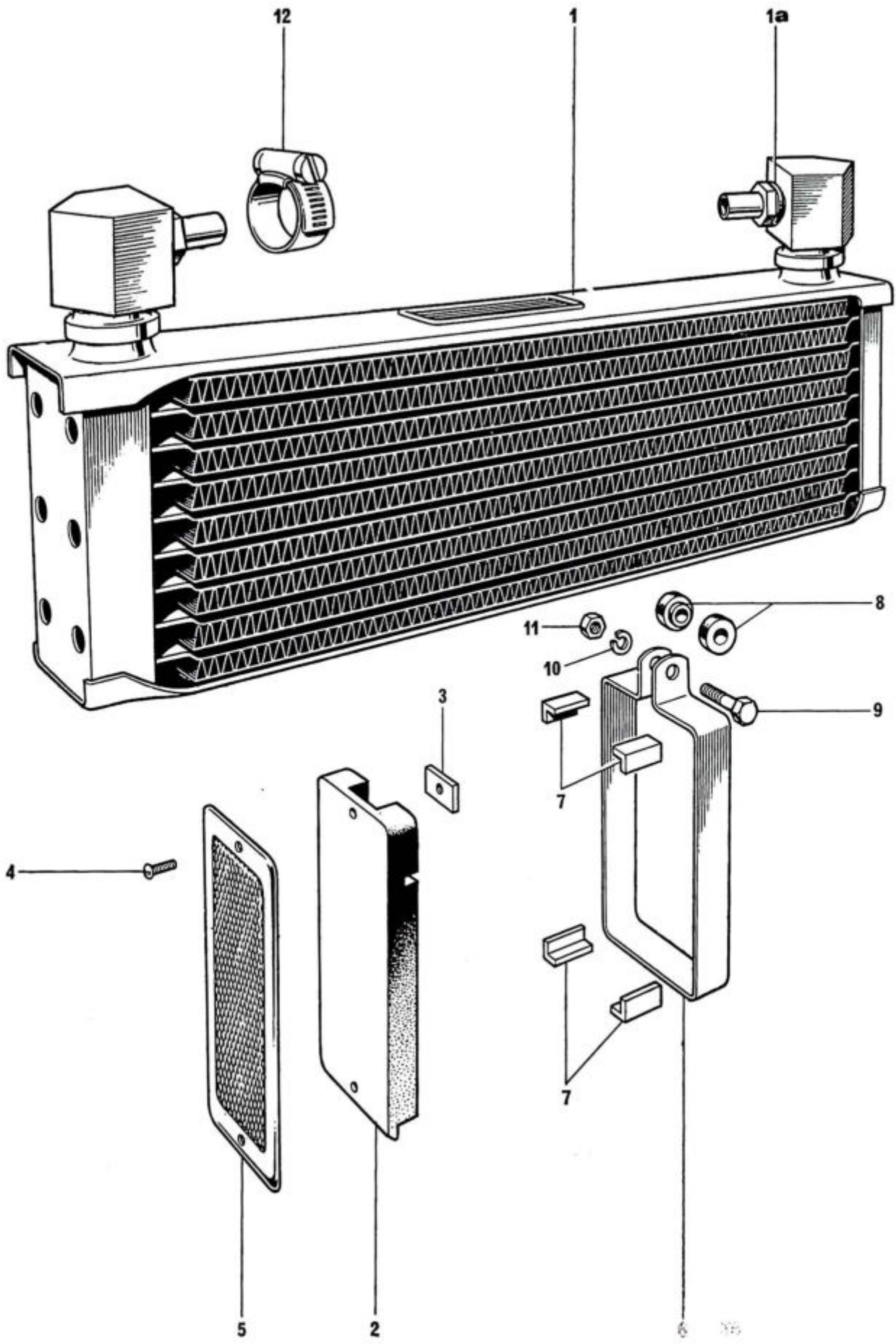

Fig. 24. OIL COOLER

Ref. No.	Part No.	DESCRIPTION	QUANTITY	REMARKS
OIL COOLER GROUP				
1	F9315	Oil cooler, including unions ...	1	
1A	M10441	Washer (Cov. Rad.) ...	Reference only	
2	F9907	Reflector rubber and plate ...	2	
3	F9573	Reflector nut ...	4	
4	S1940	Reflector screw ...	4	
5	57160	Reflector (99-1119) ...	2	
6	F9317	Support strap ...	2	
7	F9322	Corner packing ...	8	
8	F9321	Rubber bush ...	4	
9	F9323	Clamp bolt ($\frac{3}{16}$ in. U.H.) ...	2	
10	E2351	Spring washer ...	2	
11	F4717	Nut ...	2	
12	D702	Clip ...	2	

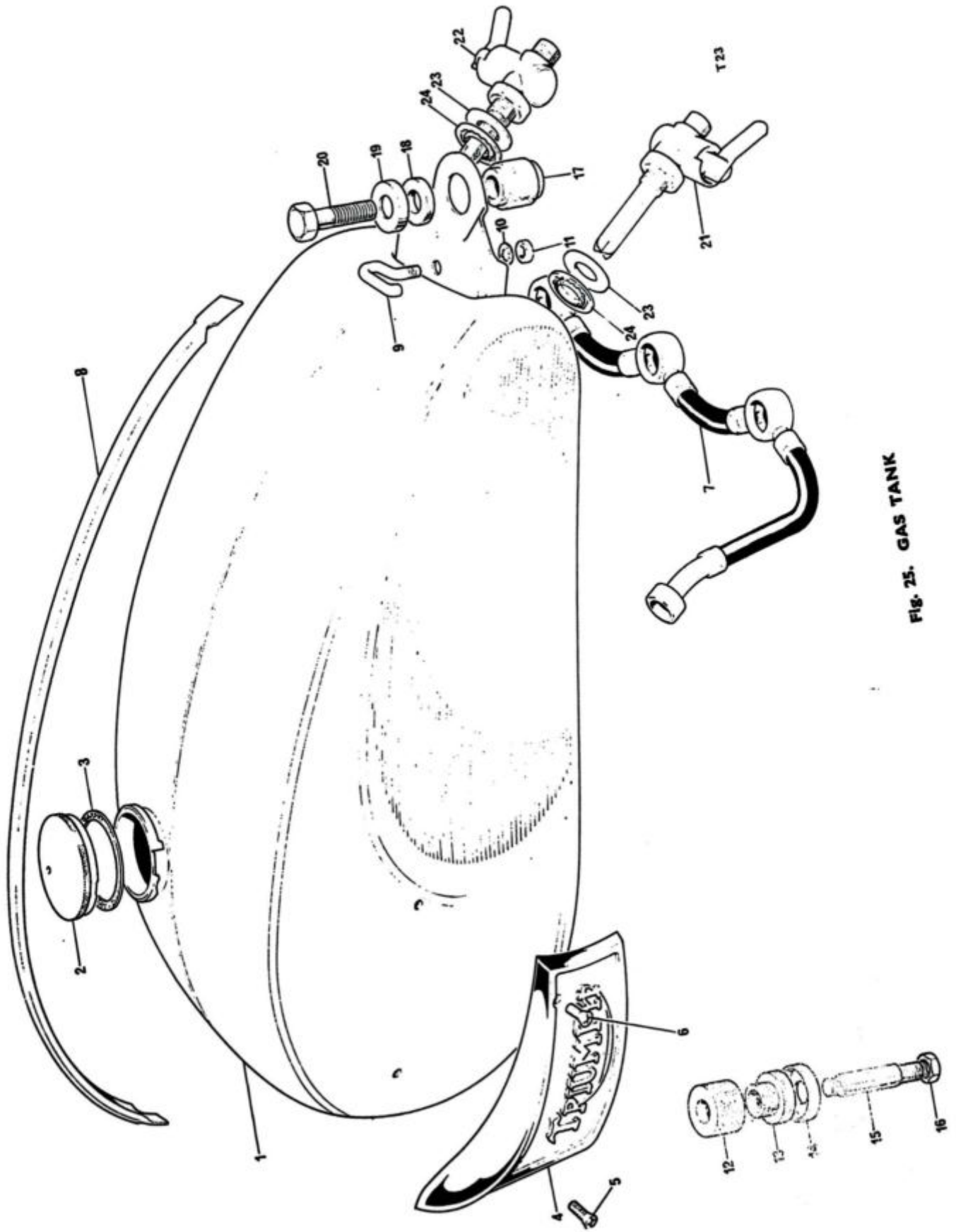

FIG. 25. GAS TANK

Ref. No.	Part No.	DESCRIPTION	QUANTITY	REMARKS
GAS TANK				
1	F14964	Gas tank (4 U.S. galls)	1	
Not illus.	A56	Transfer "World Record Holder"	1	
2	F13875	Filler cap	1	
3	F4048	Joint washer	1	
4	F9701	Styling unit—D.S.	1	
4	F9700	Styling unit—T.S.	1	
5	F11339	Screw—front } Styling unit to tank	2	
6	F7888	Screw—rear } Styling unit to tank	2	
7	F13154	Gas pipe	1	
8	F12034	Centre band	1	
9	F10008	Hook screw	1	
10	F4019	Washer	1	
11	H919	Nut	1	
12	F5228	Top rubber	2	
13	F9543	Spigotted rubber	2	
14	F3814	Bottom cup	2	
15	S2019	Stud	2	
16	14-1302	Nut	2	
17	F5336	Mounting rubber	1	
18	F967	Rubber washer	1	
19	F3814	Cup	1	
20	F7388	Bolt	1	
21	F12801	Gas tap—reserve	1	
22	F12800	Gas tap	1	
23	F10002	Washer	2	
24	E7351	Tap seal	2	
1	F14872	Gas tank (5 U.S. galls)	Available	

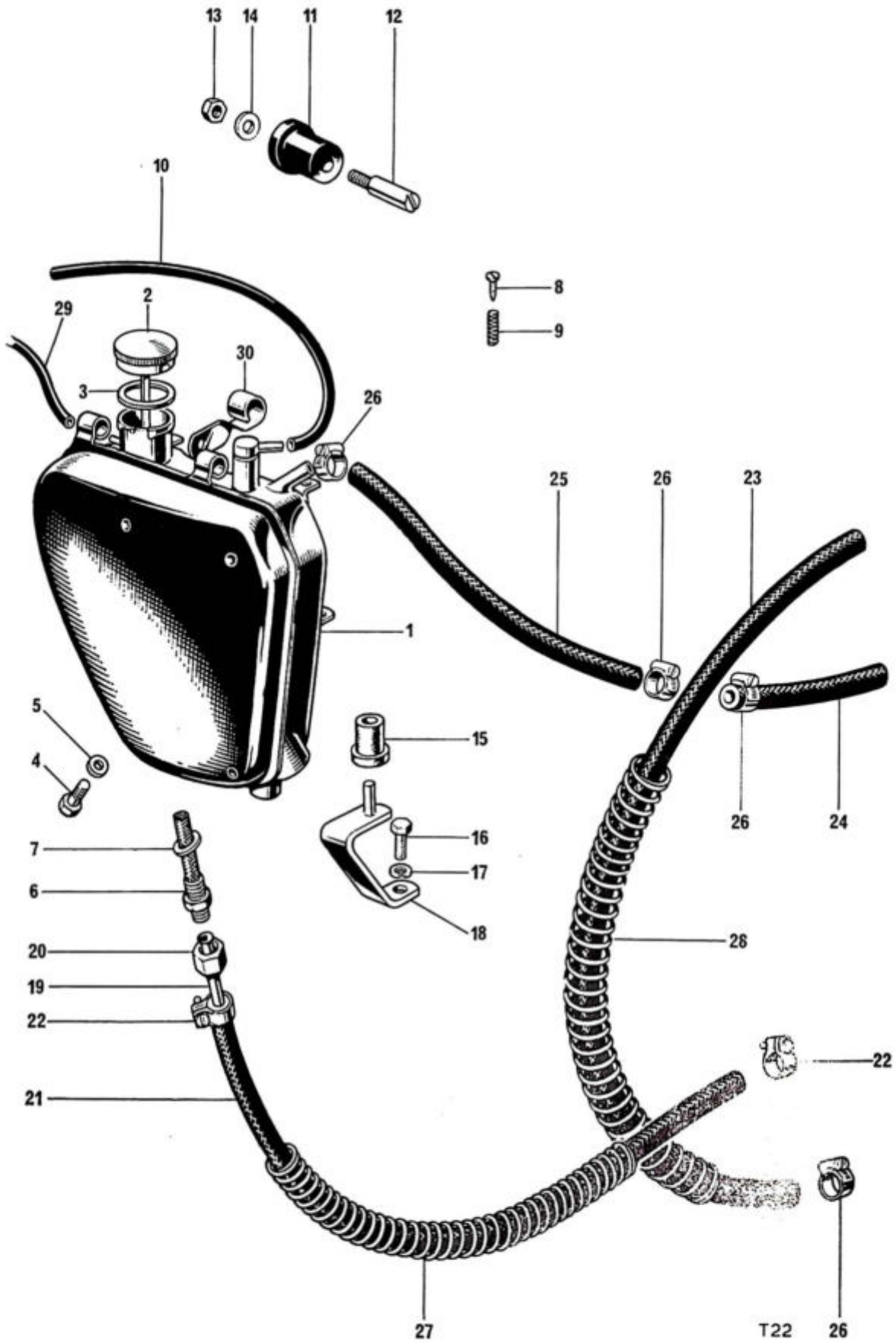

Fig. 26. OIL TANK

Ref. No. Part No. DESCRIPTION QUANTITY REMARKS

OIL TANK

1	F11761	Oil tank	1
Not illus.	A40 (D778)	Transfer (gilt)	1
Not illus.	A44 (D44)	Transfer (gilt)	1
Not illus.	A3	Transfer (gilt)	1
2	F9659	Filler cap	1
3	F4047	Joint washer	1
4	F5343	Drain plug	1
5	99-0048	Fibre washer	1
6	F9430	Filter	1
7	F1713	Fibre washer	1
8	F9435	Metering screw	1
9	F6874	Metering screw spring	1
10	F9664	Extension pipe, froth tower	1
11	F6673	Spigotted rubber	2
12	F7510	Peg, tank to frame	2
13	14-1301	Nut, tank to frame	2
14	S25-13	Washer, tank to frame	2
15	F6039	Bottom grommet	1
16	S1822	Bottom bolt	1
17	S26-3	Spring washer	1
18	F9588	Bottom bracket	1
19	F3655	Oil feed pipe top half	1
20	F3182	Union nut	1
21	E8904	Oil pipe flex tank, to engine	1
22	E6848	Oil pipe clip	2
23	E8905	Oil pipe engine to oil cooler	1
24	E11742	Rocker to oil cooler flexible pipe	1
25	E11743	Cooler to oil tank flexible pipe	1
26	D702	Clip oil return pipe	4
27	F9530	Feed pipe protection spring	1
28	F9531	Scavenge pipe spring	1
29	F9526	Rear chain oiler pipe	1
Not illus.	F9918	Clip, oil pipes to frame	2
30	F11549	Clip for choke cable	1

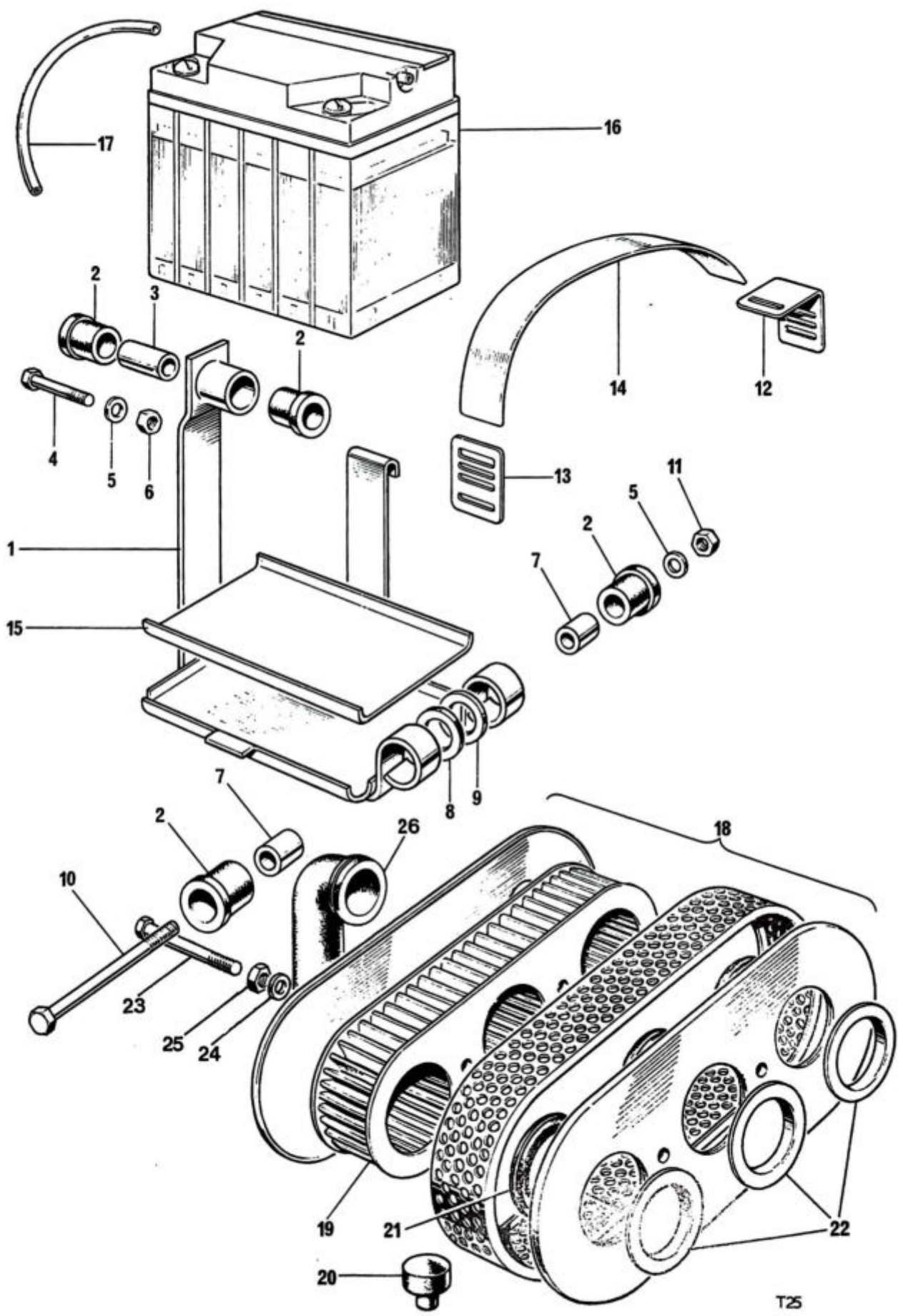

Fig. 27. BATTERY CARRIER AND AIR FILTER

Ref. No.	Part No.	DESCRIPTION	QUANTITY	REMARKS
BATTERY CARRIER AND AIR FILTER				
1	F9343	Battery carrier	1	
2	F9351	Spigotted rubber bush	4	
3	F9349	Top distance tube	1	
4	14-0222	Top bolt	1	
5	S25-3	Washer	2	
6	14-1302	Nut	1	
7	F9350	Bottom distance tube	2	
8	F9352	Rubber washer	2	
9	F4299	Washer	2	
10	14-0228	Bolt	1	
11	14-1302	Nut	1	
12	F9354	Strap buckle top	1	
13	F9355	Strap buckle bottom	1	
14	F9353	Retaining strap	1	
15	F8091	Rubber battery tray	1	
Not illus.	A52	Transfer, positive earth	1	
16	54027029	Battery PUZ5A (99-0719)	1	
17	F7431	Battery vent pipe	1	
18	D2567	AIR CLEANER C/W ELEMENT	1	
19	E9138	Element	1	
20	F7835	Buffer	1	
21	F9562	Grommet	3	
22	E9586	Sleeve	3	
23	14-0213	Bolt	1	
24	S602	Washer	2	
25	14-0401	Locknut	2	
26	F9563	Connector hose	1	

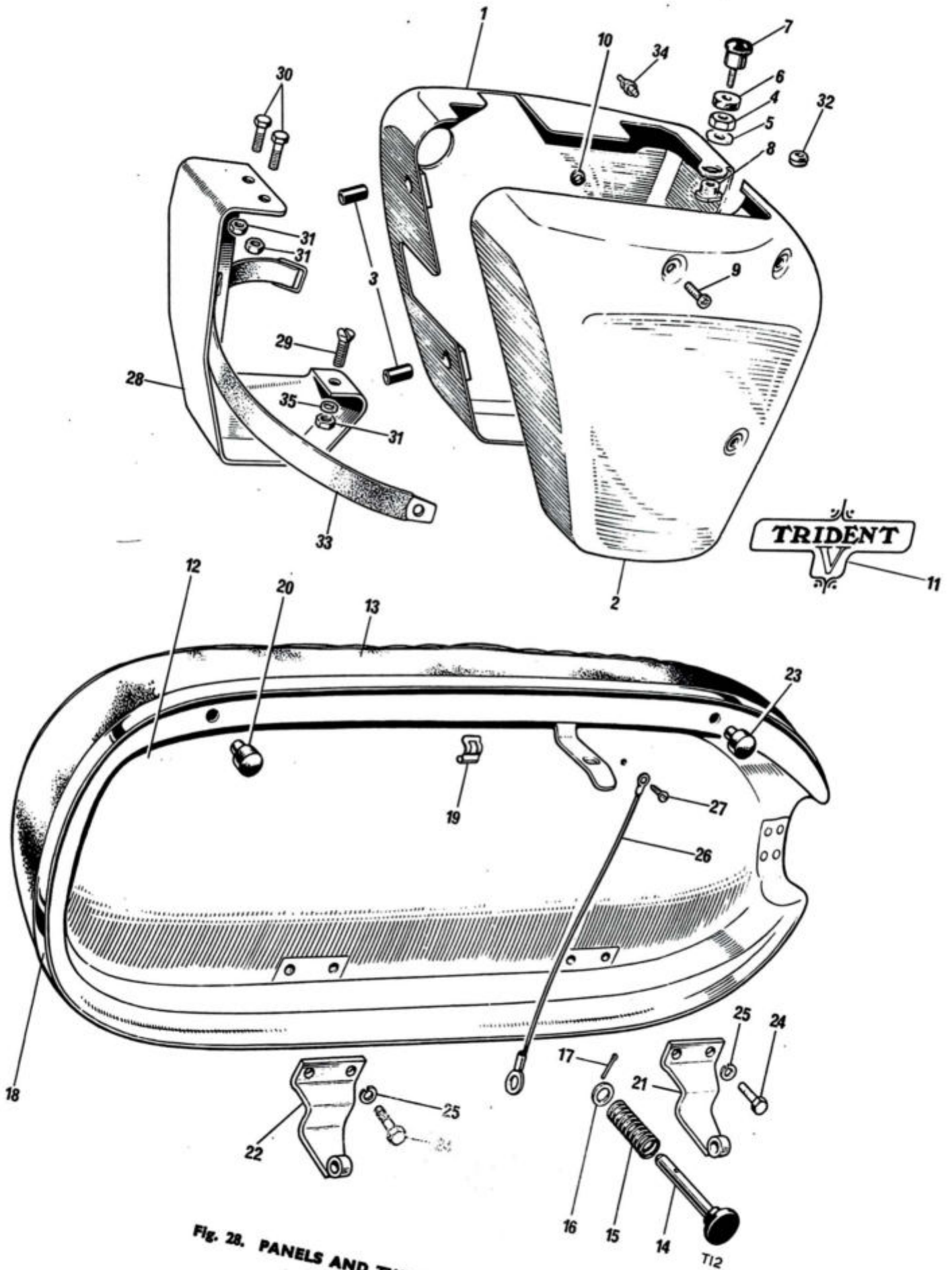

Fig. 28. PANELS AND TWINSEAT

Ref. No.	Part No.	DESCRIPTION	QUANTITY	REMARKS
PANELS AND TWINSEAT				
1	F13236	D.S. Panel	1	
2	F12031	T.S. Panel	1	
3	F6673	Grommet	2	
4	S1833	Lock nut	1	
5	S25-71	Washer	1	
6	F6968	Rubber spacer	1	
7	F9445	Release knob	1	
8	F9590	Boss	1	
9	14-2205	Screw T.S. panel to oil tank	4	
10	F9442	Grommet	3	
11	D3954	Transfer 'Trident V'	2	
12	F12039	TWINSEAT	1	
13	F12239	Twinseat cover	1	
14	F7560	Knob	1	
15	F4228	Spring	1	
16	E1719	Washer	1	
17	—	Split pin ($\frac{3}{32}$ in. x $\frac{1}{2}$ in.)		Reference only
18	D696	Trim strip	1	
19	D697	Sprag	4	
20	F4898	Buffer	2	
21	F8026	Front hinge	1	
22	F7862	Rear hinge	1	
23	F7835	Buffer	2	
24	14-0101	Bolt, hinge	4	
25	S26-2	Spring washer	4	
26	D2087	Check wire	1	
27	D2381	Self tapping screw	1	
28	F9650	Toolbox	1	
29	14-0503	Screw, toolbox to battery carrier	1	
30	14-0102	Bolt	2	
31	14-1301	Nut	3	
32	F9770	Panel buffer	2	
33	F9749	Toolroll strap	1	
34	D2524	Clip, clutch cable	1	
35	F4299	Washer	3	

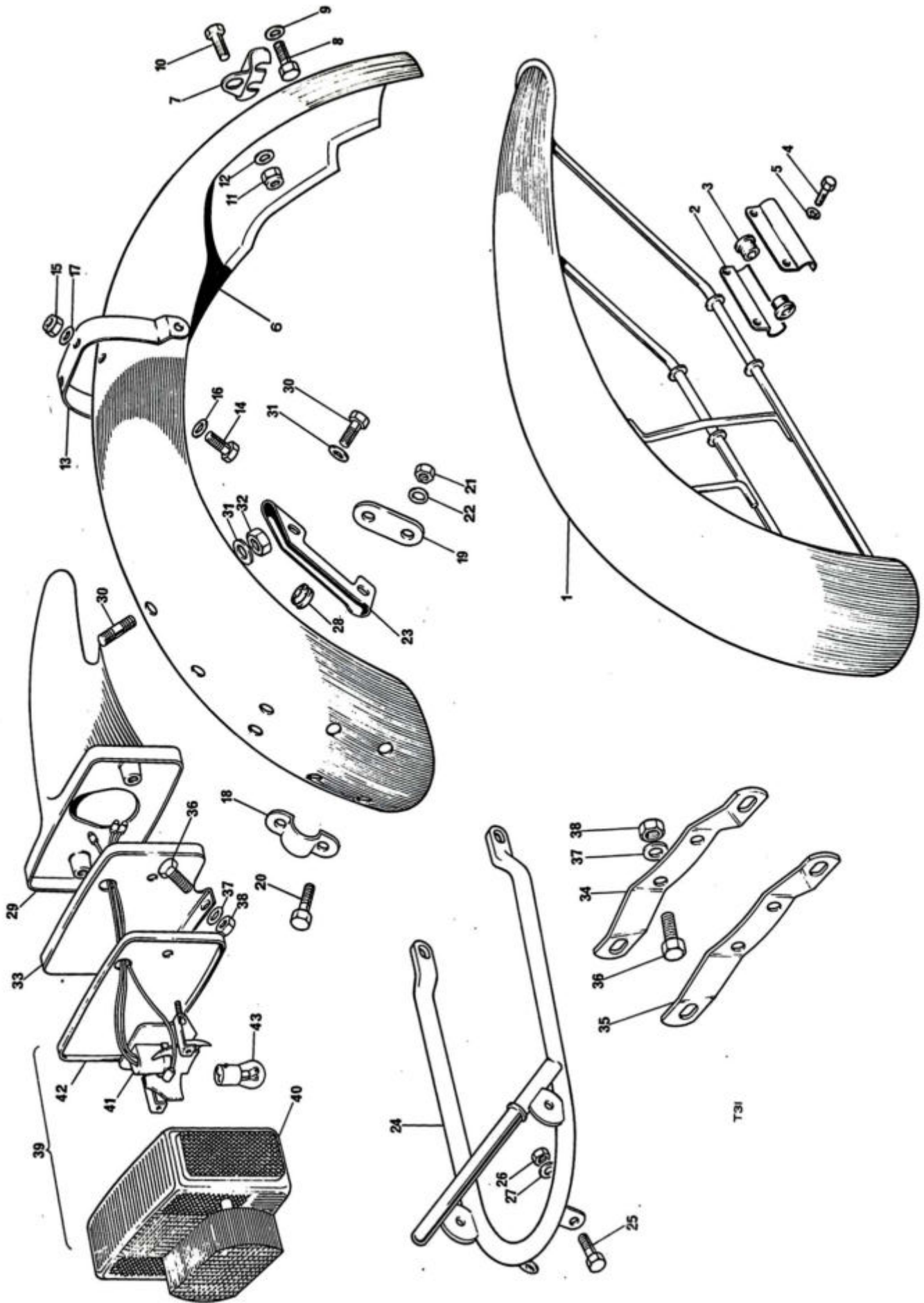

Fig. 29. FENDERS AND TAIL LAMP

Ref. No.	Part No.	DESCRIPTION	QUANTITY	REMARKS
FENDERS AND TAIL LAMP				
1	H4270	Front fender	1	
2	H4022	Bracket	4	
3	H4021	Rubber bush	4	} Stay to fork leg
4	14-0103	Bolt	4	
5	D2427	Washer	4	
6	F14321	Rear fender	1	
7	F6851	Bracket (bottom front)	1	
8	S1822	Bolt	2	} Bracket to pivot lug
9	S26-3	Washer	2	
10	14-0101	Bolt	1	} Bracket to mudguard
11	14-1201	Nut	1	
12	F6310	Washer	1	
13	F6915	Bridge	1	
14	14-0102	Bolt	2	} Bridge to mudguard
15	14-1201	Nut	2	
16	S25-1	Washer	2	
17	F6310	Washer	2	
18	F5994	Clip-guard to frame rail	1	
19	F6031	Backing plate	1	
20	S1822	Bolt	2	} Clip to mudguard
21	14-1302	Nut	2	
22	S25-3	Washer	2	
23	F7826	Wiring protector	1	
24	F12879	Lifting handle	1	
25	14-0102	Bolt	2	} Lifting handle to mudguard
26	14-1301	Nut	2	
27	S25-1	Washer	2	
28	199001	Grommet, tail lamp lead		Reference only
29	F12786	Tail lamp support	1	
30	14-1401	Stud	1	} Tail lamp support to fender
31	D2329	Washer	1	
32	14-1301	Nut	1	
33	F14799	Support plate	1	
Not illus.	14-6604	Screw - support plate	1	
Not illus.	F14800	Nut - tail lamp attachment	2	
34	F14784	Rear no. plate bracket - top	1	
35	F6850	Rear no. plate bracket - bottom	1	
36	14-0102	Bolt	4	} No. plate brackets to fender
37	D2329	Washer	4	
38	14-1301	Nut	4	
39	56513	STOP - TAIL LAMP - L917 (99-1252)	1	
40	54584930	Lens (complete with screws) (99-1257)	1	
41	54584931	Base assembly		Reference only
42	54583924	Gasket		Reference only
43	380	Bulb (99-0542)	1	

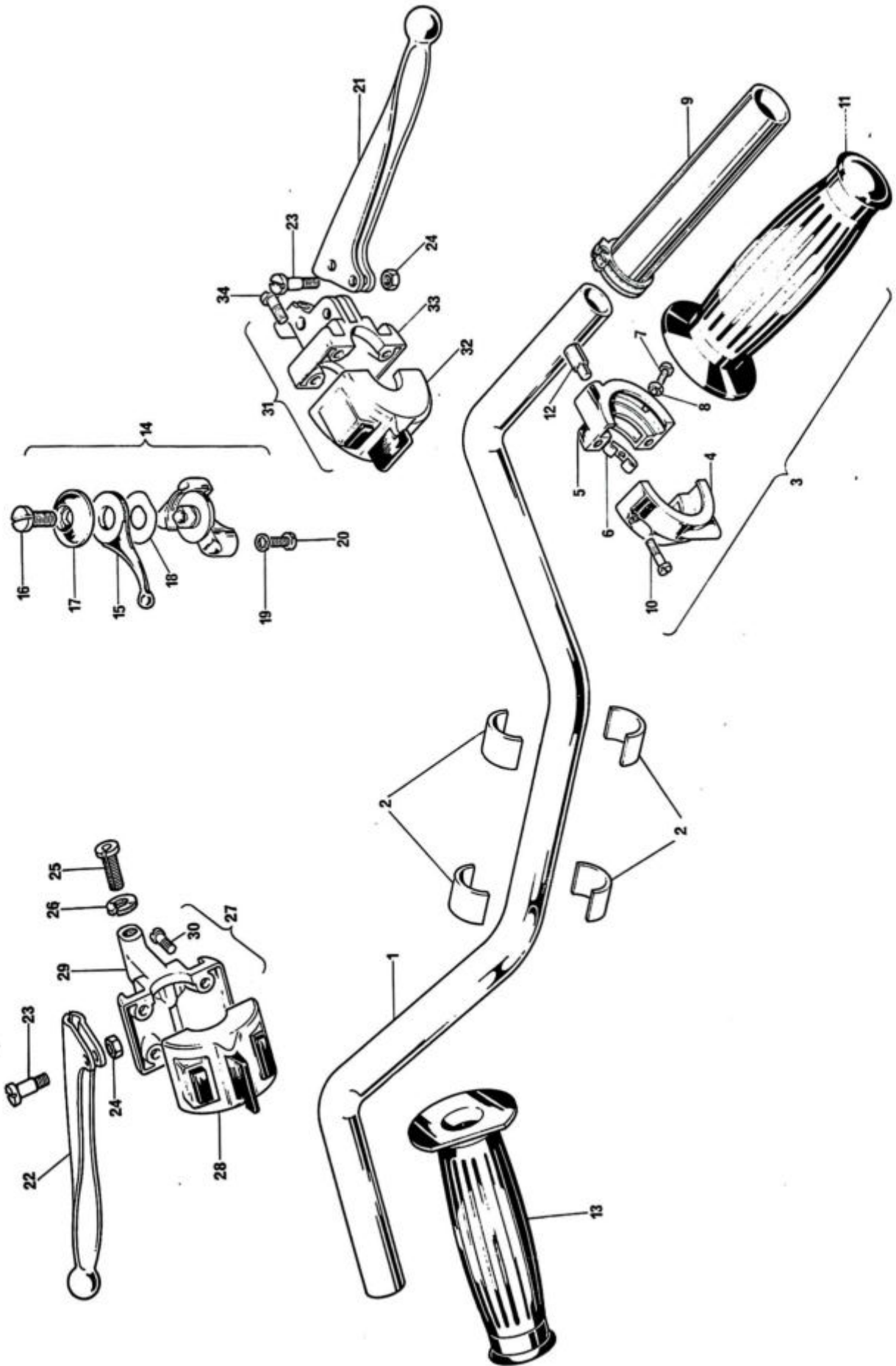

FIG. 30. HANDLEBAR AND CONTROL LEVERS

Ref. No. Part No. DESCRIPTION QUANTITY REMARKS

HANDLEBAR AND CONTROL LEVERS

1	H4495	Handlebar	1	
2	H1425	Packing piece	4	
3	364/11	TWISTGRIP (99-1102)	1	
4	364/013	Body, top half	1	
5	364/014	BODY, BOTTOM HALF (99-0246)	1	
6	16/008	Friction spring		Reference only
7	16/009	Screw		Reference only
8	16/010	Locknut		Reference only
9	364/017	Rotor (99-0244)	1	
10	11/013	Screw (99-0225)	2	
11	H2125	Grip	1	
12	16/011	Cable stop		Reference only
13	H2124	Grip—L.H.	1	
14	D3567	AIR CONTROL LEVER	1	
15	12/556	Lever		Reference only
16	12/607	Bolt		Reference only
17	12/606	Cap		Reference only
18	12/033	Spring washer		Reference only
19	GS299	Shakeproof washer	2	
20	D3896	Screw	2	
21	D3583	Front brake lever (alloy)	1	
22	D3657	Clutch lever (alloy)	1	
23	S2048	Pivot pin	2	
24	14-1301	Nut	2	
25	D3585	Adjuster	2	
26	D3586	Lockring	2	
27	39596	HANDLEBAR SWITCH—L.H.		Reference only
28	54033666	Switch half		Reference only
29	54340882	Lever half (99-1187)	1	
30	54115246	Screw (99-1188)	4	
31	39785	HANDLEBAR SWITCH—R.H.		Reference only
32	54033722	Switch half		Reference only
33	54343793	Lever half (99-1261)	1	
34	54115246	Screw (99-1188)	4	

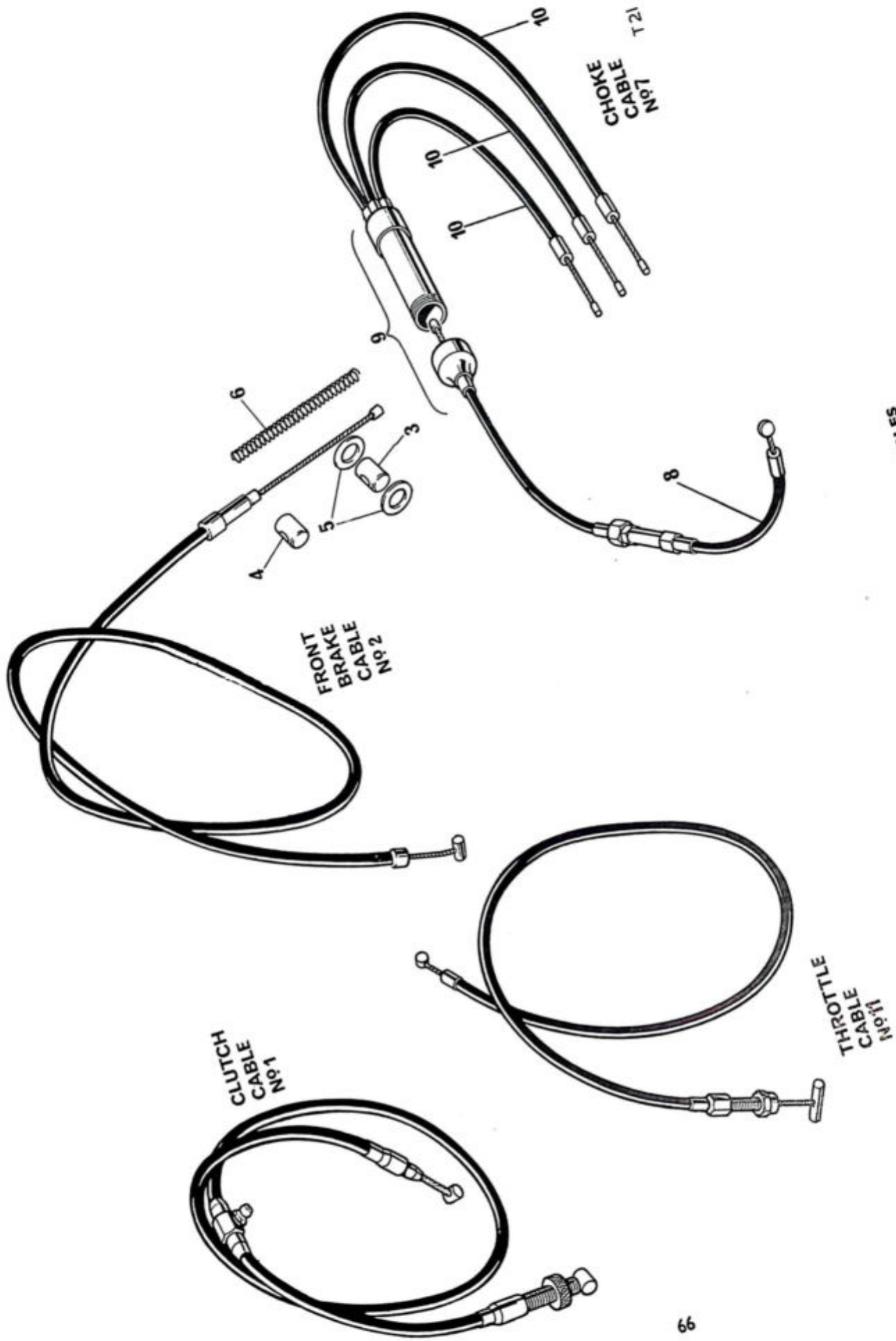
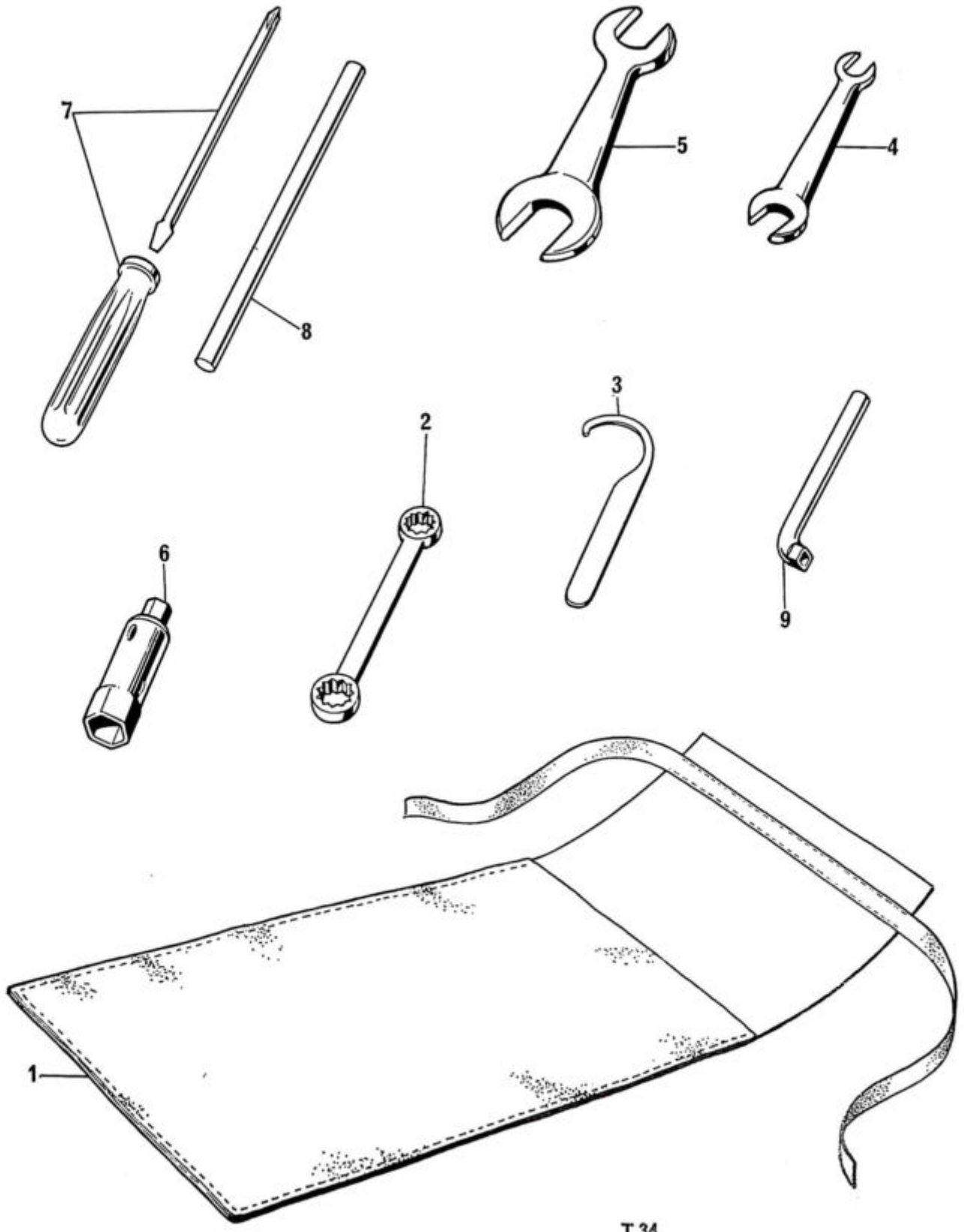

FIG. 31. CONTROL CABLES

Ref. No.	Part No.	DESCRIPTION	QUANTITY	REMARKS
CONTROL CABLES				
1	D2445	Clutch cable	1	
2	D4185	FRONT BRAKE CABLE	1	
3	W3997	Bush	1	
4	W3996	Bush	1	
5	E12500	Washer	2	
6	W4014	Spring	1	
7	D3565	CHOKE CABLE ASSEMBLY	1	
8	D3566	Cable, lever to junction box	1	
9	D1978	Junction box (244/2080)	1	
10	D2061	Cable, junction box to carburetter	3	
11	D890	Throttle cable	1	



T 34

Fig. 32. TOOLKIT

Ref. No. Part No. DESCRIPTION QUANTITY REMARKS

TOOLKIT

—	D3351	TOOLKIT COMPLETE	1
1	D291	Tool roll	1
2	D1907	Ring spanner	1
3	D2184	"C" spanner	1
4	D3350	Open ended spanner	1
5	D2647	Open ended spanner	1
6	D1910	Plug spanner	1
7	D767	Screwdriver complete	1
8	D1911	Tommy bar	1
9	D2020	Tappet spanner	1

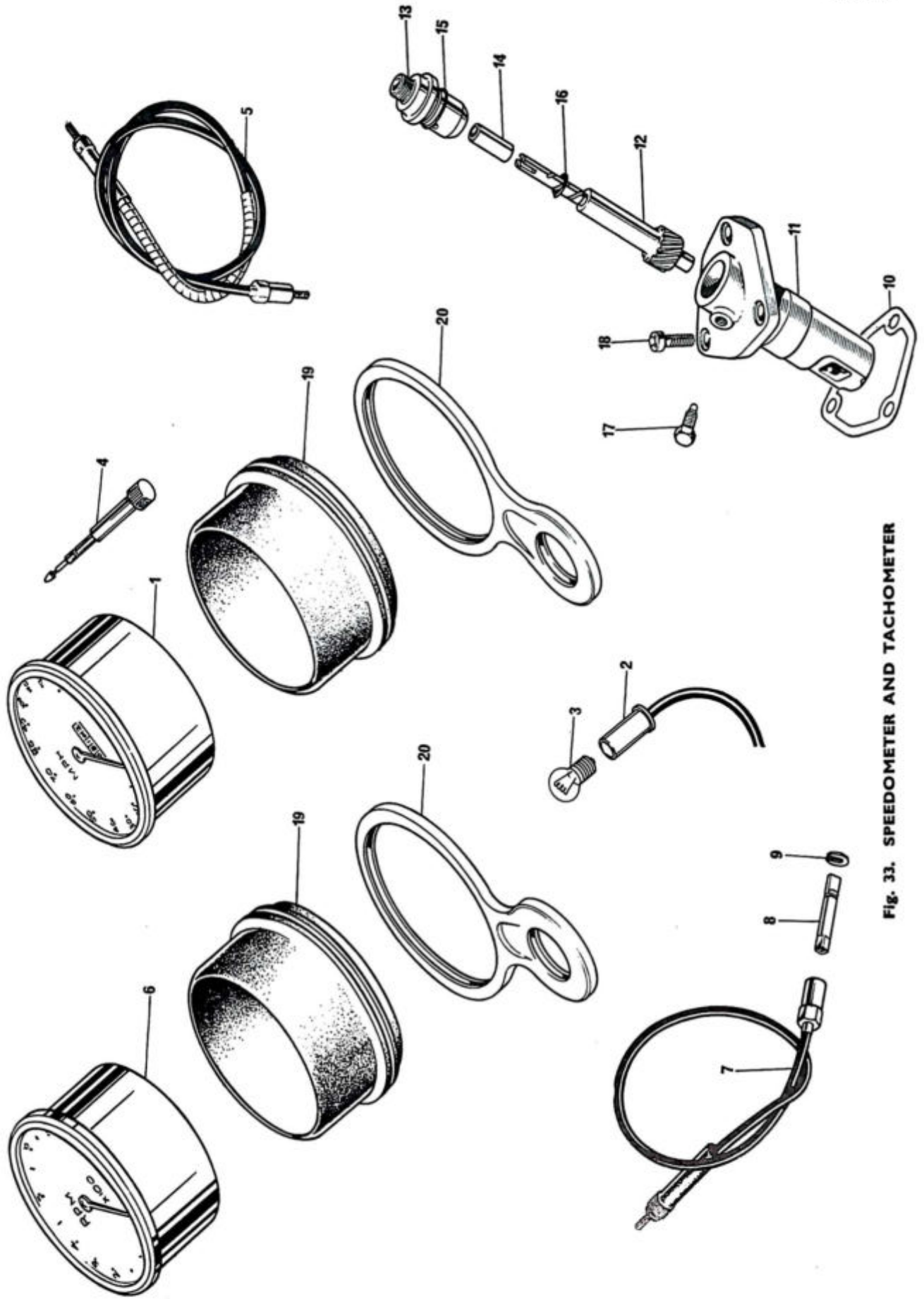

Fig. 33. SPEEDOMETER AND TACHOMETER

Ref. No. Part No. DESCRIPTION QUANTITY REMARKS

SPEEDOMETER AND TACHOMETER

1	D2394	Speedometer head MPH (SSM 5007/00)	1	
1	D2395	Speedometer head KPH (SSM 5007/01)	1	Available
2	54953387	Bulbholder	1	Reference only
3	643	Bulb	1	Reference only
4	41-148-203-10	Trip control (99-0176)	1	
5	D3376	Speedometer cable	1	
6	D2396	Tachometer head (RSM 3003/13)	1	
7	D578	Tachometer cable	1	
8	31-371-398	Spade (99-0173)	1	
9	D494	Circlip	1	
10	E11439	Joint washer, tacho drive	1	
11	E8740	Housing tacho driven gear	1	
12	E8741	Driven gear	1	
13	E8742	Tacho bearing housing	1	
14	E6124	Bush	1	
15	E3309	'O' ring	1	
16	E6299	'O' ring, driven gear	1	
17	E8744	Locating screw	1	
18	14-6605	Screw, housing to c/case	3	
19	D2600	Rubber cup	2	
20	H4026	Bracket	2	

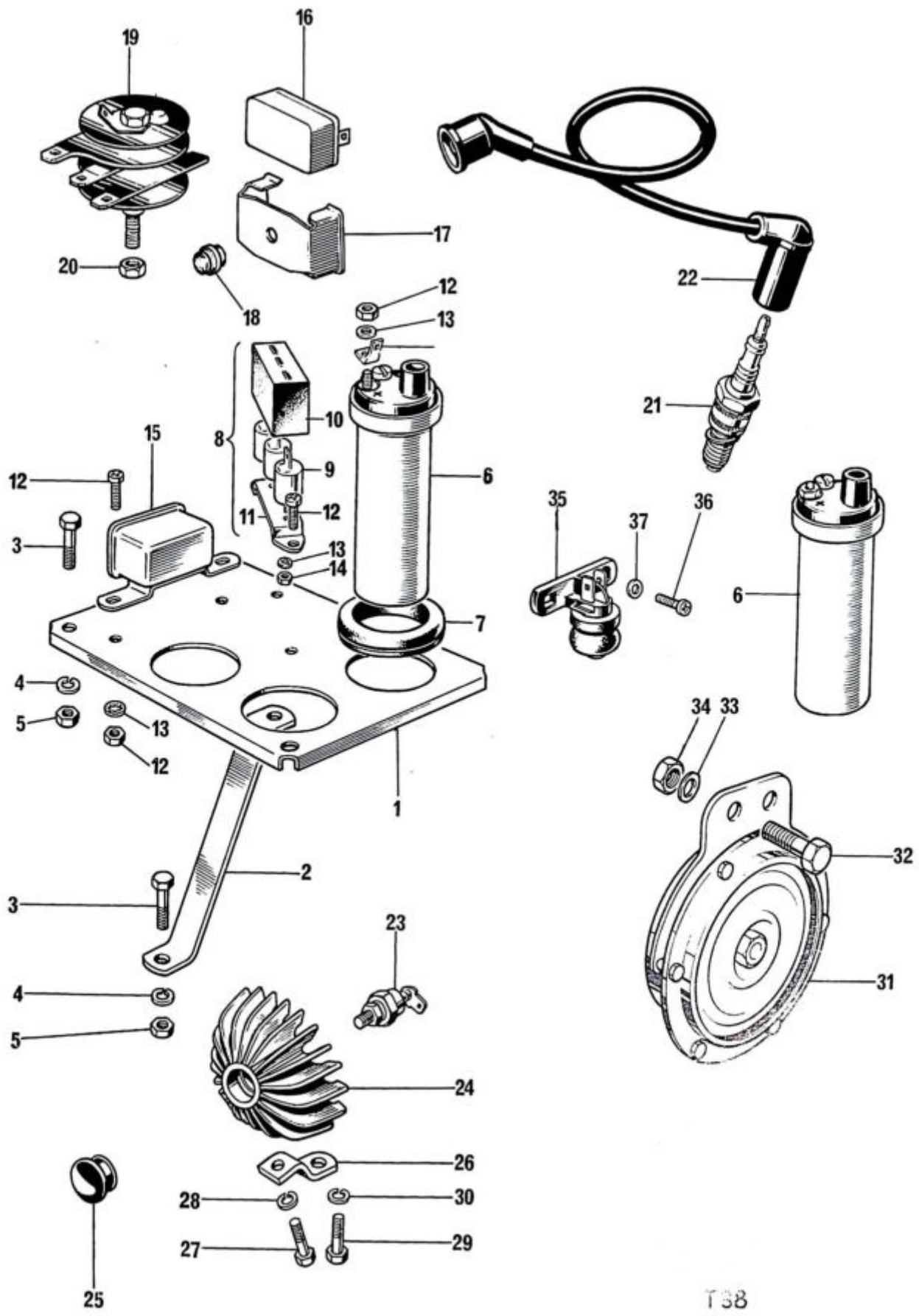

Fig. 34. IGNITION COILS, HORNS, RECTIFIER AND ZENER DIODE

Ref. No.	Part No.	DESCRIPTION	QUANTITY	REMARKS
IGNITION COILS, HORNS, RECTIFIER ZENER DIODE				
1	F13230	Electrical platform	1	
2	F9565	Platform stay	1	
3	14-0102	Bolt	4	
4	D2329	Washer	4	
5	14-1302	Nut	4	
6	D2203	Ignition coil—17m12 (45223)	3	
7	F9561	Coil grommet	3	
8	47637	CAPACITOR PACK—2CP		Reference only
9	54420128	Capacitor (99-1043)	3	
10	54418528	Cover (99-0767)	1	
11	54418526	Base plate (99-1160)	1	
12	S2079	Screw	5	
13	D2391	Shakeproof washer	4	
14	S778	Nut	4	
15	33213	Horn relay 6RA (99-1227)	1	
16	35048	Flasher unit—8FL (99-1201)	1	
17	54385091	Clip, flasher unit	1	
18	F12569	Grommet, flasher unit	1	
19	99-0589	RECTIFIER (49072)	1	
20	F5338	Nut (156596)	1	
21	N3	Sparking plug		Reference only
22	D3043	Plug cover (WC200)	3	
23	49345	Zener diode (99-0590)	1	
24	H2237	Heat sink	1	
25	H2275	Plug, heat sink	1	
26	H4160	Bracket, heat sink	1	
27	14-6102	Bolt	1	
28	S26-2	Washer } Bracket to heat sink	1	
29	14-0113	Bolt	1	
30	S26-3	Washer } Bracket to fork leg	1	
31	D2623	Horn (Clearhooter HF80—low note)	1	
31	D2624	Horn (Clearhooter HF80—high note)	1	
32	14-0103	Bolt	4	
33	S25-1	Washer } Horn mounting	4	
34	14-1201	Nut	4	
35	34815	Stoplamp switch 118SA (99-1028)	1	
36	S683	Screw	2	
37	E2351	Washer	2	

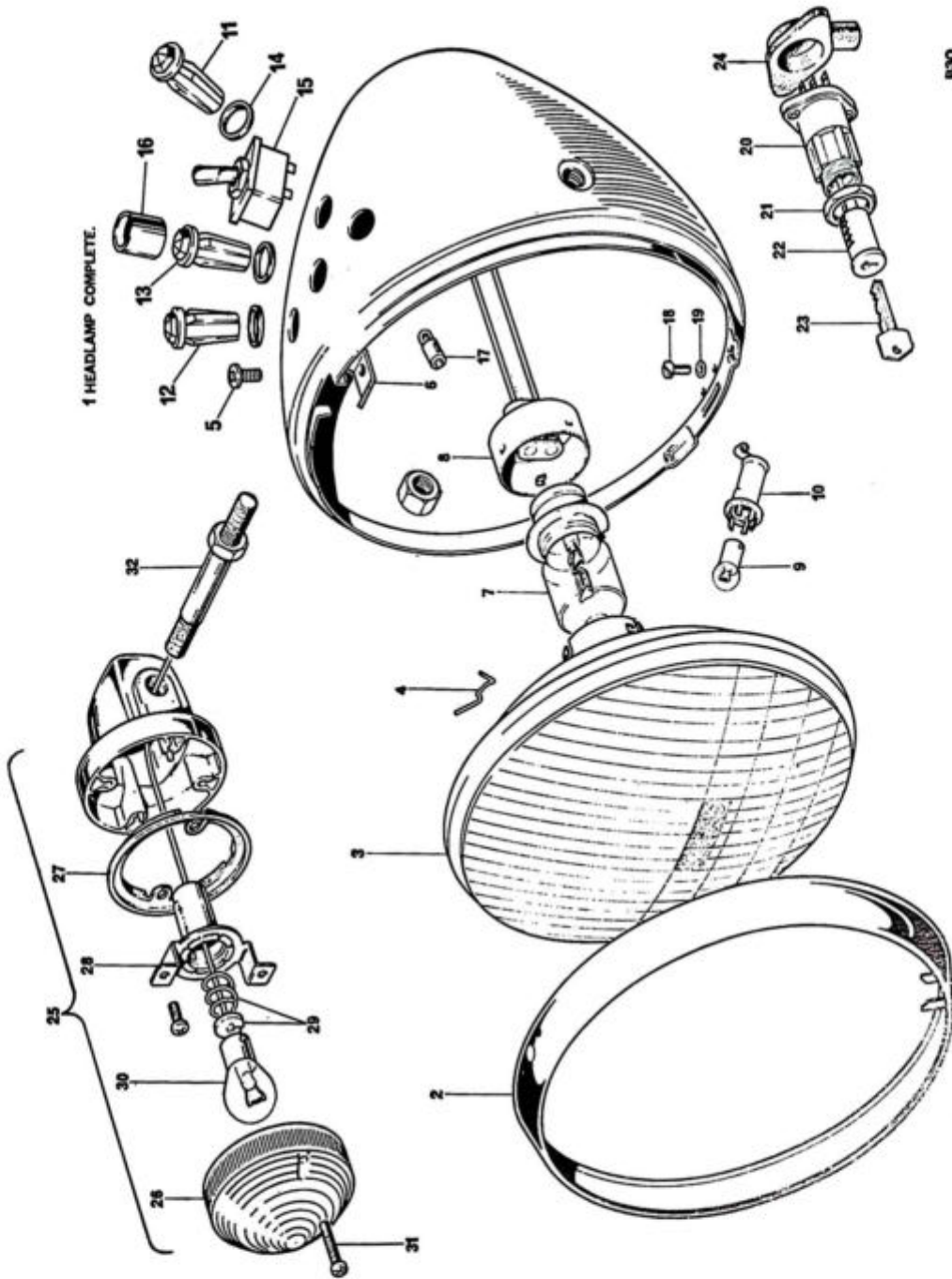

FIG. 34. HEADLAMP AND FLASHER LAMPS

Ref. No. Part No. DESCRIPTION QUANTITY REMARKS

HEADLAMP AND FLASHER LAMPS

1	60512	HEADLAMP COMPLETE SS 700 P.(99-1267)	1	
2	553248	Rim (99-0692)	1	
3	54525272	Light unit (99-1212)	1	
4	504665	Fixing wire (99-0683)	6	
5	144921	Screw	Reference only
6	534296	Plate	Reference only
7	370	Main bulb (45/35V) (99-1214)	1	
8	554602	Bulbholder	Reference only
9	989	Pilot bulb (99-0548)	1	
10	54573590	Pilot bulbholder (99-1213)	1	
11	54363454	Warning light (Red) (99-1208)	1	
12	54363455	Warning light (Green) (99-1209)	1	
13	54363453	Warning light (Amber) (99-1207)	1	
14	54140331	Sealing washer (99-1210)	3	
15	35710	Light switch (99-0563)	1	
16	54525212	Shield, warning light	Reference only
17	281	Bulb, warning light (99-0537)	3	
18	54115106	Screw, (99-1223)	2	
19	143086	Washer, (99-1224)	2	
Not illus.	54961595	Wiring harness (99-1260)	1	
20	31899	IGNITION SWITCH (99-0558)	1	
21	54130041	Nut	Reference only
22	F6981	IGNITION LOCK C/W KEY	1	
23	D622	Key (state serial number)	As required
24	H2262	Cover, ignition switch	1	
25	56147	FLASHER LAMP (99-1190)	4	
26	54581638	Lens (99-1191)	1	
27	54580300	Gasket	Reference only
28	554548	Bulbholder	Reference only
29	573832	Interior assembly	Reference only
30	382	Bulb (99-1192)	1	
31	54123401	Screw (99-1193)	2	
32	60600092	Stanchion, flasher lamp (99-1246)	4	

STANDARD HARDWARE SPECIFICATION BOLTS

Part No.	Material	Thd. dia.	Length under head	Min. length of thread	Hexagon A.F.
S1822	Steel	$\frac{5}{16}$ " UNF	$\frac{1}{2}$ "	$\frac{27}{64}$ "	0.500"
S1910	"	$\frac{3}{8}$ " UNF	$\frac{13}{16}$ "	$\frac{13}{16}$ "	0.565"
S1919	"	$\frac{5}{16}$ " UNC	$1\frac{5}{8}$ "	$\frac{7}{8}$ "	0.500"
S2010	"	$\frac{1}{4}$ " UNF	$\frac{13}{16}$ "	$\frac{3}{4}$ "	0.375"
14-0101	"	$\frac{1}{4}$ " UNF	$\frac{1}{2}$ "		0.438"
14-0102	"	$\frac{1}{4}$ " UNF	$\frac{5}{8}$ "		0.438"
14-0103	"	$\frac{1}{4}$ " UNF	$\frac{3}{4}$ "		0.438"
14-0105	"	$\frac{1}{4}$ " UNF	1"		0.438"
14-0113	"	$\frac{5}{16}$ " UNF	$\frac{5}{8}$ "		0.500"
14-0114	"	$\frac{5}{16}$ " UNF	$\frac{3}{4}$ "		0.500"
14-0115	"	$\frac{5}{16}$ " UNF	$\frac{7}{8}$ "		0.500"
14-0116	"	$\frac{5}{16}$ " UNF	1"		0.500"
14-0126	"	$\frac{3}{8}$ " UNF	$\frac{3}{4}$ "		0.563"
14-0128	"	$\frac{3}{8}$ " UNFF	1"		0.563"
14-0132	"	$\frac{7}{16}$ " UN	$\frac{7}{8}$ "		0.625"
14-0201	"	$\frac{1}{4}$ " UNF	1"	$\frac{3}{4}$ "	0.438"
14-0202	"	$\frac{1}{4}$ " UNF	$1\frac{1}{8}$ "	$\frac{3}{4}$ "	0.438"
14-0205	"	$\frac{1}{4}$ " UNF	$1\frac{1}{2}$ "	$\frac{3}{4}$ "	0.438"
14-0208	"	$\frac{1}{4}$ " UNF	$2\frac{1}{4}$ "	$\frac{3}{4}$ "	0.438"
14-0216	"	$\frac{5}{16}$ " UNF	$1\frac{1}{8}$ "	$\frac{7}{8}$ "	0.500"
14-0217	"	$\frac{5}{16}$ " UNF	$1\frac{1}{4}$ "	$\frac{7}{8}$ "	0.500"
14-0219	"	$\frac{5}{16}$ " UNF	$1\frac{1}{2}$ "	$\frac{7}{8}$ "	0.500"
14-0220	"	$\frac{5}{16}$ " UNF	$1\frac{3}{4}$ "	$\frac{7}{8}$ "	0.500"
14-0221	"	$\frac{5}{16}$ " UNF	2"	$\frac{7}{8}$ "	0.500"
14-0222	"	$\frac{5}{16}$ " UNF	$2\frac{1}{4}$ "	$\frac{7}{8}$ "	0.500"
14-0225	"	$\frac{5}{16}$ " UNF	3"	$\frac{7}{8}$ "	0.500"
14-0228	"	$\frac{5}{16}$ " UNF	4"	$\frac{7}{8}$ "	0.500"
14-0234	"	$\frac{3}{8}$ " UNF	$1\frac{3}{4}$ "	1"	0.563"
14-0235	"	$\frac{3}{8}$ " UNF	2"	1"	0.563"
14-0236	"	$\frac{3}{8}$ " UNF	$2\frac{1}{4}$ "	1"	0.563"
14-0237	"	$\frac{3}{8}$ " UNF	$2\frac{1}{2}$ "	1"	0.563"
14-0239	"	$\frac{3}{8}$ " UNF	3"	1"	0.563"
14-0241	"	$\frac{3}{8}$ " UNF	$3\frac{1}{2}$ "	1"	0.563"
14-0242	"	$\frac{3}{8}$ " UNF	4"	1"	0.563"
14-0251	"	$\frac{7}{16}$ " UNF	$2\frac{3}{4}$ "	$1\frac{1}{4}$ "	0.625"
14-6101	"	$\frac{1}{4}$ " UNC	$\frac{1}{2}$ "		0.438"
14-6102	"	$\frac{1}{4}$ " UNC	$\frac{5}{8}$ "		0.438"
14-6115	"	$\frac{5}{16}$ " UNC	$\frac{7}{8}$ "		0.500"
14-6121	"	$\frac{5}{16}$ " UNC	$2\frac{1}{2}$ "		0.500"

NUTS

Part No.	Material	Thd. dia.	Hexagon A.F.	Thickness	Remarks
S778	Steel	No. 10 UNF	0.375"	0.225"	Cleveloc
S1852	"	$\frac{5}{16}$ " UNF	0.437"	0.330"	Philidas
S1906	"	$\frac{1}{4}$ " UNF	0.438"	0.188"	Plain
S1908	"	$\frac{5}{16}$ " UNF	0.438"	0.313"	Plain
S1914	"	$\frac{3}{8}$ " UNEF	1.125"	0.250"	Plain
S2012	"	$\frac{7}{8}$ " UNEF	1.313"	0.438"	Plain
S2013	"	$\frac{3}{4}$ " UNEF	1.313"	0.313"	Plain
S2014	"	$\frac{3}{4}$ " UNEF	1.313"	0.438"	Plain
14-0301	"	$\frac{1}{4}$ " UNF	0.438"	0.224"	Plain
14-0302	"	$\frac{5}{16}$ " UNF	0.500"	0.271"	Plain
14-0303	"	$\frac{3}{8}$ " UNF	0.563"	0.300"	Plain
14-0304	"	$\frac{7}{16}$ " UNF	0.688"	0.375"	Plain
14-0401	"	$\frac{1}{4}$ " UNF	0.438"	0.161"	Lock
14-0402	"	$\frac{5}{16}$ " UNF	0.500"	0.192"	Lock
14-0403	"	$\frac{3}{8}$ " UNF	0.563"	0.224"	Lock
14-0404	"	$\frac{7}{16}$ " UNF	0.688"	0.250"	Lock
14-0701	"	$\frac{1}{4}$ " UNF	0.438"	0.203"	Philidas
14-0702	"	$\frac{5}{16}$ " UNF	0.500"	0.246"	Philidas
14-0703	"	$\frac{3}{8}$ " UNF	0.563"	0.296"	Philidas
14-1201	"	$\frac{1}{4}$ " UNF	0.438"	0.285"	Stiffnut
14-1202	"	$\frac{5}{16}$ " UNF	0.500"	0.335"	Stiffnut
14-1301	"	$\frac{1}{4}$ " UNF	0.438"	0.245"	Stiffnut
14-1302	"	$\frac{5}{16}$ " UNF	0.500"	0.290"	Stiffnut
14-1303	"	$\frac{3}{8}$ " UNF	0.563"	0.320"	Stiffnut
14-1304	"	$\frac{7}{16}$ " UNF	0.688"	0.375"	Stiffnut
14-1305	"	$\frac{1}{2}$ " UNF	0.750"	0.435"	Stiffnut
14-1901	"	$\frac{1}{4}$ " UNF	0.438"	0.283"	Nyloc
14-1902	"	$\frac{5}{16}$ " UNF	0.500"	0.361"	Nyloc
14-1903	"	$\frac{3}{8}$ " UNF	0.563"	0.375"	Nyloc

SCREWS

Part No.	Type of head	Material	Thd. dia.	Length under head	Type of drive
S1916	Cheese head	Steel	$\frac{1}{4}$ " UNC	$1\frac{1}{8}$ "	Cross recess
S1917	Cheese head	"	$\frac{1}{4}$ " UNC	$2\frac{5}{8}$ "	Cross recess
S1918	Cheese head	"	$\frac{1}{4}$ " UNC	$2\frac{3}{8}$ "	Cross recess
S1920	Hex. head	"	$\frac{1}{4}$ " UNC	$\frac{3}{16}$ "	Cross recess
S1929	Countersunk 82°	"	$\frac{1}{4}$ " UNC	$\frac{17}{32}$ "	Slot
S2079	Cheese head	"	No. 10 UNF	$\frac{1}{2}$ "	Pozidrive
14-0604	Cheese head	"	$\frac{1}{4}$ " UNF	$\frac{1}{2}$ "	Cross recess
14-6504	Countersunk (82°)	"	$\frac{1}{4}$ " UNC	$\frac{3}{4}$ "	Cross recess
14-6505	Countersunk (82°)	"	$\frac{1}{4}$ " UNC	$\frac{7}{8}$ "	Cross recess
14-6606	Cheese head	"	$\frac{1}{4}$ " UNC	$\frac{3}{4}$ "	Cross recess
14-6607	Cheese head	"	$\frac{1}{4}$ " UNC	$\frac{7}{8}$ "	Cross recess
14-6608	Cheese head	"	$\frac{1}{4}$ " UNC	1"	Cross recess
14-6609	Cheese head	"	$\frac{1}{4}$ " UNC	$1\frac{1}{4}$ "	Cross recess
14-6610	Cheese head	"	$\frac{1}{4}$ " UNC	$1\frac{1}{2}$ "	Cross recess
14-6611	Cheese head	"	$\frac{1}{4}$ " UNC	$1\frac{3}{4}$ "	Cross recess
14-6612	Cheese head	"	$\frac{1}{4}$ " UNC	2"	Cross recess
14-6613	Cheese head	"	$\frac{1}{4}$ " UNC	$2\frac{1}{4}$ "	Cross recess
14-6614	Cheese head	"	$\frac{1}{4}$ " UNC	$2\frac{1}{2}$ "	Cross recess
14-6615	Cheese head	"	$\frac{1}{4}$ " UNC	3"	Cross recess
14-7004	Socket head	"	$\frac{1}{4}$ " UNC	$\frac{1}{4}$ "	Hex. socket
14-7019	Socket head	"	$\frac{5}{16}$ " UNF	$\frac{7}{8}$ "	Hex. socket
14-7024	Socket head	"	$\frac{5}{16}$ " UNF	2"	Hex. socket

WASHERS—PLAIN

<i>Part No.</i>	<i>Material</i>	<i>l/dia.</i>	<i>o/dia.</i>	<i>Thickness</i>
S25-1	Steel	0.273"	0.563"	0.048"
S25-2	Steel	0.398"	0.750"	0.063"
S25-3	Steel	0.336"	0.625"	0.063"
S25-6	Steel	0.531"	1.031"	0.092"
S25-13	Steel	0.266"	0.469"	0.064"
S25-71	Steel	0.453"	0.750"	0.064"

WASHERS—SPRING

<i>Part No.</i>	<i>Material</i>	<i>l/dia.</i>	<i>o/dia.</i>	<i>o/a height</i>	<i>Thickness</i>
S26-1	Spring Steel	$\frac{3}{8}$ " clearance	$\frac{13}{32}$ "	$\frac{7}{32}$ "	0.104"
S26-2	Spring Steel	$\frac{1}{4}$ " clearance	$\frac{13}{32}$ "	$\frac{3}{16}$ "	0.064"
S26-16	Spring Steel	$\frac{17}{32}$ "	$\frac{7}{8}$ "	$\frac{7}{32}$ "	0.040**
S648	Spring Steel	$\frac{5}{16}$ " clearance	$\frac{1}{2}$ "	$\frac{5}{32}$ "	0.080"

** Double coil.