

TRIUMPH
TIGER CUB

**REPLACEMENT
PARTS CATALOGUE**

No. 9

*

TIGER CUB

'A' RANGE MODELS

T20 T20SS T20SH

FROM ENGINE NO. 94600

TRIUMPH

REPLACEMENT PARTS CATALOGUE No. 9

TIGER CUB
"A" RANGE MODELS
T20
T20SS
T20SH

from Engine No. 94600

September 1963

TRIUMPH ENGINEERING COMPANY LIMITED
MERIDEN WORKS · ALLESLEY · COVENTRY · ENGLAND
TELEPHONE MERIDEN 331 TELEGRAMS "TRUSTY, COVENTRY"

HOW TO USE THIS PARTS CATALOGUE

First check that the engine number of your machine is subsequent to that quoted on the title page.

Next consult the indices on Pages 5 and 6 for the parts or group of parts which you wish to locate. When you have located the parts on the illustration check the reference number on the facing page and make sure from the end columns that the part you have located does apply to your machine.

List the quantities required as single units; do not ask for "2 pairs" or "3 dozen".

In case of painted items always state the colour required. Painted parts are available only in the colours or alternatives specified for that model of that particular year.

<i>Colour</i>	<i>Suffix letter to Part No.</i>
Black	W.
Silver	V.
Kingfisher Blue	K.
Hi-fi Scarlet	HF.

N.B. Hi-fi Scarlet and Kingfisher Blue are flamboyant finishes applied over gold or silver sheen respectively.

Paint is available also in all colours in $\frac{1}{4}$ pint or 1 gallon tins.

TRIUMPH GUARANTEE

1. In this Guarantee the word "machine" refers to the motor cycle, scooter, motor cycle combination or sidecar as the case may be, purchased by the Purchaser.
2. In order to obtain the benefit of this Guarantee, the Purchaser must have correctly completed the registration form and returned it to us within fourteen days of the purchase.
3. We will supply, free of charge, a new part in exchange for, or, if we consider repair sufficient, will repair free of charge any part proved within six months of the date of purchase of any new machine, (three months overseas) or within three months of its renewal or repair in the case of a part already renewed or repaired, to be defective by reason of our faulty workmanship or materials. We do not undertake to bear the cost of fitting such new or repaired part or accessory.
4. Any part considered to be defective must be sent to our Works, carriage paid, accompanied by the following information:—
 - (a) Name of purchaser and his address;
 - (b) Date of purchase of machine;
 - (c) Name of dealer from whom the purchase was made;
 - (d) Engine number and model.
5. This Guarantee shall not extend to defects or damage appearing after misuse, neglect, abnormal stress or strain, or the incorporation or affixing of unsuitable attachments or parts and in particular:—
 - (a) Hiring out;
 - (b) Racing and Competitions;
 - (c) Adaptation or alteration of any part or parts after leaving our Works;
 - (d) The attaching of a sidecar in a manner not approved by us or to an unsuitable motor cycle.

This Guarantee shall not extend to machines whose trade mark, name or manufacturing number has been altered or removed, or in which has been used any part not supplied or approved by us, or to tyres, saddles, chains, speedometers, revolution counters and electrical equipment or to parts supplied to the order of the Purchaser and different from our standard specification.
6. Our liability and that of our dealer who sells the machine, shall be limited to that set out in this guarantee, and no other claims including claims for consequential damage or injury to person or property, shall be admissible. All other conditions and warranties statutory or otherwise and whether express or implied are hereby excluded and no guarantee other than that expressly herein contained applies to the machine to which this Guarantee relates or any accessory or part thereof.
7. We reserve the right to modify or deviate from the Published Specification without notice.

REPAIRS GUARANTEE

1. Whilst the highest standard of workmanship and materials is aimed at, we cannot accept liability for any defects appearing more than three months after the machine, assembly or component has left our Works after being repaired.
2. We will repair or replace at our option free of charge any defective work, materials or parts relating to the repairs carried out by us appearing within that time but shall not be under any further or other liability for any other loss or damage whether direct or consequential and our liability shall be limited to the cost of so making good. We do not undertake to bear the cost of fitting any replacement or repaired part.
3. We do not accept liability in respect of parts of proprietary manufacture, e.g. tyres, saddles, chains, speedometers, revolution counters and electrical equipment which may be used by us in effecting a repair. All other conditions and warranties statutory or otherwise express or implied are hereby excluded.

TRIUMPH SPARES

HOW TO ORDER. Every part is indicated by number, and this should be quoted together with the description. In order to assist customers, dimensions have been given in many cases where parts are similar. Parts where possible have been listed in order of assembly and a number of the illustrations show the assembly order also. With these aids there should be no difficulty in identifying the parts you require. **Always head your order with the engine number, stamped on the front engine lug, together with the prefix letters.**

WHERE TO OBTAIN. Triumph Spare Parts can only be obtained from an authorised Triumph Dealer, and we recommend our customers to place their orders with the Triumph Dealer in their district. When parts not usually asked for are required, and for which the Dealer may have to write or obtain specially, the postage or carriage incurred becomes payable.

Triumph Spares are not supplied to private owners direct from the factory. A list of authorised dealers who stock Triumph spares is published overleaf. If difficulty is experienced in obtaining the required parts, the matter should be taken up directly with the Triumph Spares Department.

Customers are warned against the risk incurred by purchasing parts that are not of genuine Triumph manufacture. This risk is eliminated if parts are ordered as instructed from recognised Dealers.

PATTERNS AND PARTS FOR REPAIR. It is not necessary to send patterns if the part number is quoted. The sending of patterns often delays the order as parcel post or rail takes longer than letter post.

Parts sent to Coventry for repair, replacement, or as patterns should bear the sender's name and address and clear instructions should accompany the parts. In your own interest send a copy of the advice note under separate cover. All parts must be forwarded carriage paid and care should be taken to ensure that all remittances are sent separately and not enclosed with the parts. Fragile units such as cylinders, etc., should always be boxed to avoid damage in transit. Complete machines should have all fitments such as windscreens, driving mirrors, tools, etc., removed by the sender before despatch, as it is impossible for us to accept responsibility in the event of loss in transit. We are always pleased to give estimates for overhauling and repairs, but should an estimate not be accepted, a charge will be made covering cost of dismantling and re-assembling, if carried out.

Communications relating to Parts should be addressed to the SPARES DEPARTMENT and for repairs, guarantee claims and technical advice to the SERVICE DEPARTMENT, Triumph Engineering Co. Ltd., Meriden Works, Allesley, Coventry. In order to facilitate quick reference, the quoting of any number, invoice number or reference from previous communications is essential. Accessories not of our manufacture should be sent direct to the actual makers, whose names and addresses appear below.

PROPRIETARY GROUP

Ancillary equipment which is fitted to our motor cycles is of the highest quality and is guaranteed by the manufacturers and not by ourselves. Any repairs or claims should be directed to the actual makers or their local agents who will always give owners every possible assistance. The following are the addresses of the various manufacturers:—

CARBURETTERS.

Messrs. Amal Ltd.,
Holdford Road, Witton, Birmingham, 6.

CHAINS.

Renold Chains Ltd.,
Wythenshawe, Manchester.

ELECTRICAL EQUIPMENT.

Messrs. J. Lucas Ltd.,
Gt. Hampton Street, Birmingham, 18.

TYRES.

Dunlop Rubber Co. Ltd.,
Fort Dunlop,
Birmingham, 24.
The Avon India Rubber Co. Ltd.,
Melksham,
Wiltshire.

SPARKING PLUGS.

Champion Sparking Plug Co. Ltd.,
Feltham, Middlesex.

SPEEDOMETERS.

Messrs. Smiths Motor Accessories Ltd.,
Cricklewood Works, London, N.W.2.

SUSPENSION UNITS.

Messrs. Girling Ltd.,
Kings Road, Tyseley, Birmingham, 11.

ILLUSTRATION INDEX

<i>Fig. No.</i>		<i>Page No.</i>
1	CRANKSHAFT, PISTON AND TIMING GEARS	14
2	CRANKCASE	16
3	CYLINDER BARREL AND HEAD	18
4	OIL PUMP AND CONTROL PEDALS	20
5	GEARBOX SHAFTS AND GEARS	22 & 24
6	CLUTCH AND CHAINS	26
7	FRAME COMPLETE	28
8	FOOTRESTS, CHAINGUARDS, PROPSTAND ETC.	30
9	TELESCOPIC FRONT FORK T20	32
10	TELESCOPIC FRONT FORK T20SS AND T20SH	34
11	FRONT WHEEL T20	36
12	FRONT WHEEL T20SS AND T20SH	38
13	REAR WHEEL40 & 42
14	MUDGUARDS AND NUMBER PLATES	44
15	TWINSEAT, REAR PANELS AND EXHAUST SYSTEM	46
16	PETROL AND OIL TANKS	48
17	BATTERY CASE, TOOLBOX AND AIR FILTER	50
18	HANDLEBARS AND CONTROL LEVERS T20	52
19	HANDLEBARS AND CONTROL LEVERS T20SS AND T20SH	54
20	CONTROL CABLES	56
21	AMAL CARBURETTER, TYPE 376	58
22	AMAL CARBURETTER, TYPE 32	60
23	ELECTRICAL EQUIPMENT, T20, T20SS AND T20SH	62
24	CONTACT BREAKER AND IGNITION COILS	64
25	STATOR, TAIL LAMP AND STOP LAMP SWITCH	66
26	SPEEDOMETER AND TACHOMETER EQUIPMENT	68

INDEX

	<i>Page</i>		<i>Page</i>
AIR FILTER	51, 61	MUDGUARDS AND NUMBER PLATES	45
ALTERNATIVE SPROCKETS	11	OIL PUMP	21
BATTERY CARRIER	51	OIL TANK	49
CARBURETTER	59, 61	PETROL TANK	49
CARTON PACKS	10, 11	PILLION FOOTRESTS	31
CENTRE STAND	29	PISTONS	15
CHAINGUARDS	31	PROP STAND	31
CHAINS	27	REAR PANELS	47
CLUTCH	27	REAR WHEEL	41, 43
COIL	65	RECTIFIER	63
CONTACT BREAKER	65	ROTOR	15
CONTROL CABLES	57	SILENCERS	47
CONTROL LEVERS	53, 55	SPARKING PLUGS	65
CRANKCASE	17	SPEEDOMETER	69
CRANKSHAFT	15	STATOR	67
CYLINDER BARREL AND HEAD	19	STEERING RACES	29
ELECTRICAL EQUIPMENT	63, 65, 67	SUSPENSION UNITS	29
ENGINE BOLTS	29	SWITCHES	63
ENGINE SPROCKET	15	TACHOMETER	69
EXHAUST PIPES	45	TIMING GEARS	15
FOOTRESTS	31	TOOLBOX AND TOOLKIT	51
FRAME	29	TWINSEAT	47
FRONT FORKS	33, 35	TWISTGRIP	53, 55
FRONT WHEEL	37, 39	VALVES	19
GASKET SETS	11	WIRING HARNESS	63
GEARBOX	23, 25		
HANDLEBARS	53, 55		
HORN	63		

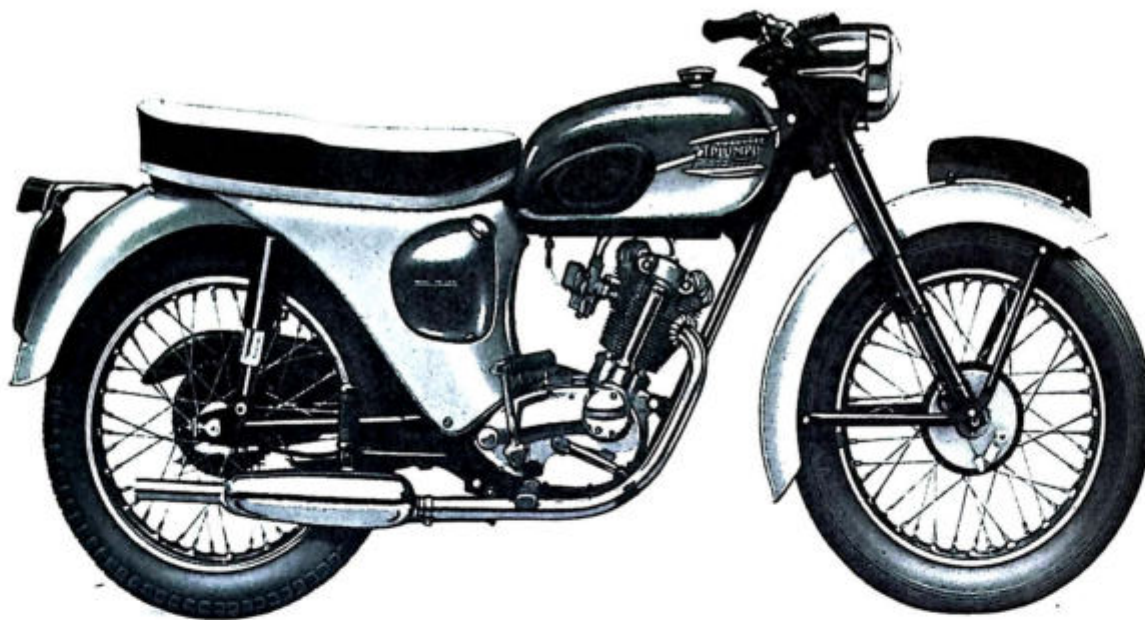

TIGER CUB (T20) TECHNICAL DATA

Bore and Stroke		63 x 64 mm. 2.480 x 2.520 ins.
Capacity		199 c.c. (12 cu. ins.)
Compression Ratio		7 : 1
Sparking Plug	Champion L7	
Carburetter		Amal Type 32
	Choke Size	11/16 in.
	Main Jet	85
	Throttle Valve	32/4
	Needle Position	2
	Needle Jet	0.103
	Pilot Jet	15
Gearbox Sprocket		17 teeth
Final Drive Sprocket		46 teeth
Chains	Front	$\frac{3}{8}$ in. x $\frac{7}{32}$ in. Duplex x 62 links
	Rear	$\frac{1}{2}$ in. x $\frac{1}{8}$ in. x 112 links
Capacities	Fuel Tank	3 galls. (13.5 litres)
	Oil Tank	2 $\frac{3}{4}$ pints (1.55 litres)
	Gearbox	$\frac{1}{2}$ pint (200 c.c.)
	Primary Chaincase	$\frac{1}{2}$ pint (200 c.c.)
	Front Forks (each leg)	$\frac{1}{8}$ pint (75 c.c.)
Brakes	Front and Rear Diameter	5 $\frac{1}{2}$ in. (13.97 cm.)
Tyre Size	Front and Rear	3.25 x 17

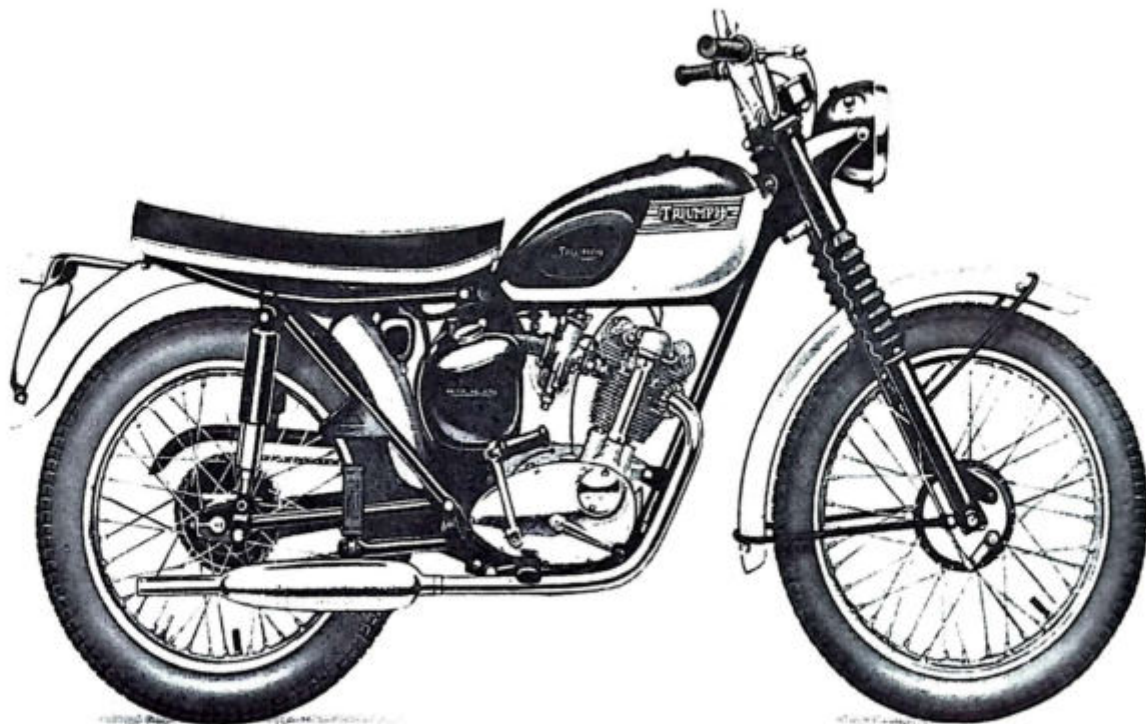

TIGER CUB (T20SS) TECHNICAL DATA

Bore and Stroke		63 x 64 mm. 2-480 x 2-520 ins.
Capacity		199 c.c. (12 cu. ins.)
Compression Ratio		9 : 1
Sparking Plug	Champion L7	
Carburettor		Amal Monobloc
	Choke Size	$\frac{15}{16}$ in.
	Main Jet	140
	Needle Jet	·106
	Needle	Type C
	Throttle Valve	376/3
	Pilot Jet	20
Gearbox Sprocket		17 teeth
Final Drive Sprocket		48 teeth
Chains	Front	$\frac{3}{8}$ in. x $\frac{7}{32}$ in. Duplex x 62 links
	Rear	$\frac{1}{2}$ in. x $\frac{3}{16}$ in. x 113 links
Capacities	Fuel Tank	2 $\frac{5}{8}$ galls. (11.9 litres)
	Oil Tank	2 $\frac{3}{4}$ pints (1.55 litres)
	Gearbox	$\frac{1}{2}$ pint (200 c.c.)
	Primary Chaincase	$\frac{1}{2}$ pint (200 c.c.)
	Front Forks (each leg)	$\frac{1}{4}$ pint (150 c.c.)
Brakes	Front and Rear Diameter	5 $\frac{1}{2}$ in. (13.97 cm.)
Tyre Size	Front	3-00 x 19
	Rear	3-50 x 18

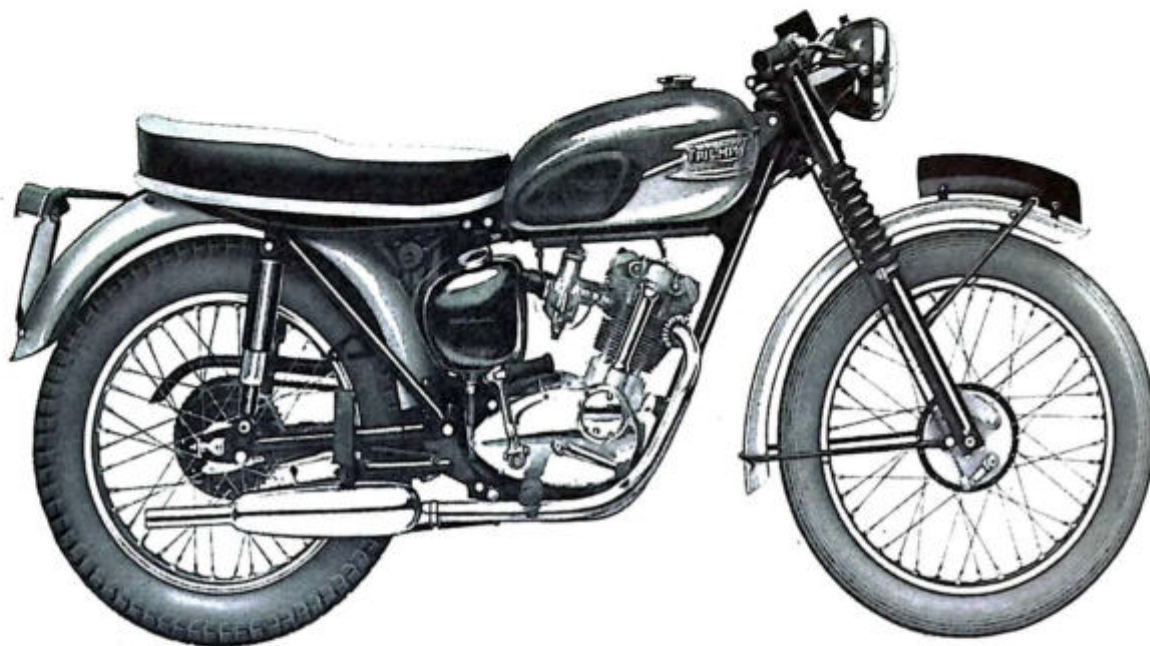

TIGER CUB (T20SH) TECHNICAL DATA

Bore and Stroke		63 x 64 mm. 2.480 x 2.520 ins.
Capacity		199 c.c. (12 cu. ins.)
Compression Ratio		9 : 1
Sparking Plug	Champion L7	
Carburetter		Amal Monobloc
	Choke Size	$\frac{1}{8}$ in.
	Main Jet	140
	Needle Jet	.106
	Needle	Type C
	Throttle Valve	376/3
	Pilot Jet	20
Gearbox Sprocket		17 teeth
Final Drive Sprocket		48 teeth
Chains	Front	$\frac{3}{8}$ in. x $\frac{7}{32}$ in. Duplex x 62 links
	Rear	$\frac{1}{2}$ in. x $\frac{3}{16}$ in. x 113 links
Capacities	Fuel Tank	3 galls. (13.5 litres)
	Oil Tank	2 $\frac{3}{4}$ pints (1.55 litres)
	Gearbox	$\frac{1}{2}$ pint (200 c.c.)
	Primary Chaincase	$\frac{1}{2}$ pint (200 c.c.)
	Front Forks (each leg)	$\frac{1}{4}$ pint (150 c.c.)
Brakes	Front and Rear Diameter	5 $\frac{1}{2}$ in. (13.97 cm.)
Tyre Size	Front	3.00 x 19
	Rear	3.50 x 18

CARTON PACK LIST

The following sub-assemblies are supplied in carton packs under the C.P. part number stated. The contents of these carton packs are preserved and will not deteriorate under adverse conditions.

Part No.			Contents
Big End Assembly			
C.P. 197	1	E4445	Connecting rod
	1	E4999	Crankpin
Brake Linings			
C.P. 128	2	W978	Brake linings
	14	W979	Rivets
Piston (T20)			
C.P. 141	1	E3358	Piston, C.R. 7 : 1
	1	E656	Compression ring (plain)
	1	E3048	Compression ring (taper)
	1	E3387	Oil control ring
	1	E1750	Gudgeon pin
	2	E1767	Circlip
Piston Rings (T20)			
C.P. 150	1	E656	Compression ring (plain)
	1	E3048	Compression ring (taper)
	1	E3387	Oil control ring
Piston (T20SS & T20SH)			
C.P. 172	1	E3958	Piston, C.R. 9 : 1
	1	E3959	Compression ring (plain)
	1	E3960	Compression ring (taper)
	1	E3961	Oil control ring
	1	E1750	Gudgeon pin
	2	E1767	Circlip
Piston Rings (T20SS & T20SH)			
C.P. 178	1	E3959	Compression ring (plain)
	1	E3960	Compression ring (taper)
	1	E3961	Oil control ring
Valve Guides			
C.P. 122	2	E3208	Valve guide
	2	E3209	Circlip
Valves			
C.P. 186	1	E3963	Inlet valve
	1	E3147	Exhaust valve
Valve Springs (T20)			
C.P. 123	2	E3214	Inner valve spring
	2	E3215	Outer valve spring

Part No.			Contents
Valve Springs (T20SS & T20SH)			
C.P. 185	2	E3965	Inner valve spring
	2	E3966	Outer valve spring
Steering Races			
C.P. 129	2	H835	Cup
	2	H833	Cone
	30	S70-3	Steel ball (¼ in. diam.)
Fork Service Pack (T20SS & T20SH)			
C.P. 168	2	H420	Rubber washer
	4	H430	Fibre washer
	2	H441	Upper bearing
	2	H443	Lower bearing
	2	H1062	Aluminium washer
	2	H1168	Oil seal
<hr/>			
Gasket Set	GS	T20/59	All models
De-Coke Gasket Set	D/GS	3	All models
<hr/>			

ALTERNATIVE SPROCKETS

Gearbox		Rear Wheel	
T1555/13	13 teeth	W1320	46 teeth
T1555/14	14 teeth	W984	48 teeth
T1555/15	15 teeth	W1074	50 teeth
T1513/16	16 teeth	W1075	52 teeth
T1513/17	17 teeth	W1076	54 teeth
T1513/18	18 teeth	W1078	58 teeth
T1568	19 teeth		

WORKSHOP TOOLS

Z 135	Distributor Gear Extractor
Z 139	Timing Pinion Extractor
D 485	Contact Breaker Extractor
D 486	Contact Breaker Reassembly Pilot
D 400	Clutch Extractor
D 538	Flywheel Tool
D 220	Fork 'C' Spanner (T20SS and T20SH)
D 526	Crankshaft bearing extractor tool

CRANKSHAFT ASSY. REF. N° 1

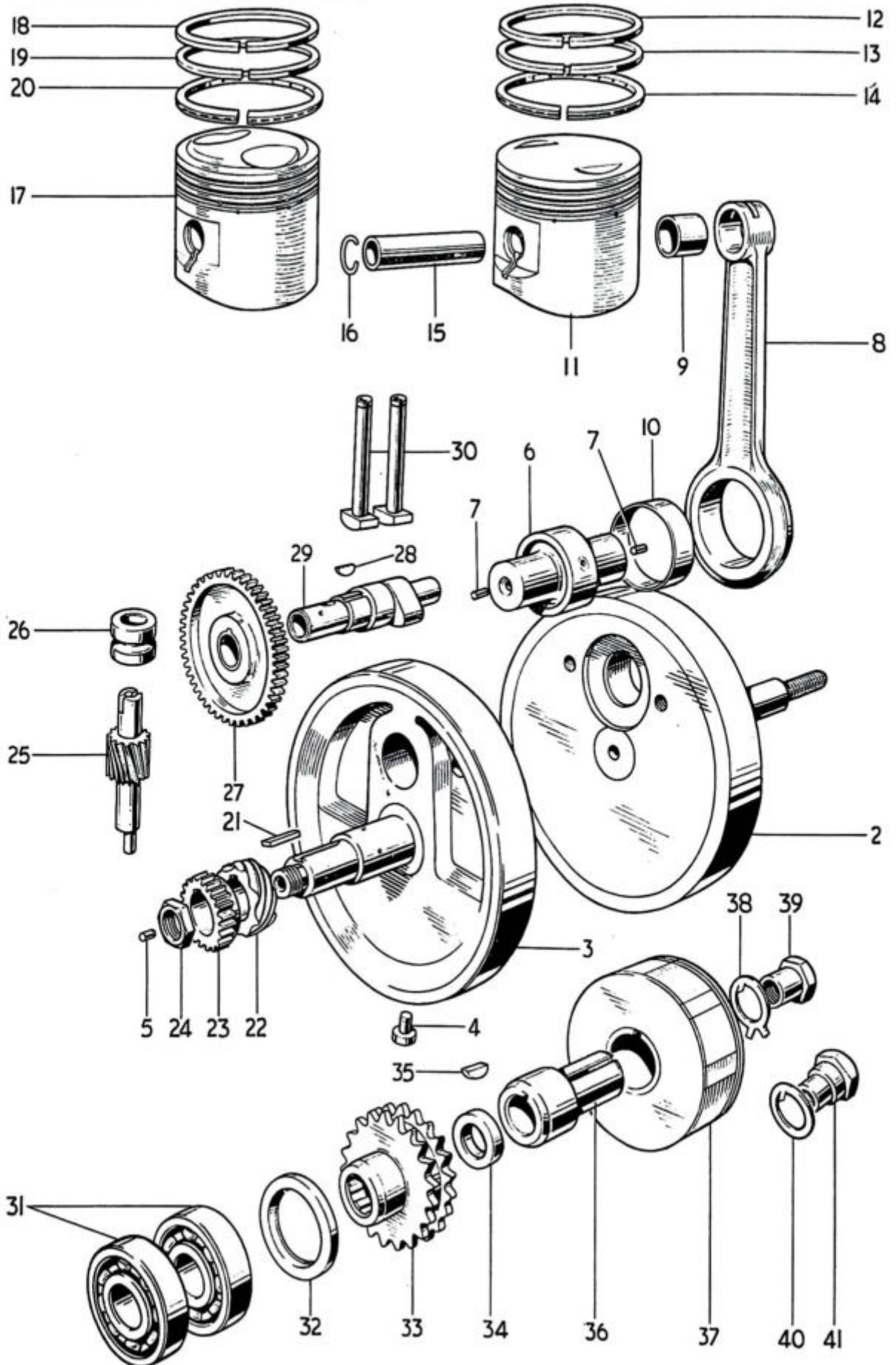

Fig. 1. CRANKSHAFT, PISTON AND TIMING GEARS

CRANKSHAFT, PISTON AND TIMING GEARS

									T20	T20SS	T20SH
1	E5323	CRANKSHAFT ASSEMBLY	1	1	1
2	E4436	Left flywheel	1	1	1
3	E4439	RIGHT FLYWHEEL	1	1	1
4	E3420	Screwed plug	1	1	1
5	E3902	Oilway plug	1	1	1
6	E4999	CRANKPIN	1	1	1
7	E3292	Oilway plug	2	2	2
8	E4445	Connecting rod	1	1	1
9	E1762	Small end bush	1	1	1
10	E4447	Big end bush (Export only)	1	1	1
11	CP141	PISTON COMPLETE, C.R. 7 : 1	1	-	-
12	E656	Compression ring	1	-	-
13	E3048	Taper compression ring	1	-	-
14	E3387	Oil control ring...	1	-	-
15	E1750	Gudgeon pin	1	-	-
16	E1767	Circlip	2	-	-
17	†CP172	PISTON COMPLETE, C.R. 9 : 1	-	1	1
18	E3959	Compression ring	-	1	1
19	E3960	Taper compression ring	-	1	1
20	E3961	Oil control ring...	-	1	1
15	E1750	Gudgeon pin	-	1	1
16	E1767	Circlip	-	2	2
21	E4453	Key	1	1	1
22	E5260	Distributor drive gear	1	1	1
23	E4451	Timing pinion	1	1	1
24	F2725	Nut	1	1	1
25	E4698	Oil pump drive shaft	1	1	1
26	E4693	Oil pump shaft bush	1	1	1
27	E3185	Camshaft pinion	1	1	1
28	E3184	Camshaft key	1	1	1
29	E4869	Camshaft c/w peg	1	-	-
29	E4870	Camshaft c/w peg	-	1	1
30	E3285	Tappet...	2	2	2
31	E3152	Main bearing	2	2	2
32	E3379	Oil seal	1	1	1
33	E3912	Engine sprocket (19 teeth Duplex)	1	1	1
34	E4458	Spacing washer	1	-	1
35	E4455	Key	1	1	1
36	E4454	Adaptor sleeve	1	1	1
37	54213903	Rotor, RM18	1	-	1
37	54213901	Rotor, RM19	-	1	-
38	E4058	Tab washer	1	-	1
39	E3971	Nut	1	-	1
40	E3975	Tab washer	-	1	-
41	E4503	Nut	-	1	-

† Note: Export models T20SC and TR20 use CP141

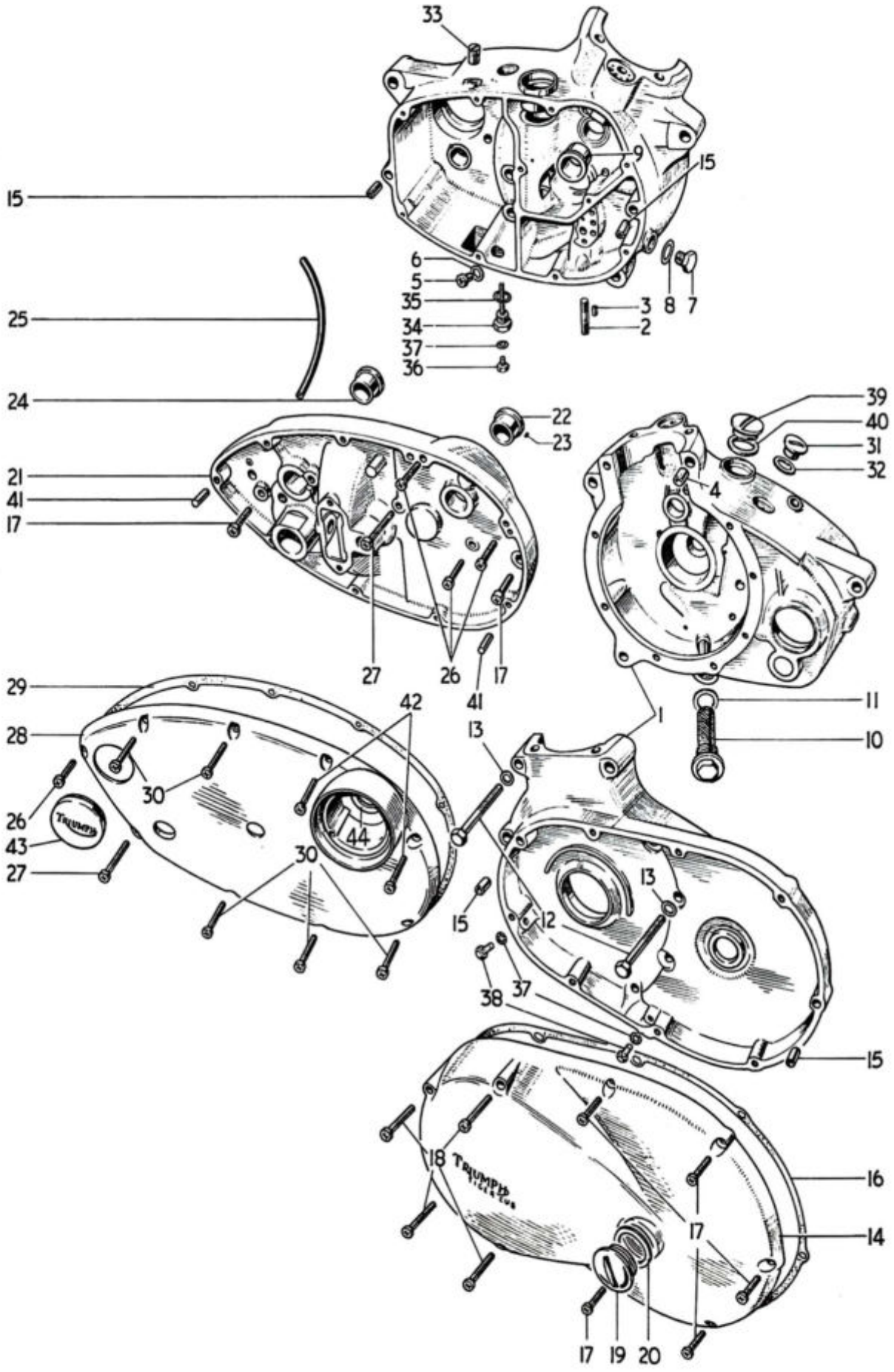

Fig. 2. CRANKCASE

CRANKCASE

											T20	T20SS	T20SH
1	E4087/4668	CRANKCASE	1	1	1
2	E3171	Oil junction block stud	1	1	1
3	E3169	Oil junction block dowel	1	1	1
4	E4121	Hollow dowel	1	1	1
5	T1553	Screwed plug ($\frac{3}{8}$ in. U.H.)	1	1	1
6	E2441	Copper washer	1	1	1
7	E2615	Screwed plug	1	1	1
8	E1335	Copper washer	1	1	1
9	E3175	Camshaft bush	1	1	1
10	E4094	Crankshaft filter	1	1	1
11	E2570	Fibre washer	1	1	1
12	E4098	Bolt ($1\frac{1}{4}$ in. U.H.)	9	9	9
13	S25-3	Plain washer	9	9	9
14	E4089	Left outer cover	1	1	1
15	T989	Hollow dowel	4	4	4
16	E4871	Joint washer	1	1	1
17	E3204	Screw (1 in. U.H.)	7	7	7
18	E4096	Screw ($2\frac{3}{16}$ in. U.H.)...	4	4	4
19	E732	Filler plug	1	1	1
20	NE507	Fibre washer	1	1	1
21	E4787	RIGHT INNER COVER	1	1	1
22	E4666	Camshaft bush	1	1	1
23	E3172	Peg	1	1	1
24	T1147	Mainshaft bush	1	1	1
25	F3775	Breather pipe	1	1	1
26	E3220	Screw ($1\frac{1}{16}$ in. U.H.)...	4	4	4
27	E3221	Screw ($1\frac{1}{8}$ in. U.H.)	2	2	2
28	E4637	Right outer cover	1	1	1
29	E4872	Joint washer	1	1	1
30	E3231	Screw ($1\frac{3}{8}$ in. U.H.)	7	7	7
31	T1599	Filler plug	1	1	1
32	E1465	Fibre washer	1	1	1
33	E4048	Blanking plug	-	1	1
34	T1112	Drain plug (with level tube)	1	1	1
35	T1257	Fibre washer	1	1	1
36	T361	Level plug	1	1	1
37	WE170	Fibre washer	3	3	3
38	DS57	Screwed plug	2	2	2
39	E4587	Blanking plug	1	1	1
40	E4593	Fibre washer	1	1	1
41	E4172	Hollow dowel	2	2	2
42	E4638	Outer cover screw ($\frac{5}{8}$ in. U.H.)	2	2	2
43	H1466	Clutch cable access grommet	1	1	1
44	E4568	Oil seal	1	1	1

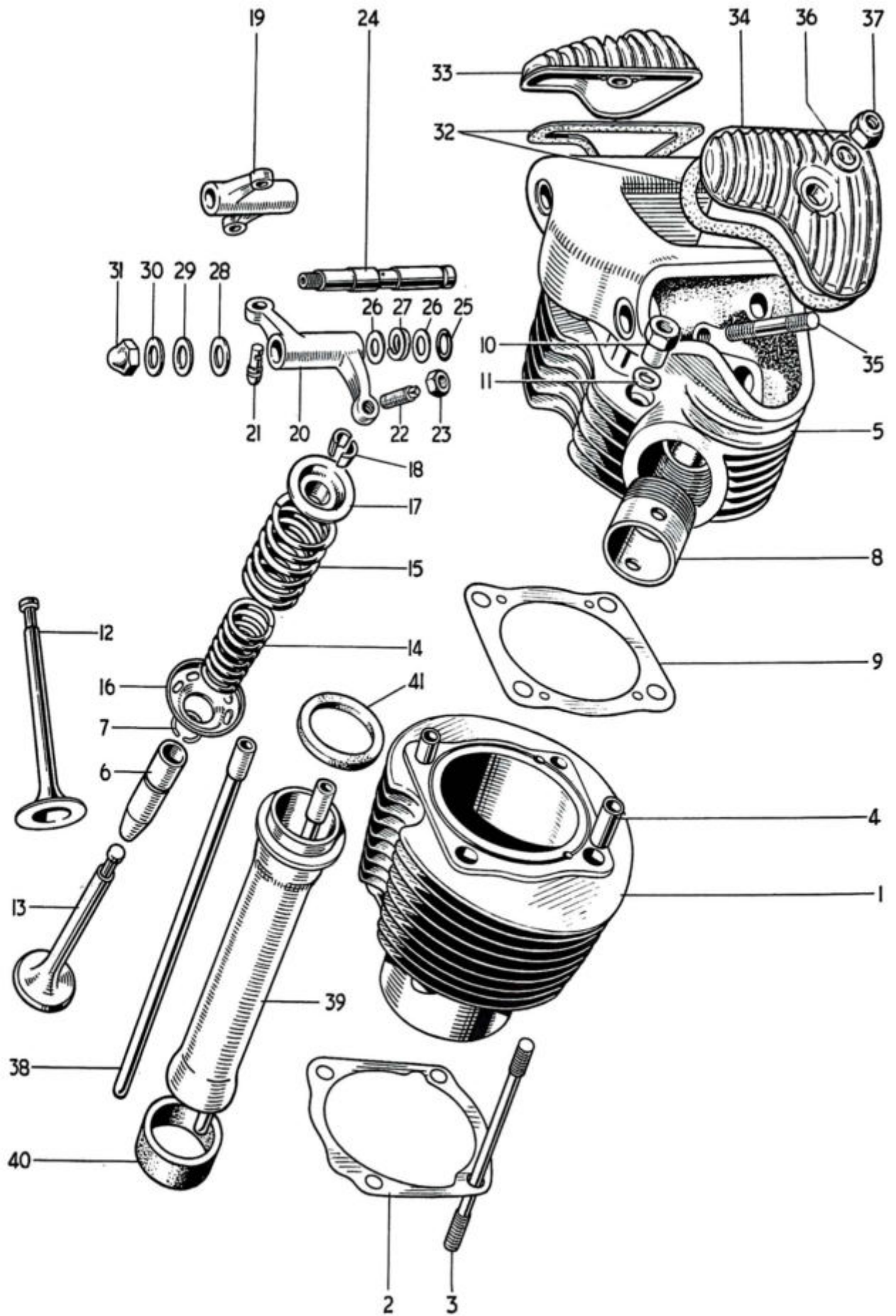

Fig. 3. CYLINDER BARREL AND HEAD

CYLINDER BARREL AND HEAD

										T20	T20SS	T20SH
1	E3385	Cylinder Barrel	1	1	1
2	E4037	Cylinder base washer	1	1	1
3	E3170	Crankcase to cylinder head stud (4 $\frac{1}{2}$ in. O.A.)	4	4	4
4	E3386	Cylinder head dowel	2	2	2
5	E4049A	CYLINDER HEAD C/W GUIDES	1	1	1
6	E3208	Valve guide	2	2	2
7	E3209	Valve guide circlip	2	2	2
8	E3207	Exhaust pipe adaptor	1	1	1
9	E3217	Cylinder head gasket	1	1	1
10	E4103	Nut	4	4	4
11	E3446	Plain washer	4	4	4
12	E3963	Inlet valve	1	1	1
13	E3147	Exhaust valve	1	1	1
14	E3214	Inner valve spring	2	-	-
14	E3965	Inner valve spring (red)	-	2	2
15	E3215	Outer valve spring	2	-	-
15	E3966	Outer, valve spring (red)	-	2	2
16	E3213	Bottom cup	2	-	-
16	E3964	Bottom cup	-	2	2
17	E3301	Top collar	2	2	2
18	WE259A	Split cotter	4	4	4
19	E3251	INLET ROCKER	1	1	1
20	E3252	EXHAUST ROCKER	1	1	1
21	E3222	Rocker ball pin	2	2	2
22	E3223	Adjuster pin	2	2	2
23	GS662	Nut	2	2	2
24	E3225	Rocker spindle	2	2	2
25	E3253	Sealing ring	2	2	2
26	E2534	Thrust washer $\frac{7}{16}$ in.	4	4	4
27	E3224	Thackeray washer	2	2	2
28	E2594	Thrust washer $\frac{3}{8}$ in.	2	2	2
29	E1335	Copper washer $\frac{3}{8}$ in....	2	2	2
30	E3249	Copper washer $\frac{5}{16}$ in.	2	2	2
31	H400	Domed nut	2	2	2
32	E3226	Joint washer	2	2	2
33	E4648	Inlet rocker cover	1	1	1
34	E4649	Exhaust rocker cover	1	1	1
35	E3210	Stud (2 $\frac{5}{16}$ in. O.A.)	2	2	2
36	E2441	Copper washer	2	2	2
37	E3290	Self-locking nut	2	2	2
38	E3372	Push rod	2	2	2
39	E3537	Cover tube	1	1	1
40	E3391	Lower joint washer	1	1	1
41	E3540	Upper joint washer	1	1	1

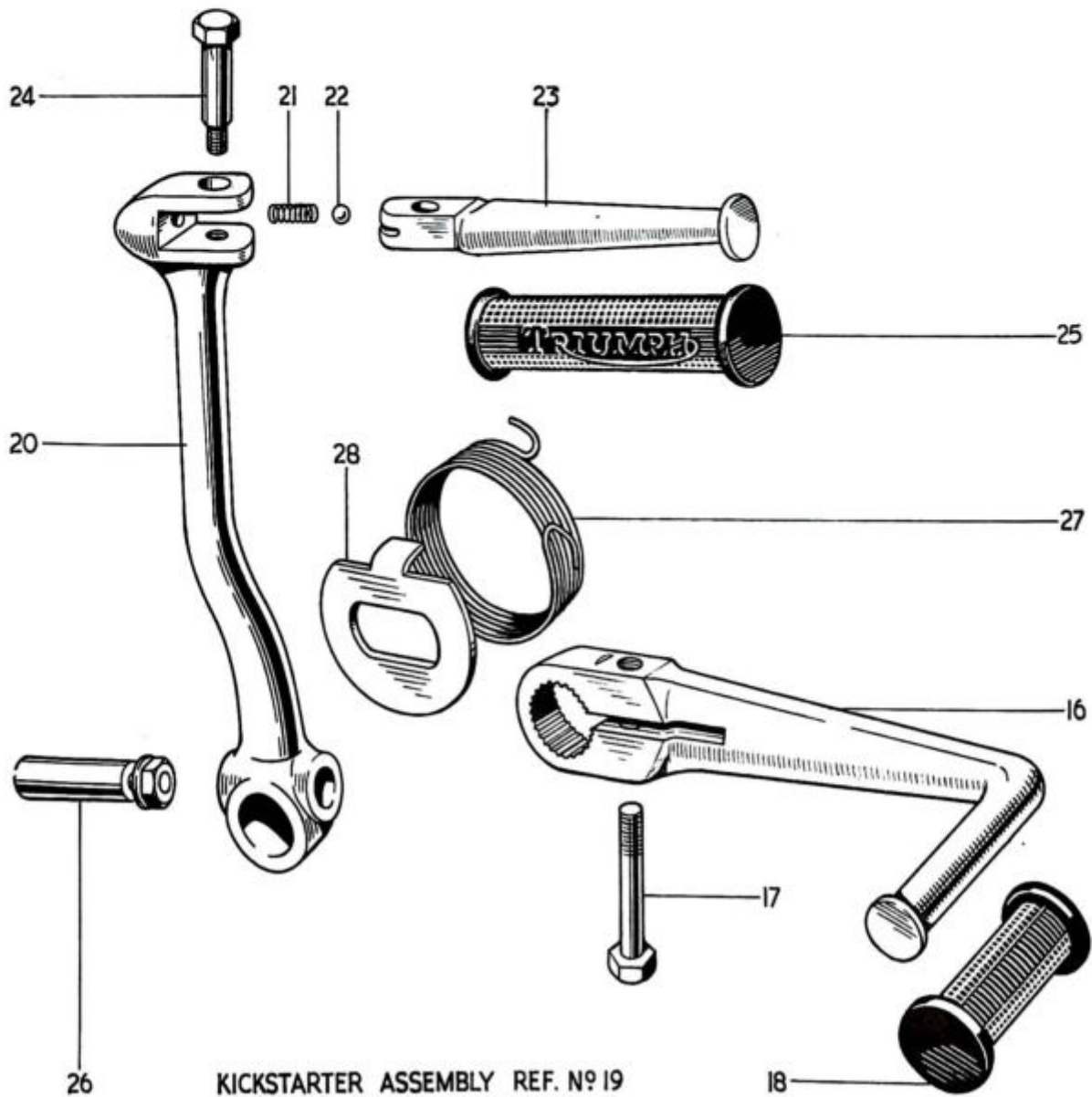
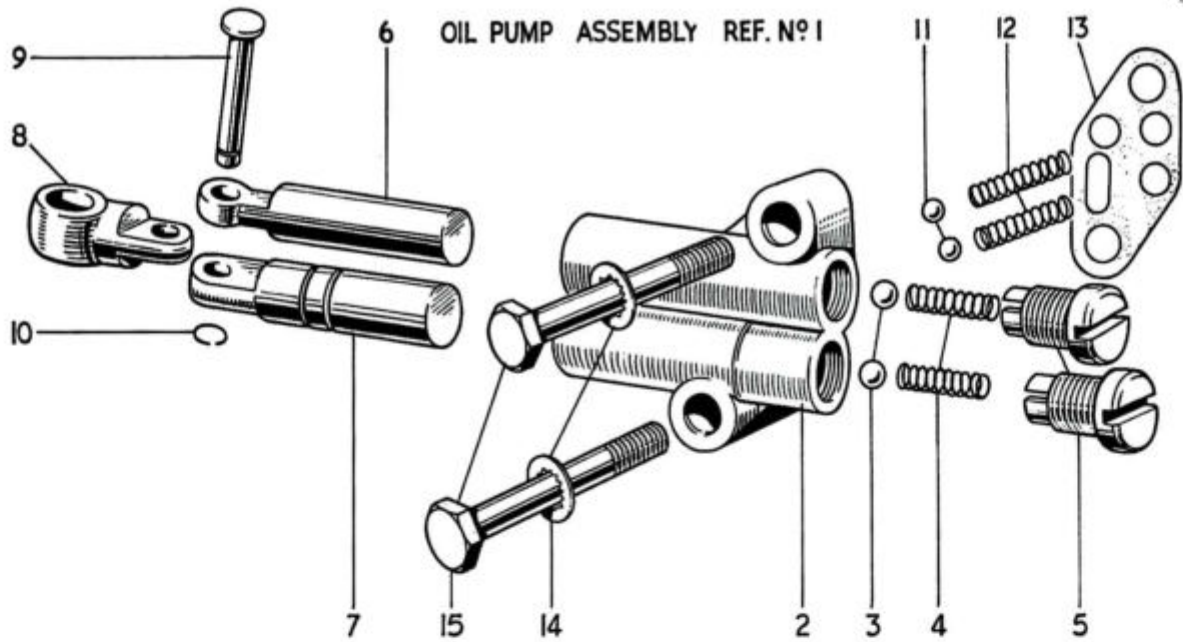

Fig. 4. OIL PUMP AND CONTROL PEDALS

OIL PUMP AND CONTROL PEDALS

										T20	T20SS	T20SH
1	E4402	OIL PUMP ASSEMBLY	1	1	1
2	E4403	Pump body	1	1	1
3	S70-4	Steel ball ($\frac{3}{16}$ in. diam.)	2	2	2
4	E4404	Spring	2	2	2
5	E4212	Plug	2	2	2
6	E4210	Feed plunger	2	2	2
7	E4211	Scavenge plunger	1	1	1
8	E3195	Connecting rod	1	1	1
9	E3412	Pin	1	1	1
10	E3413	Circlip	1	1	1
11	T1124	Auxiliary valve ball ($\frac{5}{32}$ in. diam.)	2	2	2
12	E4404	Spring	2	2	2
13	E3188	Joint washer	1	1	1
14	GS299	Serrated washer	2	2	2
15	E3197	Bolt ($\frac{1}{8}$ in. U.H.)	2	2	2
16	T1164	Gearchange pedal	1	1	1
17	F1369	Bolt ($\frac{5}{8}$ in. U.H.)	1	1	1
18	T449	Pedal rubber	1	1	1
19	T1679	KICKSTARTER ASSEMBLY	1	1	1
20	T1680	Crank	1	1	1
21	T1167	Spring	1	1	1
22	S70-3	Steel ball ($\frac{1}{4}$ in. diam.)	1	1	1
23	T1168	Pedal	1	1	1
24	T1169	Pivot bolt	1	1	1
25	F1814	Pedal rubber	1	1	1
26	T1222	Cotter pin c/w nut and washer	1	1	1
27	T1162	Kickstarter return spring	1	1	1
28	T1163	Return spring plate	1	1	1

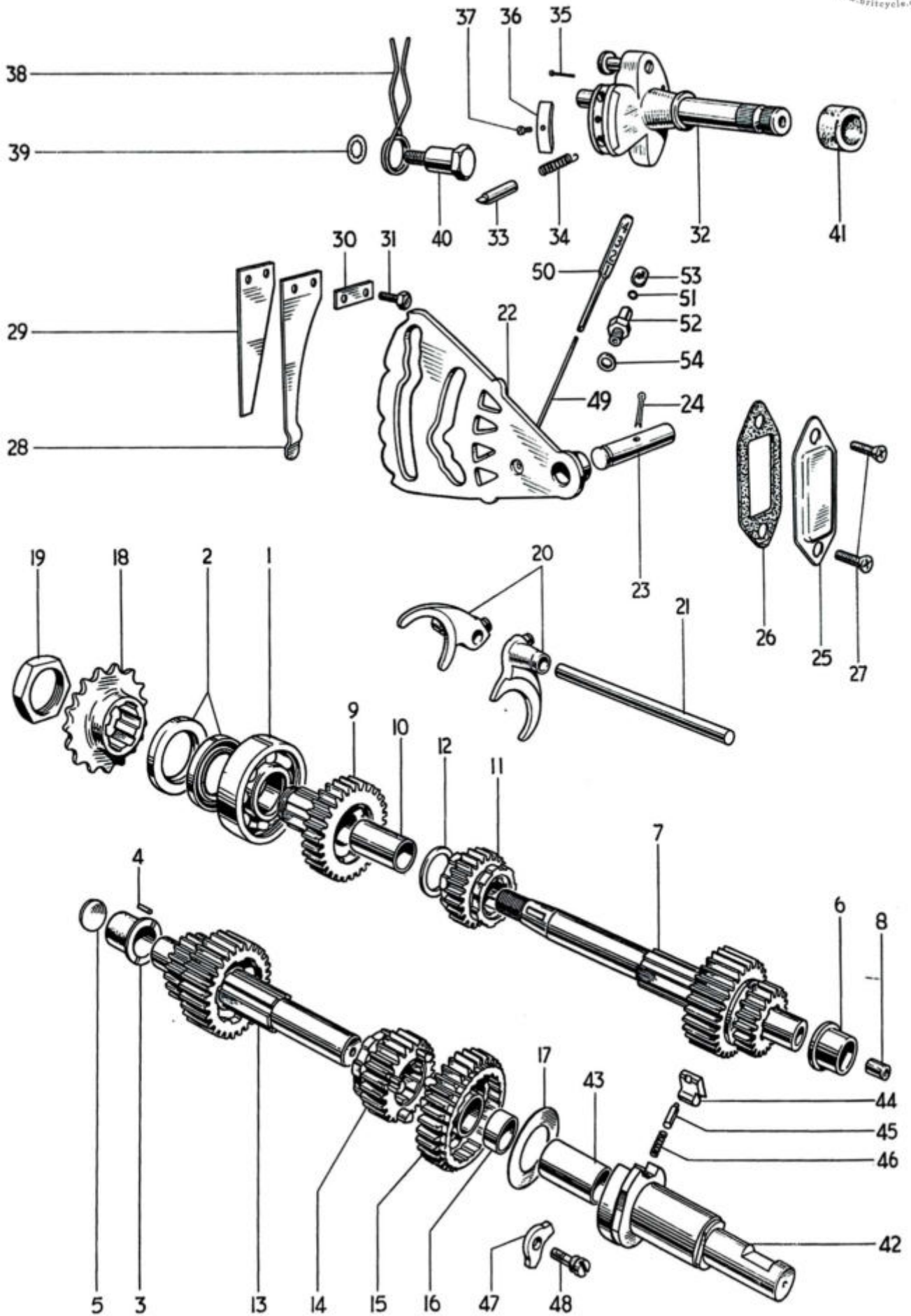

Fig. 5. GEARBOX SHAFTS AND GEARS

Ref. No.	Part No.	DESCRIPTION	QUANTITY		
			T20	T20SS	T20SH
1	T1070	High gear bearing	1	1	1
2	H1168	Oil seal	2	2	2
3	T1073	Layshaft bearing bush	1	1	1
4	E3172	Peg	1	1	1
5	T1269	Blanking disc	1	1	1
6	T1147	Mainshaft bush	1	1	1
7	T1588	MAINSHAFT CLUSTER	1	1	1
8	T1085	Clutch rod bush	1	1	1
9	T1514	HIGH GEAR (28T) Std.	1	-	-
9	T1565	HIGH GEAR (27T) C.R.	-	1	1
10	T1515	High gear bush	1	1	1
11	T1089	Mainshaft second gear	1	1	1
12	T1090	Mainshaft thrust ring	1	1	1
13	T1591	Layshaft cluster (17T) Std.	1	-	-
13	T1594	Layshaft cluster (18T) C.R.	-	1	1
14	T1094	Layshaft third gear	1	1	1
15	T1095	LAYSHAFT LOW GEAR	1	1	1
16	T1097	Low gear bush	1	1	1
17	T1274	Pawl retaining disc	1	1	1
18	†T1513/17	Gearbox sprocket (17 teeth)	1	1	1
19	T1082	Sprocket nut	1	1	1
20	T1098	Selector fork	2	2	2
21	T1102	Selector fork spindle	1	1	1
22	T1066	Camplate	1	1	1
23	T1069	Camplate spindle	1	1	1
24	$\frac{3}{32}$ in. x $\frac{3}{4}$ in.	Split pin	1	1	1
25	T1149	Cover plate	1	1	1
26	T1148	Joint washer	1	1	1
27	T1150	Screw (0.41 in. U.H.)	2	2	2
28	T1248	Index spring	1	1	1
29	T1249	Supplementary index spring	1	1	1
30	T1180	Lockplate	1	1	1
31	T1076	Screw ($\frac{3}{8}$ in. U.H.)	2	2	2
32	T1673	GEARCHANGE QUADRANT	1	1	1
33	T1184	Plunger	2	2	2
34	T1278	Spring	2	2	2
35	T1277	Peg	2	2	2
36	T1675	Keeper plate	1	1	1
37	T1676	Screw	1	1	1
38	T1109	Return spring	1	1	1
39	E2287	Serrated washer	1	1	1
40	T1077	Bolt	1	1	1
41	T1181	Felt washer	1	1	1

(continued on page 25)

† TR20 uses T1513/16 (16T)

For alternative sprockets see Page 11

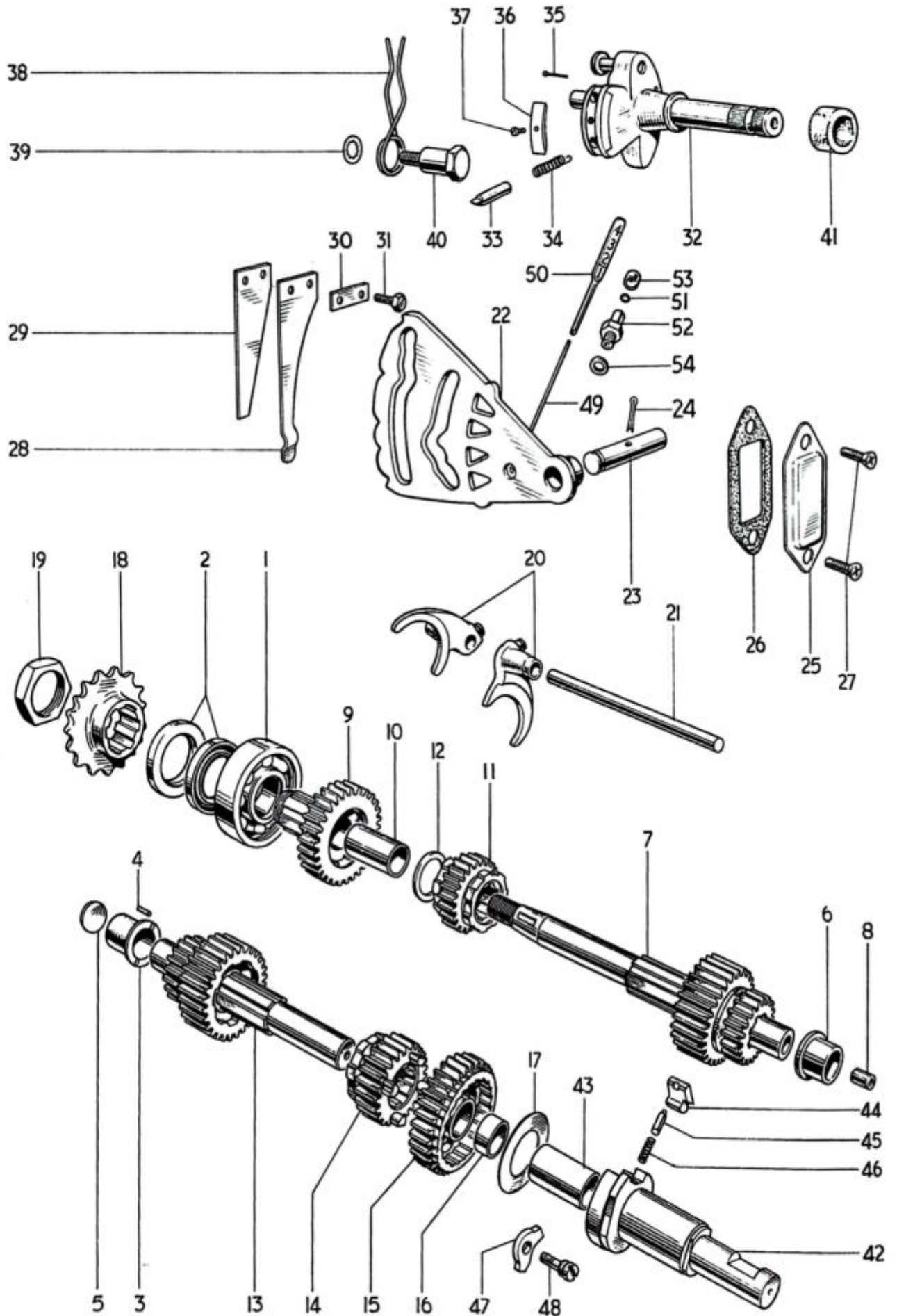

Fig. 5. GEARBOX SHAFTS AND GEARS

GEARBOX SHAFTS AND GEARS— (continued)

										T20	T20SS	T20SH
42	T1279	KICKSTARTER SPINDLE	1	1	1
43	T1118	Bush	1	1	1
44	T1281	Pawl	1	1	1
45	T1282	Plunger	1	1	1
46	T1161	Spring	1	1	1
47	T1157	Stop plate	1	1	1
48	T1158	Screw	1	1	1
49	E4703	Rod gear indicator	1	-	-
50	E4702	Gear indicator	1	-	-
51	E4193	"O" Ring	1	-	-
52	E4701	Sleeve nut	1	-	-
53	E4783	Cap	1	-	-
54	PT104B	Fibre washer	1	-	-

EXTRA CLOSE RATIO GEARS

7	T1819	Mainshaft cluster (E.C.R.)	} Extra close ratio gear set.	} Fitted to:- Export	} T20SR
9	T1652	Mainshaft high gear (E.C.R.)			
11	T1089	Mainshaft second gear (Std.)			
13	T1657	Layshaft cluster (E.C.R.)			
14	T1659	Layshaft third gear (E.C.R.)			
15	T1095	Layshaft low gear (Std.)			

WIDE RATIO GEARS

7	T1588	Mainshaft cluster (Std.)	} Wide ratio gear set as fitted to:- Export T20SC.
9	T1596	Mainshaft high gear (W.R.)	
11	T1089	Mainshaft second gear (Std.)	
13	T1728	Layshaft cluster (W.R.)	
14	T1094	Layshaft third gear (Std.)	
15	T1095	Layshaft low gear (Std.)	

OPERATING LEVER ASSEMBLY REF. N° 1
CLUTCH COMPLETE REF. N° 13

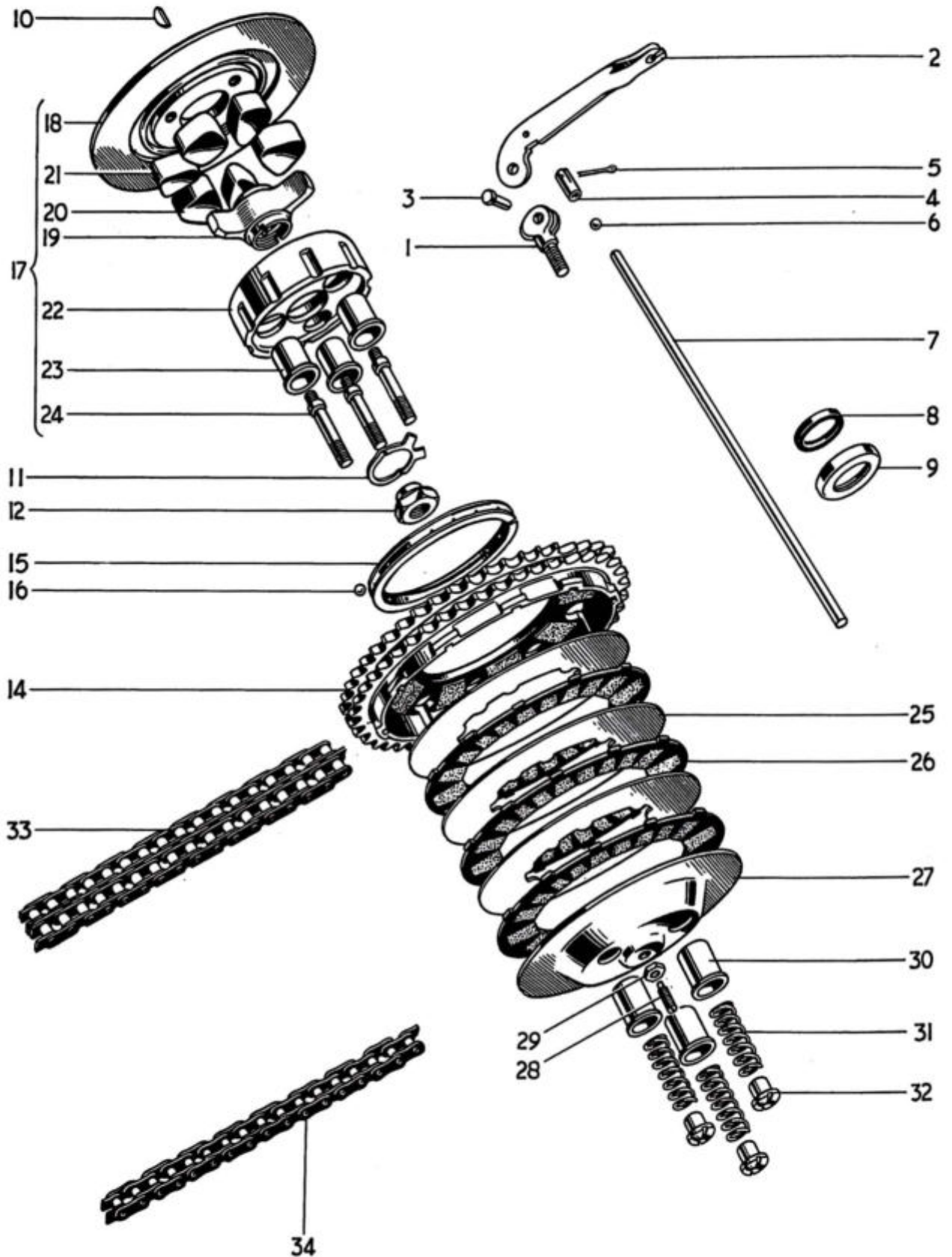

Fig. 6. CLUTCH AND CHAINS

CLUTCH AND CHAINS

										T20	T20SS	T20SH
1	T1233	CLUTCH OPERATING LEVER ASSEMBLY	1	1	1
2	T1235	Lever	1	1	1
3	T1236	Pin	1	1	1
4	T1155	Cup	1	1	1
5	$\frac{1}{8} \times \frac{3}{8}$ in.	Split pin	1	1	1
6	T1124	Steel ball ($\frac{5}{32}$ in. diam.)	1	1	1
7	T1140	Clutch operating rod	1	1	1
8	E3932	Mainshaft oil seal	1	1	1
9	E3933	Oil seal retainer	1	1	1
10	T1119	Key	1	1	1
11	T1347	Tab washer	1	1	1
12	T1348	Nut	1	1	1
13	T1924	CLUTCH COMPLETE	1	1	1
14	T1509	Sprocket and housing (48 teeth)	1	1	1
15	T1264	Bearing ring	1	1	1
16	T1124	Steel ball ($\frac{5}{32}$ in. diam.)	16	16	16
17	T1667	SHOCK ABSORBER	1	1	1
18	T1668	Back plate	1	1	1
19	T1346	Spider	1	1	1
20	T1132	Drive rubber (large)	3	3	3
21	T1318	Rebound rubber (small)	3	3	3
22	T1314	Centre	1	1	1
23	T1669	Cup	3	3	3
24	T1670	Pin	3	3	3
25	T1315	Driven plate	3	3	3
26	T1503	Driving plate c/w linings	3	3	3
27	T1925	Pressure plate	1	1	1
28	T1256	Adjuster	1	1	1
29	GS662	Nut	1	1	1
30	T1927	Cup	3	3	3
31	T1742	Spring	3	3	3
32	T1146	Nut	3	3	3
33	D382	Primary chain ($\frac{3}{8}$ in. Duplex x 62 links)	1	1	1
34	D277	Rear chain ($\frac{1}{2}$ in. x $\frac{3}{16}$ in. x 112 links)	1	-	-
34	D430	Rear chain ($\frac{1}{2}$ in. x $\frac{3}{16}$ in. x 113 links)	-	1	1

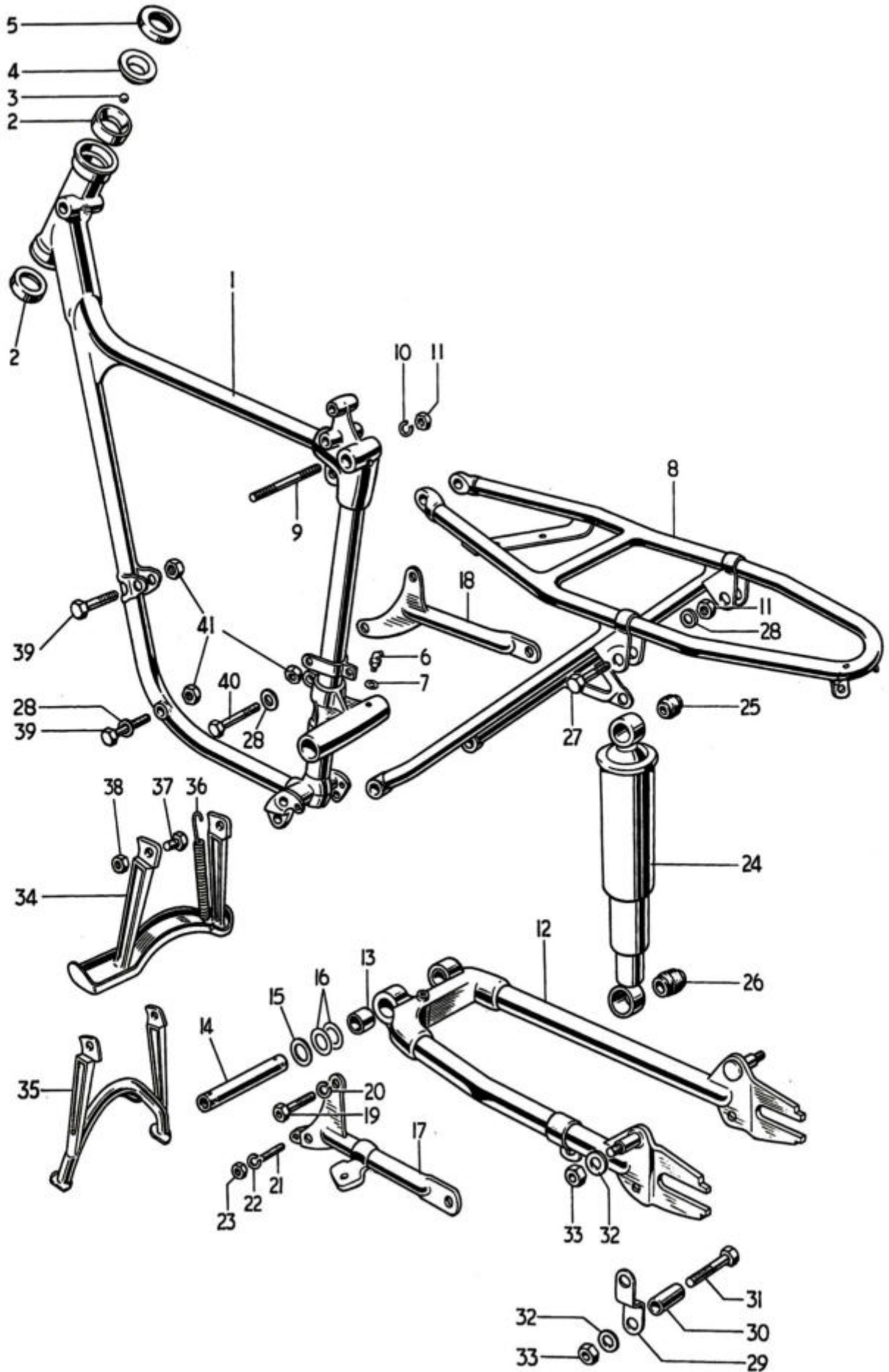

Fig. 7. FRAME COMPLETE

Ref. No.	Part No.	DESCRIPTION	QUANTITY		
			T20	T20SS	T20SH
FRAME COMPLETE					
1	F4594	Front frame	1	-	1
1	F5163	Front frame	-	1	-
2	H835	Steering race cup	2	2	2
3	S70-3	Steel ball ($\frac{1}{4}$ in. diam.)	30	30	30
4	H833	Top cone	1	1	1
5	H836	Dust cover	1	1	1
6	NW100	Grease nipple	1	1	1
7	WE170	Fibre washer	1	1	1
8	F4051	Rear frame	1	-	-
8	F4253	Rear frame	-	-	1
8	F5164	Rear frame	-	1	-
9	F4510	Stud ($4\frac{3}{8}$ in. O.A.)	1	-	-
9	E1023	Stud ($3\frac{5}{8}$ in. O.A.)	-	1	1
10	S26-1	Spring washer	2	2	2
11	P0172A	Nut	4	4	4
12	F4598	SWINGING FORK	1	1	1
13	F4076	Pivot bush	2	2	2
14	F4079	Spindle	1	1	1
15	F4078	Spacing washer	1	1	1
16	F4385	Shim, 0.003 in.	as required		
16	F4386	Shim, 0.005 in.	as required		
17	F4080	Left bracket	1	-	-
17	†F4278	Left bracket	-	1	1
18	†F4081	Right bracket... ..	1	1	1
19	F4509	Bolt ($1\frac{1}{2}$ in. U.H.)	2	-	-
19	F4087	Bolt ($1\frac{1}{2}$ in. U.H.)	-	2	2
20	PCW73A	Spring washer	2	2	2
21	E1396	Stud ($1\frac{1}{8}$ in. O.A.)	2	2	2
22	S26-3	Spring washer	2	2	2
23	S1-51	Nut	2	2	2
24	SC3/204	SUSPENSION UNIT	2	-	2
24	*640/545/23	SUSPENSION UNIT	-	2	-
25	9054/316A	Bonded bush	2	2	2
26	9054/316J	Bonded bush	2	2	2
27	F1760	Bolt ($1\frac{1}{8}$ in. U.H.)	2	2	2
28	S25-2	Washer	4	4	4
29	F4311	Bracket	-	2	2
30	F3207	Spacer	-	2	2
31	H622	Bolt ($1\frac{1}{2}$ in. U.H.)	-	2	2
32	E1330C	Plain washer	2	4	4
33	S1-52	Nut	2	4	4
34	F3763	Centre stand	1	-	-
35	F5041	Centre stand	-	1	1
36	F3747	Return spring	1	1	1
37	F3520	Pivot bolt	2	2	2
38	H193	Nut	2	2	2
39	F1245	Bolt ($1\frac{5}{8}$ in. U.H.)	2	2	2
40	F3191	Bolt ($2\frac{1}{8}$ in. U.H.)	1	1	1
41	F3955	Self-locking nut	3	3	3

* T20SC, TS20 and TR20 use 640/544/41

† TR20 uses F5158 left bracket and F4086 right bracket

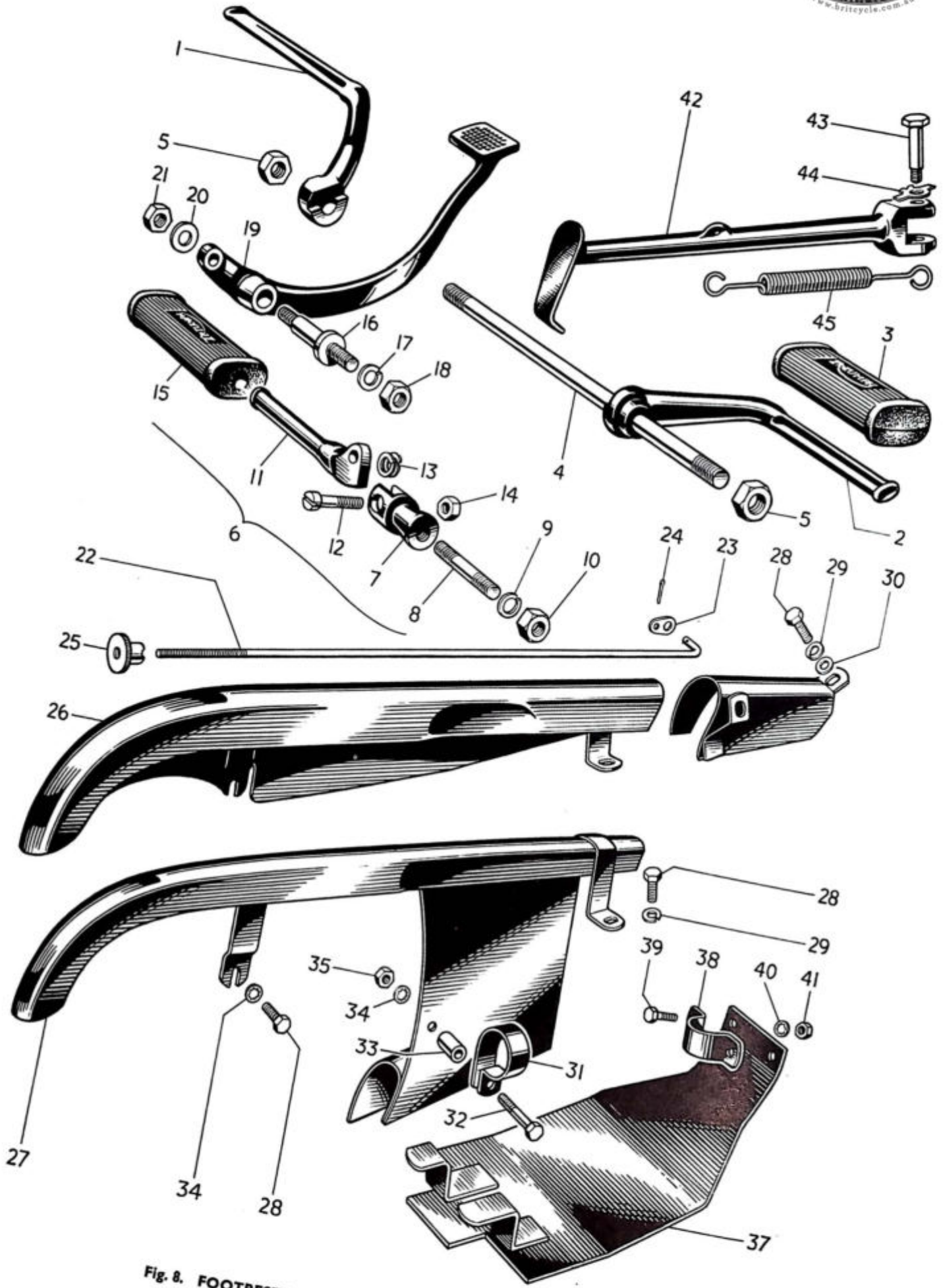

Fig. 8. FOOTRESTS, CHAINGUARD, PROPSTAND, ETC.

Ref. No. Part No. DESCRIPTION

FOOTRESTS, CHAINGUARD, PROPSTAND, ETC.

											T20	T20SS	T20SH
1	†F4383	Left footrest	1	1	1
2	†F3450	Right footrest	1	1	1
3	F1695	Pedal rubber	2	2	2
4	F3448	Footrest hanger rod (6 $\frac{3}{4}$ in. O.A.)	1	1	1
5	†H193	Nut	2	2	2
6	F4327	PILLION FOOTREST	2	2	2
7	F2268	Footrest hanger...	2	2	2
8	F4309	Stud (1 $\frac{3}{8}$ in. O.A.)	2	2	2
9	S26-1	Spring washer	2	2	2
10	P0172A	Nut	2	2	2
11	F1694	Pedal	2	2	2
12	F2271	Pivot bolt	2	2	2
13	F2277	Spring washer	2	2	2
14	S1-51	Nut	2	2	2
15	F1695	Pedal rubber	2	2	2
16	F4090	Brake pedal spindle	1	1	1
17	S26-1	Spring washer	1	1	1
18	P0172A	Nut	1	1	1
19	F4091	Brake pedal	1	1	1
20	S25-3	Plain washer	1	1	1
21	T224	Nut	1	1	1
22	†F4093	Brake rod	1	1	1
23	F3461	Washer	1	1	1
24	$\frac{1}{8}$ in. x $\frac{3}{8}$ in.	Split pin	1	1	1
25	F3463	Adjuster nut	1	1	1
26	F4089	Rear chainguard	1	-	-
27	F5053	Rear chainguard	-	1	1
28	DS57	Bolt ($\frac{7}{8}$ in. U.H.)	3	2	2
29	S26-2	Spring washer	2	1	1
30	S25-1	Plain washer	1	-	-
31	F4265	Clip	-	1	1
32	E2818	Bolt ($1\frac{5}{16}$ in. U.H.)	-	1	1
33	F4263	Distance piece	-	1	1
34	E1612	Serrated washer	-	1	1
35	F879	Nut	-	1	1
36	F4152	Front chainguard	1	-	-
37	F4258	Crankcase shield	-	1	-
38	F4260	Clip	-	1	-
39	DS57	Bolt ($\frac{7}{8}$ in. U.H.)	-	2	-
40	E1612	Serrated washer	-	2	-
41	F879	Nut	-	2	-
42	F4277	PROP STAND COMPLETE	1	1	1
43	F3097	Pivot bolt	1	1	1
44	F3096	Tab washer	1	1	1
45	F2610	Return spring	1	1	1

- † TR20 uses the following:
- 1. F5156 Left footrest 1
 - 2. F5157 Right footrest 1
 - 5. DS47 Nut 2
 - 22. F5161 Brake rod 1

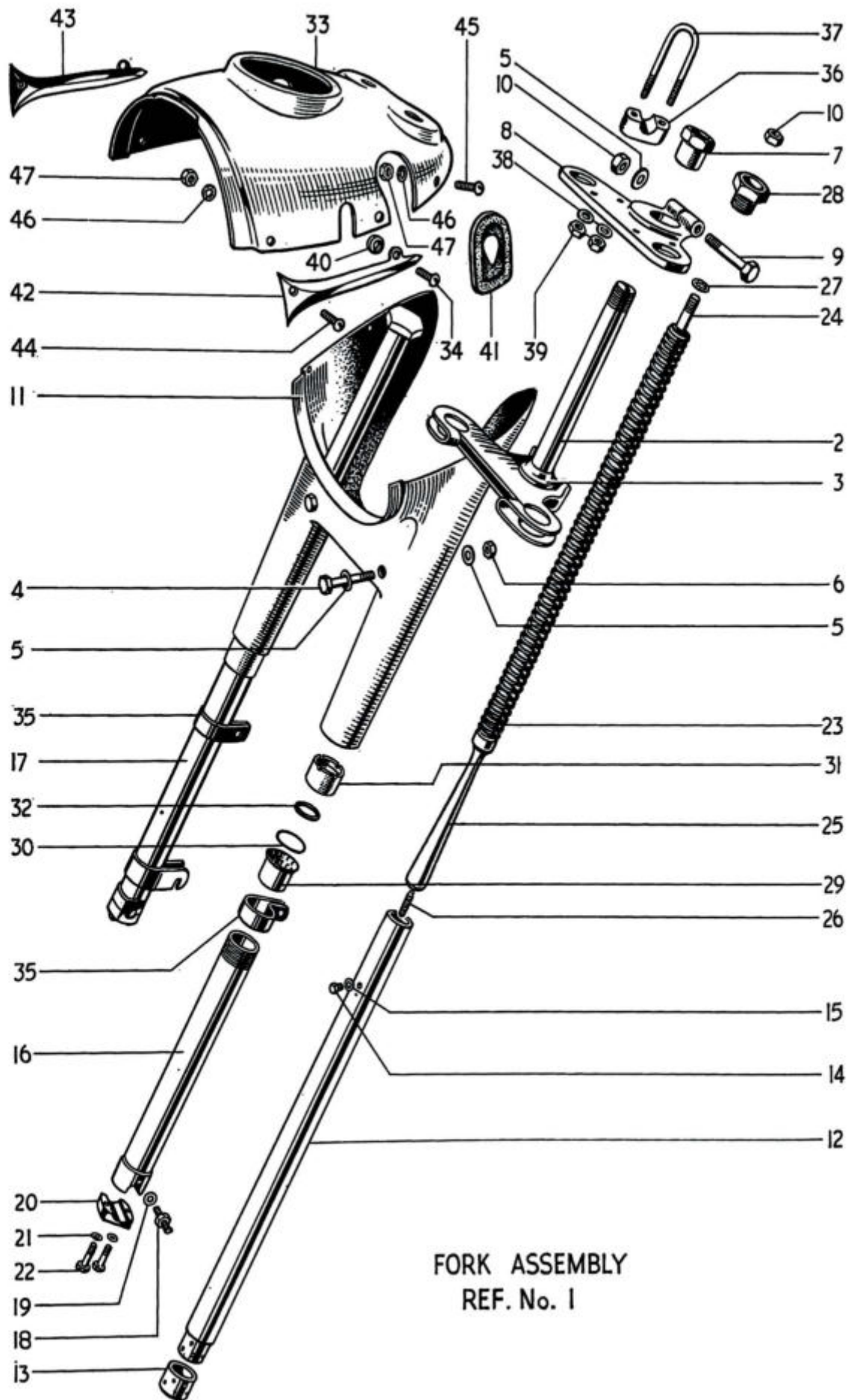

FORK ASSEMBLY
REF. No. 1

Fig. 9. TELESCOPIC FRONT FORK T20

TELESCOPIC FRONT FORK T20

											T20	
1	H1230	FORK ASSEMBLY	1
2	H1231	Middle lug and stem	1
3	H833	Bottom cone	1
4	H834	Pinch bolt (2 $\frac{3}{8}$ in. U.H.)	2
5	S25-3	Plain washer	5
6	H518	Nut	2
7	H840	Fork stem sleeve nut	1
8	H837	Top lug	1
9	H570	Pinch bolt (2 $\frac{1}{8}$ in. U.H.)	1
10	S1-51	Nut	3
11	H823	Nacelle bottom unit	1
12	H1035	STANCHION C/W BEARING	2
13	H845	Lower bearing	2
14	H519	Oil filler plug ($\frac{3}{16}$ in. U.H.)	2
15	H430	Fibre washer	2
16	H1040	LEFT BOTTOM MEMBER C/W CAP	1
17	H1043	RIGHT BOTTOM MEMBER C/W CAP	1
18	H1042	Oil drain stud ($\frac{3}{2}$ in. O.A.)	2
19	WE170	Fibre washer	2
20	H856	Spindle cap	2
21	E1612	Serrated washer	4
22	W932	Bolt (1 in. U.H.)	4
23	H1037	SPRING ASSEMBLY	2
24	H850	Stud (1 $\frac{5}{16}$ in. O.A.)	2
25	H1047	Restrictor rod	2
26	H1048	Stud (1 $\frac{7}{8}$ in. O.A.)	2
27	E2287	Serrated washer	2
28	H846	Cap nut	2
29	H1046	Top bearing	2
30	H862	Steel washer	2
31	H1045	Dust excluder sleeve nut	2
32	H1044	Oil seal	2
33	H1446	Nacelle top	1
34	H916	Screw ($\frac{3}{32}$ in. U.H.)	2
35	H873	Mudguard clip	2
36	H864	Handlebar support	2
37	H865	Handlebar "U" bolt	2
38	S25-13	Plain washer	4
39	F879	Nut	4
40	H961	Rubber grommet	3
41	H881	Rubber grommet	2
42	H877	Left motif	1
43	H878	Right motif	1
44	H688	Screw ($\frac{5}{16}$ in. U.H.)	3
45	H689	Screw ($\frac{1}{4}$ in. U.H.)	4
46	E2880	Serrated washer	4
47	H691	Nut	4

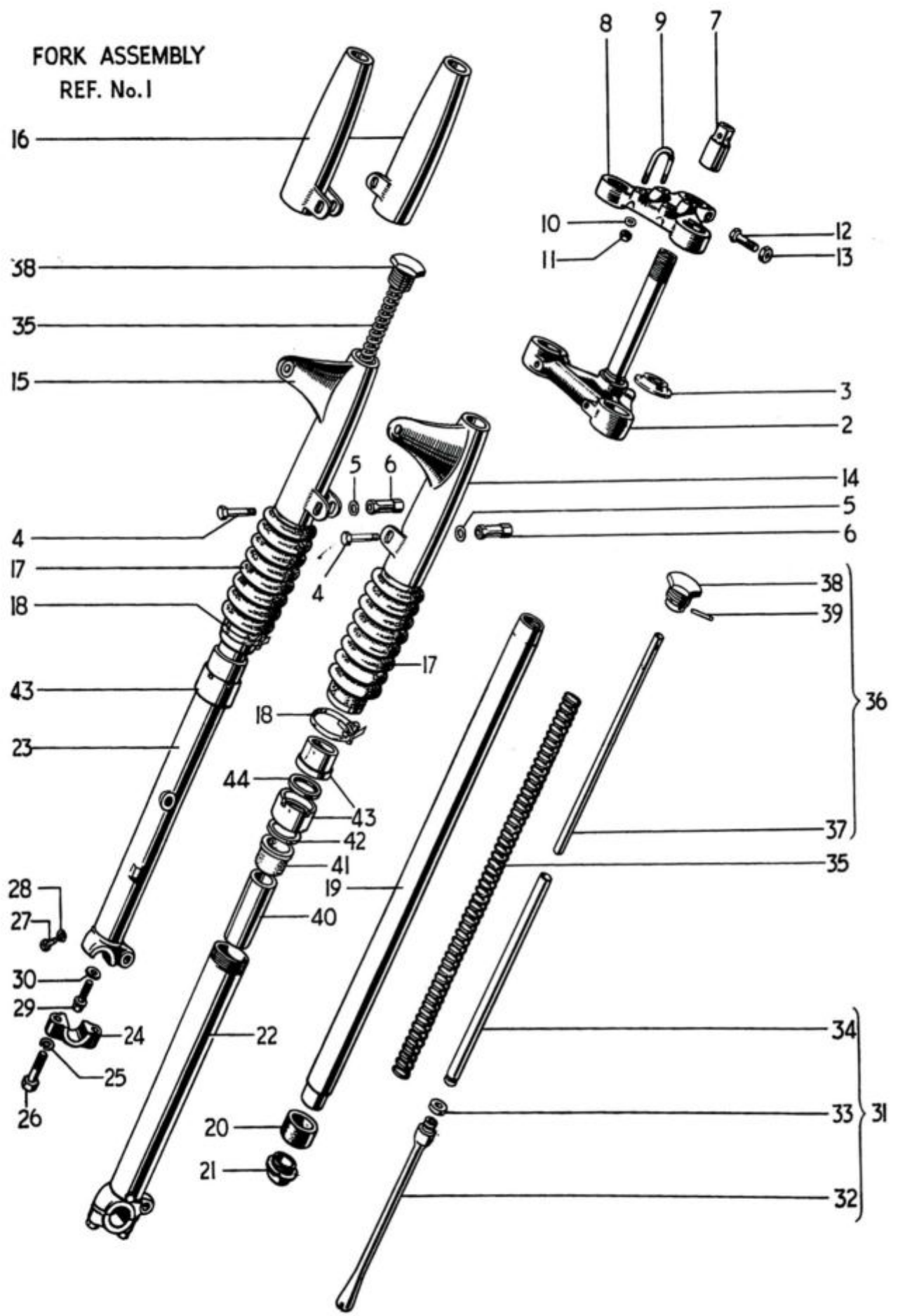

Fig. 10. TELESCOPIC FRONT FORK T20SS and T20SH

TELESCOPIC FRONT FORK T20SS AND T20SH

											T20SS	T20SH	
1	†H1592	FORK ASSEMBLY	1	1
2	H1257	Middle lug and stem	1	1
3	H833	Bottom cone	1	1
4	H941	Pinch bolt (2½ in. U.H.)	2	2
5	S25-2	Plain washer	2	2
6	‡H975	Nut	2	2
7	H1260	Fork stem sleeve nut	1	1
8	H1108	Top lug	1	1
9	H660	Handlebar "U" bolt	2	2
10	S25-3	Plain washer	4	4
11	E1310	Nut	4	4
12	F1760	Pinch bolt (1½ in. U.H.)	1	1
13	H379	Seated nut	1	1
14	H1261	Left top cover	1	1
15	H1262	Right top cover	1	1
16	*H1281	Top cover	A	A
17	H962	Telescopic gaiter	2	2
18	D340	Gaiter clip	2	2
19	H1280	STANCHION C/W BEARING	2	2
20	H443	Lower bearing	2	2
21	H1058	Bearing nut	2	2
22	H1117	LEFT BOTTOM MEMBER C/W CAP	1	1
23	H1118	RIGHT BOTTOM MEMBER C/W CAP	1	1
24	H1053	Spindle cap	2	2
25	S26-3	Spring washer	4	4
26	H1070	Bolt (1⅞ in. U.H.)	4	4
27	H1071	Drain plug	2	2
28	H430	Fibre washer	2	2
29	H1063	Flanged bolt (¾ in. U.H.)	2	2
30	H1062	Aluminium washer	2	2
31	H1124	RESTRICTOR ROD ASSEMBLY	2	2
32	H1061	Restrictor rod	2	2
33	H1060	Plain washer	2	2
34	H1125	Guide tube	2	2
35	H1434	Main spring—Red/Yellow	2	2
36	H1064A	CAP NUT ASSEMBLY	2	2
37	H1051	Guide tube	2	2
38	H1065A	Cap nut	2	2
39	H1066	Pin	2	2
40	H1126	Damping sleeve	2	2
41	H441	Top bearing	2	2
42	H431	Plain washer	2	2
43	H1474	DUST EXCLUDER SLEEVE NUT	2	2
44	H1461	Oil seal	2	2

† H1578 Fork assembly TS20 and TR20

‡ H1329 Nut 2 off used on Export TS20 model only

* H1281 Top cover not required on Export TS20 and TR20 model

H1435 Competition front number plate TR20

Ref. No. Part No.

DESCRIPTION

FRONT WHEEL T20

Ref. No.	Part No.	DESCRIPTION	QUANTITY
			T20
1	W1379	FRONT WHEEL COMPLETE	1
2	W1380	RIM, SPOKES AND HUB ASSEMBLY	1
3	W1397	Front wheel rim WM2-17	1
4	W1381	Spoke (10/12G x 7 ⁷ / ₁₆ in. 90°) c/w nipple	20
5	W1382	Spoke (10/12G x 5 ⁷ / ₈ in. 100°) c/w nipple	10
6	W1383	Spoke (10/12G x 5 ⁷ / ₈ in. 80°) c/w nipple	10
7	W965	Nipple	40
8	W1286	Hub and brake drum	1
9	W967	Wheel spindle	1
10	T530	Left bearing	1
11	W966	Dust cover	1
12	T532	Circlip	1
13	H826	Right bearing	1
14	W968	Retaining ring	1
15	W1065	Brake anchor plate	1
16	W977	BRAKE SHOE C/W LINING	2
17	W978	Brake lining	2
18	W979	Brass rivet	12
19	W200	Shoe return spring	2
20	W1128	Brake cam	1
21	W1133	Brake cam lever	1
22	S25-71	Plain washer	1
23	T224	Nut	1
24	W1093	Anchor plate nut	1
25	S26-1	Spring washer	1
26	S1-52	Nut	1

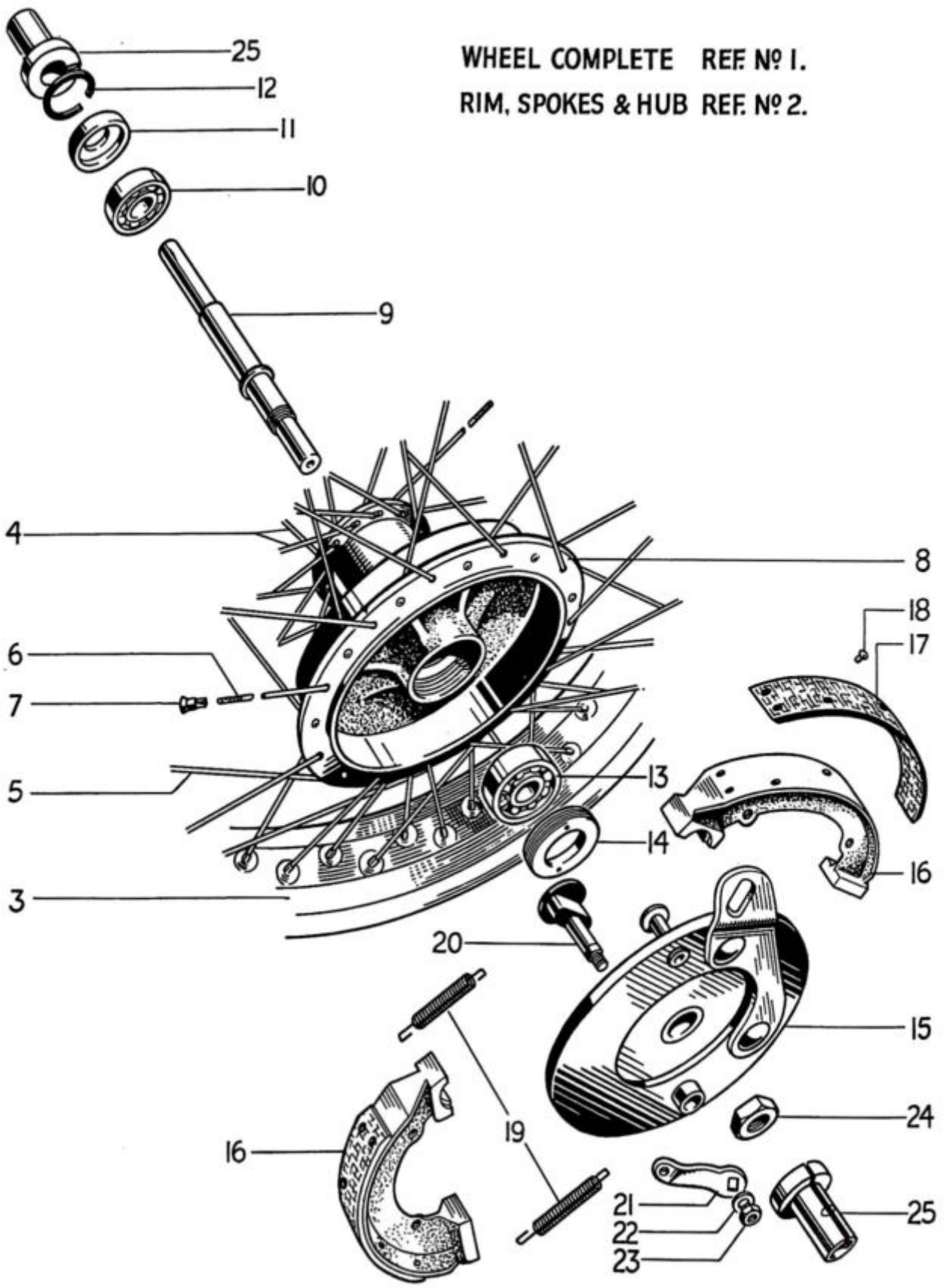

Fig. 12. FRONT WHEEL, T20SS & T20SH.

FRONT WHEEL T20SS AND T20SH

								T20SS	T20SH
1	W1349	FRONT WHEEL COMPLETE	1	1
2	W1285	RIM, SPOKES AND HUB ASSEMBLY	1	1
3	W1002	Front wheel rim, WM1-19	1	1
4	W1289	Spoke (10 12G x 8½ in. 90°) c/w nipple	20	20
5	W1205	Spoke (10/12G x 6⅞ in. 100°) c/w nipple	10	10
6	W1206	Spoke (10/12G x 6⅞ in. 80°) c/w nipple	10	10
7	W965	Nipple	40	40
8	W1286	Hub and brake drum	1	1
9	W1350	Wheel spindle	1	1
10	T530	Left bearing	1	1
11	W966	Dust cover	1	1
12	T532	Circlip	1	1
13	H826	Right bearing	1	1
14	W968	Retaining ring	1	1
15	W1353	Brake anchor plate	1	1
16	W977	BRAKE SHOE C/W LINING	2	2
17	W978	Brake lining	2	2
18	W979	Brass rivet	12	12
19	W200	Shoe return spring	1	1
20	W1128	Brake cam	1	1
21	W1133	Brake cam lever	1	1
22	S25-71	Plain washer	1	1
23	T224	Nut	1	1
24	W1093	Anchor plate nut	1	1
25	W1351	Spindle sleeve	2	2

N.B.- TR20 model uses the following items:-

								TR20
1	W1450	FRONT WHEEL COMPLETE	1
2	W1448	RIM, SPOKES AND HUB ASSEMBLY	1
3	W1449	Front wheel rim WM1-21	1
4	W354	Spoke (10G x 9⅜ in. x 78°) c/w nipple	20
5 or 6	W1465	Spoke (10G x 7⅝ in. x 90°) c/w nipple	20
7	S79-2	Nipple	40
10	W1431	Left bearing	1
16	W1457	BRAKE SHOE C/W LINING	2
17	W1458	Brake lining	2

WHEEL COMPLETE REF. N° 1
RIM, SPOKES & HUB REF. N° 2

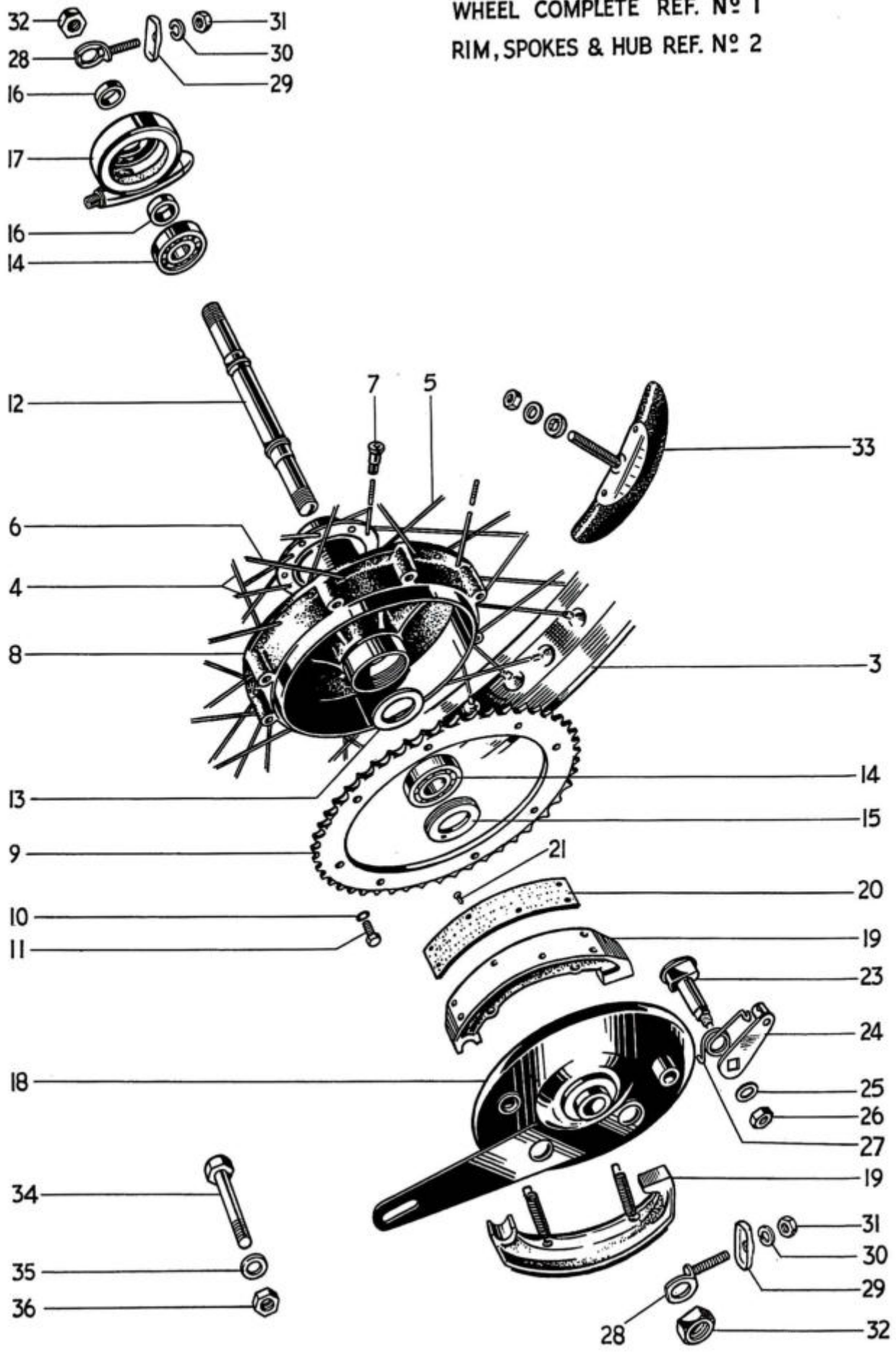

Fig. 13. REAR WHEEL

REAR WHEEL

								T20	T20SS	T20SH
1	W1384	REAR WHEEL COMPLETE	1	-	-
1	W1418	REAR WHEEL COMPLETE	-	-	1
1	W1446	REAR WHEEL COMPLETE	-	1	-
2	W1385	RIM, SPOKES AND HUB ASSEMBLY	1	-	-
2	W1368	RIM, SPOKES AND HUB ASSEMBLY	-	-	1
2	W1447	RIM, SPOKES AND HUB ASSEMBLY	-	1	-
3	W1397	Rear wheel rim WM 2 - 17	1	-	-
3	W1296	Rear wheel rim WM 2 - 18	-	-	1
3	W1007	Rear wheel rim WM 3 - 18	-	1	-
4	W1381	Spoke (10/12G × 7 $\frac{7}{16}$ in. 90°) c/w nipple	20	-	-
4	W1293	Spoke (10/12G × 7 $\frac{15}{16}$ in. 90°) c/w nipple	-	-	20
4	W1465	Spoke (10G × 7 $\frac{13}{16}$ in. 90°) c/w nipple	-	20	-
5	W1382	Spoke (10/12G × 5 $\frac{7}{8}$ in. 100°) c/w nipple	10	-	-
5	W1294	Spoke (10/12G × 6 $\frac{3}{8}$ in. 100°) c/w nipple	-	-	10
5	W934	Spoke (10G × 6 $\frac{3}{8}$ in. 94°) c/w nipple	-	10	-
6	W1383	Spoke (10/12G × 5 $\frac{7}{8}$ in. 80°) c/w nipple	10	-	-
6	W1295	Spoke (10/12G × 6 $\frac{3}{8}$ in. 80°) c/w nipple	-	-	10
6	W933	Spoke (10G × 6 $\frac{3}{8}$ in. 83°) c/w nipple	-	10	-
7	W965	Nipple	40	-	40
7	S79-2	Nipple	-	40	-
8	W1362	Hub and brake drum	1	1	1
9	W1320	*Sprocket (46T)	1	-	-
9	W984	*Sprocket (48T)	-	1	1
10	W1122	Spring washer	8	8	8
11	W1322	Bolt ($\frac{5}{8}$ in. U.H.)	8	8	8
12	W989	Spindle	1	1	1
13	W987	Backing ring...	1	1	1
14	†H826	Bearing	2	2	2
15	W988	Retaining ring	1	1	1
16	W1223	Distance piece	2	2	2
17	D175	Speedometer gearbox (TS20 uses W1454 spacer)	-	1	1
17	D489	Speedometer gearbox	1	-	-
18	W1365	Brake anchor plate	1	1	1

* For alternative sprockets see Page 11.

(continued on Page 43)

WHEEL COMPLETE REF. N° 1
RIM, SPOKES & HUB REF. N° 2

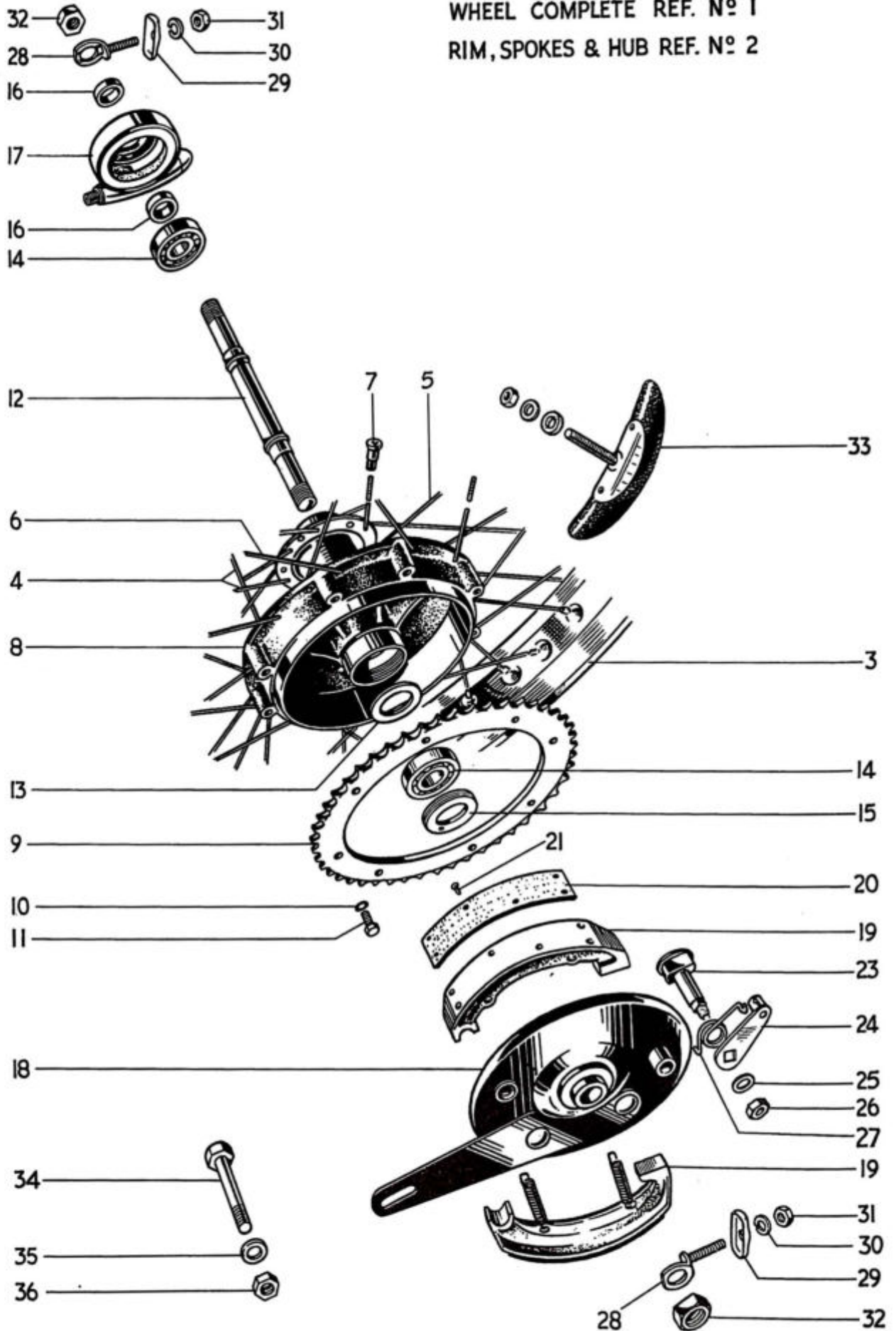

Fig. 13. REAR WHEEL

Ref. No. Part No.

DESCRIPTION

REAR WHEEL—(continued)

									T20	T20SS	T20SH
19	†W977	BRAKE SHOE C/W LINING	2	2	2
20	†W978	Brake lining	2	2	2
21	W979	Brass rivet	12	12	12
22	W200	Shoe return spring	2	2	2
23	W1128	Brake cam	1	1	1
24	W1221	Brake cam lever	1	1	1
25	S25-71	Plain washer	1	1	1
26	T224	Nut	1	1	1
27	W592	Return spring	—	1	—
28	W1224	Chain adjuster	2	2	2
29	W1227	End plate	2	2	2
30	S26-2	Spring washer	2	2	2
31	F879	Nut	2	2	2
32	W1000	Nut	2	2	2
33	D106	Tyre security bolt	—	—	1
33	WM-3	Tyre security bolt	—	2	—
34	H211	Bolt ($\frac{1}{8}$ in. U.H.)	1	1	1
35	F2184	Plain washer	1	1	1
36	F3955	Self-locking nut	1	1	1

† TR20 uses the following:—

- 14 W1432 Right bearing
- 19 W1457 BRAKE SHOE C/W LINING
- 20 W1458 Brake lining

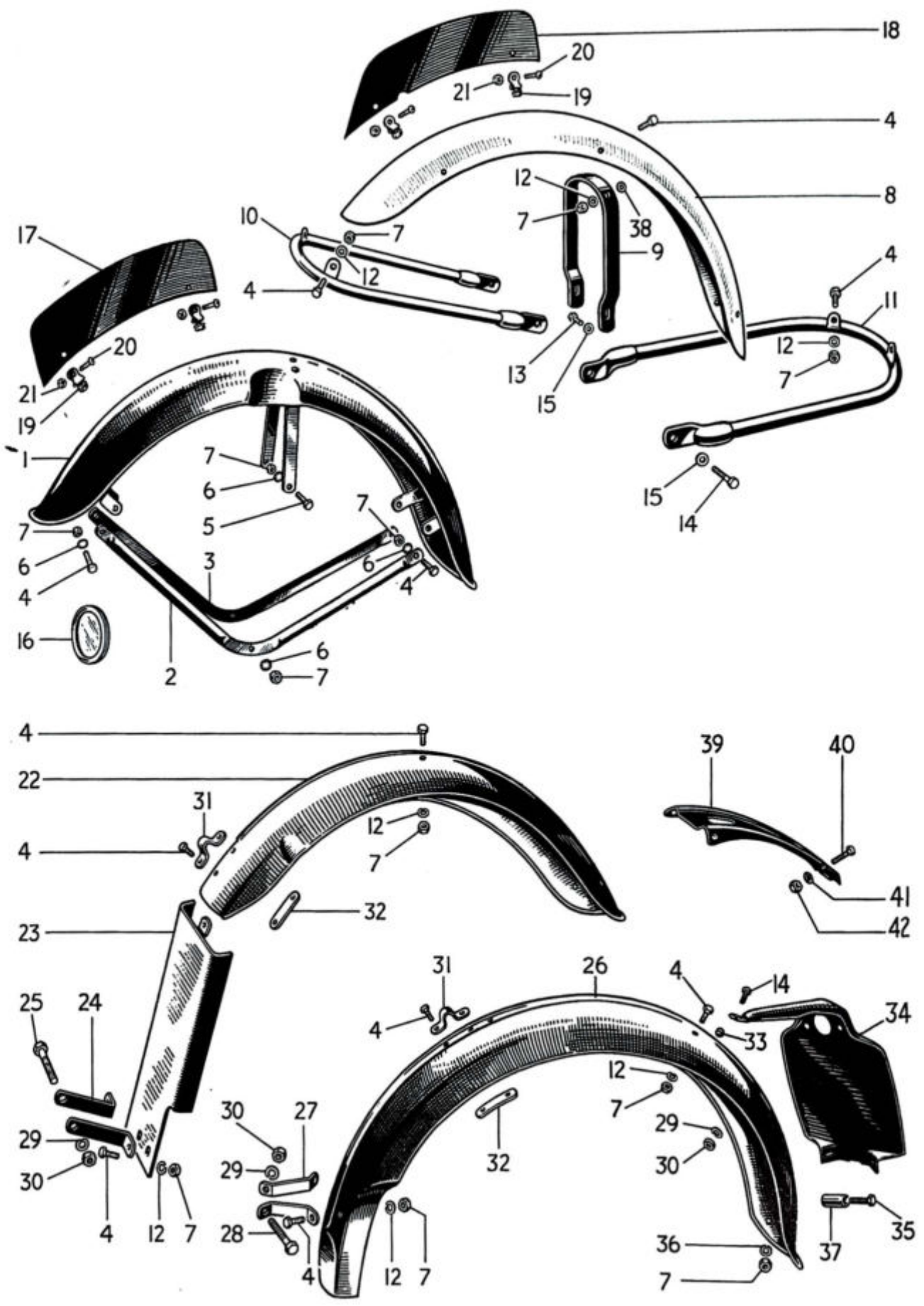

Fig. 14. MUDGUARDS AND NUMBER PLATES

MUDGUARDS AND NUMBER PLATES

									T20	T20SS	T20SH
1	H929	Front mudguard (Without number plate holes H1546)	1	-	-
2	H871	Left stay	1	-	-
3	H872	Right stay	1	-	-
4	DS57	Bolt ($\frac{7}{16}$ in. U.H.)	10	12	12
5	GS218	Bolt ($\frac{9}{16}$ in. U.H.)	2	-	-
6	E1612	Serrated washer	8	-	-
7	F879	Nut	14	12	12
8	H1428	Mudguard blade (Polished)	-	A	-
8	H1269	Mudguard blade (Without number plate holes H1551)	-	A	1
9	H1270	Bridge (H1426 with 21 in. wheel)	-	1	1
10	H1271	Front stay (not required with 21 in. wheel)	-	1	1
11	H1273	Lower stay	-	1	1
12	S25-1	Plain washer	6	12	12
13	F2335	Bolt ($\frac{11}{16}$ in. U.H.) (H590 with H1426 Bridge)	-	2	2
14	F929	Bolt ($\frac{1}{2}$ in. U.H.)	1	3	3
15	S25-3	Plain washer	-	4	4
16	D261	Licence holder	1	1	1
17	H874	Number plate	1	-	-
18	F2996	Number plate	-	1	1
19	H741	Clip assembly	2	2	2
20	H687	Screw ($\frac{3}{8}$ in. U.H.)	2	2	2
21	H745	Nut	2	2	2
22	F5914	Mudguard	1	-	-
23	F4499	Mudshield...	1	-	-
24	F4502	Stay	2	-	-
25	F4531	Bolt ($1\frac{1}{8}$ in. U.H.)	1	-	-
26	F5916	Mudguard	-	1	1
26	F5167	Mudguard (polished)	-	A	-
27	F4606	Stay	-	2	2
27	F5640	Stay (For F5167 blade)	-	A	-
28	DS55	Bolt ($1\frac{1}{8}$ in. U.H.)	-	1	1
29	S26-3	Spring washer	2	2	2
30	S1-51	Nut	2	2	2
31	PF204	Clip	1	1	1
32	F444	Backing plate	1	1	1
33	E3203	Grommet	2	2	2
34	F3363	Number plate	1	1	1
35	F1149	Bolt ($\frac{7}{8}$ in. U.H.)	2	2	2
36	S26-2	Spring washer	2	2	2
37	F4374	Distance piece	2	2	2
38	WE170	Fibre washer	-	2	2
39	F5168	Backing plate (For F5167 mudguard)	-	A	-
40	F4771	Bolt ($\frac{1}{2}$ in. U.H.)	-	A	-
41	GS299	Serrated washer	-	A	-
42	F3799	Nut	-	A	-

TWINSEAT ASSY. REF. N° 1

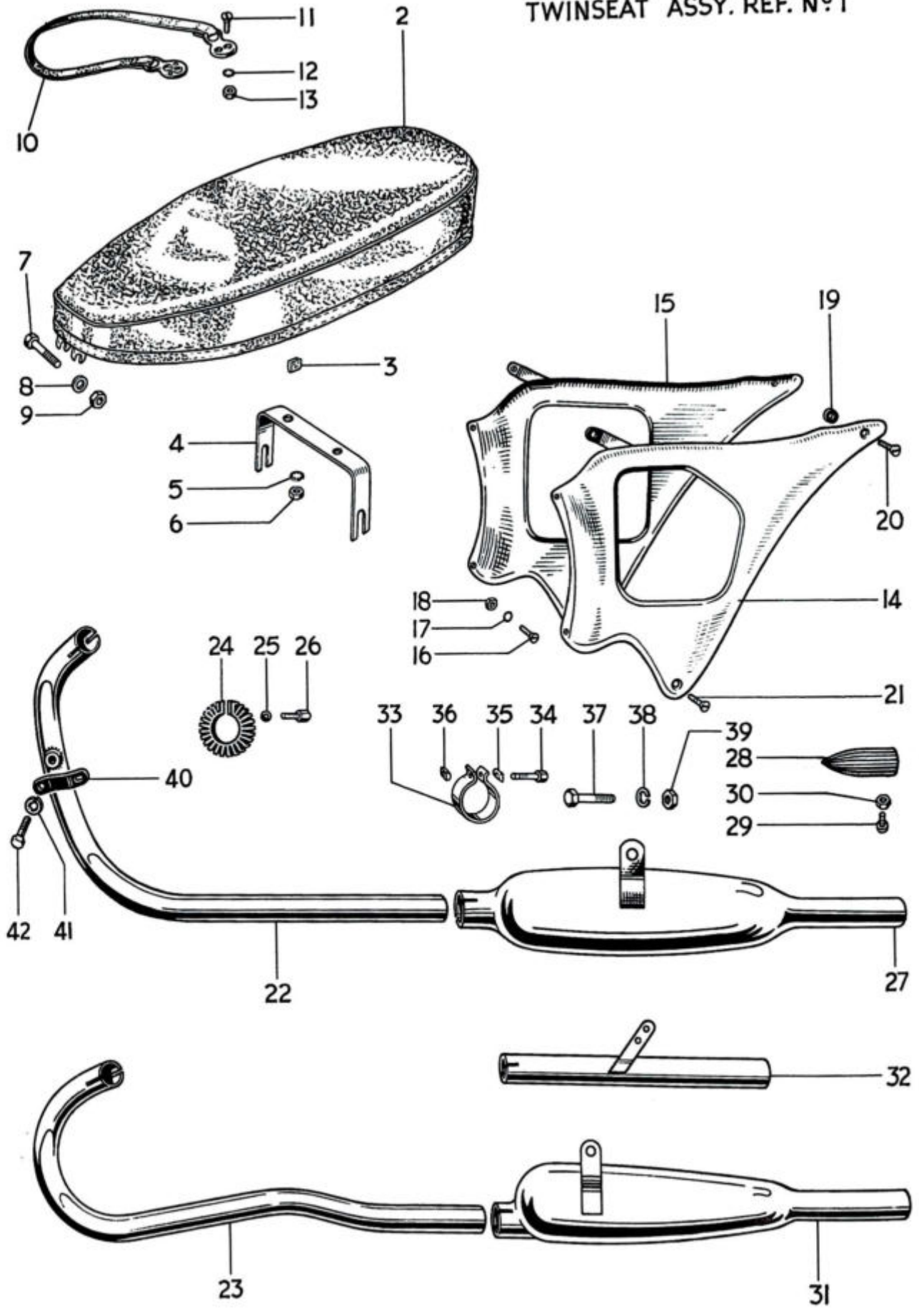

Fig. 15. TWINSEAT, REAR PANELS AND EXHAUST SYSTEM

TWINSEAT, REAR PANELS AND EXHAUST SYSTEM

										T20	T20SS	T20SH
1	F4516	TWINSEAT COMPLETE	1	-	-
1	†F4272	TWINSEAT COMPLETE	-	1	1
2	*F4104	Cover c/w Clips	1	1	1
3	F4475	Clip	as required		
4	F4105	Rear bracket	1	-	-
4	F4261	Rear bracket	-	1	1
5	E1612	Serrated washer	2	2	2
6	F879	Nut	2	2	2
7	E3181	Bolt (2¼ in. U.H.)	1	-	-
7	E667A	Bolt (1½ in. U.H.)	-	1	1
8	S25-3	Plain washer	1	1	1
9	E1310	Nut	1	1	1
10	F4361	Safety strap	A	A	A
11	F4129	Screw (½ in. U.H.)	4	4	4
12	GS299	Serrated washer	4	4	4
13	H745	Nut	4	4	4
14	F4503	Left panel	1	-	-
15	F4505	Right panel	1	-	-
16	H687	Screw (¾ in. U.H.)	2	-	-
17	E2351	Serrated washer	2	-	-
18	F3799	Nut	2	-	-
19	F4512	Rubber washer	2	-	-
20	F4483	Self-tapping screw	2	-	-
21	F4511	Screw (⅝ in. U.H.)	2	-	-
22	E4738	Exhaust pipe	1	-	1
23	E4930	Exhaust pipe (upswept)	-	-	A
23	E4497	Exhaust pipe (upswept)	-	1	-
24	E3259	Clip	1	1	1
24	E4932	Clip (chrome)	A	A	A
25	S25-13	Plain washer	1	1	1
26	E3260	Bolt (⅞ in. U.H.)	1	1	1
27	E3928	Silencer	1	1	1
28	E4076	Silencer mute	1	A	A
29	H689	Screw (¼ in. U.H.)	1	A	A
30	H691	Nut	1	A	A
31	E3840	Silencer (upswept)	-	-	A
31	E4496	Silencer (upswept)	-	1	-
32	**E3967	Extension pipe	A	-	A
33	E3269	Clip	1	1	1
34	TE164E	Bolt	1	1	1
35	TE164D	"D" washer	1	1	1
36	TE164C	"D" nut	1	1	1
37	F1031	Bolt (½ in. U.H.), silencer hanger	-	A	A
38	S26-1	Spring washer	-	A	A
39	P0172A	Nut	-	A	A
40	E4737	Bracket	1	1	1
41	S26-3	Spring washer	1	1	1
42	F929	Bolt	1	1	1

† F5126 Trials seat used on T20SC, TS20 and TR20 models

* F5128 Trials seat cover c/w clips used on T20SC, TS20 and TR20 models

** E4498 Extension pipe used on TS20 models

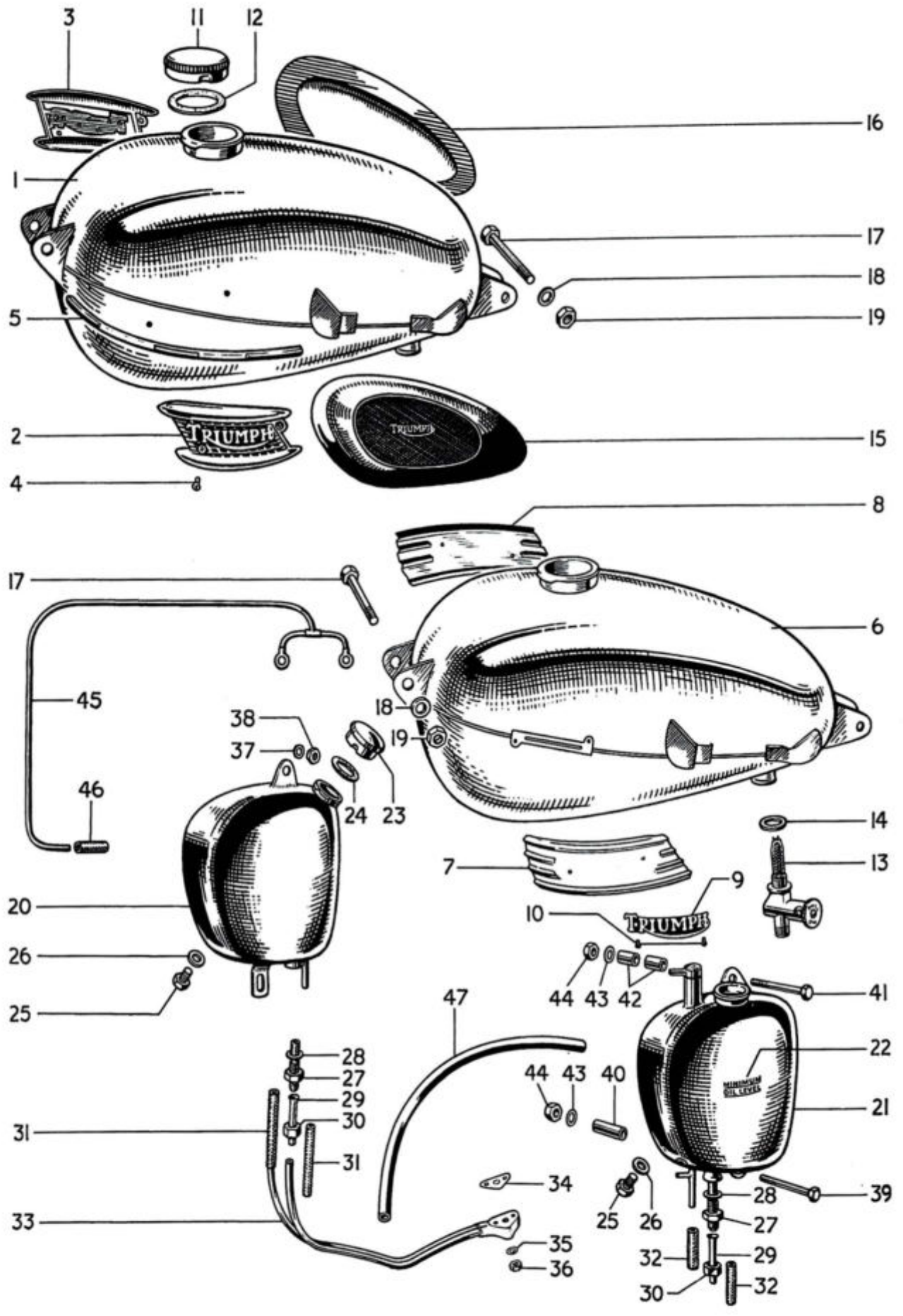

Fig. 16. PETROL AND OIL TANKS

Ref. No.	Part No.	DESCRIPTION	QUANTITY
PETROL AND OIL TANKS			
			T20 T20SS T20SH
1	F4496	Petrol tank (3 gallons)	1 - 1
2	F4570	Left styling unit	1 - 1
3	F4571	Right styling unit	1 - 1
4	F4468	Screw ($\frac{9}{16}$ in. U.H.)	4 - 4
5	F5100	Styling strip	2 - 2
6	F3505	Petrol tank (2½ gallons)	- 1 -
7	F3494	Left styling band	- 1 -
8	F3495	Right styling band	- 1 -
9	F3496	Nameplate	- 2 -
10	F3497	Screw ($\frac{3}{8}$ in. U.H.)	- 4 -
11	F3220	FILLER CAP	1 1 1
12	F4048	Joint washer	1 1 1
13	F4908	Petrol tap	1 1 1
14	E697	Fibre washer	1 1 1
15	F1606	Left knee grip	1 1 1
16	F1605	Right knee grip	1 1 1
17	F3498	Bolt ($2\frac{5}{8}$ in. U.H.)	2 2 2
18	S25-3	Plain washer	2 2 2
19	S1-51	Nut	2 2 2
20	F5491	OIL TANK	1 - -
21	F4572	OIL TANK	- 1 -
21	F5546	OIL TANK	- - 1
22	A3	Transfer (Minimum oil level)	- 1 1
23	F5155	FILLER CAP	1 - -
23	F3216	FILLER CAP	1 1 1
24	F4047	Joint washer	1 1 1
25	F5343	Drain plug	1 1 1
26	PT104B	Fibre washer	1 1 1
27	F3876	Filter	1 1 1
28	F1511	Fibre washer	1 1 1
29	F3503	Upper feed pipe	1 1 1
30	F3504	Union nut	1 1 1
31	F4530	Rubber connector	2 - -
32	F3077	Rubber connector	- 2 -
32	E4524	Rubber connector	- - 2
33	E3270	Oil pipes and junction block	1 1 -
33	E4519	Oil pipes and junction block	- - 1
34	E3274	Joint washer	1 1 1
35	S25-13	Plain washer	1 1 1
36	F879	Nut	1 1 1
37	S25-2	Plain washer	1 - -
38	S1-52	Nut	1 - -
39	F2596	Bolt ($1\frac{7}{8}$ in. U.H.)	- 1 1
40	F3477	Distance piece	- 1 1
41	F3468	Bolt ($2\frac{1}{8}$ in. U.H.)	- - 1
41	†F3805	Bolt ($1\frac{5}{16}$ in. U.H.)	- 1 -
42	F3476	Distance piece	- 2 2
43	S25-3	Plain washer	- 2 2
44	S1-51	Nut	- 2 2
45	E3244	Rocker oil feed pipe	1 1 1
46	E3383	Rubber connector	1 1 1
47	T1203	Flexible vent pipe	1 1 1
48	F3098	Cable clip	2 2 2

† TR20 uses F3468 Bolt

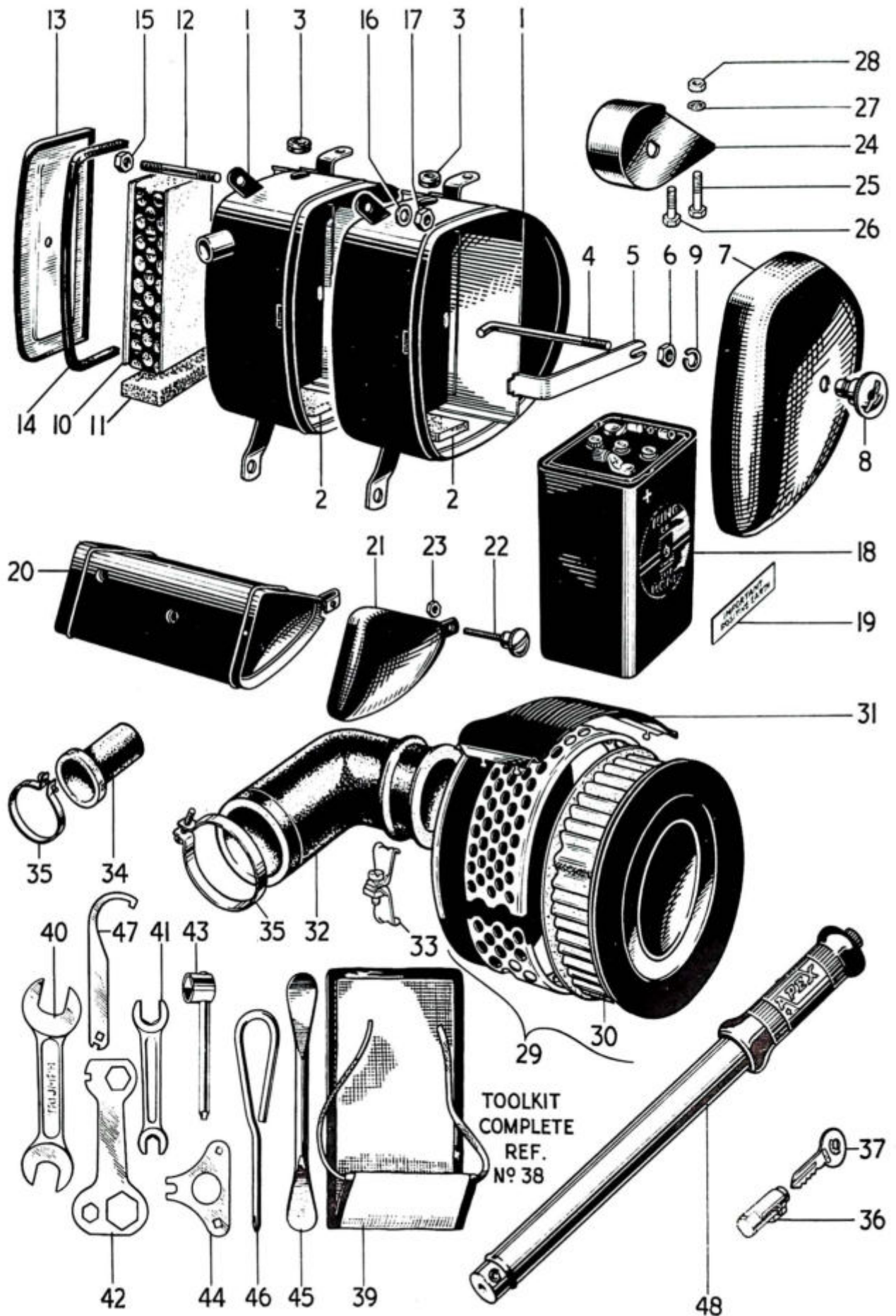
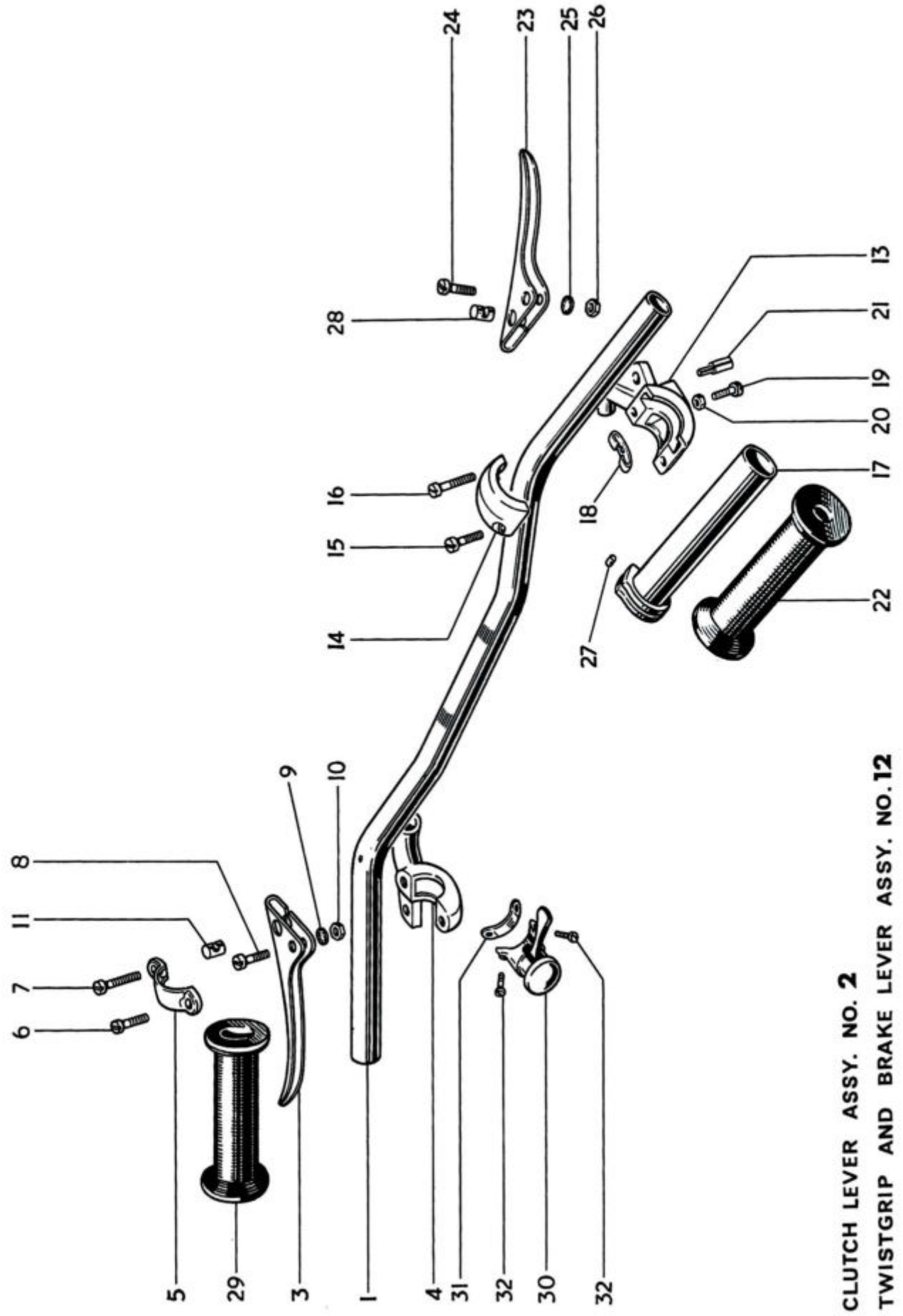

Fig. 17. BATTERY CASE, TOOLBOX AND AIR FILTER

BATTERY CASE, TOOLBOX AND AIR FILTER

									T20	T20SS	T20SH
1	F4515	BATTERY CASE AND TOOLBOX	1	-	-
1	F5139	BATTERY CASE, AIR FILTER AND TOOL BOX	-	-	1
2	F3470	Rubber pad	2	-	2
3	199002	Grommet	1	-	1
4	F3472	Hook bolt	1	-	1
5	F3473	Strap	1	-	1
6	F879	Nut	1	-	1
7	F3493	Lid c/w knob	1	-	1
8	F3474	Knob	1	-	1
9	F3475	Circlip	1	-	1
10	F5137	Air filter element	-	-	1
11	F5140	Rubber pad	-	-	1
12	F3656	Stud (1½ in. O.A.)	-	-	1
13	F5141	Lid	-	-	1
14	H251	Beading	-	-	1
15	H745	Nut	-	-	1
16	S25-2	Plain washer	1	-	-
17	S1-52	Nut	1	-	-
18	408200	Battery PUZ5E/11	1	-	1
19	A52	Transfer "Positive earth"	1	-	1
20	F4877	TOOLBOX	-	1	-
21	F4882	Toolbox lid	-	1	-
22	F4885	Fastener screw	-	1	-
23	F4717	Self locking nut	-	1	-
24	F5143	Switch bracket	-	-	2
25	F1369	Bolt (⅝ in. U.H.)	-	-	1
26	DS57	Bolt (⅞ in. U.H.)	-	-	3
27	E1612	Serrated washer	-	-	4
28	F879	Nut	-	-	4
29	†F5965	AIR FILTER	-	1	-
30	F5694	Element and back plate assembly (paper element)	-	1	-
31	F4964	Water deflector	-	1	-
32	F5038	Rubber connector	-	1	-
33	F4810	Clip	-	1	-
34	F5142	Rubber connector	-	-	1
35	F3859	Clip	-	1	1
36	D402/3	FRAME LOCK C/W 2 KEYS	1	1	1
37	D403	Key (state number)	1	1	1
38	D290	TOOLKIT	1	-	1
38	D533	TOOLKIT	-	1	-
39	D291	Toolbag	1	1	1
40	D299	Open spanner, ⅜ in. x ⅞ in. Whit.	1	1	1
41	D292	Open spanner, ⅜ in. x ⅞ in. x ¼ in. x ⅝ in. Whit.	1	1	1
42	D293	Combination spanner, ⅜ in. x ⅝ in. x ½ in. Whit.	1	1	1
43	D294	Screwdriver and ¼ in. Whit. spanner	1	1	1
44	DA70	Clutch key	1	1	1
45	NA14A	Tyre lever	1	1	1
46	D335	Phillips No. 2 screwdriver	1	1	1
47	D362	"C" spanner	-	1	-
48	D296	Tyre inflator	1	-	1

† TR20 uses F4550 air cleaner, E4214 connector and E4215 carburettor adaptor



**CLUTCH LEVER ASSY. NO. 2
TWISTGRIP AND BRAKE LEVER ASSY. NO. 12**

Fig. 18. HANDLEBARS AND CONTROL LEVERS. T20

HANDLEBARS AND CONTROL LEVERS T20

											T20	
1	†H1672	Handlebar bend	1
2	†18/1058	CLUTCH LEVER ASSEMBLY	1
3	18/1051	Clutch lever	1
4	18/1059	Clutch lever bracket	1
5	12/595	Clamp	1
6	11/013	Clamp screw	1
7	11/014	Clamp screw	1
8	18/087	Fulcrum screw	1
9	70/016	Spring washer	1
10	18/717	Nut	1
11	18/615	Barrel nipple (D.506)	1
12	†368/20	COMBINED TWISTGRIP AND FRONT BRAKE LEVER ASSEMBLY	1
13	368/013	Body top half	1
14	368/014	Body bottom half	1
15	11/013	Clamp screw	1
16	11/014	Clamp screw	1
17	366/004	Rotor	1
18	366/007	Friction spring	1
19	16/009	Friction spring screw	1
20	16/010	Lock nut	1
21	366/006	Cable stop	1
22	16/070	Handlebar grip	1
23	368/015	Front brake lever	1
24	18/087	Fulcrum screw	1
25	70/016	Spring washer	1
26	18/717	Nut	1
27	366/005	Barrel nipple (D.411) for throttle cable	1
28	18/615	Barrel nipple (D.506) for brake cable	1
29	16/069	Handlebar grip	1
30	31563	Dipper switch and horn push (25SA)	1
31	380/459	Backing rubber	1
32	†H713	Screw ($\frac{3}{8}$ in. U.H.)	2

† Note. U.S. T20 model uses the following items:-

1	H1519	Handlebar bend (see page 55 for control cables)
12	18/796	FRONT BRAKE LEVER ASSEMBLY
2	18/996	CLUTCH LEVER ASSEMBLY
12	366/2	TWISTGRIP
32	H689	Screws ($\frac{1}{4}$ in. U.H.) for combined dipper switch and horn push

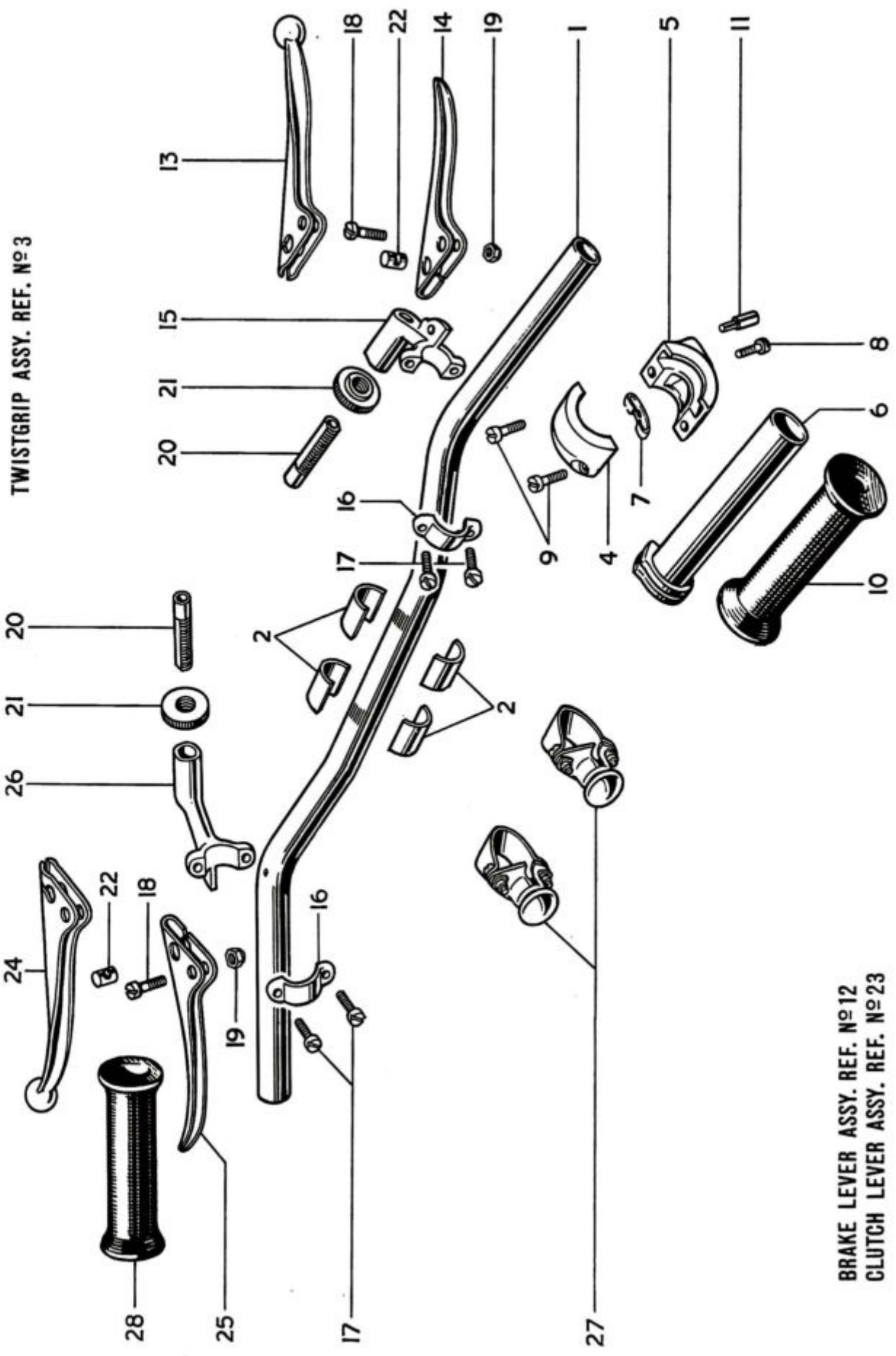

Fig. 19. HANDLEBARS AND CONTROL LEVERS. T20SS AND T20SH .

Ref. No.	Part No.	DESCRIPTION	QUANTITY	
			T20SS	T20SH
1	†H1519	Handlebar bend	1	-
1	H527	Handlebar bend	-	1
2	H1425	Packing piece	4	4
3	366/2	TWISTGRIP	1	1
4	366/001	Body top half	1	1
5	366/002	Body bottom half	1	1
6	366/004	Rotor	1	1
7	366/007	Friction spring	1	1
8	366/008	Friction spring screw	1	1
9	376/079	Screw	2	2
10	16/070	Handlebar grip	1	1
11	366/006	Cable stop	1	1
12	18/935	FRONT BRAKE LEVER ASSEMBLY (Ball end)...	1	-
12	18/995	FRONT BRAKE LEVER ASSEMBLY	-	1
13	18/754	Brake lever (Ball end)	1	-
14	18/535	Brake lever	-	1
15	18/912	Brake lever bracket	1	1
16	12/040	Clamp	1	1
17	11/014	Screw	2	2
18	18/087	Fulcrum screw	1	1
19	18/053	Self-locking nut	1	1
20	18/838	Cable adjuster	1	1
21	18/839	Thumb nut	1	1
22	18/880	Barrel nipple	1	1
23	18/942	CLUTCH LEVER ASSEMBLY (Ball end)	1	-
23	18/557	CLUTCH LEVER ASSEMBLY	-	1
24	18/752	Clutch lever (Ball end)...	1	-
25	18/528	Clutch lever	-	1
15	18/912	Clutch lever bracket	1	-
26	18/234	Clutch lever bracket	-	1
16	12/040	Clamp	1	1
17	11/014	Screw	2	2
18	18/087	Fulcrum screw	1	1
19	18/053	Self-locking nut	1	1
20	18/838	Cable adjuster	1	-
21	18/839	Thumb nut	1	-
22	18/880	Barrel nipple	1	-
27	76204	Horn push or cut-out button, type 4A	2	1
28	16/069	Handlebar grip	1	1

† H1436 Handlebar bend for TR20

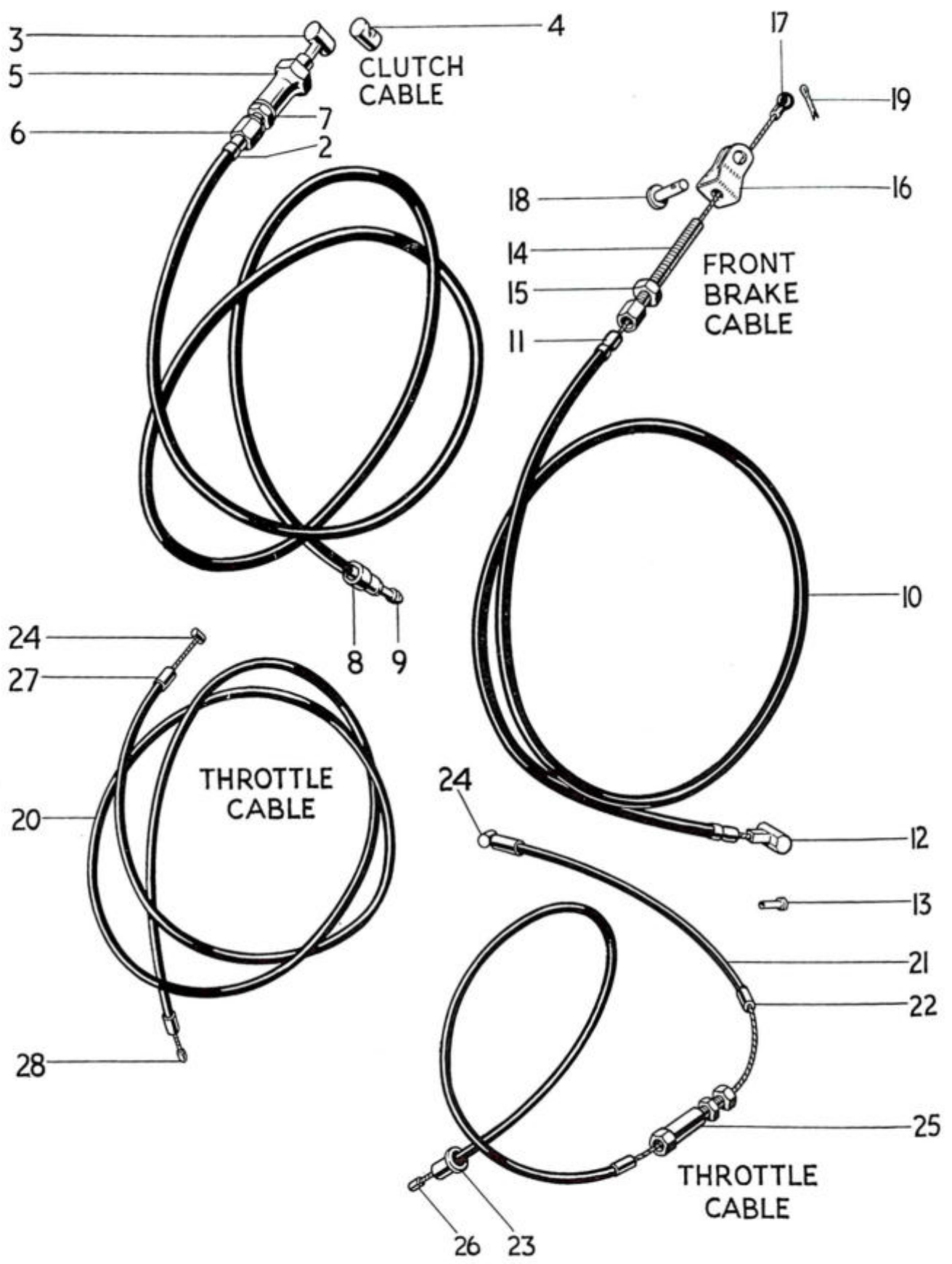

Fig. 20. CONTROL CABLES

CONTROL CABLES

										T20	T20SS	T20SH
1	D504	CLUTCH CABLE	1	-	-
1	†D332	CLUTCH CABLE	A	-	1
1	†D488	CLUTCH CABLE	-	1	A
2	D103	Ferrule	2	2	2
3	D506	Nipple (H/Bar end)	1	-	-
4	D368	Nipple (H/Bar end)	-	1	-
4	D81	Nipple (H/Bar end)	-	-	1
5	D288	Abutment	1	-	1
6	D333	Abutment	1	1	1
7	D334	Nipple	1	1	1
8	D319	Cable adjuster	1	-	1
9	D268	Nut	1	-	1
10	D505	FRONT BRAKE CABLE	1	-	-
10	†D503	FRONT BRAKE CABLE	A	-	-
10	D429	FRONT BRAKE CABLE	-	-	1
10	†D497	FRONT BRAKE CABLE	-	1	A
11	D103	Ferrule	2	2	2
12	D506	Nipple (H/Bar end)	1	-	-
13	D368	Nipple (H/Bar end)	-	1	1
14	D279	Cable adjuster	1	-	-
15	F879	Nut	1	-	-
16	D280	Clevis	1	1	1
17	DS73	Nipple	1	1	1
18	D281	Clevis pin	1	1	1
19	$\frac{1}{8}$ in. x $\frac{3}{8}$ in.	Split pin	1	1	1
20	D453	THROTTLE CABLE	1	-	-
21	D420	THROTTLE CABLE	-	1	1
22	12/083	Ferrule	-	3	3
23	6/132A	Ferrule	-	1	1
24	D411	Nipple (H/Bar end)	1	1	1
25	D104	Adjuster	-	1	1
26	NS191	Nipple	-	1	1
27	18/145	Ferrule	1	-	-
28	D407	Nipple	1	-	-

† Use alternative shewn with "overseas" type handlebars H1519

CARBURETTER COMPLETE
REF. No. I

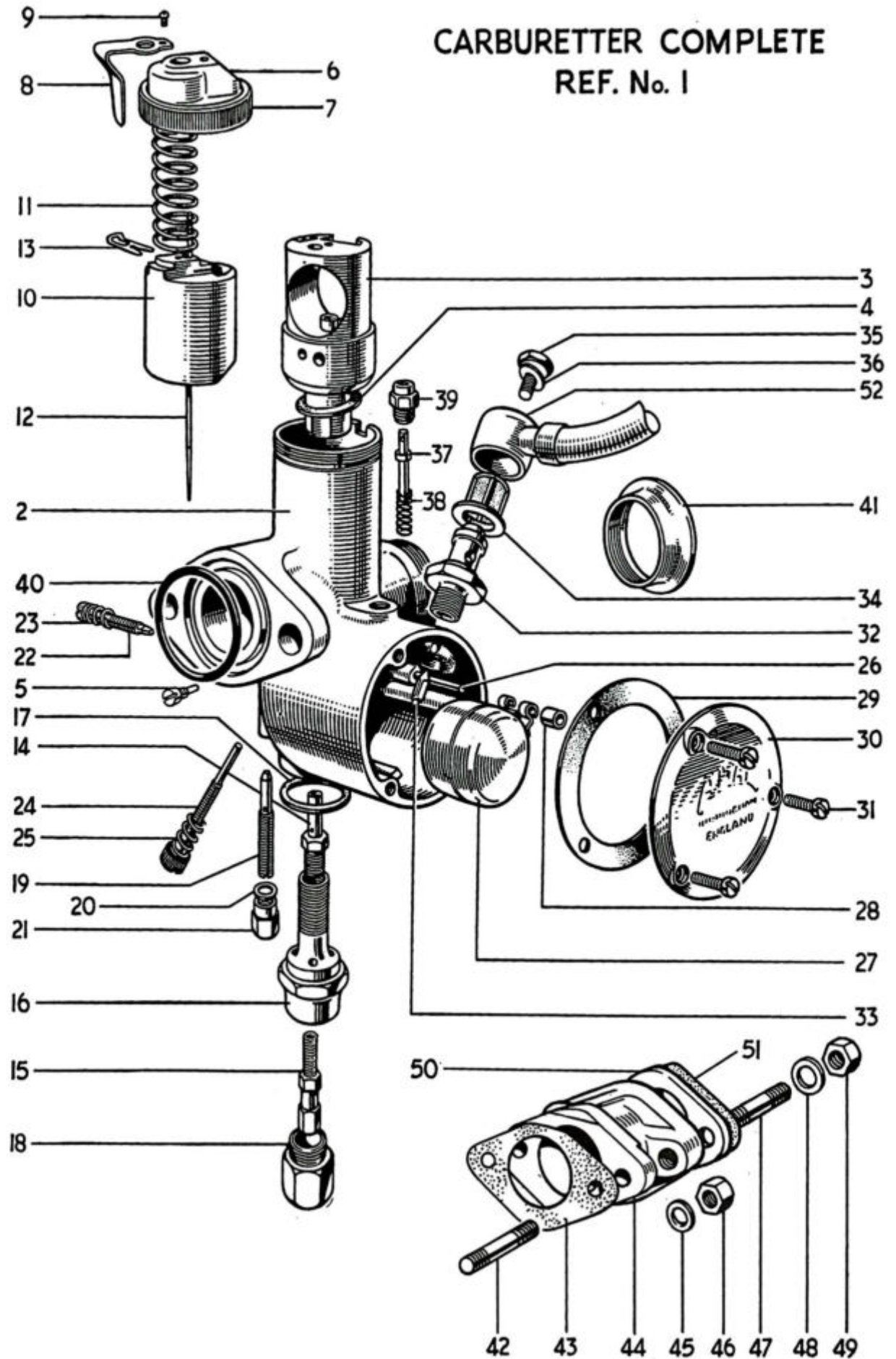

Fig. 21. AMAL CARBURETTER, TYPE 376

Ref. No.	Part No.	DESCRIPTION	QUANTITY										
			T20SS T20SH										
		AMAL CARBURETTER, TYPE 376											
1	376/272	CARBURETTER COMPLETE	1	1
2	376/001	Mixing chamber	1	1
3	376/055	Jet block	1	1
4	376/067	Joint washer	1	1
5	376/070	Peg screw	1	1
6	376/155	Mixing chamber top	1	1
7	376/065	Cap ring	1	1
8	29/308	Spring	1	1
9	4/241	Screw	1	1
10	376/060	Throttle valve (No. 3 Cutaway)	1	1
11	376/061	Spring	1	1
12	376/063	Needle (Type C)	1	1
13	4/230	Clip	1	1
14	376/072	Needle jet ('106)	1	1
15	376/100	Main jet (140)	1	1
16	376/073	Jet holder	1	1
17	376/074	Fibre washer	1	1
18	376/075	Cover nut	1	1
19	376/076	Pilot jet (20)	1	1
20	116/162	Fibre washer	1	1
21	376/095	Cover nut	1	1
22	332/017	Air adjusting screw	1	1
23	4/148	Spring	1	1
24	376/068	Throttle stop screw	1	1
25	376/069	Spring	1	1
26	376/085	Float spindle	1	1
27	376/083	Float	1	1
28	376/094	Bush	1	1
29	376/078	Joint washer	1	1
30	376/077	Cover	1	1
31	376/079	Screw	3	3
32	376/088	Needle seating	1	1
33	376/089	Needle	1	1
34	376/093	Filter	1	1
35	376/091	Bolt	1	1
36	376/092	Fibre washer	1	1
37	376/086	Tickler	1	1
38	376/087	Spring	1	1
39	343/011	Tickler body	1	1
40	244/1048	"O" ring seal	1	1
41	376/066	Air intake tube	A	A
42	E3956	Stud (1 in. O.A.)	2	2
43	E4051	Joint washer	1	1
44	E4213	Adaptor	1	1
45	E2728	Plain washer	2	2
46	W103	Nut	2	2
47	E1553	Stud (1 $\frac{3}{32}$ in. O.A.)	2	2
48	S25-3	Plain washer	2	2
49	S1-51	Nut	2	2
50	E4504	Insulating block	1	1
51	NA43	Joint washer	1	1
52	F4886	Petrol pipe	1	1

**CARBURETTER COMPLETE
REF. N° 1**

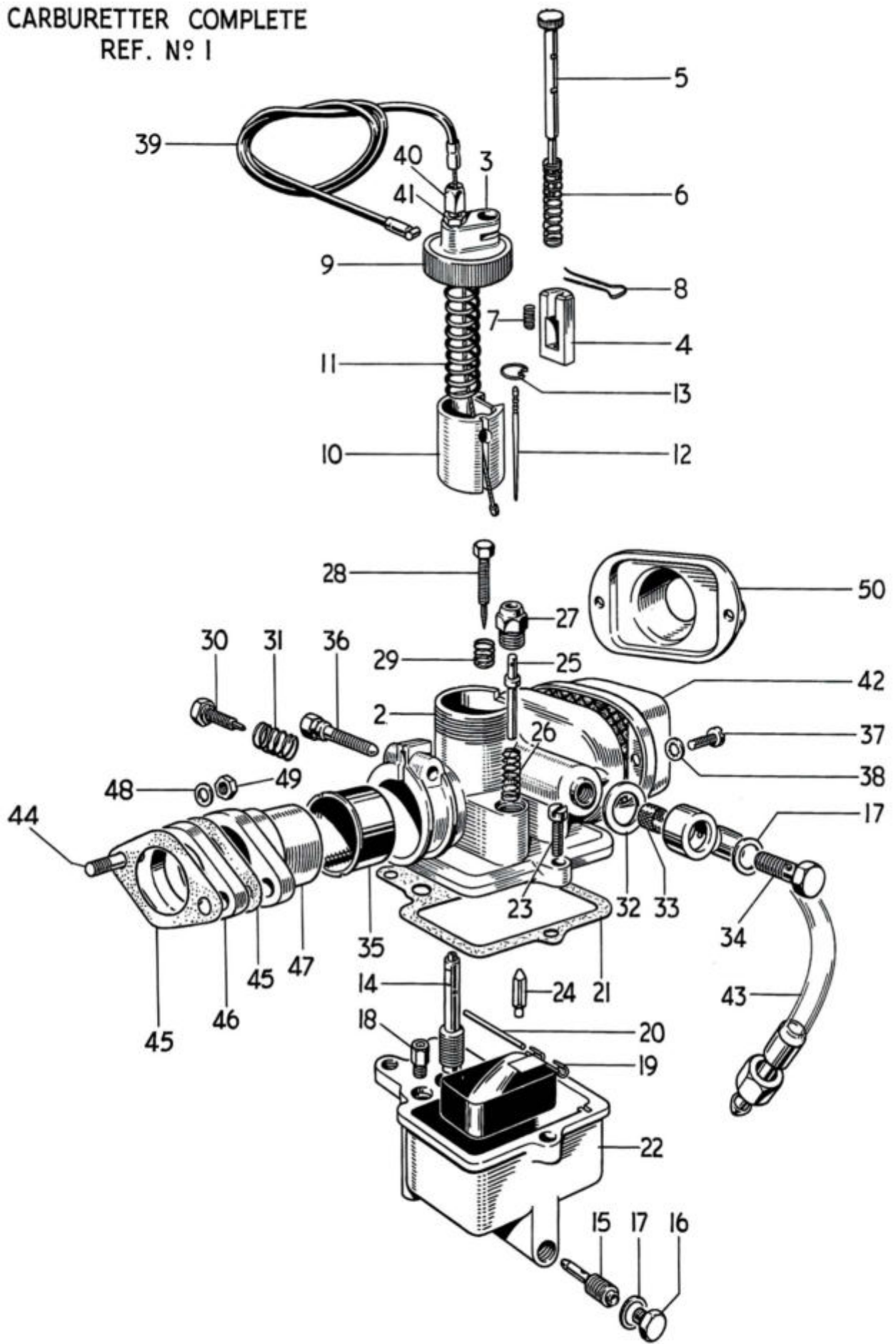

Fig. 22. AMAL CARBURETTER, TYPE 32

Ref. No. Part No.

DESCRIPTION

AMAL CARBURETTER, TYPE 32

T20

Ref. No.	Part No.	DESCRIPTION	QUANTITY
1	†32/1	CARBURETTER C/W THROTTLE CABLE	1
2	32/001	Mixing chamber	—
3	363/094	Mixing chamber top	1
4	32/045	Air valve	1
5	32/048	Air valve rod	1
6	332/009	Return spring	1
7	332/008	Bottom spring	1
8	32/050	Click spring	1
9	332/012	Cap ring	1
10	32/046	Throttle valve (No. 4 Cutaway)	1
11	332/021	Throttle return spring	1
12	32/028	Needle	1
13	363/093	Needle clip	1
14	32/033	Needle jet (103)	1
15	32/023	Main jet (85)	1
16	335/024	Plug screw	1
17	116/124	Fibre washer	2
18	4/042	Pilot jet (15)	1
19	32/041	Float	1
20	32/032	Float spindle	1
21	32/021	Joint washer	1
22	32/020	Float chamber	1
23	32/038	Screw	2
24	376/089	Float needle	1
25	343/012	Tickler	1
26	376/087	Tickler spring	1
27	343/011	Tickler body	1
28	376/119	Pilot air screw	1
29	4/148	Spring	1
30	32/066	Throttle stop screw	1
31	198/012	Spring	1
32	391/026	Fibre washer	1
33	32/026	Filter gauze	1
34	32/027	Banjo bolt	1
35	32/029	Insulating sleeve	1
36	4/048	Clamping screw...	1
37	32/044	Screw	2
38	32/043	Serrated washer	2
39	D453	Throttle cable	1
40	4/035	Cable adjuster	1
41	5/077	Adjuster locknut	1
42	†E3981	Filter	1
43	F5089	Petrol pipe	1
44	E3171	Stud (1 $\frac{5}{32}$ in. O.A.)	2
45	E3250	Joint washer	2
46	E3254	Insulating block	1
47	E3954	Carburetter adaptor	1
48	S25-13	Plain washer	2
49	F879	Nut	2
50	E3955	Air intake adaptor	—

† 32/3 Carburetter fitted to U.S.A export machines has No. 2 throttle valve, 110 main jet and E4060 air filter, (element No. E4063)

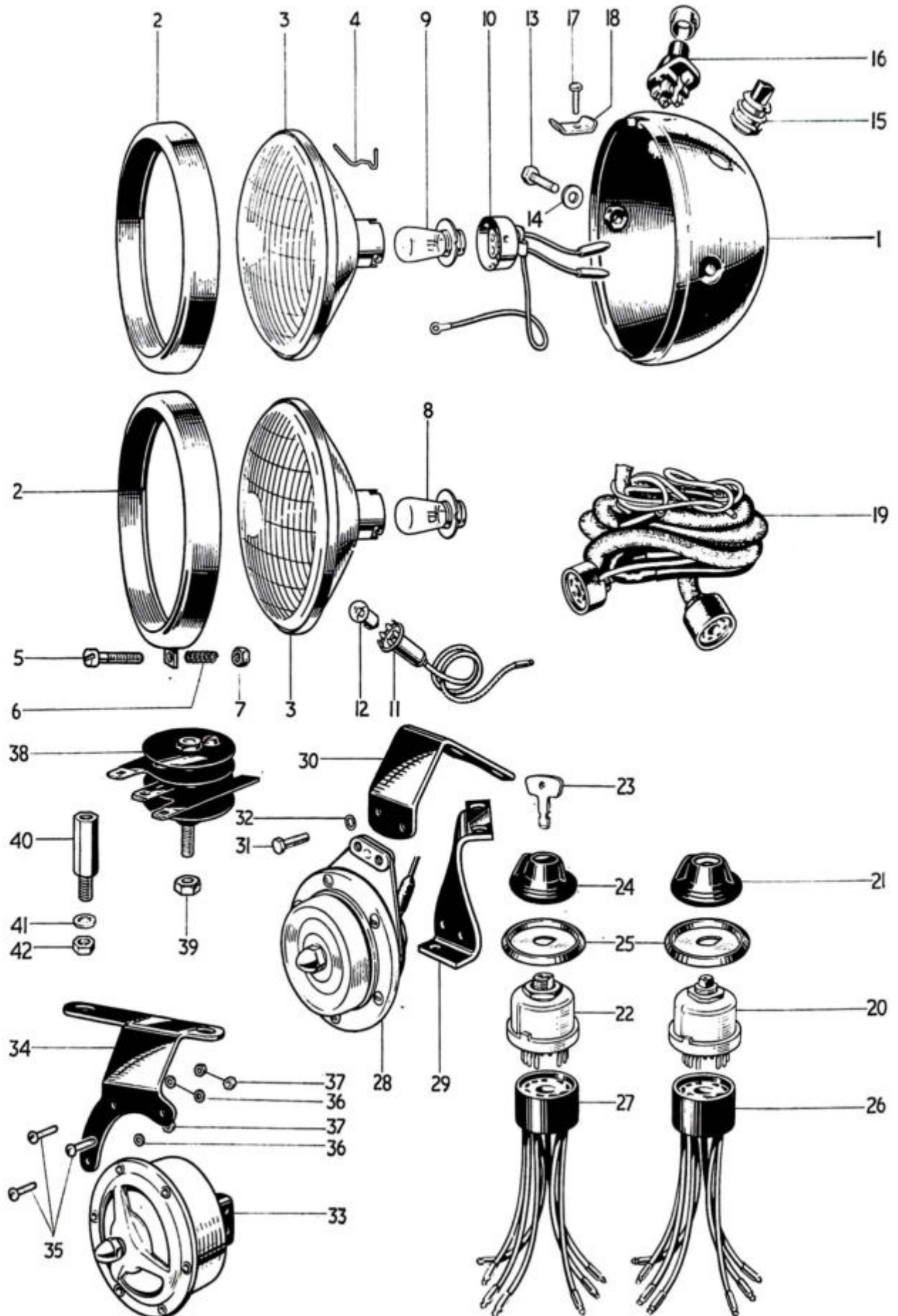

Fig. 23. ELECTRICAL EQUIPMENT, T20, T20SS AND T20SH

ELECTRICAL EQUIPMENT

									T20	T20SS	T20SH
1	†58975	HEADLAMP ASSEMBLY, MCF 575P	1	-	-
1	58395	HEADLAMP ASSEMBLY, MCH 66	-	1	-
1	58935	HEADLAMP ASSEMBLY, MCH 66	-	-	1
2	516723	Rim	1	-	-
2	534343	Rim	-	1	1
3	54520452	Light unit	-	1	-
3	516828	Light unit	1	-	1
4	500291	Fixing wire	5	-	-
4	504665	Fixing wire	-	6	6
5	516710	Screw (H876)	1	-	-
6	552373	Spring (H875)	1	-	-
7	166014	Nut (H745)	1	-	-
8	312	Bulb (30/24W. Pre-focus, Vertical Dip)	1	-	-
9	166	Bulb (24/24W. Pre-focus, Vertical Dip)	-	1	1
10	554602	Adaptor	1	1	1
11	554710	Pilot bulbholder	1	-	1
12	988	Bulb (3W. M.C.C.)	1	-	1
13	112201	Bolt	-	2	2
14	137499	Washer	-	2	2
15	31356	Lighting switch	-	1	-
16	31620	Dip switch	-	1	1
17	144921	Screw	-	1	1
18	534296	Plate	-	1	1
19	54094418	Wiring harness	1	-	-
19	54094433	Wiring harness	-	1	-
19	54933224	Wiring harness	-	-	1
20	34289	Lighting switch, type 88SA	1	-	1
21	54330934	Knob c/w screw	1	-	1
22	34427	IGNITION SWITCH c/w KEY, TYPE 88SA	1	-	1
23	54336176	Ignition key	1	-	1
24	54336178	Ignition switch cover	1	-	1
25	54330485	Switch bezel plate	2	-	-
26	54930007	Replacement harness socket (lighting)	A	-	A
27	54930008	Replacement harness socket (ignition)	A	-	A
28	70178	Horn, type 8H	1	-	1
29	F5359	Bracket	1	-	-
30	H1429	Bracket	-	-	1
31	F4771	Bolt (½ in. U.H.)	2	-	2
32	GS299	Serrated washer	2	-	2
33	70145	Horn, type HF 1950	-	1	-
34	H1304	Bracket	-	1	-
35	F5008	Screw (7/8 in. U.H.)	-	3	-
36	E2880	Serrated washer	-	3	-
37	H691	Nut	-	3	-
38	49072	Rectifier, type DS 506	1	-	1
39	F5338	Nut	1	-	-
40	F5431	Extended nut	-	-	1
41	E2287	Serrated washer	-	-	1
42	S1-51	Nut	-	-	1

See Page 65 for connectors
† 59004 Headlamp used on U.S.A. T20 model

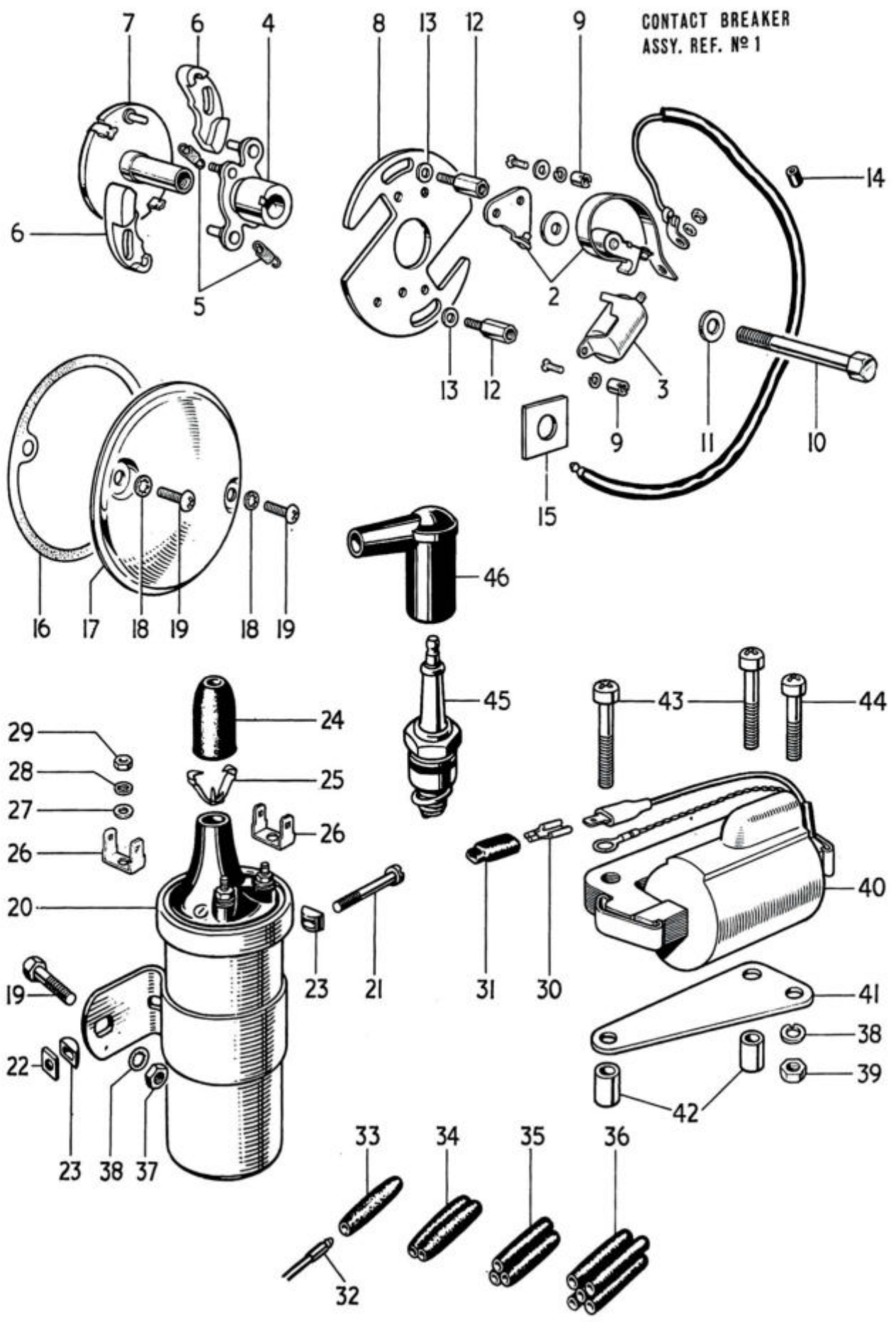

Fig. 24. CONTACT BREAKER AND IGNITION COILS

Ref. No.	Part No.	DESCRIPTION	T20	T20SS	T20SH
1	47604	CONTACT BREAKER, type 4CA	1	-	1
1	47603	CONTACT BREAKER, type 4CA	-	1	-
2	54415803	Contact set	1	1	1
3	425377	Condenser	1	1	1
4	54440029	Cam	1	-	1
4	54415053	Cam	-	1	-
5	425768	Spring set	1	-	1
5	54415640	Spring set	-	1	-
6	54440031	Weight	2	2	2
7	54415655	Sleeve and action plate	1	-	1
7	54415749	Sleeve and action plate	-	1	-
8	425370	Base plate	1	1	1
9	169194	Slotted nut	2	2	2
10	E5451	Bolt (2 in. U.H.)	1	1	1
11	S25-43	Plain washer	1	1	1
12	E4747	Pillar bolt ($\frac{1\frac{1}{2}}$ in. U.H.)	2	2	2
13	E2351	Plain washer	2	2	2
14	E4750	Grommet	1	1	1
15	E5050	Cable clip	1	1	1
16	E5049	Joint Washer	1	1	1
17	E4571	Cover	1	1	1
18	GS299	Serrated washer	2	2	2
19	F4715	Screw ($\frac{1\frac{1}{2}}$ in. U.H.)	2	2	2
20	45152	COIL, type MA.6	1	-	1
21	100104	Clip screw	1	-	1
22	169160	Square nut	1	-	1
23	422369	"D" washer	2	-	2
24	421554	Grommet	1	-	1
25	421863	Clip	1	-	1
26	54190108	Lucar terminal	2	-	2
27	131023	Plain washer (E2351)	2	-	2
28	188330	Serrated washer (GS299)	2	-	2
29	166043	Nut (F3799)	2	-	2
30	54942078	Lucar connector		As required	
31	54190042	Insulating cover		As required	
32	900269	Snap connector terminal		As required	
33	900288	Single snap connector		As required	
34	850641	Double snap connector		As required	
35	850844	Triple snap connector		As required	
36	850832	Quintuple snap connector		As required	
37	DS57	Bolt ($\frac{7}{16}$ in. U.H.)	2	-	2
38	E1612	Serrated washer	2	1	2
39	F879	Nut	2	1	2
40	45149	Ignition coil, type 3 ET	-	1	-
41	F5396	Bracket	-	1	-
42	F4374	Spacer	-	2	-
43	E3800	Screw ($\frac{7}{8}$ in. U.H.)	-	2	-
44	E3668	Screw ($\frac{5}{8}$ in. U.H.)	-	1	-
45	—	Sparking plug (Champion L7)	1	1	1
46	D297	Plug cover and suppressor	1	1	1
46	D262	Plug cover	A	A	A

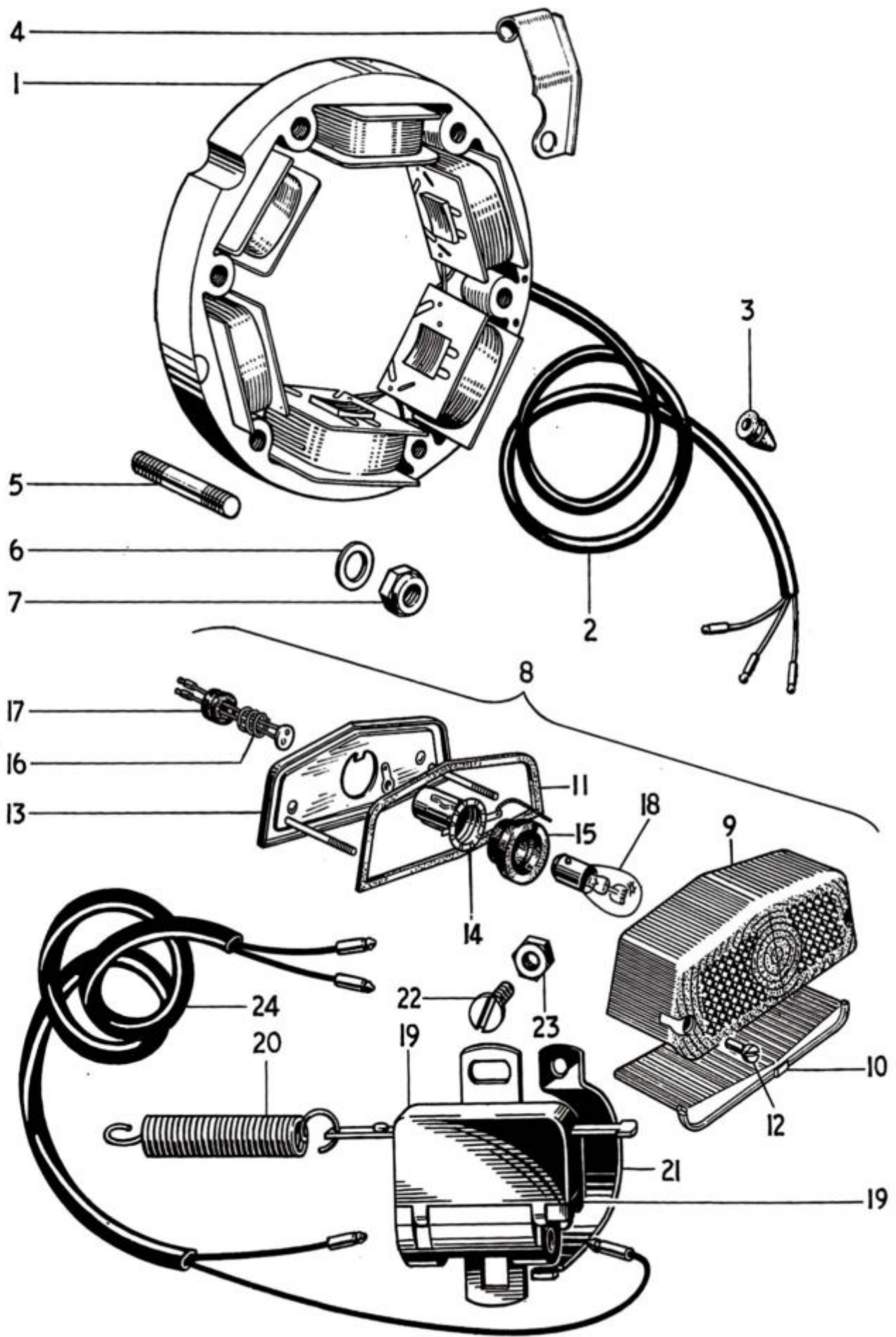
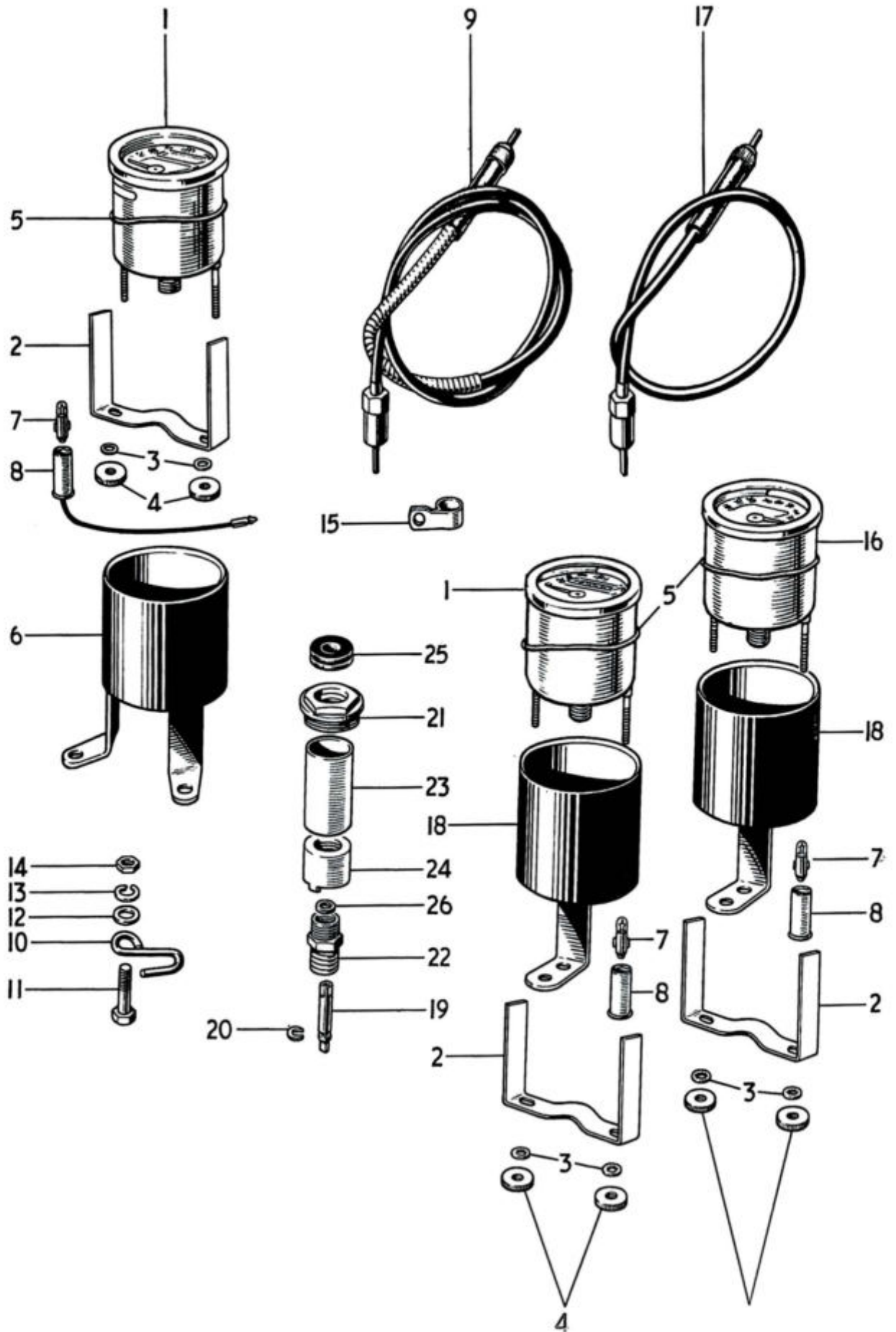

Fig. 25. STATOR, TAIL LAMP AND STOP LAMP SWITCH

STATOR, TAIL LAMP AND STOP LAMP SWITCH

										T20	T20SS	T20SH
1	47161	STATOR, type RM18	1	-	1
1	47173	STATOR, type RM19	-	1	-
2	54942271	Stator output cable	1	-	1
2	54944251	Stator output cable	-	1	-
3	D455	Grommet	1	1	1
4	E4485	Clip	1	1	1
5	E3171	Stud (1 $\frac{5}{32}$ in. O.A.)	5	-	5
5	E3718	Stud (1 $\frac{5}{16}$ in. O.A.)	-	5	-
6	E3302	Plain washer	4	-	4
6	S25-13	Plain washer	-	5	-
7	E5269	Self-locking nut	5	5	5
8	53394	STOP AND TAIL LAMP, Type 564	1	1	1
9	573839	Lens	1	1	1
10	575200	Window	1	1	1
11	575208	Lens seating gasket	1	1	1
12	575219	Sleeve nut	2	2	2
13	576002	Base assembly	1	1	1
14	575209	Bulbholder	1	1	1
15	575207	Grommet	1	1	1
16	573828	Contact assembly	1	1	1
17	573825	Grommet	1	1	1
18	352	Bulb (3/18W. Offset pin)	1	1	1
19	31437	Stop lamp switch	A	A	A
20	315738	Stop lamp switch spring	1	1	1
21	F4114	Switch bracket	1	1	1
22	H687	Bolt ($\frac{3}{8}$ in. U.H.)	1	1	1
23	H745	Nut	1	1	1
24	54941045	Stop switch lead	1	1	1



SPEEDOMETER AND TACHOMETER EQUIPMENT

			T20	T20SS	T20SH
SPEEDOMETER EQUIPMENT ONLY					
1	†SSM2001/00	SPEEDOMETER 80 M.P.H.	1	1	1
1	SSM2001/03	SPEEDOMETER 140 K.P.H.	A	A	A
2	31-647-187-01	Fixing strap	1	1	1
3	30-283-014-11	Serrated washer	2	2	2
4	30-271-014-11	Nut	2	2	2
5	31-753-720	Rubber ring	1	1	1
6	H1468	Speedometer cover	-	1	1
7	282	Bulb 0.6W BA7S	1	1	1
8	54935300	Bulbholder	1	1	1
9	D490	Speedometer cable	1	1	1
10	F5404	Speedometer cable steady	1	-	-
11	F1369	Bolt (5/8 in. U.H.) cable steady	1	-	-
12	S25-13	Plain washer, cable steady	1	-	-
13	S26-2	Spring washer, cable steady	1	-	-
14	F879	Nut, cable steady	1	-	-
15	F3098	Speedometer cable clip	1	-	-
TACHOMETER EQUIPMENT ONLY					
16	RSM2002/00	TACHOMETER HEAD 10,000 R.P.M.	-	1	1
2	31-647-187-01	Fixing strap	-	1	1
3	30-283-014-11	Serrated washer	-	2	2
4	30-271-014-11	Nut	-	2	2
5	31-753-720	Rubber ring	-	1	1
6	H1468	Tachometer cover	-	1	1
7	282	Bulb 0.6W BA7S	-	1	1
8	54935300	Bulbholder	-	1	1
17	D529	Tachometer cable	-	1	1
COMBINED SPEEDOMETER AND TACHOMETER EQUIPMENT					
1	SSM2001/00	SPEEDOMETER 80 M.P.H.	-	1	1
1	SSM2001/03	SPEEDOMETER 140 K.P.H.	-	A	A
16	RSM2002/00	TACHOMETER HEAD	-	1	1
2	31-647-187-01	Fixing strap	-	2	2
3	30-283-014-11	Serrated washer	-	4	4
4	30-271-014-11	Nut	-	4	4
5	31-753-720	Rubber ring	-	2	2
18	H1605	Instrument cover	-	2	2
7	282	Bulb 0.6W BA7S	-	2	2
8	54935300	Bulbholder	-	2	2
9	D490	Speedometer cable	-	1	1
17	D529	Tachometer cable	-	1	1
TACHOMETER DRIVE AND CRANKCASE					
19	D493	Tachometer cable spade	-	1	1
20	D494	Retaining washer	-	1	1
21	E4692	Adaptor for crankcase	-	1	1
22	E4699	Union	-	1	1
23	E4691	Spacer	-	1	1
24	E4690	Plug	-	1	1
25	F5332	Grommet	-	1	1
26	E4803	"O" Ring	-	1	1

† N.B. Speedometer equipment not used on TS20 model