

BRITCYCLE
www.britcycle.com.au

TRIUMPH

**REPLACEMENT
PARTS CATALOGUE**

No. 4

★

TWENTY-ONE (3TA)

SPEED TWIN (5TA)

TIGER 100 (T100A)

TIGER 100 (T100S/S)

FROM ENGINE No. 18612

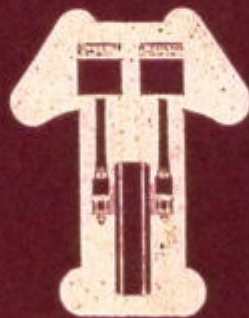

TRIUMPH GUARANTEE

1. In this Guarantee the word "machine" refers to the motor cycle, scooter, motor-cycle combination or sidecar as the case may be, purchased by the Purchaser.
2. In order to obtain the benefit of this Guarantee, the Purchaser must have correctly completed the registration form and returned it to us within fourteen days of the purchase.
3. We will supply, free of charge, a new part in exchange for, or, if we consider repair sufficient, will repair free of charge any part proved within six months of the date of purchase of any new machine, (3 months overseas) or within three months of its renewal or repair in the case of a part already renewed or repaired, to be defective by reason of our faulty workmanship or materials. We do not undertake to bear the cost of fitting such new or repaired part or accessory.
4. Any part considered to be defective must be sent to our Works, carriage paid, accompanied by the following information:—
 - (a) Name of purchaser and his address;
 - (b) Date of purchase of machine;
 - (c) Name of dealer from whom the purchase was made;
 - (d) Engine number and model.
5. This Guarantee shall not extend to defect or damage appearing after misuse, neglect, abnormal stress or strain, or the incorporation or affixing of unsuitable attachments or parts and in particular:—
 - (a) Hiring out;
 - (b) Racing and Competitions;
 - (c) Adaptation or alteration of any part or parts after leaving our Works;
 - (d) The attaching of a sidecar in a manner not approved by us or to an unsuitable motor-cycle.

This Guarantee shall not extend to machines whose trade mark, name or manufacturing number has been altered or removed, or in which has been used any part not supplied or approved by us, or to tyres, saddles, chains, speedometers, revolution counters and electrical equipment or to parts supplied to the order of the Purchaser and different from our standard specification.
6. Our liability and that of our dealer who sells the machine, shall be limited to that set out in this guarantee, and no other claims for consequential damage or injury to person or property, shall be admissible. All other conditions and warranties statutory or otherwise and whether express or implied are hereby excluded and no guarantee other than that expressly herein contained applies to the machine to which this Guarantee relates or any accessory or part thereof.
7. We reserve the right to modify or deviate from the Published Specification without notice.

REPAIRS GUARANTEE

1. Whilst the highest standard of workmanship and materials is aimed at, we cannot accept liability for any defects appearing more than three months after the machine, assembly or component has left our Works after being repaired.
2. We will repair or replace at our option free of charge any defective work, materials or parts relating to the repairs carried out by us appearing within that time but shall not be under any further or other, liability for any other loss or damage whether direct or consequential and our liability shall be limited to the cost of so making good. We do not undertake to bear the cost of fitting any replacement or repaired part.
3. We do not accept liability in respect of parts of proprietary manufacture, e.g. tyres, saddles, chains, speedometers, revolution counters and electrical equipment which may be used by us in effecting a repair. All other conditions and warranties statutory or otherwise express or implied are hereby excluded.

TRIUMPH SPARES

HOW TO ORDER. Every part is indicated by number, and this should be quoted together with the description. In order to assist customers, dimensions have been given in many cases where parts are similar. Parts where possible have been listed in order of assembly and a number of the illustrations show the assembly order also. With these aids there should be no difficulty in identifying the parts you require. **Always head your order with the engine number, stamped on the left side of the crank case underneath the cylinder flange, together with the prefix letters.**

WHERE TO OBTAIN. Triumph Spare Parts can only be obtained from an authorised Triumph Dealer, and we recommend our customers to place their orders with the Triumph Dealer in their district. When parts not usually asked for are required, and for which the Dealer may have to write or obtain specially, the postage or carriage incurred becomes payable.

Triumph Spares are not supplied to private owners direct from the factory. A list of authorised dealers who stock Triumph spares is published overleaf. If difficulty is experienced in obtaining the required parts, the matter should be taken up directly with the Triumph Spares Department.

Customers are warned against the risk incurred by purchasing parts that are not of genuine Triumph manufacture. This risk is eliminated if parts are ordered as instructed from recognised Dealers.

PATTERNS AND PARTS FOR REPAIR. It is not necessary to send patterns if the part number is quoted. The sending of patterns often delays the order as parcel post or rail takes longer than letter post.

Parts sent to Coventry for repair, replacement, or as patterns should bear the sender's name and address and clear instructions should accompany the parts. In your own interest send a copy of the advice note under separate cover. All parts must be forwarded carriage paid and care should be taken to ensure that all remittances are sent separately and not enclosed with the parts. Fragile units such as cylinders, etc., should always be boxed to avoid damage in transit. Complete machines should have all fittings such as windscreens, driving mirrors, tools, etc., removed by the sender before despatch, as it is impossible for us to accept responsibility in the event of loss in transit. We are always pleased to give estimates for overhauling and repairs, but should an estimate not be accepted, a charge will be made covering cost of dismantling and re-assembling, if carried out.

Communications relating to Parts should be addressed to the SPARES DEPARTMENT and for repairs, guarantee claims and technical advice to the SERVICE DEPARTMENT, Triumph Engineering Co. Ltd., Meriden Works, Allesley, Coventry. In order to facilitate quick reference, the quoting of any number, invoice number or reference from previous communications is essential. Accessories not of our manufacture should be sent direct to the actual makers, whose names and addresses appear below.

PROPRIETARY GROUP

Ancillary equipment which is fitted to our motor cycles is of the highest quality and is guaranteed by the manufacturer and not by ourselves. Any repairs or claims should be made to the actual makers or their local agents who will always give owners every possible assistance. The following are the addresses of the various manufacturers:—

CARBURETTORS

Messrs. Amal Ltd.,
Holdford Rd., Witton, Birmingham 6.

CHAINS

Renold Chains Ltd.,
Wythenshawe, Manchester.

ELECTRICAL EQUIPMENT

Messrs J. Lucas Ltd.,
Gt. Hampton St., Birmingham, 18.

TYRES

Dunlop Rubber Co. Ltd.,
Fort Dunlop,
Birmingham, 24.

SPARKING PLUGS

Champion Sparking Plug Co. Ltd.,
Feltham, Middlesex.

K.L.G. Sparking Plugs Ltd.,

Cricklewood Works, London, N.W.2.

Lodge Plugs Ltd.,

Rugby, Warwickshire.

SPEEDOMETERS

Messrs. Smiths Motor Accessories Ltd.,
Cricklewood Works, London, N.W.2.

SUSPENSION UNITS

Messrs. Girling Ltd.,
Kings Road, Tyseley, Birmingham, 11.

ILLUSTRATION INDEX

<i>Fig. No.</i>	<i>Description</i>	<i>Page No.</i>
1	CRANKCASE AND CONNECTING RODS	16
2	CRANKCASE	18
3	OIL PUMP, RELEASE VALVE AND INLET MANIFOLD	20
4	CYLINDER BLOCK AND HEAD 3TA	22
5	CYLINDER BLOCK AND HEAD 5TA, T100A and T100SS	24
6	GEARBOX SHAFTS, BEARINGS AND INNER COVER	26
7	GEARBOX OUTER COVER AND LEVERS	28
8	CLUTCH	30
9	CHAINCASE AND CHAINS	32
10	ENGINE FITTINGS AND EXHAUST SYSTEM	34
11	ENGINE FITTINGS AND 2 INTO 1 EXHAUST SYSTEM	36
12	FRAME	38
13	SWINGING FORK, SUSPENSION UNITS AND CHAINGUARD	40
14	TELESCOPIC FRONT FORK	42
15	NACELLE, HEADLAMP AND SWITCHES	44
16	TELESCOPIC FRONT FORK T100SS	46
17	FRONT WHEEL	48
18	REAR WHEEL	50
19	QUICKLY DETACHABLE REAR WHEEL	52
20	MUDGUARDS AND REAR PANELS	54
21	MUDGUARDS AND REAR PANELS, T100SS	56
22	TWINSEAT AND TOOLKIT	58
23	PETROL AND OIL TANKS	60
24	T100SS OIL TANK, Etc.	62
25	CONTROL CABLES, BATTERY CARRIER AND AIR FILTER	64
26	HANDLEBAR AND CONTROL LEVERS	66
27	T100SS HANDLEBAR AND CONTROL LEVERS	68
28	CARBURETTER, 3TA & 5TA	70
29	CARBURETTER, T100A & T100SS	72
30	DISTRIBUTOR, COIL AND SPARK PLUGS	74
31	T100SS HEADLAMP, WIRING HARNESS AND SWITCH	76
32	SPEEDOMETER, STOP AND TAIL LAMP AND RECTIFIER	78

INDEX

	<i>Page</i>		<i>Page</i>
AIR FILTER	62, 64	MANIFOLD	20
ALTERNATOR	16, 32	MUDGUARDS	54, 56
BATTERY CARRIER	62, 64	NACELLE	44
CARBURETTER	70, 72	OIL PUMP	20
CARTON PACKS	14	OIL TANK	60, 62
CENTRE STAND	38	PETROL TANK	60
CHAINCASE	32	PILLION FOOTRESTS	38
CHAINS	32	PISTONS	16
CLUTCH	30	PROP STAND	38
COIL	74	Q.D. REAR WHEEL	52
CONTROL CABLES	64	REAR PANELS	54, 56
CONTROL LEVERS	66, 68	REAR WHEEL	50
CRANKCASE	18	RECTIFIER	78
CRANKSHAFT	16	SILENCERS	34, 36
CYLINDER HEAD	22, 24	SPARK PLUGS	74
DISTRIBUTOR	74	SPEEDOMETER	78
ENGINE PLATES	34, 36	STEERING RACES	38
EXHAUST PIPES	34, 36	SUSPENSION UNITS	40
FOOTRESTS	38	SWITCHES	44, 76
FRONT FORKS	42, 46	TIMING GEARS	16
FRONT WHEEL	48	TOOLKIT	58
GASKET SETS	15	TWINSEAT	58
GEARBOX	26, 28	VALVES	22, 24
HANDLEBARS	66, 68	WIRING HARNESS	44, 76
HORN	44		

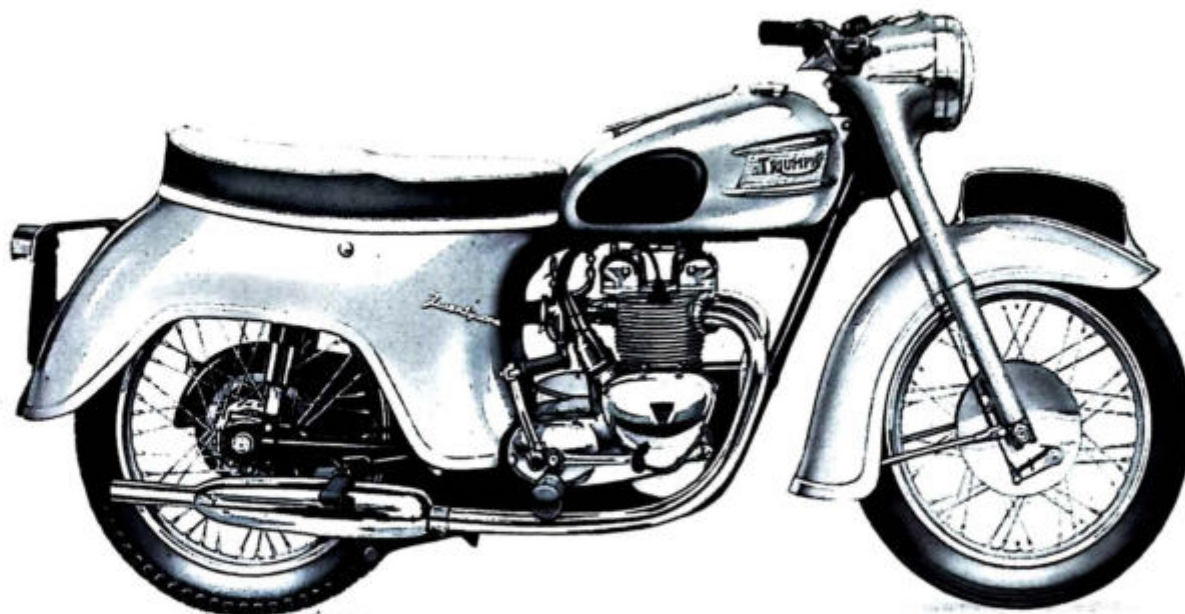

TWENTY-ONE (3TA) TECHNICAL DATA

Bore and stroke		58.25 x 65.5 mm. 2.292 in. x 2.578 ins.
Capacity		348 c.c. (21.23 cu. ins.).
Compression Ratio		7.5 : 1
Sparking Plugs	Champion N4, K.L.G., FE75 or Lodge HLN	
Carburetter		Amal Monobloc 375
	Main Jet	100
	Needle Jet	.106
	Needle	Type B
	Throttle Valve	375/3½
	Pilot Jet	25
Gearbox Sprocket		18 teeth
Chains	Front	¾ in. Duplex x 78 links
	Rear	¾ in. x ¾ in. x 100 links
Capacities	Fuel Tank	3½ galls. (16 litres)
	Oil Tank	5 pints (2.8 litres)
	Gearbox	2/3 pint (375 c.c.)
	Primary Chaincase	½ pint (300 c.c.)
	Front Forks (each leg)	¼ pint (150 c.c.)
Brakes	Front and Rear, diameter	7 in. (17.78 cm.)
Tyre Size	Front	3.25 x 17
	Rear	3.25 x 17



SPEED TWIN (5TA) TECHNICAL DATA

Bore and Stroke		69 x 65.5 mm. 2.716 x 2.578 ins.
Capacity		490 c.c. (29.8 cu. ins.)
Compression Ratio		7 : 1
Sparking Plugs	Champion N4, K.L.G. FE75 or Lodge HLN	
Carburetter		Amal Monobloc 375
	Main Jet	160
	Needle Jet	.105
	Needle	Type B
	Throttle Valve	375/3
	Pilot Jet	25
Gearbox Sprocket		19 teeth
Chains	Front	$\frac{3}{8}$ in. Duplex x 78 links
	Rear	$\frac{5}{8}$ in. x $\frac{3}{8}$ in. x 101 links
Capacities	Fuel Tank	3½ galls. (16 litres)
	Oil Tank	5 pints (2.8 litres)
	Gearbox	2/3 pint (375 c.c.)
	Primary Chaincase	½ pint (300 c.c.)
	Front Forks (each leg)	¼ pint (150 c.c.)
Brakes	Front and Rear, diameter	7 in. (17.78 cm.)
Tyre Size	Front	3.25 x 17
	Rear	3.50 x 17

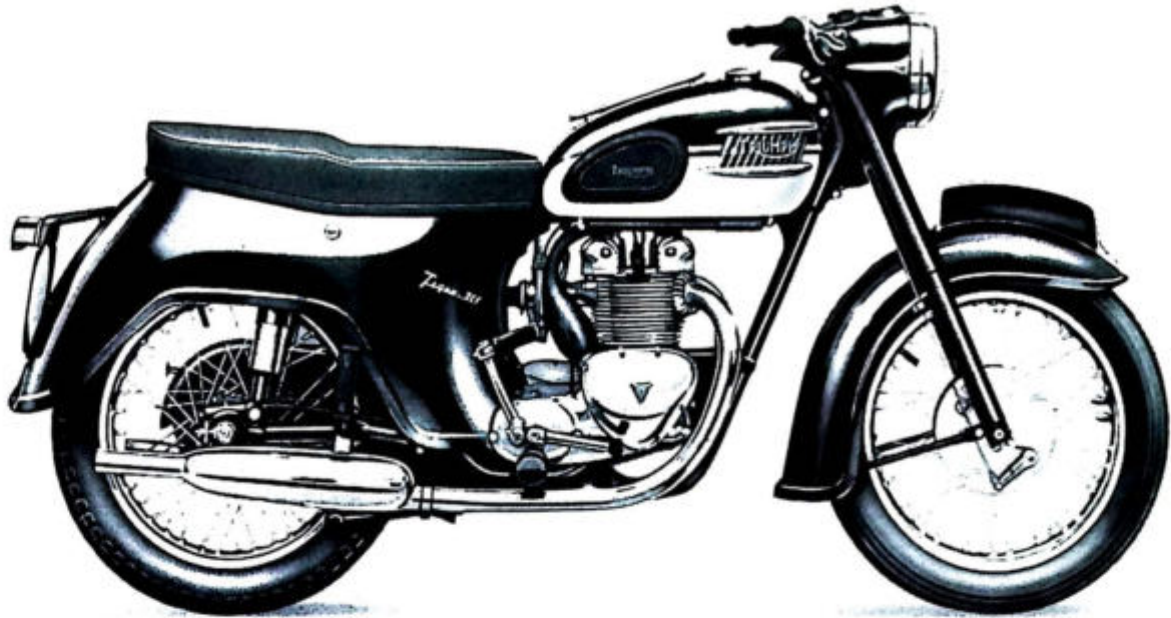

TIGER 100 (T100A) TECHNICAL DATA

Bore and Stroke		69 x 65.5 mm. 2.716 x 2.578 ins.
Capacity		490 c.c. (29.8 cu. ins.)
Compression Ratio		9 : 1
Sparking Plugs	Champion N4, K.L.G. FE75 or Lodge HLN	
Carburetter		Amal Monobloc
	Main Jet	190
	Needle Jet	.106
	Needle	Type C
	Throttle Valve	376/3½
	Pilot Jet	25
Gearbox Sprocket		19 teeth
Chains	Front	¾ in. Duplex x 78 links
	Rear	¾ in. x ¾ in. x 101 links
Capacities	Fuel Tank	3½ galls. (16 litres)
	Oil Tank	5 pints (2.8 litres)
	Gearbox	2/3 pint (375 c.c.)
	Primary Chaincase	½ pint (300 c.c.)
	Front Forks (each leg)	¼ pint (150 c.c.)
Brakes	Front and Rear, diameter	7 in. (17.78 cm.)
Tyre Size	Front	3.25 x 17
	Rear	3.50 x 17



TIGER 100 (T100SS) TECHNICAL DATA

Bore and Stroke		69 x 65.5 mm. 2.716 x 2.578 ins.
Capacity		490 c.c. (29.8 cu. ins.)
Compression Ratio		9 : 1
Sparking Plugs	Champion N4, K.L.G. FE75 or Lodge HLN	
Carburettor		Amal Monobloc
	Main Jet	190
	Needle Jet	.106
	Needle	Type C
	Throttle Valve	376/3½
	Pilot Jet	25
Gearbox Sprocket		18 teeth
Chains	Front	¾ in. Duplex x 78 links
	Rear	5/8 in. x ¾ in. x 101 links
Capacities	Fuel Tank	3½ galls. (16 litres)
	Oil Tank	5 pints (2.8 litres)
	Gearbox	2/3 pint (375 c.c.)
	Primary Chaincase	½ pint (300 c.c.)
	Front Forks (each leg)	¼ pint (150 c.c.)
Brakes	Front and Rear, diameter	7 in. (17.18 cm.)
Tyre Size	Front	3.25 x 19
	Rear	3.50 x 18

CARTON PACK LIST

The following sub-assemblies are supplied in carton packs under the C.P. part number stated. The contents of these carton packs are preserved and will not deteriorate under adverse conditions.

Part No.	Contents	
Brake Lining CP 38/AM2	2 NW243 16 W129	Brake Lining Rivet
Crankcase Bearings C.P. 169	1 E4137 1 E3835	Main bearing Main bearing (ball journal)
Fork Service Pack C.P. 168	2 H420 4 H430 2 H441 2 H443 2 H1062 2 H1168	Rubber washer Fibre washer Upper bearing Lower bearing Aluminium washer Oil seal
Steering Races C.P. 167	1 H1110 1 H1140 2 H1130 48 S70-4	Cone Cone and dust cover Cup Steel balls (3/16 in. diam.)
Pistons (350 c.c.) C.P. 164	1 E3689 1 E3691 1 E3690 1 E3692 1 E1750 2 E1767	Piston C.R. 7.5 : 1 Compression ring (plain) Compression ring (taper) Oil control ring Gudgeon pin Circlips
C.P. 164 is also available in 0.010 in., 0.020 in. and 0.040 in. oversizes.		
Piston Rings (350 c.c.) C.P. 165	2 E3691 2 E3690 2 E3692	Compression ring (plain) Compression ring (taper) Oil control ring
C.P. 165 is also available in 0.010 in., 0.020 in. and 0.040 in. oversizes.		
Pistons (500 c.c.) C.P. 174	1 E4004 2 E3829 1 E3831 1 WE203E 2 WE479	Piston C.R. 7 : 1 Compression ring (taper) Oil control ring Gudgeon pin Circlips
C.P. 174 is also available in 0.010 in. and 0.020 in. oversizes.		
Pistons (500 c.c.) C.P. 179	1 E4021 2 E3829 1 E3831 1 WE203E 2 WE479	Piston C.R. 9 : 1 Compression ring (taper) Oil control ring Gudgeon pin Circlips
C.P. 179 is also available in 0.010 in. and 0.020 in. oversizes.		
Piston Rings (500 c.c.) C.P. 175	4 E3829 2 E3831	Compression ring (taper) Oil control ring
C.P. 175 is also available in 0.010 in. and 0.020 in. oversizes.		

CARTON PACK LIST—continued

<i>Part No.</i>	<i>Contents</i>	
C.P. 180	4 E4135 2 E4136	Compression ring (taper) Oil control rings
C.P. 180 can only be fitted to E4021 Piston body, and should only be used for high-performance work.		
Valve Guides		
C.P. 170	4 E3208 4 E3209	Valve guides Valve guides circlip
Valves (350 c.c.)		
C.P. 166	2 E3738 2 E3739	Inlet valve Exhaust valve
Valve Springs (350 c.c.)		
C.P. 171	4 E3942 4 E3741	Inner valve spring Outer valve spring
Valves (500 c.c.)		
C.P. 176	2 E4012 2 E4013	Inlet valve Exhaust valve
Valve Springs (500 c.c.)		
C.P. 177	4 E4010 4 E4011	Inner valve spring Outer valve spring

Gasket Set	All models	GS T21/57
-------------------	------------	-----------

PLEASE NOTE

THROUGHOUT THIS LIST, ASSEMBLIES ARE PRINTED IN CAPITALS AND THE COMPONENTS INCLUDED IN THAT ASSEMBLY ARE INDENTED IN THE DESCRIPTION COLUMN, REVERTING TO THE ORIGINAL ALIGNMENT WHEN THE ASSEMBLY IS COMPLETE. TO ORDER THE COMPLETE ASSEMBLY IT IS NECESSARY ONLY TO QUOTE THE ASSEMBLY NUMBER. ANY COMPONENT PARTS LISTED MAY ALSO BE OBTAINED SEPARATELY IF REQUIRED.

SPECIAL WORKSHOP TOOLS

A COMPLETE LIST OF WORKSHOP TOOLS CAN BE MADE AVAILABLE BY EITHER CONTACTING YOUR DEALER APPLYING DIRECT TO THE TRIUMPH SERVICE DEPARTMENT. IN MOST CASES THESE TOOLS ARE VERY COSTLY AS THEY ARE MADE ENTIRELY FOR WORKSHOP USE, AND THEREFORE, IT IS NOT RECOMMENDED THAT THE PRIVATE OWNER PURCHASES THE TOOLS IN ORDER TO AID SERVICING THE MACHINE ONCE OR TWICE ONLY. IN THESE CIRCUMSTANCES IT IS FAR MORE ECONOMICAL TO GET IN TOUCH WITH A RECOGNISED DEALER.

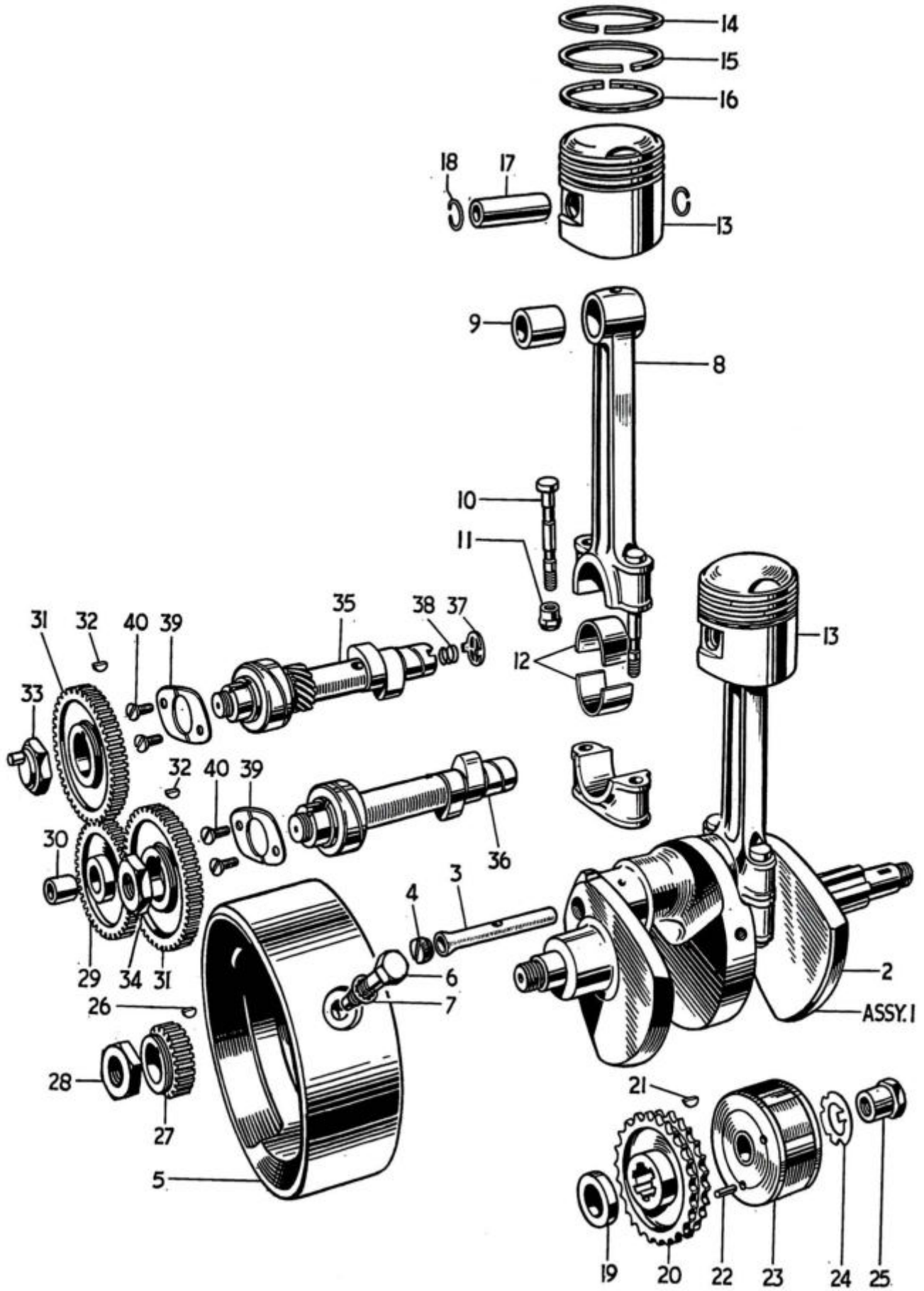

Fig. 1. CRANKSHAFT AND CONNECTING RODS.

CRANKSHAFT AND CONNECTING RODS

								3TA	5TA	T100A	T100SS
1	E3996	CRANKSHAFT AND FLYWHEEL ASSEMBLY	1	1	1	1
2	E3998	Crankshaft	1	1	1	1
3	E3999	Oil tube	1	1	1	1
4	E3711	Screwed plug	1	1	1	1
5	E3712	Flywheel	1	1	1	1
6	E3713	Flywheel bolt...	3	3	3	3
7	E2288	Serrated washer	3	3	3	3
8	E3702	CONNECTING ROD	2	—	—	—
8	E4001	CONNECTING ROD	—	2	2	2
9	E1762	Small end bush	2	—	—	—
9	E4003	Small end bush	—	2	2	2
10	E3705	Connecting rod bolt	2	2	2	2
11	E2922	Self locking nut	2	2	2	2
12	E3706	Big end bearing	4	4	4	4
13	CP164	PISTON COMPLETE C.R. 7.5 : 1	2	—	—	—
13	CP174	PISTON COMPLETE C.R. 7 : 1	—	2	—	—
13	CP179	PISTON COMPLETE C.R. 9 : 1	—	—	2	2
14	E3691	Plain compression ring	2	—	—	—
14	E3829	Taper compression ring	—	2	2	2
15	E3690	Taper compression ring	2	—	—	—
15	E3829	Taper compression ring	—	2	2	2
16	E3692	Oil control ring	2	—	—	—
16	E3831	Oil control ring	—	2	2	2
17	E1750	Gudgeon pin	2	—	—	—
17	WE203E	Gudgeon pin	—	2	2	2
18	E1767	Circlip	4	—	—	—
18	WE479	Circlip	—	4	4	4
19	E4006	Distance collar	1	1	1	1
20	E4141	Engine sprocket, 26T Duplex	1	1	1	1
21	E3851	Rotor key	1	1	—	—
22	E4142	Rotor dowel	—	—	1	1
23	†423506	Rotor	1	1	—	—
23	†54211595	Rotor	—	—	1	—
24	E3852	Tab washer	1	1	1	1
25	E3735	Nut	1	1	1	1
26	E1580	Key	1	1	1	1
27	E1771	Timing pinion	1	1	1	1
28	E398	Nut	1	1	1	1
29	E2202	INTERMEDIATE WHEEL	1	1	1	1
30	E400	Bush	1	1	1	1
31	E1486A	Camshaft wheel	2	2	2	2
32	E1558	Camshaft key	2	2	2	2
33	E1463	Inlet camshaft nut	1	1	1	1
34	E1492	Exhaust camshaft nut	1	1	1	1
35	E3838	Inlet camshaft	1	1	—	—
35	E4038	Inlet camshaft	—	—	1	1
36	E3839	Exhaust camshaft	1	1	—	—
36	E4039	Exhaust camshaft	—	—	1	—
36	E4023	Exhaust camshaft	—	—	—	1
37	E2254	Rotary breather valve	1	1	1	—
38	E2256	Breather valve spring	1	1	1	—
39	E3727	Retaining plate	2	2	2	—
40	E3728	Screw (1 1/2 in. U.H.)	4	4	4	—

†From engine No. H25252 use

23 54213901

Rotor RM. 19

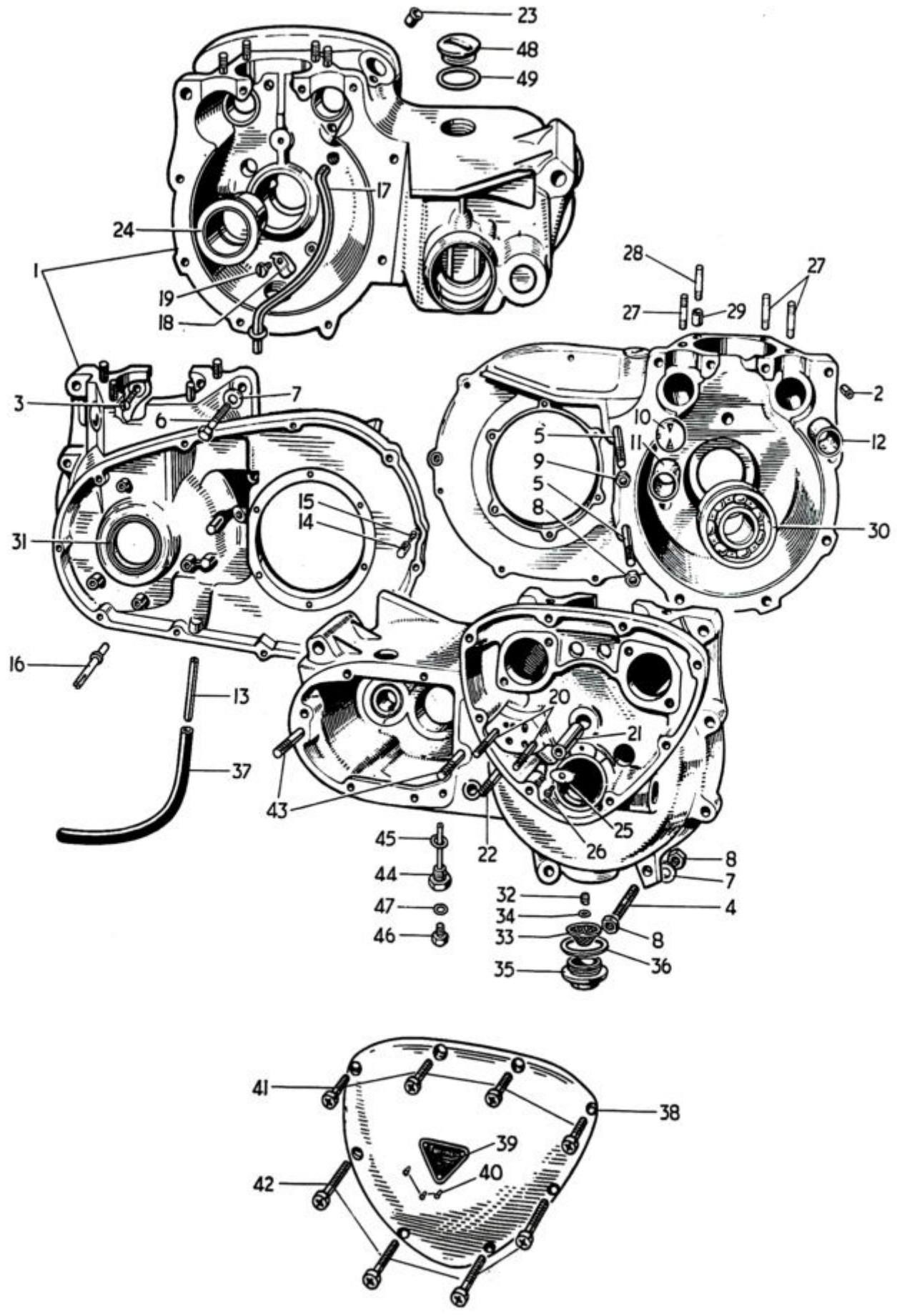

Fig 2. CRANKCASE

Ref. No.	Part No.	DESCRIPTION	3TA	5TA	T100A	T100SS
CRANKCASE						
1	E3688/4005	CRANKCASE c/w STUDS AND RIGHT MAIN BEARING	1	1	1	1
2	E3716	Hollow dowel	1	1	1	1
3	E3859	Screw ($\frac{3}{16}$ in. U.H.)	2	2	2	2
4	E3804	Stud (3 in. O.A.)	1	1	1	1
5	E3803	Stud ($3\frac{3}{4}$ in. O.A.)	2	2	2	2
6	E3799	Bolt ($1\frac{5}{8}$ in. U.H.)	1	1	1	1
7	S25-3	Plain washer	3	3	3	3
8	S1-51	Nut	3	3	3	1
9	E1310	Nut	1	1	1	3
10	E3822	Breather disc	1	1	1	1
11	E3824	Inlet camshaft bush	1	1	1	1
12	E3823	Exhaust camshaft bush	1	1	1	1
13	E2724	Breather pipe	1	1	1	1
14	E3884	Chain oiler tube	1	1	1	1
15	E3885	Chain oiler jet	1	1	1	1
16	E4147	Chain tensioner abutment	1	1	1	1
17	E3719	Oil scavenge pipe	1	1	1	1
18	E1509	Clip	1	1	1	1
19	E1645	Screw ($\frac{17}{64}$ in. U.H.)	1	1	1	1
20	E3718	Oil pump stud ($1\frac{1}{8}$ in. O.A.)	2	2	2	2
21	E375	Intermediate wheel spindle	1	1	1	1
22	E3717	Oil pipes stud ($1\frac{1}{2}$ in. O.A.)	1	1	1	1
23	E3877	Distributor shaft bush	1	1	1	1
24	E4137	Right main bearing	1	1	1	1
25	E4139	Locating plate	1	1	1	1
26	E4140	Self tapping screw	1	1	1	1
27	E3820	Cylinder stud ($1\frac{1}{2}$ in. O.A.)... ..	6	6	6	6
28	E3819	Cylinder stud ($1\frac{1}{4}$ in. O.A.)	2	2	2	2
29	E1534A	Dowel	2	2	2	2
30	E3835	Left main bearing (ball journal)	1	1	1	1
31	E3876	Oil seal	1	1	1	1
32	E3724	Filter spring	1	1	1	1
33	E3722	Filter	1	1	1	1
34	E3723	Sealing washer	1	1	1	1
35	E1564	Filter cap	1	1	1	1
36	E1577	Joint washer	1	1	1	1
37	E3078	Breather extension rubber pipe	1	1	1	1
38	E3693	TIMING COVER	1	1	1	1
39	E4016	Patent plate	1	1	1	1
40	D208-5	Patent plate rivet	1	1	1	1
41	E3800	Screw ($\frac{7}{8}$ in. U.H.)	4	4	4	4
42	E3801	Screw ($1\frac{1}{8}$ in. U.H.)	4	4	4	4
43	T1399	Stud ($3\frac{1}{8}$ in. O.A.)	2	2	2	2
44	T1112	Drain plug (with level tube)	1	1	1	1
45	WE170	Fibre washer	1	1	1	1
46	T361	Level plug	1	1	1	1
47	T1257	Fibre washer	1	1	1	1
48	E732	Filler plug	2	2	2	2
49	NE507	Fibre washer	2	2	2	2

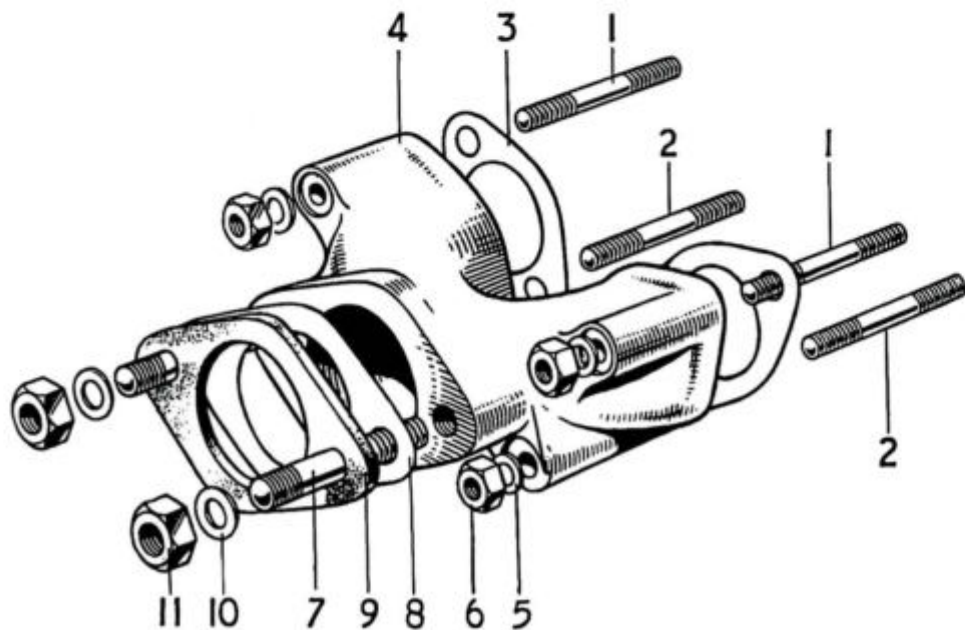
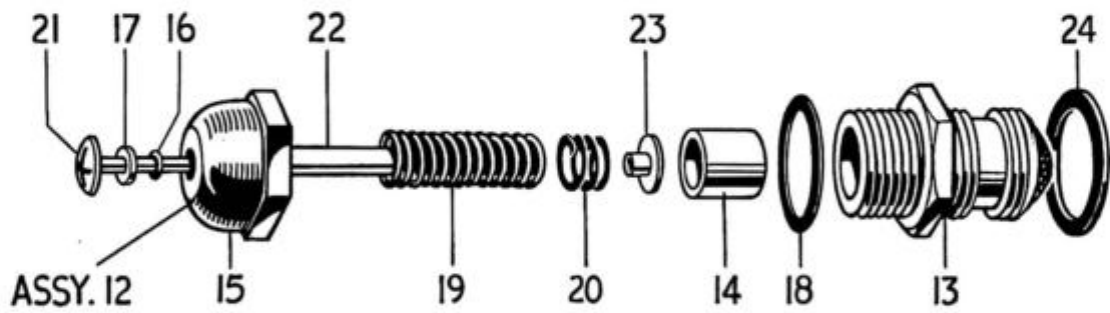
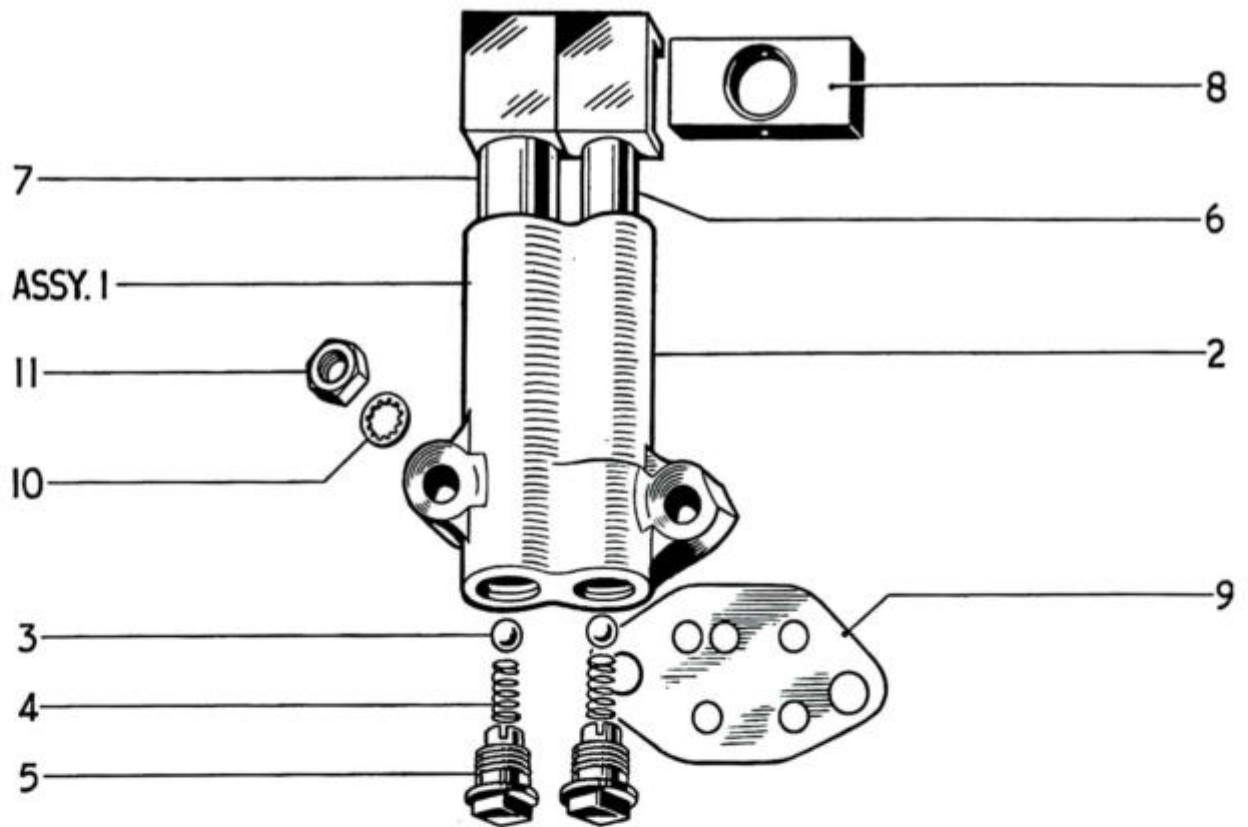

Fig. 3. OIL PUMP, RELEASE VALVE AND INLET MANIFOLD.

OIL PUMP AND RELEASE VALVE

									3TA	5TA	T100A	T100SS
1	E3878	OIL PUMP	1	1	1	1
2	E3731	Pump body	1	1	1	1
3	S70-7	Valve ball	2	2	2	2
4	E403	Valve spring	2	2	2	2
5	E2360	Screwed plug	2	2	2	2
6	GS153	Feed plunger	1	1	1	1
7	E1476	Scavenge plunger	1	1	1	1
8	E495	Drive block	1	1	1	1
9	E3730	Joint washer	1	1	1	1
10	E3887	Serrated washer	2	2	2	2
11	E3732	Nut	2	2	2	2
12	E4191	OIL RELEASE VALVE AND INDICATOR	1	1	1	1
13	E2794	Valve body	1	1	1	1
14	GS251	Piston	1	1	1	1
15	E4192	Cap	1	1	1	1
16	E4193	Sealing ring	1	1	1	1
17	E4194	Cup	1	1	1	1
18	GS254	Fibre washer	1	1	1	1
19	E2788	Main spring	1	1	1	1
20	E2789	Auxiliary spring	1	1	1	1
21	E2791	Button and shaft	1	1	1	1
22	E2793	Sealing rubber	1	1	1	1
23	E2792	Shaft nut	1	1	1	1
24	E1670	Fibre washer	1	1	1	1

INLET MANIFOLD

1	E3796	Stud (1 $\frac{1}{2}$ in. O.A.)	2	2	2	2
2	E3797	Stud (2 in. O.A.)	2	2	2	2
3	E2967	Joint washer	2	2	2	2
4	E4014	Inlet manifold	1	1	1	1
5	S25-13	Plain washer	4	4	4	4
6	W103	Nut	4	4	4	4
7	E3880	Stud (1 $\frac{1}{2}$ in. O.A.)	2	2	2	2
8	NA43	Joint washer	1	1	-	-
8	NA43A	Joint washer	-	-	1	1
9	E3834	Insulating block	1	1	-	-
9	E2968	Insulating block	-	-	1	1
10	S25-3	Plain washer	2	2	2	2
11	S1-51	Nut	2	2	2	2

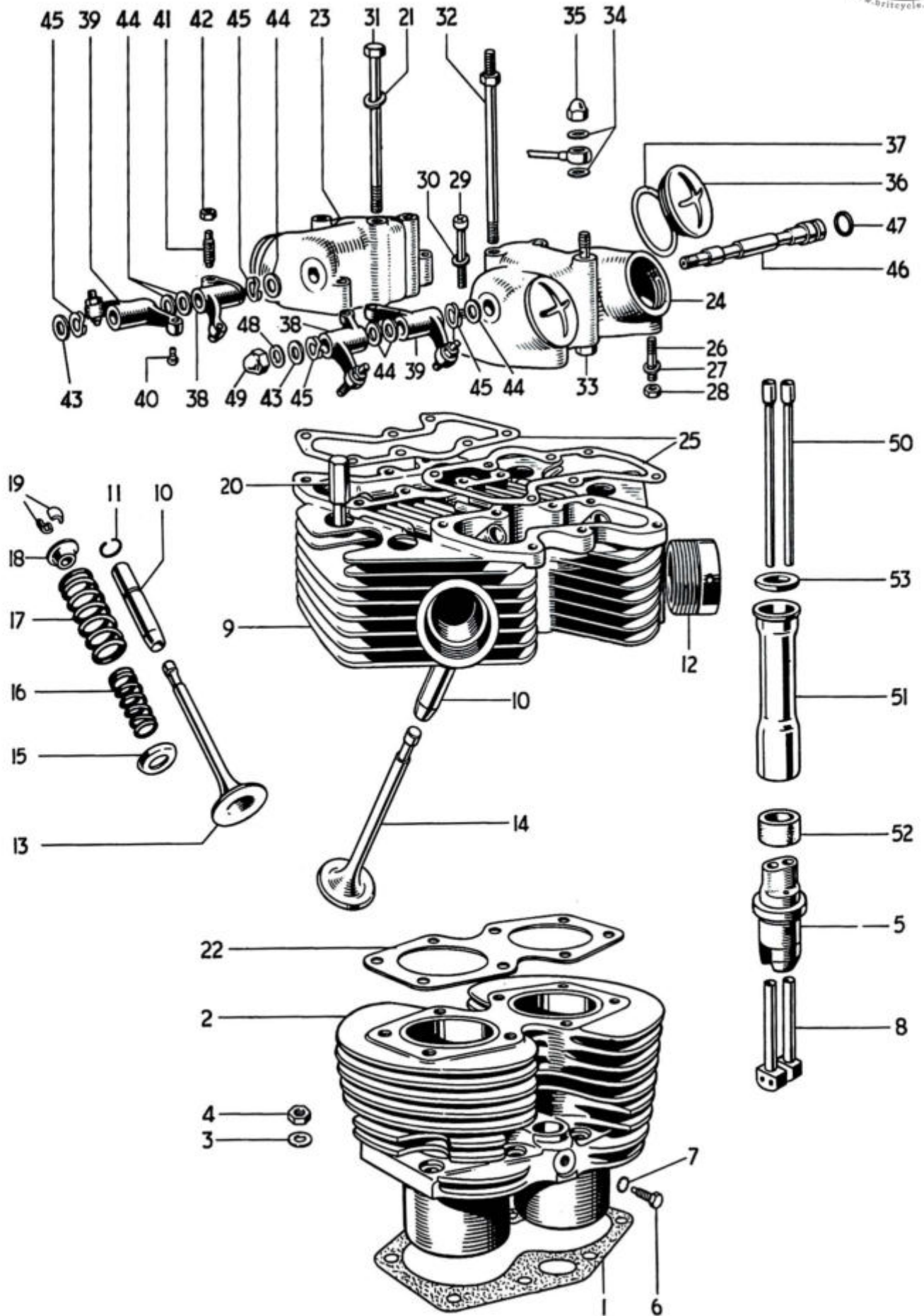

Fig. 4. CYLINDER BLOCK AND HEAD. 3TA.

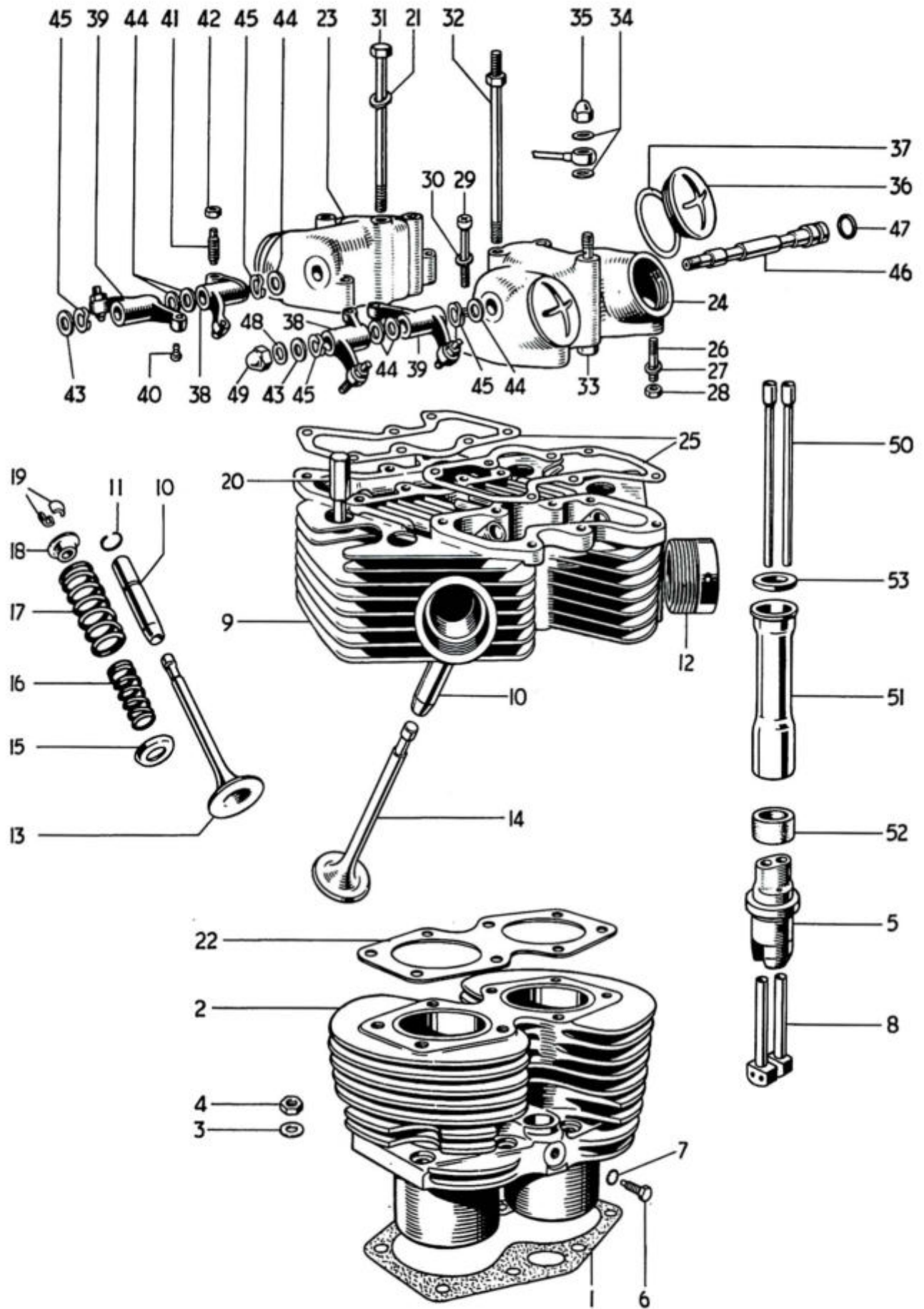

Fig. 5. CYLINDER BLOCK AND HEAD. 5TA & T100A

Ref. No.	Part No.	DESCRIPTION	5TA	T100A	T100SS
CYLINDER BLOCK HEAD AND 5TA, T100A and T100SS					
1	E3798	Cylinder base washer	1	1	1
2	E4000	Cylinder block	1	1	1
3	GS308	Plain washer	8	8	8
4	E2412	Nut	8	8	8
5	E3736	Tappet guide block	2	2	2
6	H200	Tappet block screw ($\frac{7}{8}$ in. U.H.)	2	2	2
7	E1612	Serrated washer	2	2	2
8	E3753	Tappet	4	4	4
9	E4007	CYLINDER HEAD c/w GUIDES	1	1	1
10	E3208	Valve guide	4	4	4
11	E3209	Valve guide circlip	4	4	4
12	E2961	Exhaust pipe adaptor	2	2	2
13	E4012	Inlet valve	2	2	2
14	E4013	Exhaust valve	2	2	2
15	E3740	Bottom cap	4	4	4
16	E4010	Inner valve spring	4	4	4
17	E4011	Outer valve spring	4	4	4
18	E3742	Top collar	4	4	4
19	WE259A	Split cotter	8	8	8
20	E4456	Cylinder head bolt (2 $\frac{25}{32}$ in. U.H.)	4	4	4
21	F2184	Plain washer	8	8	8
22	E4015	Cylinder head gasket	1	1	1
23	E3745	Inlet rocker box	1	1	1
24	E3744	Exhaust rocker box	1	1	1
25	E3743	Joint washer	2	2	2
26	E3858	Rocker box stud ($\frac{1}{8}$ in. O.A.)	4	4	4
27	E3302	Plain washer	4	4	4
28	F879	Nut	4	4	4
29	E3668	Screw ($\frac{1}{4}$ in. U.H.)	4	4	4
30	E3857	Plain washer	4	4	4
31	E3794	Cylinder head bolt (5 $\frac{7}{8}$ in. U.H.)	2	2	2
32	E3795	Cylinder head torque stay bolt	2	2	2
33	E3809	Oil feed bolt	2	2	2
34	F1880	Copper washer	6	6	6
35	H400	Domed nut	2	2	2
36	E3752	Inspection cap	4	4	4
37	E3751	Joint washer	4	4	4
38	E3749	ROCKER (Right exhaust, left inlet)	2	2	2
39	E3750	ROCKER (Left exhaust, right inlet)	2	2	2
40	E3222	Rocker ball pin	4	4	4
41	E3223	Rocker adjusting pin	4	4	4
42	GS662	Adjuster lock nut	4	4	4
43	E1330	Thrust washer $\frac{3}{8}$ in.	2	2	2
44	E2534	Thrust washer $\frac{7}{8}$ in.	6	6	6
45	E3224	Spring washer	4	4	4
46	E3748	Rocker spindle	2	2	2
47	E3253	Sealing rubber	2	2	2
48	E1335	Copper washer	2	2	2
49	E1435	Domed nut	2	2	2
50	E4008	Push rod	4	4	4
51	E3755	Cover tube	2	2	2
52	E3758	Bottom joint washer	2	2	2
53	E3547	Top joint washer	2	2	2

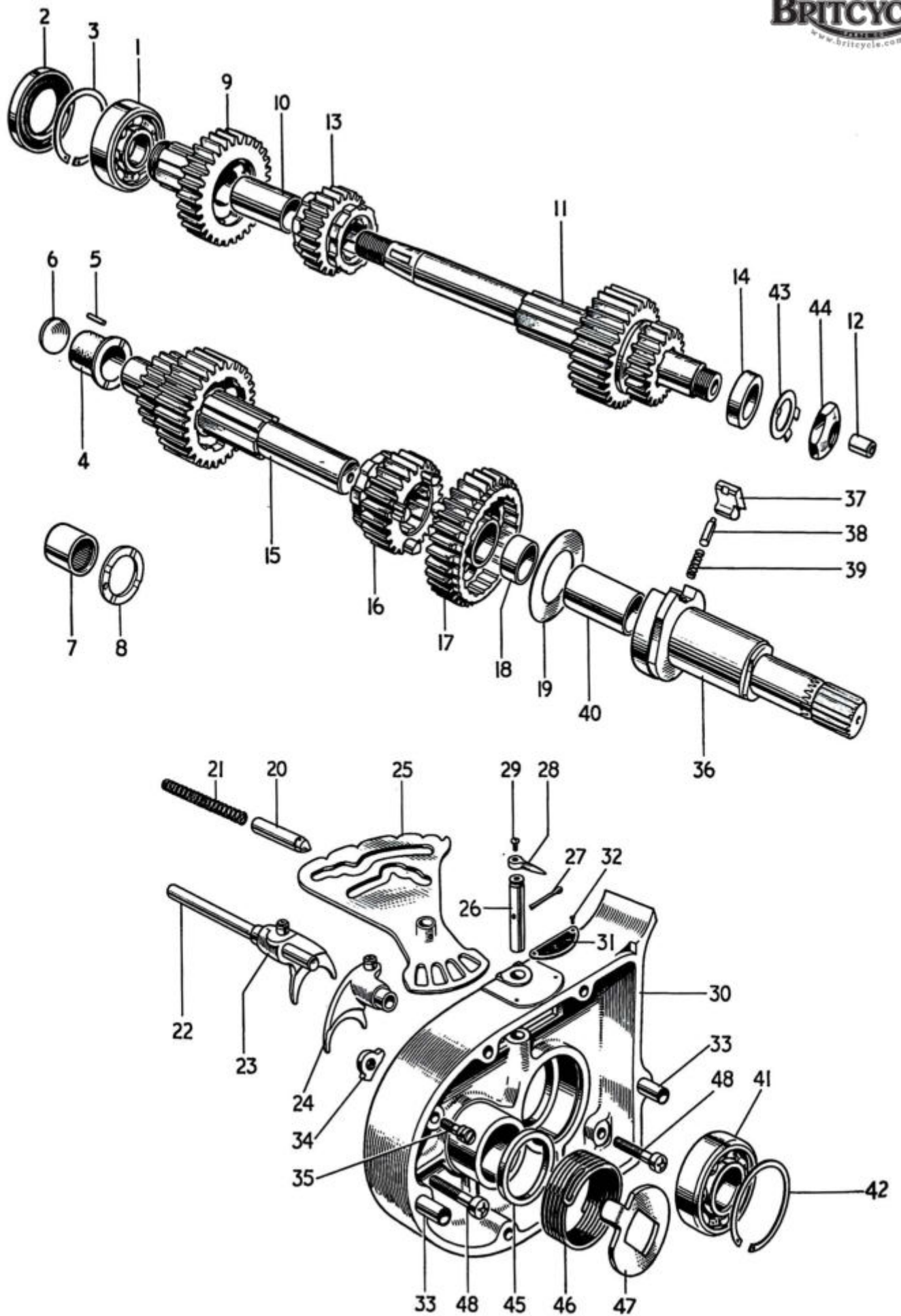

Fig. 6. GEARBOX SHAFTS, BEARINGS AND INNER COVER.

GEARBOX SHAFTS, BEARINGS AND INNER COVER

									3TA	5TA	T100A	T100SS
1	T665	High gear bearing (ball journal)...	1	1	1	1
2	T1478	Oil seal	1	1	1	1
3	W680	Circlip	1	1	1	1
4	T1367	Layshaft bush	1	1	-	-
5	T912	Peg	1	1	-	-
6	T981	Blanking disc	1	1	-	-
7	T1606	Layshaft bearing	-	-	1	1
8	T1607	Thrust washer	-	-	1	1
9	T1403	MAINSHAFT HIGH GEAR (26T)	1	1	1	1
10	T1405	High gear bush	1	1	1	1
11	T1406	MAINSHAFT c/w THIRD AND LOW GEARS	1	1	1	1
12	T1391	Clutch rod bush	1	1	1	1
13	T1410	Mainshaft second gear (23T)	1	1	1	1
14	T1411	Mainshaft distance piece	1	1	1	1
15	T1479	Layshaft c/w second and high gears	1	1	-	-
15	T1615	Layshaft c/w second and high gears	-	-	1	1
16	T1413	Layshaft third gear (23T)...	1	1	1	1
17	T1414	LAYSHAFT LOW GEAR (32T)	1	1	1	1
18	T1393	Low gear bush	1	1	1	1
19	T1426	Pawl retaining disc	1	1	1	1
20	T1471	Camplate index plunger	1	1	1	1
21	T373	Index plunger spring	1	1	1	1
22	T1457	Selector fork spindle	1	1	1	1
23	T1480	Mainshaft selector fork	1	1	1	1
24	T1481	Layshaft selector fork	1	1	1	1
25	T1458	Gear selector camplate	1	1	1	1
26	T1418	Camplate spindle	1	1	1	1
27	$\frac{1}{8}$ in. x $\frac{3}{4}$ in.	Split pin	1	1	1	1
28	T1416	Gear indicator pointer	1	1	1	1
29	H688	Screw ($\frac{7}{16}$ in. U.H.)	1	1	1	1
30	T1448	Inner cover	1	1	1	1
31	T1417	Gear indicator plate	1	1	1	1
32	D208-5	Indicator plate rivet	2	2	2	2
33	T1440	Hollow dowel	2	2	2	2
34	T1157	Kickstarter stop plate	1	1	1	1
35	T1390	Stop plate and anchor screw	1	1	1	1
36	T1445	KICKSTARTER SPINDLE	1	1	1	1
37	T1431	Kickstarter pawl	1	1	1	1
38	T1282	Plunger	1	1	1	1
39	T1161	Plunger spring	1	1	1	1
40	T1446	Floating bush	1	1	1	1
41	T1469	Mainshaft bearing (ball journal)	1	1	1	1
42	T280	Circlip	1	1	1	1
43	T732	Tab washer	1	1	1	1
44	E2419	Mainshaft nut	1	1	1	1
45	T1464	Distance piece	1	1	1	1
46	T1441	Kickstarter return spring	1	1	1	1
47	T1422	Return spring plate	1	1	1	1
48	E3204	Screw (1 in. U.H.)	2	2	2	2

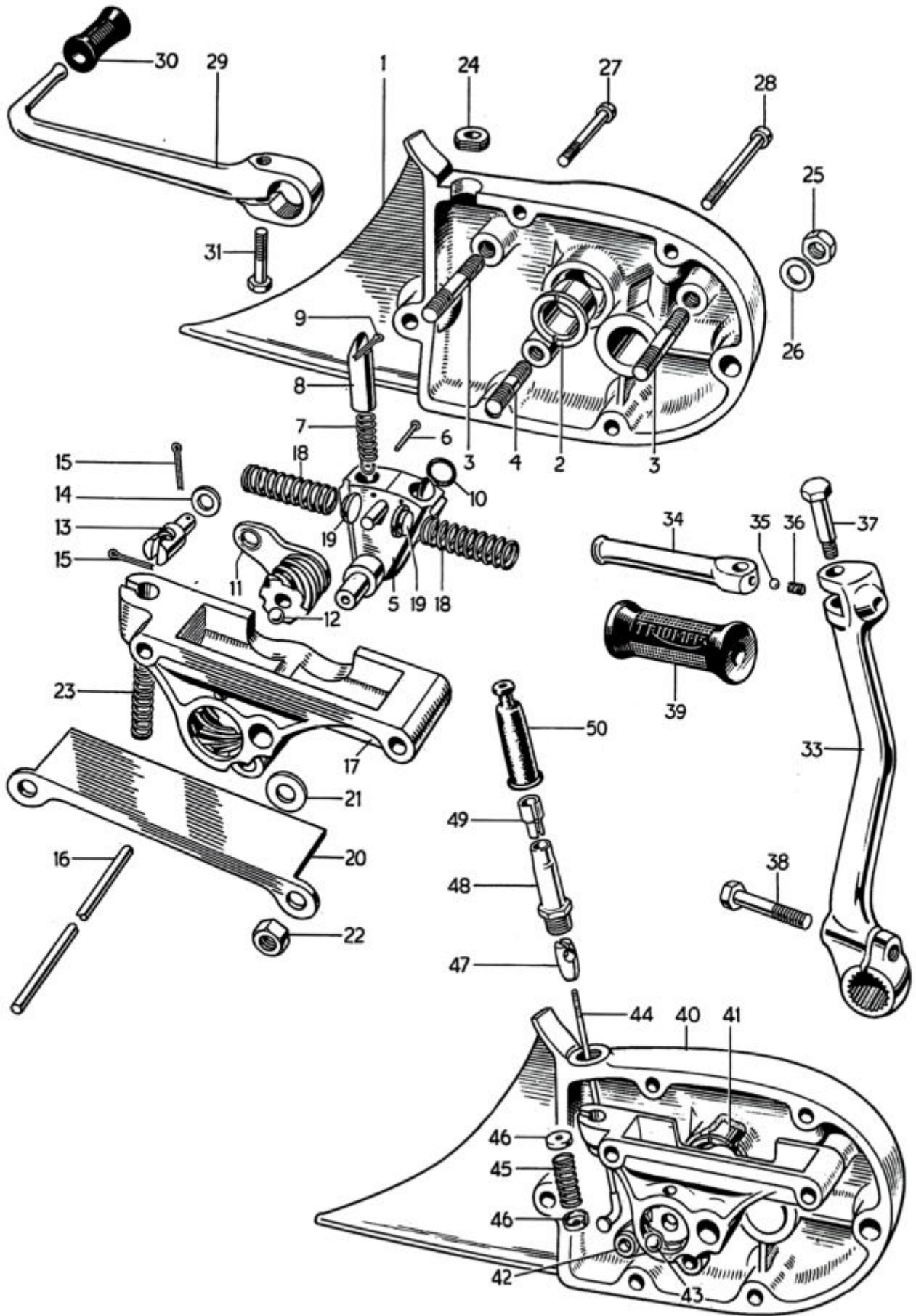

Fig. 7. GEARBOX OUTER COVER AND LEVERS.

GEARBOX OUTER COVER AND LEVERS

								3TA	5TA	T100A	T100SS
1	T1450	GEARBOX OUTER COVER	1	1	1	-
2	T1395	Gearchange spindle bush	1	1	1	-
3	T1388	Stud (1 $\frac{7}{8}$ in. O.A.)	2	2	2	2
4	E1987	Stud (1 $\frac{1}{2}$ in. O.A.)	1	1	1	1
5	T1483	GEARCHANGE QUADRANT	1	1	1	1
6	T1474	Spring retaining pin	2	2	2	2
7	T1436	Plunger spring	2	2	2	2
8	T1396	Selector plunger	2	2	2	2
9	$\frac{5}{64}$ in. x $\frac{5}{8}$ in.	Split pin	2	2	2	2
10	E3309	Sealing ring	1	1	1	1
11	T1459	CLUTCH LEVER AND WORM	1	1	1	-
12	S70-7	Steel ball ($\frac{7}{32}$ in. diam.)	1	1	1	-
13	T1462	Cable abutment	1	1	1	-
14	E3302	Plain washer	1	1	1	-
15	$\frac{1}{8}$ x $\frac{1}{2}$ in.	Split pin	2	2	2	2
16	T1456	Clutch operating rod	1	1	-	-
16	T1574	Clutch operating rod	-	-	1	1
17	T1385	Return spring housing	1	1	1	1
18	T1432	Return spring	2	2	2	2
19	T1433	Thrust button	2	2	2	2
20	T1394	Cover	1	1	1	1
21	S25-1	Plain washer	1	1	1	1
22	W103	Nut	3	3	3	3
23	T1465	Clutch cable spring	1	1	1	-
24	E3475	Cable grommet	1	1	1	-
25	S1-51	Nut	2	2	2	2
26	S25-3	Plain washer	2	2	2	2
27	T1401	Screw (2 $\frac{3}{8}$ in. U.H.)	2	2	2	2
28	T1402	Screw (2 $\frac{3}{8}$ in. U.H.)	2	2	2	2
29	T1435	Gearchange lever	1	1	1	1
30	T449	Pedal rubber	1	1	1	1
31	W932	Bolt (1 in. U.H.)	1	1	1	1
32	T1485	KICKSTARTER LEVER COMPLETE	1	1	1	1
33	T1438	Kickstarter crank	1	1	1	1
34	T1272	Kickstarter pedal	1	1	1	1
35	S70-3	Steel ball	1	1	1	1
36	T1167	Index spring	1	1	1	1
37	T1273	Pivot bolt	1	1	1	1
38	T1439	Clamp bolt (1 $\frac{7}{8}$ in. U.H.)	1	1	1	1
39	F1814	Pedal rubber	1	1	1	1
		From engine No. H25252 use									
40	T1637	GEARBOX OUTER COVER	1	1	-	1
41	T1395	Gearchange spindle bush	1	1	-	1
42	T1638	CLUTCH LEVER AND WORM	1	1	-	1
43	S70-7	Steel ball ($\frac{7}{32}$ in. diam.)	1	1	-	1
44	T1640	Spoke	1	1	-	1
45	T1641	Spring	1	1	-	1
46	T1642	Cup	2	2	-	2
47	T1643	Connector	1	1	-	1
48	T1644	Abutment	1	1	-	1
49	T1645	Adaptor	1	1	-	1
50	T1646	Rubber cover	1	1	-	1

ASSEMBLY REF. No. 1

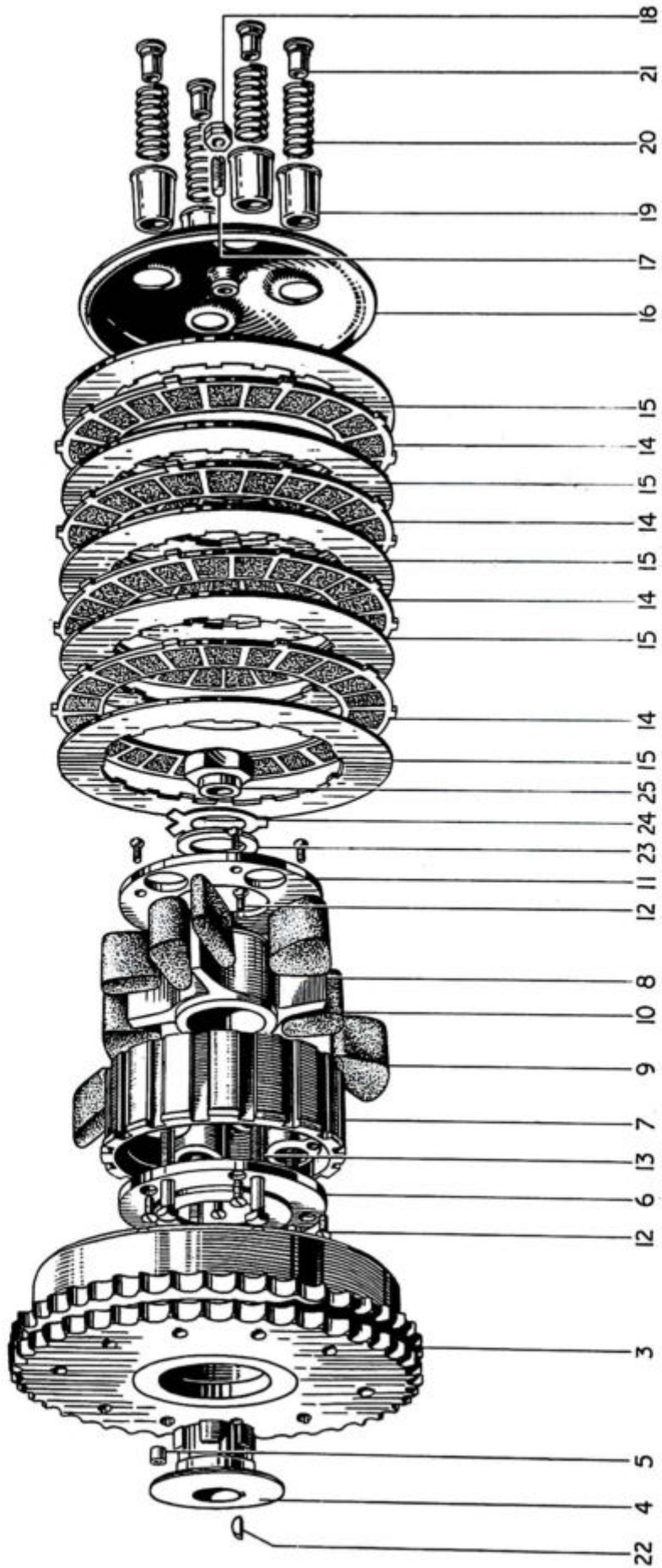

Fig. 8. CLUTCH

CLUTCH

									3TA	5TA	T100A	T100SS
1	T1486	CLUTCH COMPLETE	1	-	-	-
2	T1573	CLUTCH COMPLETE	-	1	1	1
3	T1442	Sprocket and housing	1	-	-	-
3	T1570	Sprocket and housing	-	1	1	1
4	T1386	Hub	1	1	1	1
5	T394	Roller	20	20	20	20
6	T1039	Inner plate	1	1	1	1
7	T1037	Centre (Shock absorber body)	1	-	-	-
7	T1038	Centre (Shock absorber body)	-	1	1	1
8	T1041	Shock absorber spider	1	1	1	1
9	T1472	Drive rubber (large)	4	4	4	4
10	T1473	Rebound rubber (small)	4	4	4	4
11	T1044	Outer plate	1	1	1	1
12	T1040	Countersunk screw (0.417 in. U.H.)	8	8	8	8
13	T423	Screwed pin (1 $\frac{1}{2}$ in. U.H.)	4	-	-	-
13	T423A	Screwed pin (1 $\frac{3}{4}$ in. U.H.)	-	4	4	4
14	T1362	Driving plate (bonded)	4	5	5	5
15	T1363	Driven plate (plain)	5	6	6	6
16	T1466	Pressure plate	1	1	1	1
17	T1256	Adjuster pin	1	1	1	1
18	GS662	Nut	1	1	1	1
19	T425	Spring cup	4	-	-	-
19	T998	Spring cup	-	4	4	4
20	T429	Spring	4	-	-	-
20	T999	Spring	-	4	4	4
21	T427	Brass nut	4	4	4	4
22	S66-1	Key	1	1	1	1
23	T1045	Cupped washer	1	1	1	1
24	T1046	Tab washer	1	1	1	1
25	T1047	Nut	1	1	1	1

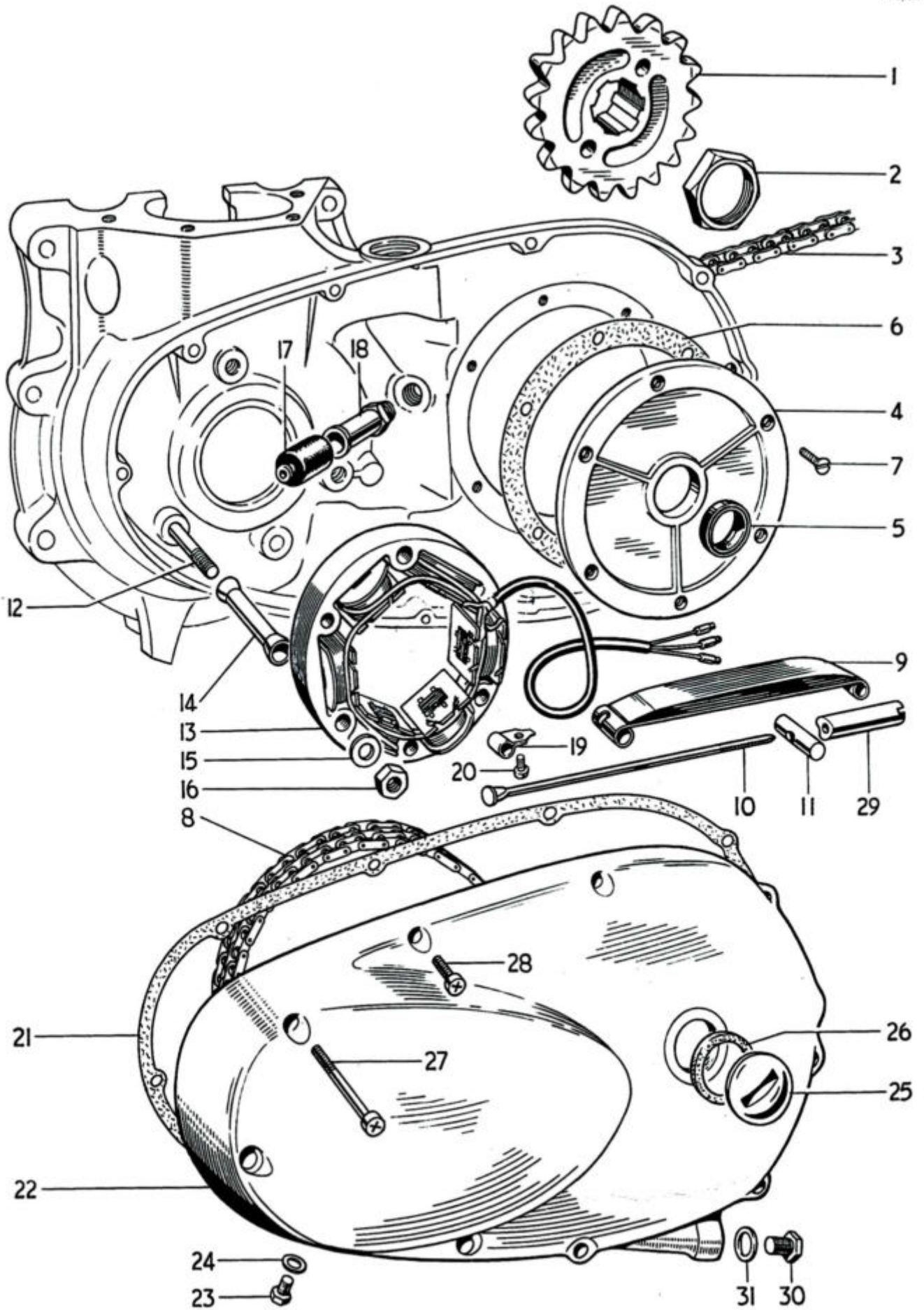

Fig. 9. CHAINCASE AND CHAINS.

Ref. No.	Part No.	DESCRIPTION	QUANTITY			
			3TA	5TA	T100A	T100SS
1	T1476	Gearbox sprocket (18 teeth)	1	-	-	1
1	T1558	Gearbox sprocket (17 teeth)	A	A	A	A
1	T1569	Gearbox sprocket (20 teeth)	A	A	A	A
1	T1476/19	Gearbox sprocket (19 teeth)	-	1	1	A
2	T1434	Gearbox sprocket nut	1	1	1	1
3	D304	Rear chain, $\frac{5}{8}$ in. x $\frac{3}{8}$ in. x 100L	1	-	-	-
3	D310	Rear chain, $\frac{5}{8}$ in. x $\frac{3}{8}$ in. x 101L	-	1	1	1
4	E3789	Cover plate	1	1	1	1
5	E3833	Oil seal	1	1	1	1
6	E3832	Joint washer	1	1	1	1
7	E3821	Countersunk screw ($\frac{7}{16}$ in. U.H.)	6	6	6	6
8	D358	Primary chain, $\frac{3}{8}$ in. Duplex 78L	1	1	1	1
9	E4149	Chain tensioner blade	1	1	1	1
10	E4152	Tie rod	1	1	1	1
11	E4148	Trunnion	1	1	1	1
12	†E3811	Stud ($3\frac{1}{16}$ in. O.A.)	3	3	3	3
13	†468973	Stator	1	1	1	-
13	47164	Stator, RM19 (After engine No. H25252)	1	1	-	1
14	E3810	Distance piece	3	3	3	3
15	S25-3	Plain washer	3	3	3	3
16	S1-51	Nut	3	3	3	3
17	E4144	Rubber grommet	1	1	1	1
18	E4143	Sleeve nut	1	1	1	1
19	E1509	Clip	1	1	1	1
20	T361	Bolt ($\frac{1}{4}$ in. U.H.)	1	1	1	1
21	E4156	Joint washer	1	1	1	1
22	E4122	Chaincase	1	1	1	1
23	DS57	Drain and level plug	2	1	1	1
24	WE170	Fibre washer	2	1	1	1
25	E732	Filler plug	1	1	1	1
26	NE507	Fibre washer	1	1	1	1
27	E3802	Screw ($2\frac{3}{4}$ in. U.H.)	3	3	3	3
28	E3668	Screw ($1\frac{1}{8}$ in. U.H.)	7	7	7	7
29	E4153	Adjuster sleeve nut	1	1	1	1
30	E4154	Drain plug	1	1	1	1
31	GS761	Fibre washer	1	1	1	1
†Up to engine No. H22430 use						
12	E4145	Stud ($3\frac{1}{16}$ in. O.A.)	-	-	3	-
13	47149	Stator	-	-	1	-

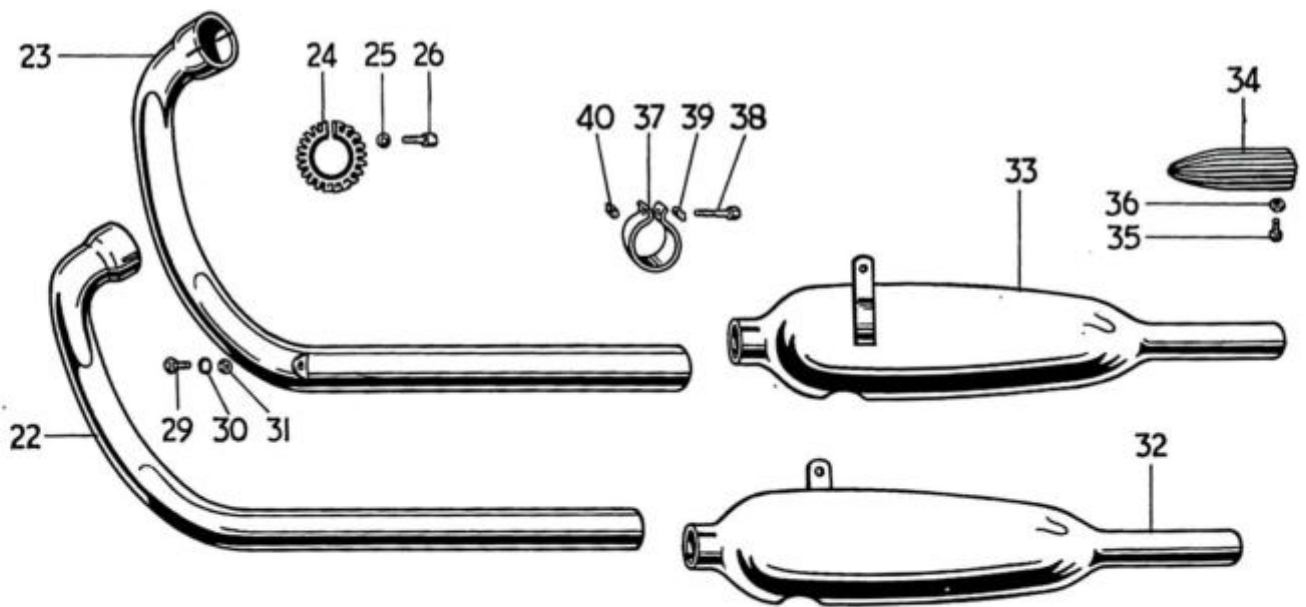
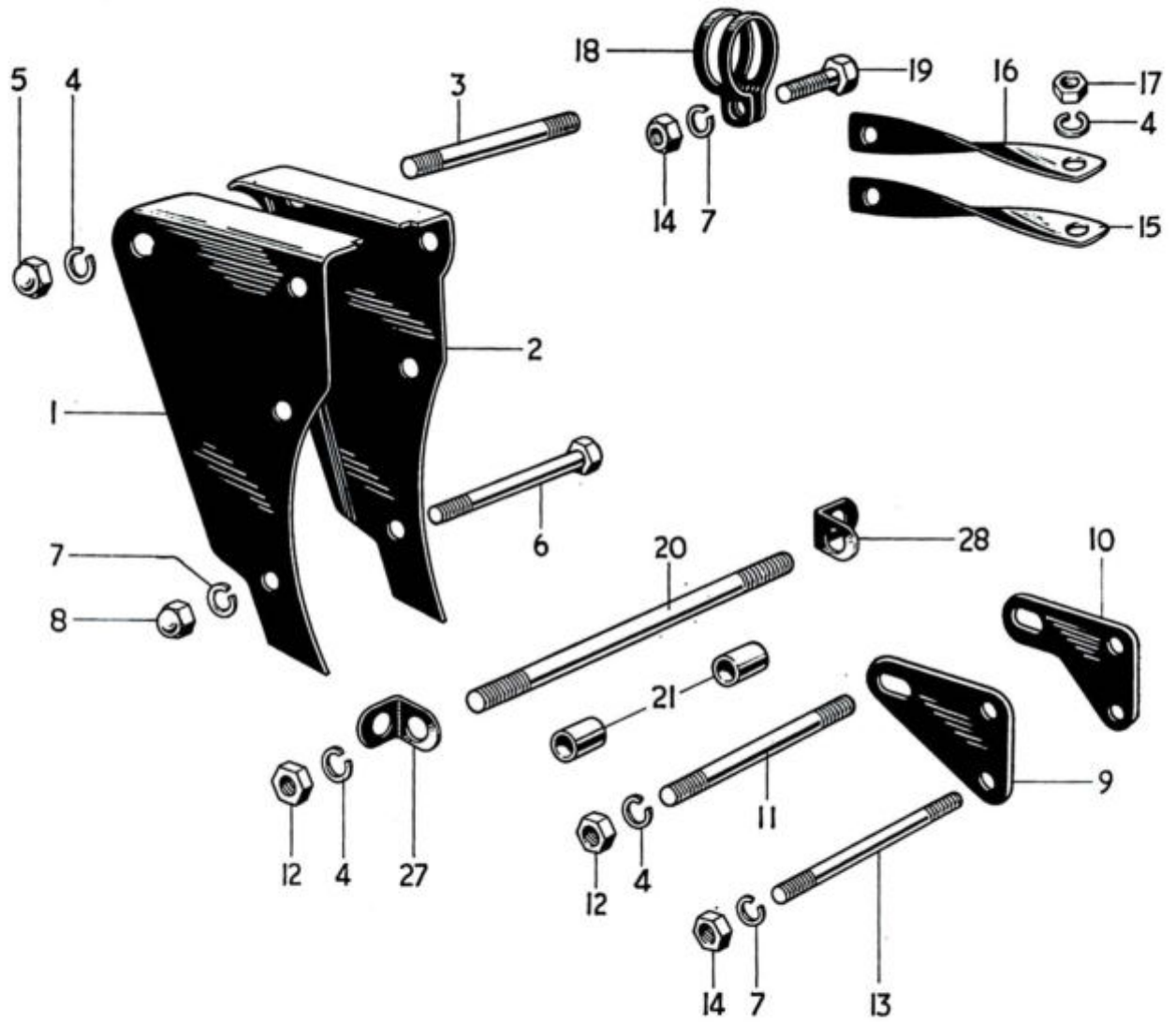

Fig. 10 ENGINE FITTINGS AND EXHAUST SYSTEM.

ENGINE FITTINGS AND EXHAUST SYSTEM

									3TA	5TA	T100A
1	F4275	Left front engine plate	1	1	1
2	F4276	Right front engine plate	1	1	1
3	F2825	Stud (3¼ in. O.A.)	1	1	1
4	S26-1	Spring washer	8	8	8
5	E1435	Domed nut	2	2	2
6	E3937	Bolt (2½ in. U.H.)	3	3	3
7	S26-3	Spring washer	8	8	8
8	E3949	Domed nut	3	3	3
9	F4229	Left rear engine plate	1	1	1
10	F4230	Right rear engine plate	1	1	1
11	F3665	Stud (4¼ in. O.A.)	1	1	1
12	PO172A	Nut	4	4	4
13	E3695	Stud (4½ in. O.A.)	2	2	2
14	S1-51	Nut	5	5	5
15	E3860	Left torque stay	1	1	1
16	E3861	Right torque stay	1	1	1
17	S1-52	Nut	2	2	2
18	E3862	Torque stay clip	1	1	1
19	DS58	Bolt (¾ in. U.H.)	1	1	1
20	E3812	Stud (7½ in. O.A.)	1	1	1
21	F4197	Distance piece	2	2	2
22	E3992	Left exhaust pipe	1	1	1
23	E3994	Right exhaust pipe	1	1	1
24	E1270	Finned clip	2	2	2
25	E410A	Hemispherical washer	2	2	2
26	E409	Bolt (1 ⅞ in. U.H.)	2	2	2
27	F4707	Left bracket	1	1	1
28	F4283	Right bracket	1	1	1
29	DS57	Bolt (⅞ in. U.H.)	2	2	2
30	E1612	Serrated washer	2	2	2
31	F879	Nut	2	2	2
32	E3935	Left silencer	1	1	-
32	E4157	Left silencer	-	-	1
33	E3936	Right silencer	1	1	-
33	E4158	Right silencer	-	-	1
34	E4155	Silencer mute	A	A	2
35	H689	Screw (¼ in. U.H.)	A	A	2
36	H691	Nut	A	A	2
37	E2271	Clip	2	2	2
38	TE164E	Bolt (1 ⅞ in. U.H.)	2	2	2
39	TE164D	"D" washer	2	2	2
40	TE164C	"D" nut	2	2	2

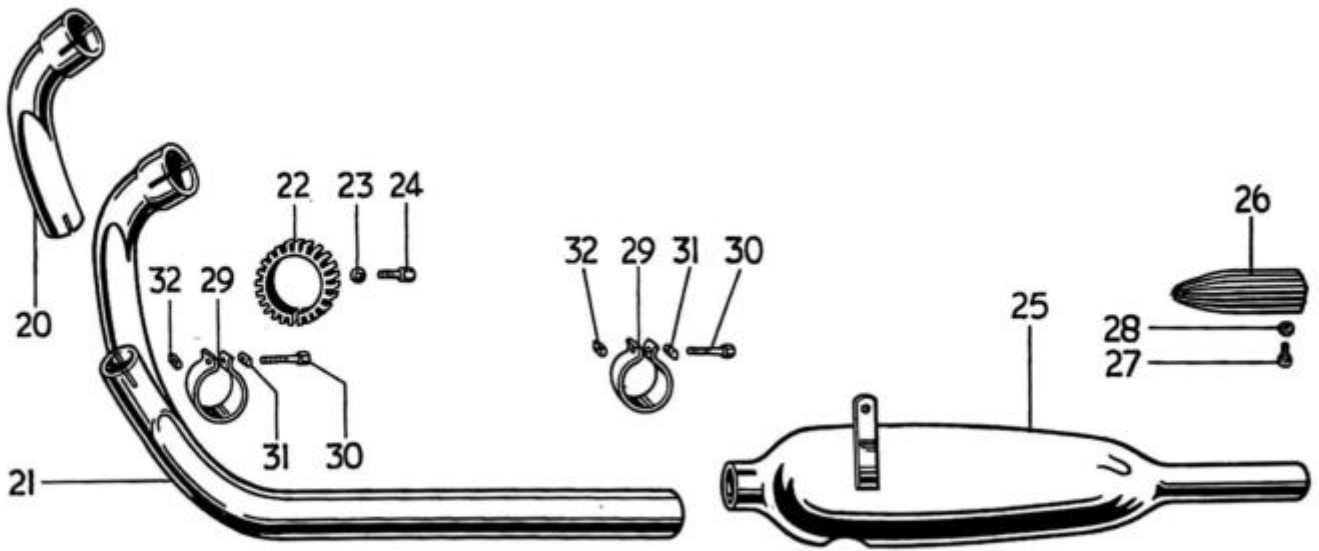
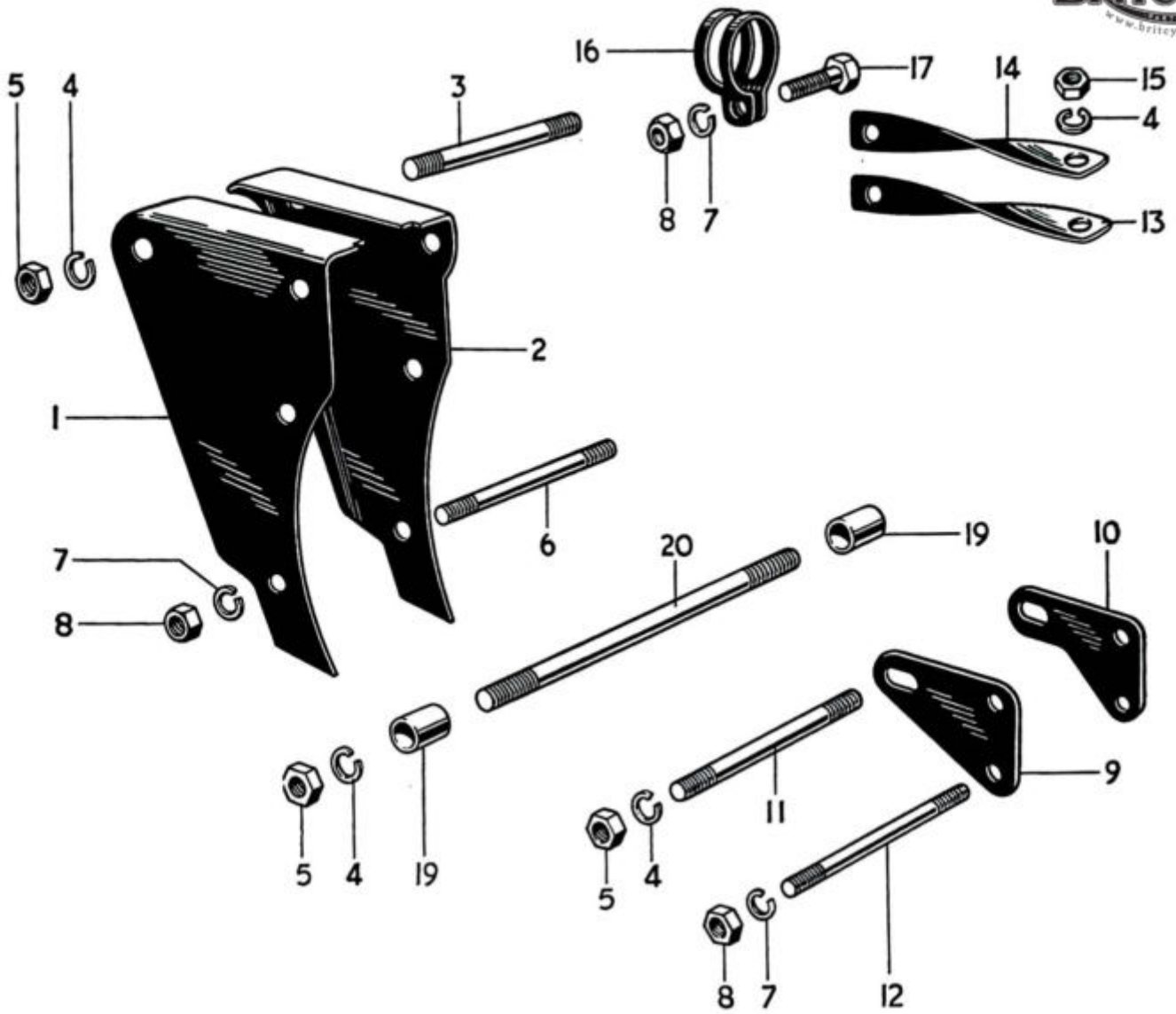

Fig. 11. ENGINE FITTINGS AND 2 INTO 1 EXHAUST SYSTEM

ENGINE FITTINGS AND 2 INTO 1 EXHAUST SYSTEM

									3TA	5TA	T100A	T100SS
1	F4275	Left front engine plate...	1	1	1	1
2	F4276	Right front engine plate	1	1	1	1
3	F2825	Stud (3¼ in. O.A.)	1	1	1	1
4	S26-1	Spring washer	8	8	8	8
5	PO172A	Nut	6	6	6	6
6	E3804	Stud (3 in. O.A.)	3	3	3	3
7	S26-3	Spring washer	10	10	10	10
8	S1-51	Nut	10	10	10	10
9	F4229	Left rear engine plate	1	1	1	1
10	F4230	Right rear engine plate	1	1	1	1
11	F3665	Stud (4¼ in. O.A.)	1	1	1	1
12	E3695	Stud (4⅞ in. O.A.)	2	2	2	2
13	E3860	Left torque stay	1	1	1	1
14	E3861	Right torque stay	1	1	1	1
15	S1-52	Nut	2	2	2	2
16	E3862	Torque stay clip	1	1	1	1
17	DS58	Bolt (¾ in. U.H.)	1	1	1	1
18	E3812	Stud (7½ in. O.A.)	1	1	1	1
19	F4197	Distance piece	2	2	2	2
20	E4467	Left exhaust pipe	1	1	1	1
21	E4468	Right exhaust pipe	1	1	1	1
22	E1270	Finned clip	2	2	2	2
23	E410A	Hemispherical washer	2	2	2	2
24	E409	Bolt (1½ in. U.H.)	2	2	2	2
25	E4415	Silencer	1	1	1	1
26	E4155	Silencer mute	A	A	A	A
27	H689	Screw (¼ in. U.H.)	A	A	A	A
28	H691	Nut	A	A	A	A
29	E2271	Clip	2	2	2	2
30	TE164E	Bolt (½ in. U.H.)	2	2	2	2
31	TE164D	"D" washer	2	2	2	2
32	TE164C	"D" nut	2	2	2	2

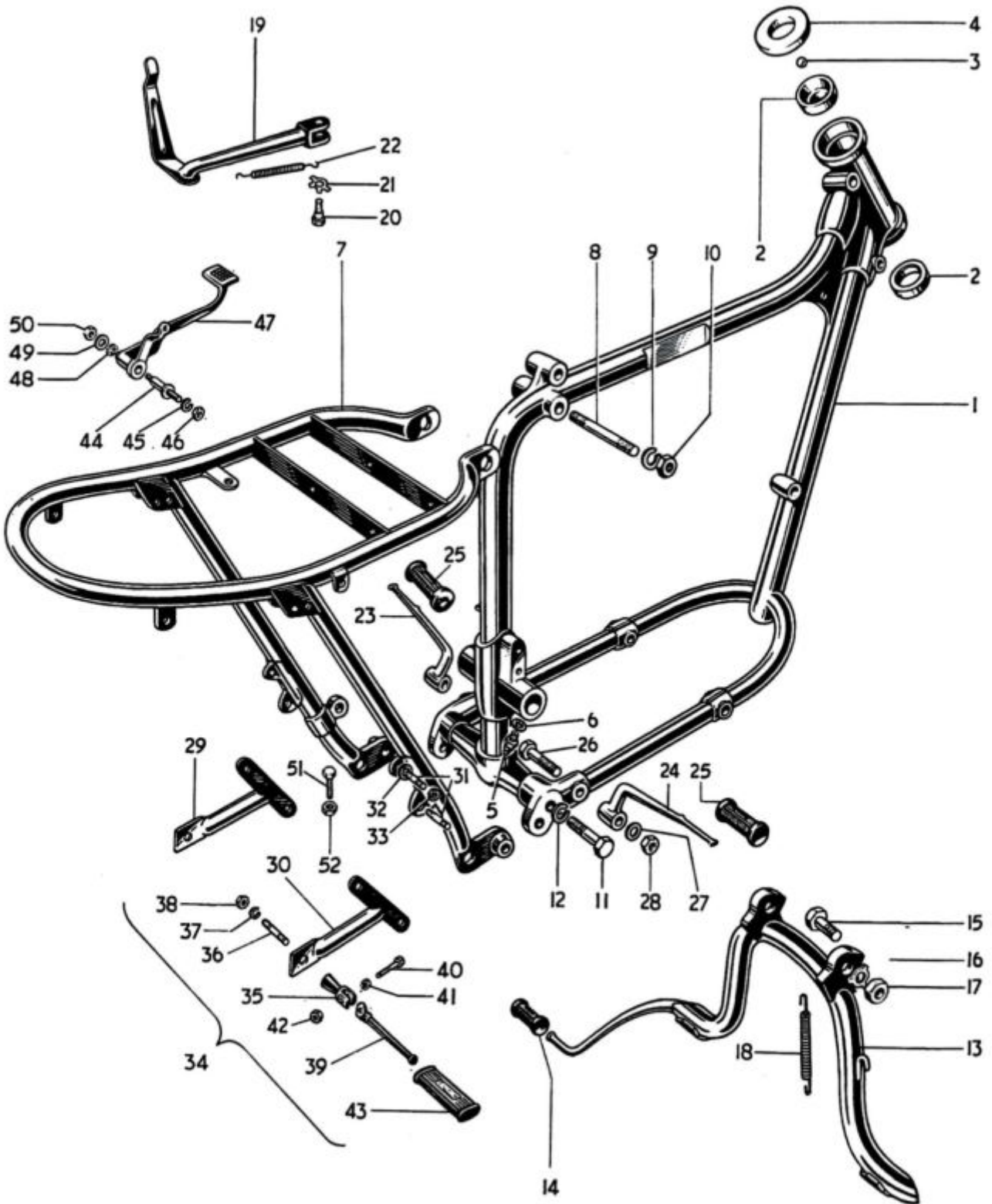

Fig. 12. FRAME

Ref. No.	Part No.	DESCRIPTION	3TA	5TA	T100A	T100SS
FRAME						
1	F4849	Front frame	1	1	1	1
2	H1130	Steering race cup	2	2	2	2
3	S70-4	Steel ball ($\frac{3}{8}$ in. diam.)	48	48	48	48
4	H1140	Top cone and dust cover... ..	1	1	1	1
5	KW194	Grease nipple	1	1	1	1
6	WE170	Fibre washer	1	1	1	1
7	F4158	Rear frame	1	1	1	-
7	F5146	Rear frame	-	-	-	1
8	F2842	Stud ($3\frac{7}{8}$ in. O.A.)	1	1	1	1
9	S26-1	Spring washer	2	2	2	2
10	S1-52	Nut	2	2	2	2
11	F3780	Bolt ($1\frac{1}{8}$ in. U.H.)	2	2	2	2
12	PCW73A	Spring washer	2	2	2	2
13	F4402	Centre stand	1	1	1	-
13	F5153	Centre stand	-	-	-	1
14	T449	Pedal rubber	1	1	1	1
15	F3619	Pivot bolt ($1\frac{1}{8}$ in. U.H.)	2	2	2	2
16	F4484	Tab washer	2	2	2	2
17	F2725	Nut	2	2	2	2
18	F3617	Return spring	1	1	1	1
19	F4388	Prop stand	1	1	1	1
20	F3097	Pivot bolt	1	1	1	1
21	F3096	Tab washer	1	1	1	1
22	F2610	Return spring	1	1	1	1
23	F4214	Left footrest	1	1	1	1
24	F4215	Right footrest	1	1	1	1
25	NF704	Pedal rubber	2	2	2	2
26	F4369	Bolt ($2\frac{1}{2}$ in. U.H.)	2	2	2	2
27	F4370	Plain washer	2	2	2	2
28	DS47	Nut	2	2	2	2
29	F5087	Left pillion footrest support	1	1	1	1
30	F5088	Right pillion footrest support	1	1	1	1
31	E1396	Stud ($\frac{1}{2}$ in. O.A.)	4	4	4	4
32	S26-3	Spring washer	4	4	4	4
33	S1-51	Nut	4	4	4	4
34	F4327	PILLION FOOTREST	2	2	2	2
35	F2268	Footrest hanger	2	2	2	2
36	F4309	Stud ($1\frac{3}{8}$ in. O.A.)	2	2	2	2
37	S26-1	Spring washer	2	2	2	2
38	PO172A	Nut	2	2	2	2
39	F1694	Pedal	2	2	2	2
40	F2271	Pivot bolt	2	2	2	2
41	F2277	Spring washer	2	2	2	2
42	S1-51	Nut	2	2	2	2
43	F1695	Pedal rubber	2	2	2	2
44	F4284	Brake pedal spindle	1	1	1	1
45	SCZ45	Spring washer	1	1	1	1
46	DS48	Nut	1	1	1	1
47	F4314	Brake pedal	1	1	1	1
48	S26-16	Spring washer	1	1	1	1
49	S25-2	Plain washer	1	1	1	1
50	S1-52	Nut	1	1	1	1
51	F1149	Pedal stop screw ($\frac{1}{2}$ in. U.H.)	1	1	1	1
52	F879	Nut	1	1	1	1

For 3TA and 5TA steering stops see Page 69.

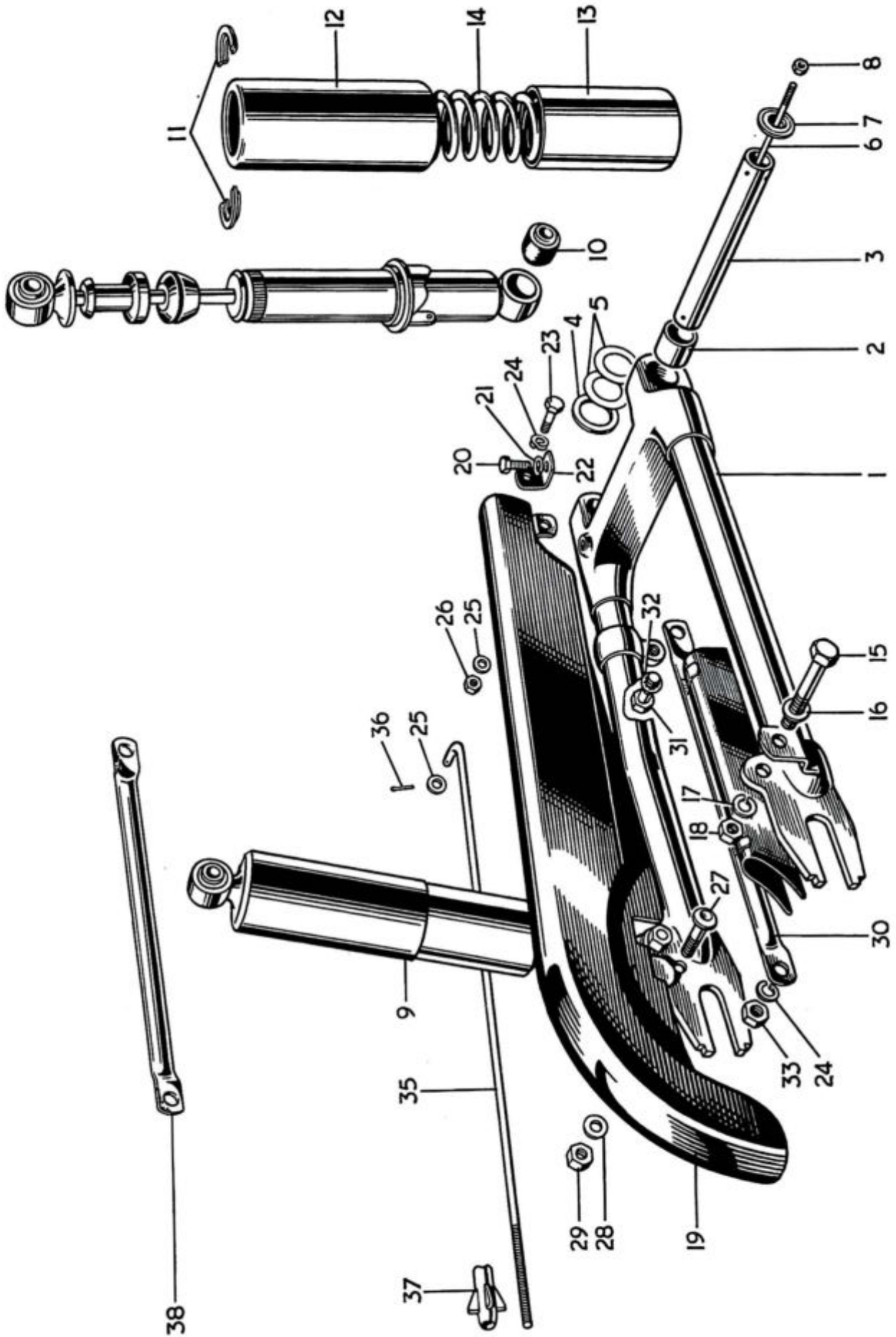

Fig. 13. SWINGING FORK, SUSPENSION UNITS AND CHAINGUARD.

SWINGING FORK, SUSPENSION UNITS & CHAINGUARD			3TA	5TA	T100A	T100SS
1	F4190	SWINGING FORK	...	1	1	1
2	F4076	Pivot bush	...	2	2	2
3	F4195	Spindle	...	1	1	1
4	F4078	Spacing washer	...	1	1	1
5	F4385	Shim 0.003 in.	...		as required	
5	F4386	Shim 0.005 in.	...		as required	
6	F3797	Retainer rod	...	1	1	1
7	F4196	Cap	...	2	2	2
8	F3799	Nut	...	2	2	2
9	64053946	SUSPENSION UNIT	...	2	-	2
9	64054200	SUSPENSION UNIT	...	-	2	-
10	9054/316A	Bonded bush	...	4	4	4
11	9054/171	Spring retainer	...	4	4	4
12	9054/151	Outer dirt shield	...	2	2	2
13	9054/47	Inner dirt shield	...	2	2	2
14	64539963	Spring, 130 lbs. Red/Orange	...	2	2	2
14	9054/277	Spring, 110 lbs. Red/Red	...	A	A	A
14	SA253/5	Spring, 145 lbs. Blue/Yellow	...	A	A	A
15	E2113	Unit fixing bolt (1 $\frac{1}{8}$ in. U.H.)	...	4	4	4
16	F2184	Plain washer	...	2	2	2
17	S26-1	Spring washer	...	4	4	4
18	PO172A	Nut	...	4	4	4
19	F4198	Upper chainguard	...	1	1	1
20	DS57	Bolt ($\frac{7}{8}$ in. U.H.)	...	1	1	1
21	S26-2	Spring washer	...	1	1	1
22	F4134	Front bracket	...	1	1	1
23	F4135	Pivot bolt	...	1	1	1
24	F2277	Spring washer	...	1	1	1
25	S25-13	Plain washer	...	2	2	2
26	F879	Nut	...	1	1	1
27	F4136	Stepped bolt	...	1	1	1
28	S25-3	Plain washer	...	1	1	1
29	S1-51	Nut	...	1	1	1
30	F4199	Lower chainguard	...	1	1	-
31	W840	Bolt ($\frac{7}{8}$ in. U.H.)	...	1	1	1
32	E2288	Serrated washer	...	1	1	1
33	DS47	Nut	...	1	1	1
34	PCW73A	Spring washer	...	1	1	1
35	F3597	Brake operating rod	...	1	1	1
36	$\frac{1}{4}$ in. x $\frac{3}{8}$ in.	Split pin	...	1	1	1
37	F4585	Adjuster nut	...	1	1	1
38	F4201	Brake torque stay	...	-	-	1

TELESCOPIC FRONT FORK

									3TA	5TA	T100A
1	H1174	FORK ASSEMBLY	1	1	1
2	H1112	Middle lug and stem...	1	1	1
3	H1110	Bottom cone	1	1	1
4	H941	Pinch bolt (2¼ in. U.H.)	2	2	2
5	S25-2	Plain washer	2	2	2
6	E2412	Nut	2	2	2
7	H1141	Fork stem sleeve nut	1	1	1
8	H1108	Top lug	1	1	1
9	F1760	Pinch bolt (1⅞ in. U.H.)	1	1	1
10	H379	Seated nut	1	1	1
11	H1145	Left nacelle cover	1	1	1
12	H1146	Right nacelle cover	1	1	1
13	H420	Sponge rubber washer	2	2	2
14	H1123	STANCHION c/w BEARING	2	2	2
15	H443	Lower bearing	2	2	2
16	H1058	Bearing nut	2	2	2
17	H519A	Oil filler plug (⅜ in. U.H.)	2	2	2
18	H1117	LEFT BOTTOM MEMBER c/w CAP	1	1	1
19	H1118	RIGHT BOTTOM MEMBER c/w CAP	1	1	1
20	H1053	Spindle cap	2	2	2
21	S26-3	Spring washer	4	4	4
22	H1070	Cap bolt (1⅞ in. U.H.)	4	4	4
23	H1071	Drain plug	2	2	2
24	H430	Fibre washer	4	4	4
25	H1063	Flanged bolt (⅜ in. U.H.)	2	2	2
26	H1062	Aluminium washer	2	2	2
27	H1124	RESTRICTOR ROD ASSEMBLY	2	2	2
28	H1061	Restrictor rod	2	2	2
29	H1060	Plain washer	2	2	2
30	H1125	Guide tube	2	2	2
31	H1127	Main spring. Yellow	2	2	2
32	H1064	CAP NUT ASSEMBLY	2	2	2
33	H1051	Guide tube	2	2	2
34	H1065	Cap nut	2	2	2
35	H1066	Pin	2	2	2
36	H1126	Damping sleeve	2	2	2
37	H441	Top bearing	2	2	2
38	H431	Plain washer	2	2	2
39	H1194	DUST EXCLUDER SLEEVE NUT	2	2	2
40	H1168	Oil seal	2	2	2
41	H1142	Steering damper knob c/w rod	1	1	1
42	H565	Plain washer	1	1	1
43	H408	Adjuster sleeve	1	1	1
44	H409	Locating pin	1	1	1
45	H95	Spring plate	1	1	1
46	H1111	Anchor plate	1	1	1
47	H435	Friction disc	1	1	1
48	H660	Handlebar "U" bolt	2	2	2
49	S25-3	Plain washer	4	4	4
50	E1310	Nut	4	4	4
51	F3468	Bolt (2⅞ in. U.H.)	1	1	1
52	S1-51	Nut	1	1	1

For 3TA and 5TA steering stops see Page 69.

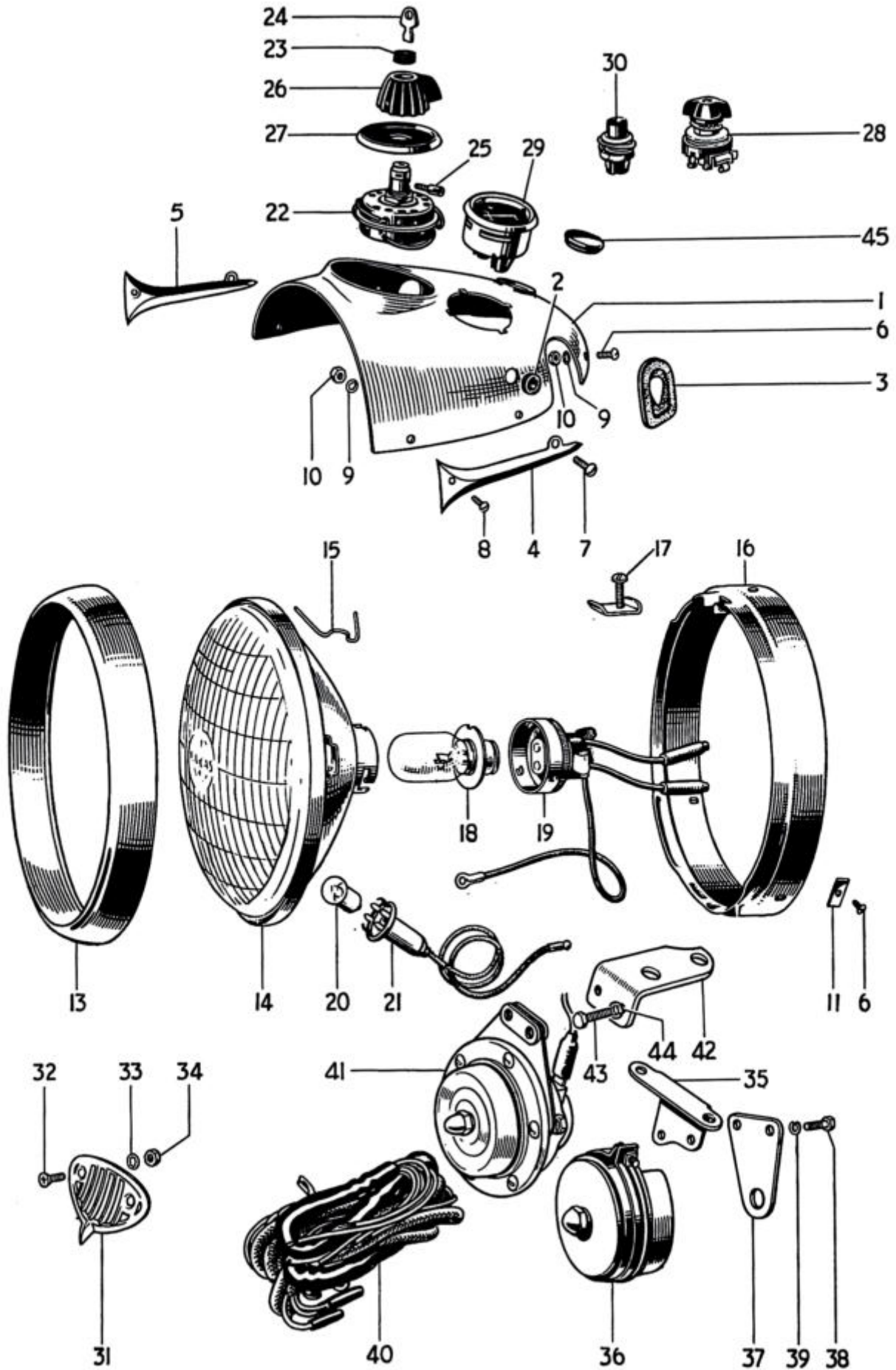

Fig. 15. NACELLE, HEADLAMP AND SWITCHES

NACELLE, HEADLAMP AND SWITCHES

											3TA	5TA	T100A
1	H1144	Nacelle top	1	1	-
1	†H1298	Nacelle top	-	-	1
2	H961	Rubber grommet	3	3	3
3	H669	Rubber grommet	2	2	2
4	H877	Left motif	1	1	1
5	H878	Right motif	1	1	1
6	H689	Screw (1/4 in. U.H.)	4	4	4
7	H687	Screw (3/8 in. U.H.)	2	2	2
8	H688	Screw (7/8 in. U.H.)	2	2	2
9	E2880	Serrated washer	4	4	4
10	H691	Nut	4	4	4
11	H690	Nut	2	2	2
12	51860	HEADLAMP	1	1	1
13	553248	Rim	1	1	1
14	516812	Light unit	1	1	1
15	504665	Fixing wire	6	6	6
16	553267	Fixing ring	1	1	1
17	534296	Screw and plate	1	1	1
18	373	Bulb (30/24 W. L.H. Dipping. Pre-focus)	1	1	1
19	554602	Adaptor	1	1	1
20	988	Bulb (3W. M.C.C.)	1	1	1
21	554710	Pilot bulbholder	1	1	1
22	31443	LIGHTING AND IGNITION SWITCH. P.R.S.8	1	1	-
23	318323	Grommet	1	1	-
24	318341	Key	1	1	-
25	319333	Screw	1	1	-
26	318346	Knob	1	1	-
27	318343	Index plate	1	1	-
28	†31784	Lighting switch S.A. 41	-	-	1
29	36189	Ammeter, B.M.4	1	1	1
30	31071	Cut-out button, S.S.5	1	1	1
31	H992	Horn grille	1	1	1
32	H993	Screw (0.540 in. U.H.)	2	2	2
33	GS299	Serrated washer	2	2	2
34	F3799	Nut	2	2	2
35	*H1172	Horn bracket	1	1	1
36	*70048	Horn (Type HF1441)	1	1	1
37	*701851	Fixing plate	2	2	2
38	*142689	Screw	2	2	2
39	*185051	Spring washer	2	2	2
40	54094333	Wiring harness	1	1	-
40	†54094161	Wiring harness	-	-	1

†After engine No. H22430 for T100A use 5TA electrical equipment.

*After engine No. H25252 use the following:—

41	70163	Horn Type 8H	1	1	-
42	H1420	Horn bracket	1	1	-
43	F4771	Bolt (1/2 in. U.H.)	2	2	-
44	GS299	Serrated washer	2	2	-
45	H1421	Rubber grommet	1	1	-

FORK ASSEMBLY REF. N° 1

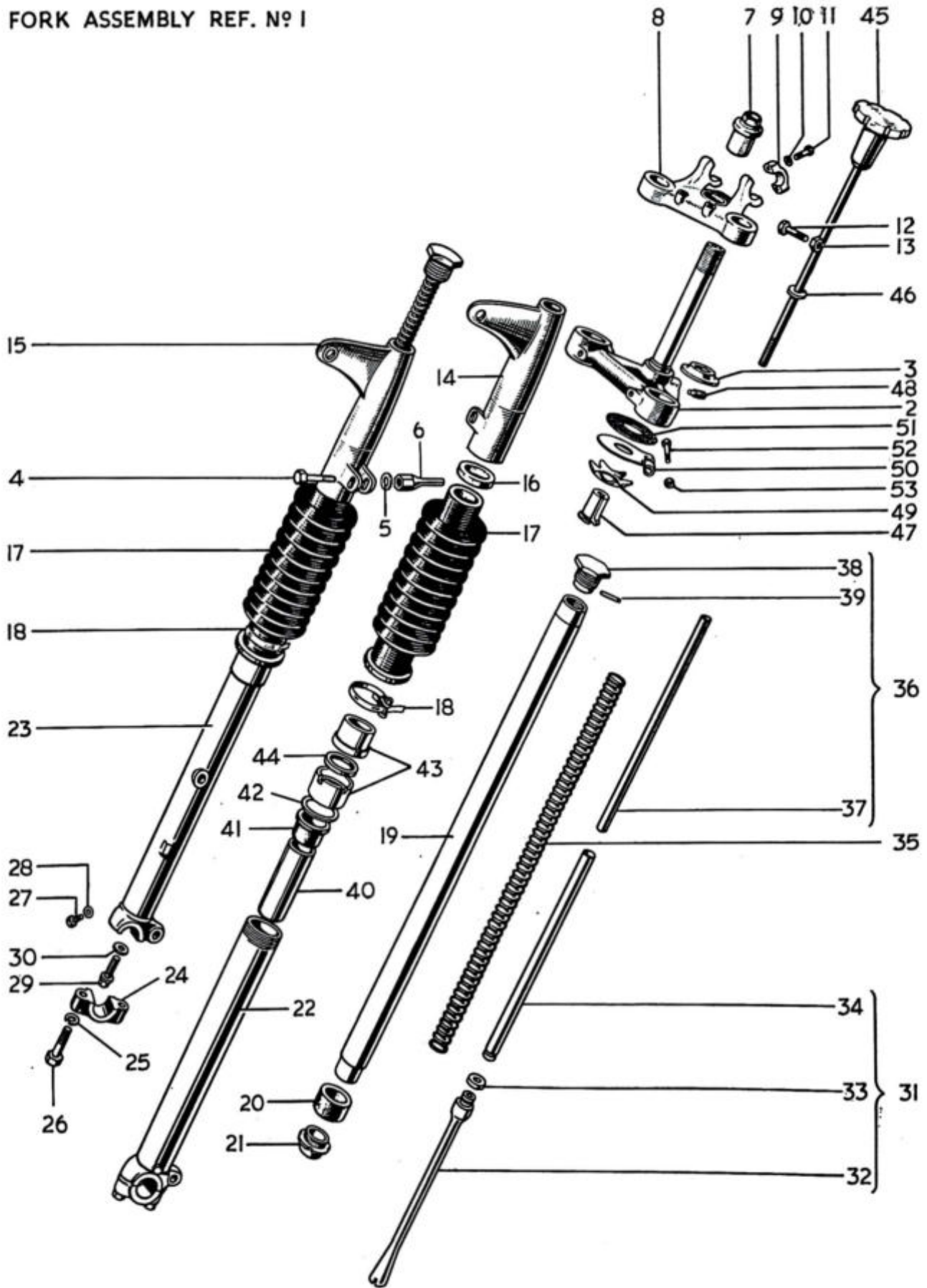

Fig. 16 TELESCOPIC FRONT FORK T100SS

Ref No.	Part No.	DESCRIPTION	QUANTITY
TELESCOPIC FRONT FORK			
			T100SS
1	H1337	FORK ASSEMBLY	1
2	H1328	Middle lug and stem...	1
3	H1110	Bottom cone	1
4	H941	Pinch bolt (2½ in. U.H.)	2
5	S25-2	Plain washer	2
6	H1335	Nut (2¼ in. O.A.) used with 3½ gallon tank	2
6	H1329	Nut (1 1/8 in. O.A.) used with 2½ gallon tank	A
7	H405	Fork stem sleeve nut	1
8	H1287	TOP LUG c/w CAPS	1
9	H506	Handlebar cap	2
10	S25-3	Plain washer	4
11	H1340	Bolt (1 1/8 in. U.H.)	4
12	F1760	Pinch bolt (1 1/8 in. U.H.)	1
13	H379	Seated nut	1
14	H963	Left cover	1
15	H964	Right cover	1
16	H420	Sponge rubber washer	2
17	H962	Telescopic gaiter	2
18	D340	Clip	2
19	H1299	STANCHION c/w BEARING	2
20	H443	Lower bearing	2
21	H1058	Bearing nut	2
22	H1117	LEFT BOTTOM MEMBER c/w CAP	1
23	H1118	RIGHT BOTTOM MEMBER c/w CAP	2
24	H1053	Spindle cap	2
25	S26-3	Spring washer	4
26	H1070	Bolt (1 7/8 in. U.H.)	4
27	H1071	Drain plug	2
28	H430	Fibre washer	2
29	H1063	Flanged bolt (3/8 in. U.H.)	2
30	H1062	Aluminium washer	2
31	H1124	RESTRICTOR ROD ASSEMBLY	2
32	H1061	Restrictor rod	2
33	H1060	Plain washer	2
34	H1125	Guide tube	2
35	H1300	Main spring (Black/White)	2
36	H1064A	CAP NUT ASSEMBLY	2
37	H1051	Guide tube	2
38	H1065A	Cap nut	2
39	H1066	Pin	2
40	H1126	Damping sleeve	2
41	H441	Top bearing	2
42	H431	Plain washer	2
43	H1194	DUST EXCLUDER SLEEVE NUT	2
44	H1168	Oil seal	2
45	H1142	Steering damper rod	1
46	H565	Plain washer	1
47	H408	Adjuster sleeve	1
48	H1286	Locating pin	1
49	H95	Spring plate	1
50	H1111A	Anchor plate	1
51	H435	Friction disc	1
52	F3468	Bolt (2¼ in. U.H.)	1
53	S1-51	Nut	1

ASSEMBLY REF. No. 1

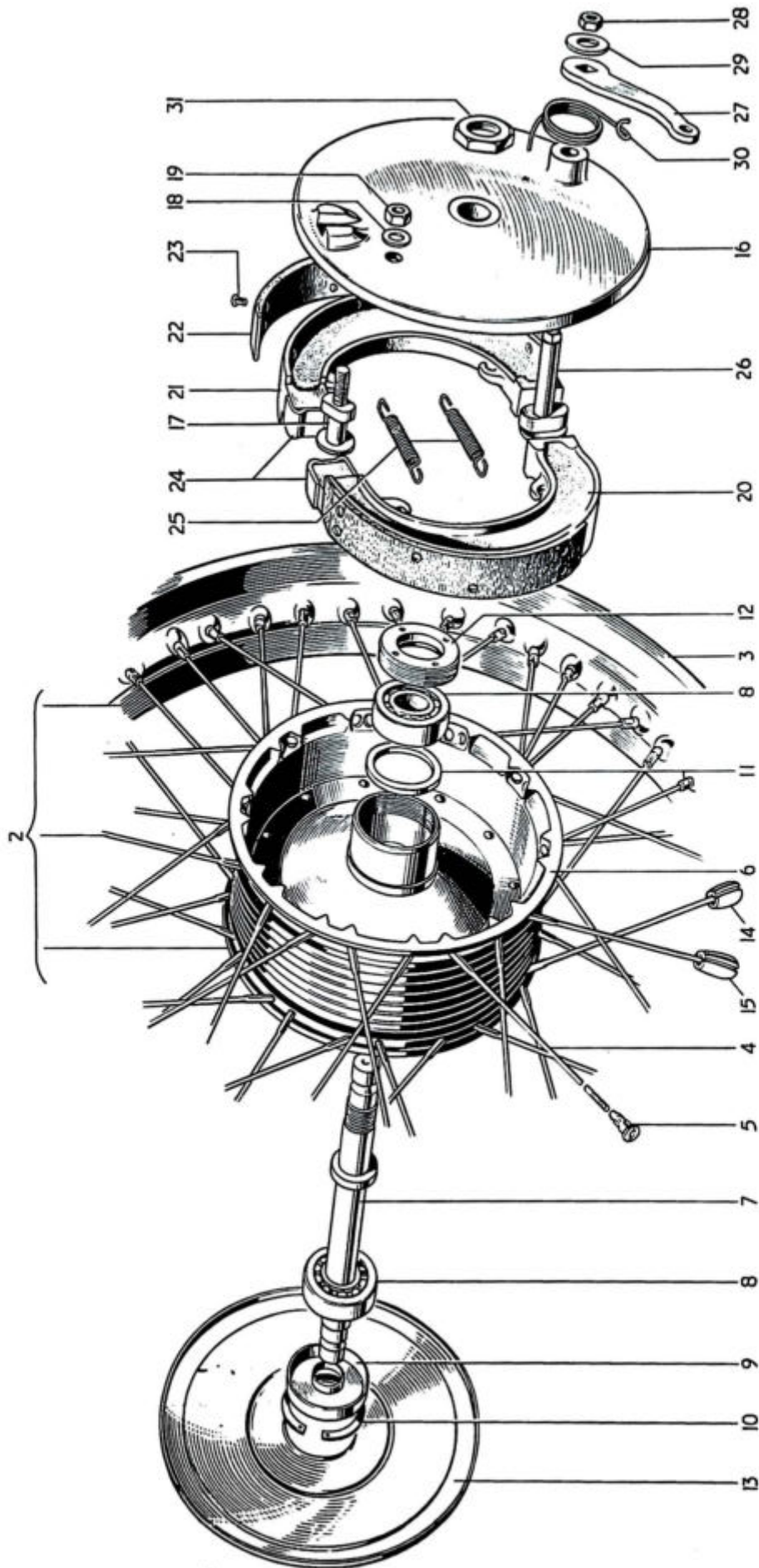

Fig. 17. FRONT WHEEL

Ref No.	Part No.	DESCRIPTION	QUANTITY			
			3TA	5TA	T100A	T100SS
FRONT WHEEL						
1	W1311	FRONT WHEEL COMPLETE	1	1	1	-
1	W1333	FRONT WHEEL COMPLETE	-	-	-	1
2	W1273	RIM, SPOKES AND HUB ASSEMBLY	1	1	1	-
2	W1229	RIM, SPOKES AND HUB ASSEMBLY	-	-	-	1
3	W1274	Front wheel rim WM2-17	1	1	1	-
3	W1230	Front wheel rim WM2-19	-	-	-	1
4	W1275	Spoke (8/10G x 5 $\frac{1}{8}$ in. straight) c/w nipple ...	40	40	40	-
4	W1236	Spoke (8/10G x 6 in. straight) c/w nipple ...	-	-	-	40
5	S79-2	Spoke nipple	40	40	40	40
6	W1231	Hub and brake drum	1	1	1	1
7	W1239	Wheel spindle	1	1	1	1
8	W653	Bearing	2	2	2	2
9	W1237	Dust cover	1	1	1	1
10	T280	Circlip	1	1	1	1
11	W1238	Backing ring	1	1	1	1
12	W582	Retaining ring	1	1	1	1
13	W1334	Cover plate	1	1	1	1
14	W1197	Balance weight $\frac{1}{2}$ oz.		as required		
15	W1198	Balance weight 1 oz.		as required		
16	W1301	Brake anchor plate	1	1	1	1
17	W1302	Fulcrum pin	1	1	1	1
18	S25-2	Plain washer	1	1	1	1
19	S1-52	Nut	1	1	1	1
20	W1406	LEADING BRAKE SHOE C/W LINING	1	1	1	1
21	W1407	TRAILING BRAKE SHOE C/W LINING	1	1	1	1
22	NW243	Brake lining	2	2	2	2
23	W129	Brass rivet	16	16	16	16
24	W1415	Thrust pad	2	2	2	2
25	W135	Shoe return spring	2	2	2	2
26	W1243	Brake cam	1	1	1	1
27	W1298X	Brake cam lever	1	1	1	1
28	S1-52	Nut	1	1	1	1
29	S25-6	Plain washer	1	1	1	1
30	W592	Lever return spring	1	1	1	1
31	W1246	Anchor plate nut	1	1	1	1

Ref. No.	Part No.	DESCRIPTION	3TA	5TA	T100A	T100SS
REAR WHEEL						
1	W1433	REAR WHEEL COMPLETE	1	1	1	-
1	W1417	REAR WHEEL COMPLETE	-	-	-	1
2	W1434	RIM, SPOKES AND HUB ASSEMBLY	1	1	1	-
2	W1416	RIM, SPOKES AND HUB ASSEMBLY	-	-	-	1
3	W1435	Rear wheel rim WM2-17	1	1	1	-
3	W1007	Rear wheel rim WM3-18	-	-	-	1
4	W1270	Spoke (8/10G x 7 $\frac{1}{8}$ in. 110°) c/w nipple	20	20	20	-
4	W1107	Spoke (8/10G x 7 $\frac{7}{8}$ in. 90°) c/w nipple	-	-	-	20
5	W1271	Spoke (8/10G x 7 $\frac{1}{8}$ in. 90°) c/w nipple	20	20	20	-
5	W1107	Spoke (8 10G x 7 $\frac{7}{8}$ in. 90°) c/w nipple	-	-	-	20
6	S79-2	Spoke nipple	40	40	40	40
7	W1266	Hub	1	1	1	1
8	W1276	Sprocket and brake drum 43T	1	1	1	1
9	W62	Sprocket to hub bolt ($\frac{1}{8}$ in. U.H.)	8	8	8	8
10	S1-51	Nut	8	8	8	8
11	W63	Locking plate	8	8	8	8
12	W1281	Wheel spindle	1	1	1	1
13	W1022	Backing ring	1	1	1	1
14	W653	Bearing	1	1	1	1
15	W1021	RETAINING RING	1	1	1	1
16	W1079	Locking screw ($\frac{7}{8}$ in. U.H.)	1	1	1	1
17	W1278	Distance tube	1	1	1	1
18	W1024	Distance piece	1	1	1	1
19	W1112	Brake anchor plate	1	1	1	1
20	W1282	Nut	1	1	1	1
21	W1406	LEADING BRAKE SHOE C/W LINING	1	1	1	1
22	W1407	TRAILING BRAKE SHOE C/W LINING	1	1	1	1
23	NW243	Brake lining	2	2	2	2
24	W129	Brass rivet	16	16	16	16
25	W1415	Thrust pad	2	2	2	2
26	W135	Shoe return spring	2	2	2	2
27	W1083	Brake cam	1	1	1	1
28	W1316	Brake cam lever	1	1	1	1
29	S1-52	Nut	1	1	1	1
30	W1090	Lever return spring	1	1	1	1
31	W1277	Speedometer adaptor	1	1	1	1
32	DSS7	Bolt ($\frac{7}{8}$ in. U.H.)	3	3	3	3
33	E1612	Serrated washer	3	3	3	3
34	W1279	Distance piece	1	1	1	1
35	D373	Speedometer gearbox	1	1	1	1
36	W1280	Plain washer	1	1	1	1
37	F1747	Nut	1	1	1	1
38	W1134	Chain adjuster	2	2	2	2
39	W1015	Adjuster end plate	2	2	2	2
40	W1058	Self-locking nut	2	2	2	2
41	F1747	Spindle nut	2	2	2	2
42	WM3	Tyre security bolt	-	-	-	1

QUICKLY DETACHABLE REAR WHEEL

						3TA	5TA	T100A	T100SS
1	W1436	Q.D. REAR WHEEL COMPLETE	1	1	1	-
1	W1429	Q.D. REAR WHEEL COMPLETE	-	-	-	1
2	W1437	RIM, SPOKES AND HUB ASSEMBLY	1	1	1	-
2	W1427	RIM, SPOKES AND HUB ASSEMBLY	1	-	-	1
3	W1435	Rear wheel rim WM2-17	1	1	1	-
3	W1007	Rear wheel rim WM3-18	-	-	-	1
4	W1271	Spoke (8/10G x 7 $\frac{1}{8}$ in. 90°) c/w nipple	20	20	20	-
4	W1107	Spoke (8/10G x 7 $\frac{1}{16}$ in. 90°) c/w nipple	-	-	-	20
5	W1377	Spoke (8/10G x 7 $\frac{1}{8}$ in. 90°) c/w nipple	20	20	20	-
5	W1108	Spoke (8/10G x 7 $\frac{1}{8}$ in. 90°) c/w nipple	-	-	-	20
6	S79-2	Spoke nipple	40	40	40	40
7	W1388	Hub	1	1	1	1
8	W1033	Backing ring	2	2	2	2
9	W1034	Taper roller bearing complete	2	2	2	2
10	W1035	Dust cap	1	1	1	1
11	W1390	Bearing sleeve	1	1	1	1
12	W1391	Distance piece	2	2	2	2
13	F1747	Nut	1	1	1	1
14	D373	Speedometer gearbox	1	1	1	1
15	W1280	Plain washer	1	1	1	1
16	E398	Nut	1	1	1	1
17	W1091	Rubber sealing ring	1	1	1	1
18	W1376	Sprocket and brake drum 43T	1	1	1	1
19	W1143	Grease retainer	1	1	1	1
20	W1041	Bearing	1	1	1	1
21	W1042	Felt washer	1	1	1	1
22	W1043	Bearing and felt retainer	1	1	1	1
23	W1044	Circlip	1	1	1	1
24	W1393	Bearing sleeve	1	1	1	1
25	W1395	Brake anchor plate	1	1	1	1
26	W1406	LEADING BRAKE SHOE C/W LINING	1	1	1	1
27	W1407	TRAILING BRAKE SHOE C/W LINING	1	1	1	1
28	NW243	Brake lining	2	2	2	2
29	W129	Brass rivet	16	16	16	16
30	W1415	Thrust pad	2	2	2	2
31	W135	Shoe return spring	2	2	2	2
32	W1083	Brake cam	1	1	1	1
33	W1316	Brake cam lever	1	1	1	1
34	S1-52	Nut	1	1	1	1
35	W1090	Lever return spring	1	1	1	1
36	W1052	Nut	1	1	1	1
37	W1392	Inner distance piece	1	1	1	1
38	W1170	Outer distance piece	1	1	1	1
39	W1055	Spindle	1	1	1	1
40	W1135	Chain adjuster	2	2	2	2
41	W1015	Adjuster end plate	2	2	2	2
42	W1058	Self-locking nut	2	2	2	2
43	WM3	Tyre security bolt	-	-	-	1

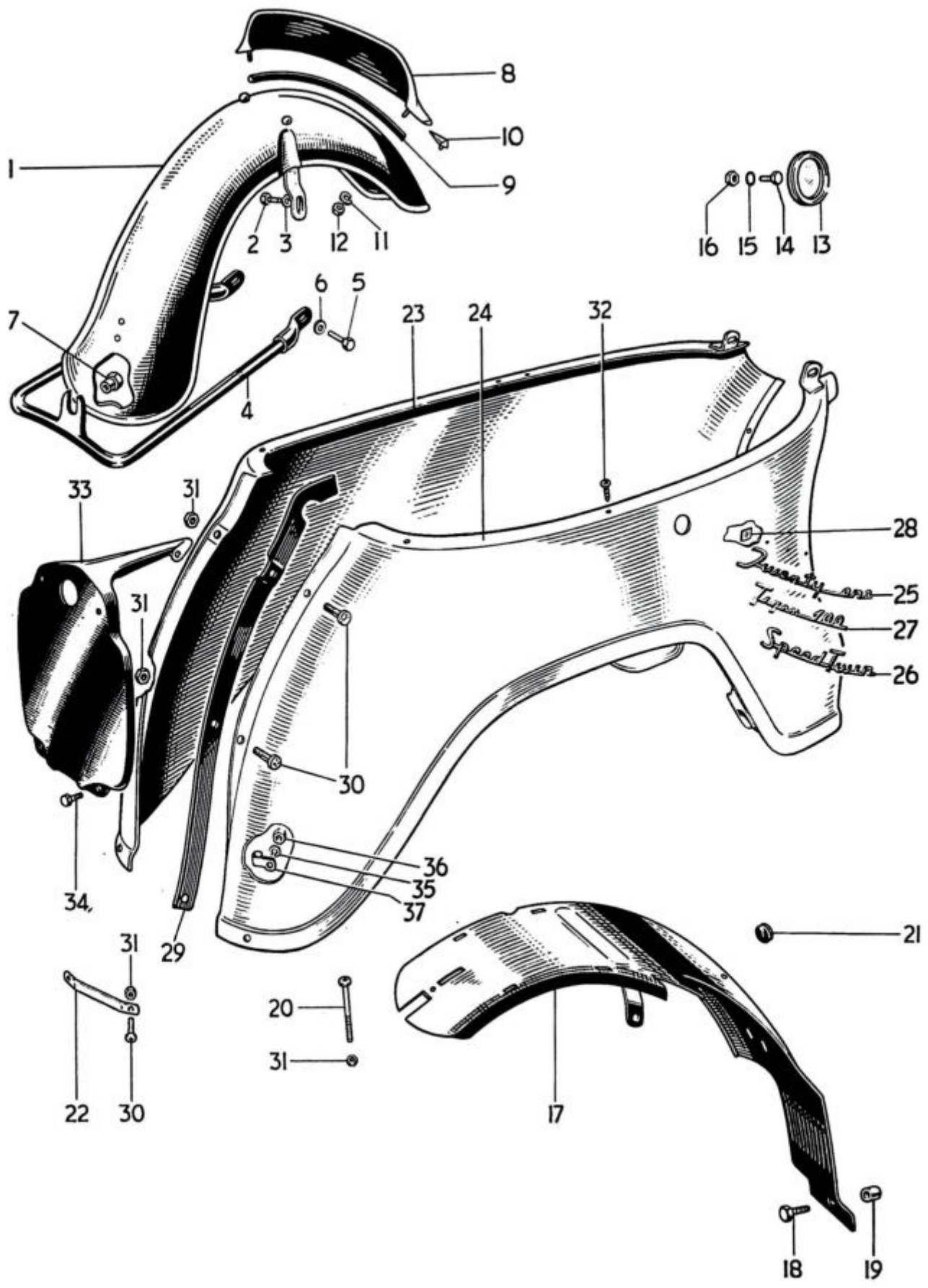

Fig. 20. MUDGUARDS AND REAR PANELS.

MUDGUARDS AND REAR PANELS

										3TA	5TA	T100A
1	H1097	Front mudguard	1	1	1
2	F929	Bolt ($\frac{1}{2}$ in. U.H.)	2	2	2
3	F4299	Plain washer	2	2	2
4	H1100	Bottom stay	1	1	1
5	W62	Bolt ($\frac{1}{4}$ in. U.H.)	2	2	2
6	S25-2	Plain washer	2	2	2
7	NS362	Spigot nut	1	1	1
8	F2698	Number plate	1	1	1
9	H251	Beading	1	1	1
10	F4332	Packing piece	1	1	1
11	S26-2	Spring washer	2	2	2
12	F879	Nut	2	2	2
13	D261	Licence holder	1	1	1
14	DS57	Bolt	1	1	1
15	E1612	Serrated washer	1	1	1
16	F879	Nut	1	1	1
17	F4297	Rear mudguard	1	1	1
18	F1369	Bolt ($\frac{5}{8}$ in. U.H.)	1	1	1
19	H1015	Distance piece	1	1	1
20	F4716	Screw ($1\frac{1}{8}$ in. U.H.)	1	1	1
21	F3327	Blind grommet	1	1	1
22	F4897	Backing strip	1	1	1
23	F4768	Left panel	1	1	1
24	F4769	Right panel	1	1	1
25	F4312	Motif "Twentyone"	2	-	-
26	F4523	Motif "Speed Twin"	-	2	-
27	F4524	Motif "Tiger 100"	-	-	2
28	F4317	Spire nut	6	6	6
29	F4249	Joint beading	2	2	2
30	F4715	Screw ($\frac{1}{2}$ in. U.H.)	6	6	6
31	F4717	Nut	7	7	7
32	F4483	Self-tapping screw	4	4	4
33	F4686	Number plate	1	1	1
34	F1369	Bolt ($\frac{5}{8}$ in. U.H.)	2	2	2
35	S26-2	Spring washer	2	2	2
36	F879	Nut	2	2	2
37	F3098	Vent pipe clip	1	1	1

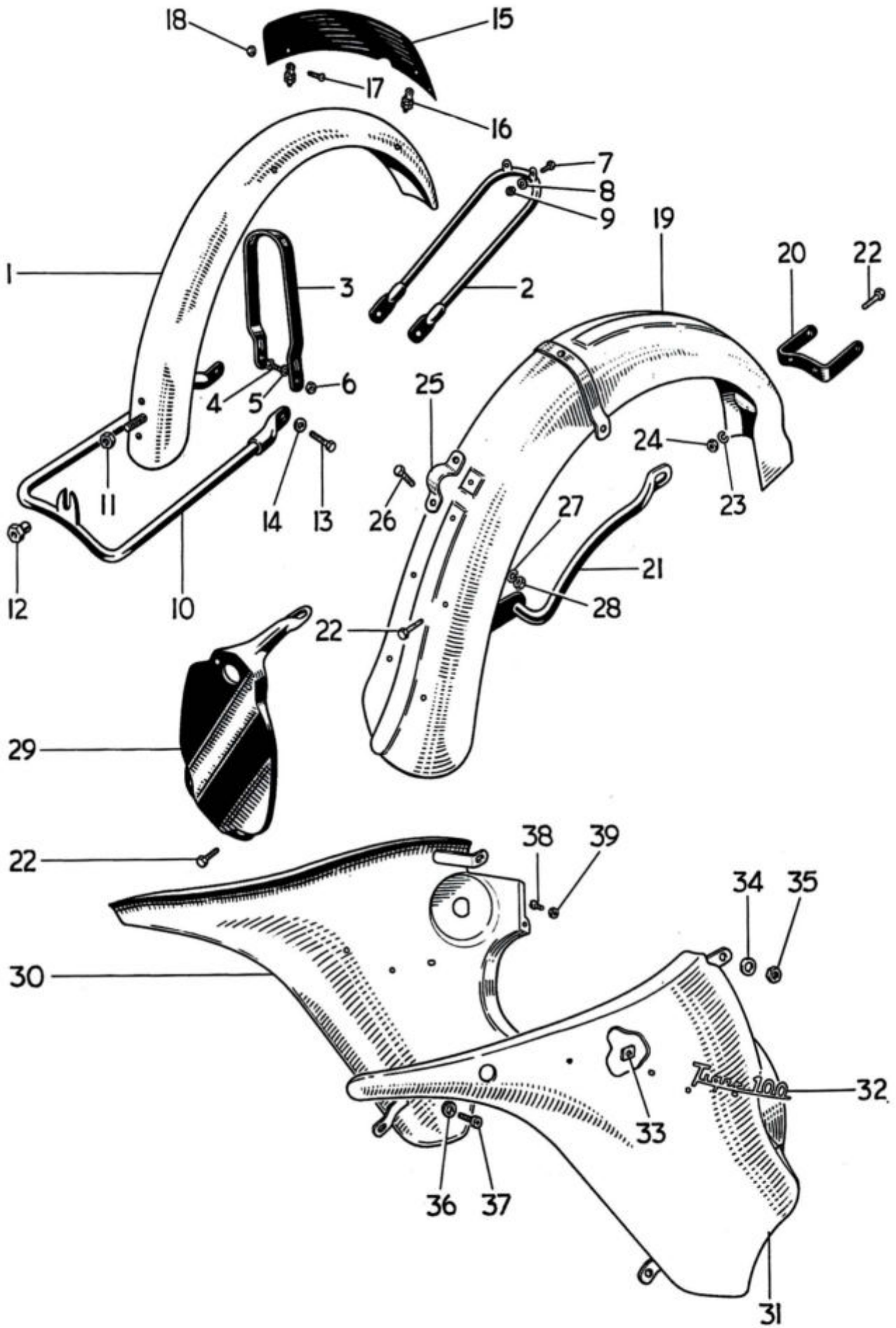

Fig. 21. MUDGUARDS AND REAR PANELS T100SS

MUDGUARDS AND REAR PANELS- T100SS

												T100SS	
1	H.1294	Mudguard blade	1
2	H.1271	Front stay	1
3	H.1295	Mudguard bridge	1
4	H.590	Bolt ($\frac{7}{8}$ in. U.H.)	4
5	F.4299	Plain washer	2
6	T.224	Nut	2
7	DS.57	Bolt ($\frac{7}{8}$ in. U.H.)	4
8	S25-1	Plain washer	4
9	F.879	Nut	4
10	H.412	Bottom stay	1
11	S1-51	Nut	1
12	NS.362	Spigot nut	1
13	H.414	Bolt ($\frac{39}{64}$ in. U.H.)	2
14	S25-71	Plain washer	2
15	F.2996	Number plate	1
16	H.741	Clip assembly	2
17	H.687	Screw ($\frac{3}{8}$ in. U.H.)	2
18	H.745	Nut	2
19	F.4858	Rear mudguard	1
20	F.4861	Bracket	1
21	F.4856	Lifting handle	1
22	DS.57	Bolt	6
23	S26-2	Spring washer	6
24	F.879	Nut	6
25	F.4690	Clip	1
26	F.929	Bolt ($\frac{1}{2}$ in. U.H.)	2
27	S26-3	Spring washer	2
28	S1-51	Nut	2
29	F.3363	Number plate	1
30	F.5094	Left panel	1
31	F.5096	Right panel	1
32	F.4524	Motif "Tiger 100"	2
33	F.4317	Spire nut	6
34	S25-2	Plain washer	2
35	S1-52	Nut	2
36	F.4512	Rubber washer	2
37	F.4483	Self tapping screw	2
38	F.4715	Screw ($\frac{1}{2}$ in. U.H.)	2
39	F.4717	Nut	2

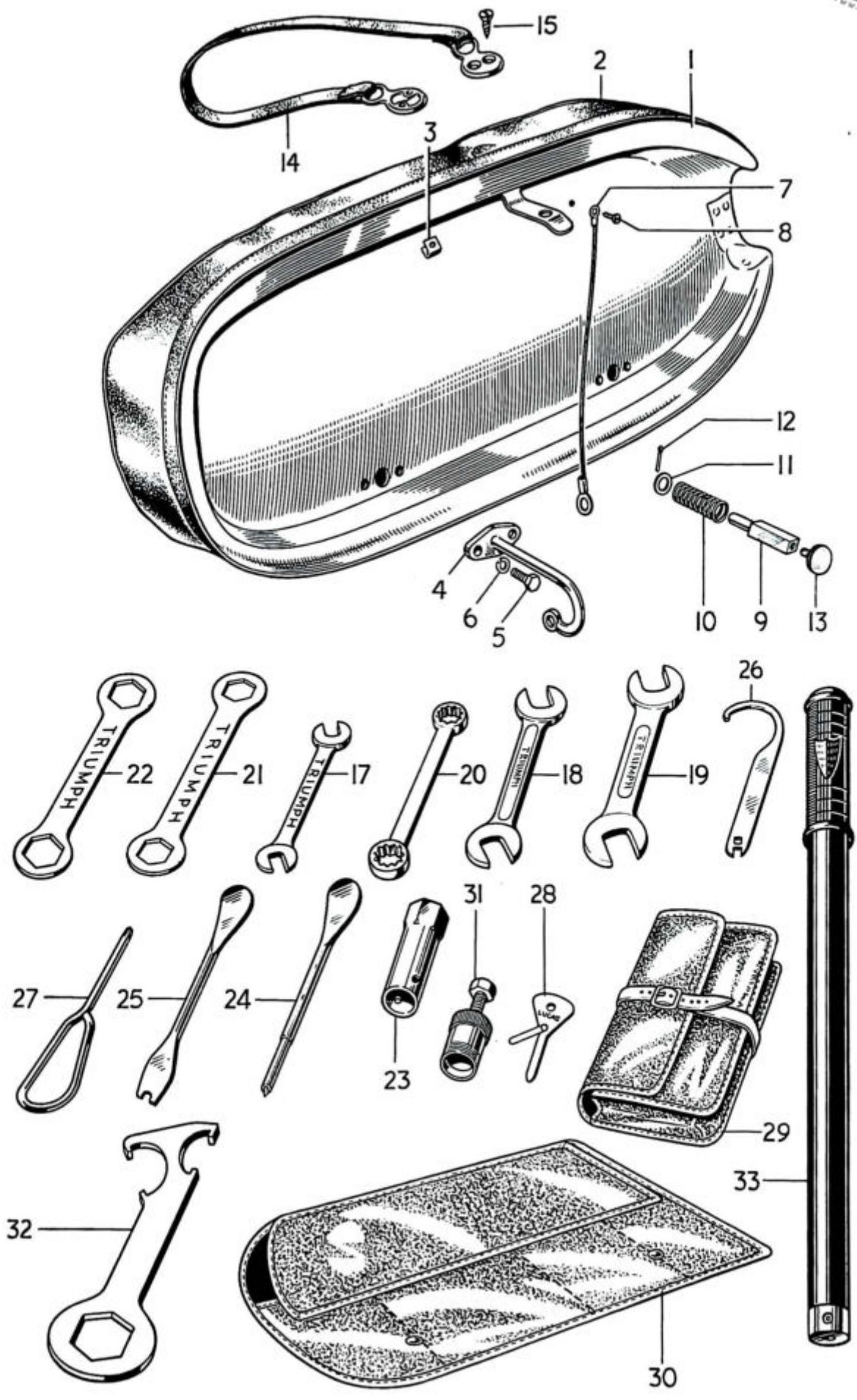

Fig. 22. TWINSEAT AND TOOLKIT.

Ref. No.	Part No.	DESCRIPTION	3TA	5TA	T100A	T100SS
TWINSEAT AND TOOLKIT						
1	F4239	TWINSEAT	1	1	1	1
2	F4244	Twinseat cover c/w clips	1	1	1	1
3	F4475	Clip		as required		
4	F4222	Hinge	2	2	2	2
5	DS57	Bolt ($\frac{7}{8}$ in. U.H.)	4	4	4	4
6	S26-2	Spring washer	4	4	4	4
7	D374	Check wire	1	1	1	1
8	F4483	Self-tapping screw	1	1	1	1
9	F4226	Seat catch plunger	1	1	1	1
10	F4228	Spring	1	1	1	1
11	E1719A	Plain washer	1	1	1	1
12	$\frac{3}{8}$ in. x $\frac{1}{2}$ in.	Split pin	1	1	1	1
13	F4227	Knob	1	1	1	1
14	F4361	Safety strap	A	A	A	A
15	F4365	Self-tapping screw	4	4	4	4
16	D446	TOOL KIT	-	-	-	1
17	D360	Open spanner, $\frac{1}{8}$ in. x $\frac{3}{32}$ in. whit.	1	1	1	1
18	NA55	Open spanner, $\frac{1}{4}$ in. x $\frac{7}{8}$ in. whit.	1	1	1	1
19	DA16	Open spanner, $\frac{3}{8}$ in. x $\frac{7}{8}$ in. whit.	1	1	1	1
20	D370	Ring spanner, $\frac{7}{8}$ in. x $\frac{1}{4}$ in. whit.	1	1	1	1
21	PA57	Ring spanner, $\frac{1}{2}$ in. x $\frac{1}{8}$ in. whit.	1	1	1	1
22	D311	Ring spanner, $\frac{3}{8}$ in. x $\frac{1}{16}$ in. whit.	1	1	1	1
23	D87	Box spanner, spark plug	1	1	1	1
24	D363	Tyre lever and tommy bar	1	1	1	1
25	D364	Tyre lever and clutch key	1	1	1	1
26	D362	"C" spanner and tappet key	1	1	1	1
27	D336	Phillips No. 3 screwdriver	1	1	1	1
28	400935	Ignition screwdriver and feeler gauge	1	1	1	1
29	WA58	Tool roll	-	-	-	1
30	F5084	Tool bag	1	1	1	-
31	DA50/1	Clutch extractor	A	A	A	A
32	D220	Fork spanner	A	A	A	A
33	D296	Tyre inflator	1	1	1	1

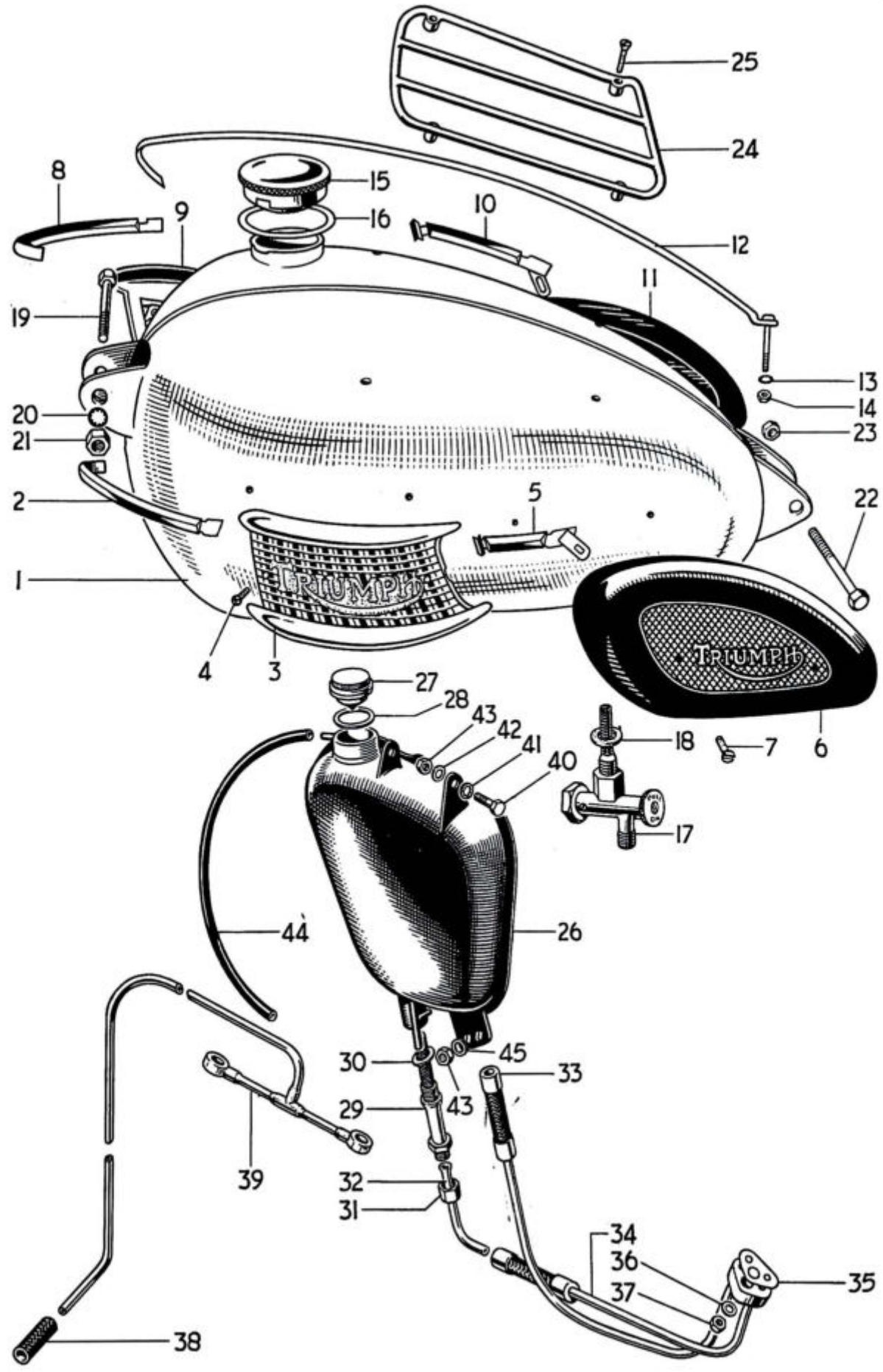

Fig 23. PETROL AND OIL TANKS.

PETROL AND OIL TANKS

									3TA	5TA	T100A	T100SS
1	F4232	Petrol Tank	1	1	1	1
2	F4235	Styling strip (Left front)	A	A	1	1
3	F4127	Styling unit (Left)	1	1	1	1
4	F4129	Styling unit screw (0.435 in. U.H.)	4	4	4	4
5	F4323	Styling strip (Left rear)	A	A	1	1
6	F2551	Knee grip (Left)	1	1	1	1
7	F1953	Knee grip screw ($\frac{5}{8}$ in. U.H.)	4	4	4	4
8	F4237	Styling strip (Right front)	A	A	1	1
9	F4128	Styling unit (Right)	1	1	1	1
10	F4324	Styling strip (Right rear)	A	A	1	1
11	F2552	Knee grip (Right)	1	1	1	1
12	F4398	Centre styling strip	1	1	1	1
13	F4019	Serrated washer	1	1	1	1
14	H919	Nut	1	1	1	1
15	F3220	FILLER CAP	1	1	1	1
16	F4048	Joint washer	1	1	1	1
17	F1717	Petrol tap	1	1	1	1
18	F1511	Fibre washer	1	1	1	1
19	F4382	Bolt ($3\frac{1}{2}$ in. U.H.)	1	1	1	1
20	E2288	Serrated washer	2	2	2	2
21	PO172A	Nut	1	1	1	1
22	E327	Bolt ($3\frac{3}{8}$ in. U.H.)	1	1	1	1
23	W76	Nut	1	1	1	1
24	F3917	Parcel grid	1	1	1	1
25	F2936	Parcel grid screw	4	4	4	4
26	F4476	Oil tank	1	1	1	-
27	F4477	FILLER CAP	1	1	1	-
28	F4478	Joint washer	1	1	1	-
29	F4533	Oil tank filter	1	1	1	-
30	F1713	Fibre washer	1	1	1	-
31	F3182	Union nut	1	1	1	-
32	E4113	Upper feed pipe	1	1	1	-
33	MF119/20	Rubber connector	2	2	2	-
34	E4083	Oil pipes and junction block	1	1	1	-
35	E3763	Joint washer	1	1	1	-
36	S25-3	Plain washer	1	1	1	-
37	E1310	Nut	1	1	1	-
38	E3383	Rubber connector	1	1	1	-
39	E3805	Rocker oil feed pipe	1	1	1	-
40	F1213	Bolt ($\frac{1}{2}$ in. U.H.)	2	2	2	-
41	E2287	Serrated washer	1	1	1	-
42	GS203	Plain washer	2	2	2	-
43	W1058	Nut	3	3	3	-
44	T1579	Vent pipe	1	1	1	-
45	F4299	Plain washer	1	1	1	-

For T100SS oil tank see Page 62.

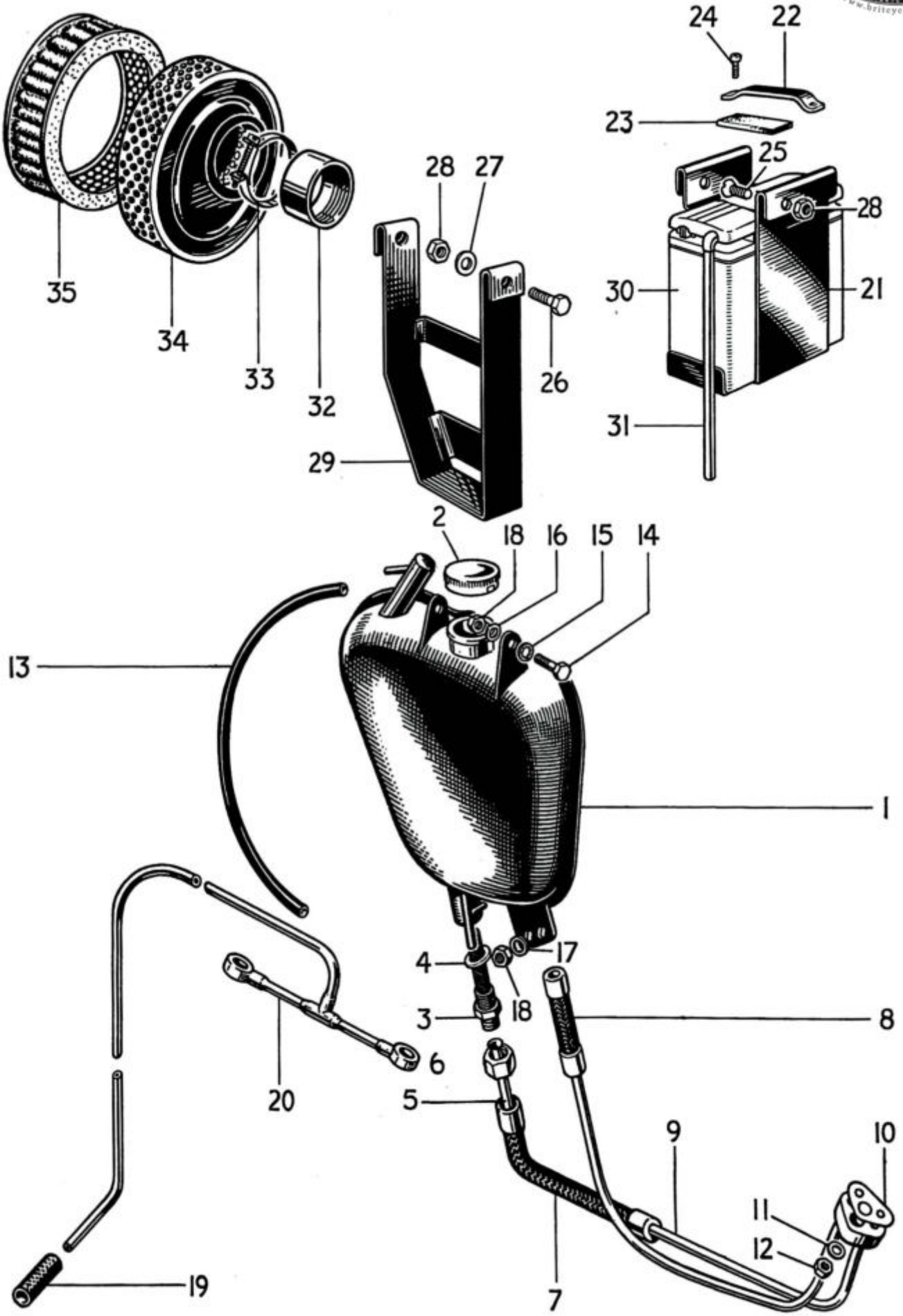

Fig. 24. T100SS OIL TANK, BATTERY CARRIER AND TOOL CARRIER

Ref. No.	Part No.	DESCRIPTION	QUANTITY
T100SS OIL TANK, BATTERY CARRIER AND TOOL CARRIER			T100SS
1	F4851	Oil tank	1
2	F3216	Filler cap	1
3	F3179	Oil tank filter	1
4	F1713	Fibre washer	1
5	F3655	Upper feed pipe	1
6	F3182	Union nut	1
7	E3353	Rubber feed pipe	1
8	MF119/20	Rubber return pipe	1
9	E4083	Oil pipe and junction block	1
10	E3763	Joint washer	1
11	S25-3	Plain washer	1
12	E1310	Nut	1
13	T1579	Vent pipe	1
14	F1213	Bolt ($\frac{1}{8}$ in. U.H.)	2
15	E2287	Serrated washer	1
16	GS203	Plain washer	2
17	F4249	Plain washer	1
18	W1058	Nut	3
19	E3383	Rubber connector	1
20	E3805	Rocker oil feed pipe	1
21	F5147	Battery carrier	1
22	F4661	Top strap	1
23	F4662	Packing rubber	1
24	E3200	Screw ($\frac{1}{8}$ in. U.H.)	1
25	E3728	Screw ($\frac{1}{16}$ in. U.H.)	1
26	D257	Bolt ($\frac{1}{8}$ in. U.H.)	2
27	S25-1	Plain washer	3
28	F879	Nut	3
29	F4875	Tool carrier	1
30	MLZ9E	Battery c/w lid	1
31	F4816	Plastic vent pipe	1
32	F4812	Adaptor	1
33	F3859	Clip	1
34	F4806	AIR FILTER	1
35	F4811	Filter element	1

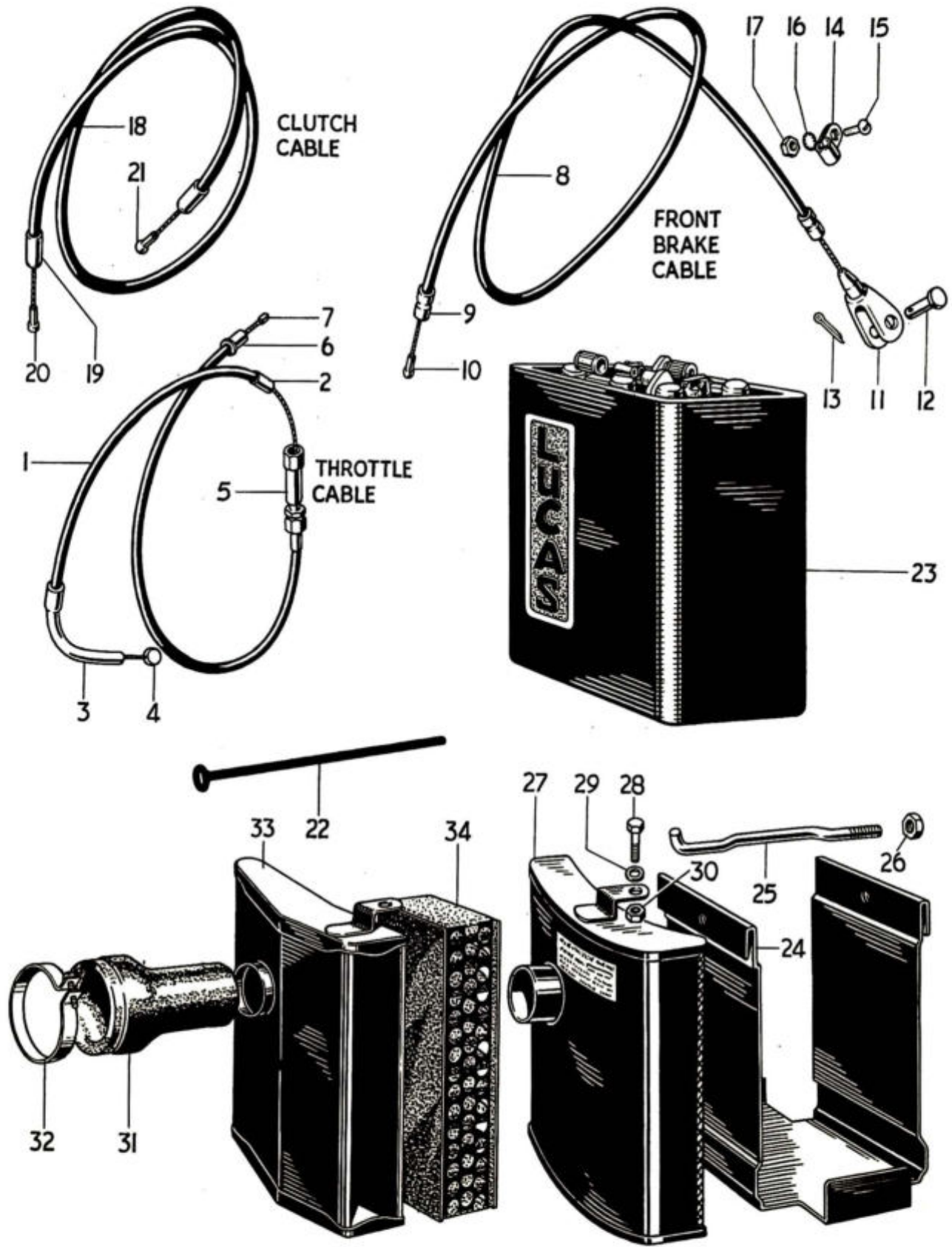

Fig. 25. CONTROL CABLES, BATTERY CARRIER AND AIR FILTER.

Ref. No. Part No.

DESCRIPTION

CONTROL CABLES

									3TA	5TA	T100A	T100SS
1	D383	THROTTLE CABLE	1	1	1	-
1	D442	THROTTLE CABLE	-	-	-	1
1	D410	AMERICAN THROTTLE CABLE	A	A	A	-
2	D101	Ferrule	3	3	3	3
3	H670	Guide tube	1	1	1	-
4	D83	Nipple	1	1	1	-
4	D443	Nipple	-	-	-	1
5	D104	Adjuster	1	1	1	1
6	6/132A	Ferrule	1	1	1	1
7	NS191	Nipple	1	1	1	1
8	D418	FRONT BRAKE CABLE	1	1	1	-
8	D419	AMERICAN FRONT BRAKE CABLE	A	A	A	1
9	D103	Ferrule	2	2	2	2
10	D368	Nipple	1	1	1	1
11	W593	Fork end	1	1	1	1
12	WF32	Pivot pin	1	1	1	1
13	$\frac{1}{8}$ in. x $\frac{3}{8}$ in.	Split pin	1	1	1	1
14	H1171	Clip	1	1	1	1
15	H916	Screw ($\frac{9}{32}$ in. U.H.)	1	1	1	1
16	GS299	Serrated washer	1	1	1	1
17	H745	Nut	1	1	1	1
18	*D366	CLUTCH CABLE	1	1	1	-
18	*D408	AMERICAN CLUTCH CABLE	A	A	A	-
19	D103	Ferrule	2	2	2	2
20	D368	Nipple	1	1	1	1
21	DS73	Nipple	1	1	1	1
22	XA69	Cable clip		as required		
*After engine No. H25252 use:												
18	D452	CLUTCH CABLE	1	1	-	1
18	D466	AMERICAN CLUTCH CABLE	1	1	-	-

BATTERY CARRIER AND AIR FILTER

23	PUZ7E-11	Battery	1	1	1	-
24	F4219	Battery Carrier	1	1	1	-
25	F4485	Clamp rod	1	1	1	-
26	F879	Nut	1	1	1	-
27	*F4218	Air filter	1	1	1	-
28	DS57	Bolt ($\frac{7}{8}$ in. U.H.)	1	1	1	-
29	S25-43	Plain washer	1	1	1	-
30	F879	Nut	1	1	1	-
31	E3985	Rubber connector	1	1	-	-
31	E4216	Rubber connector	-	-	1	-
32	F3859	Clip	1	1	1	-
*For later Models use:												
33	F5129	AIR FILTER	1	1	-	-
34	F5137	Element	1	1	-	-

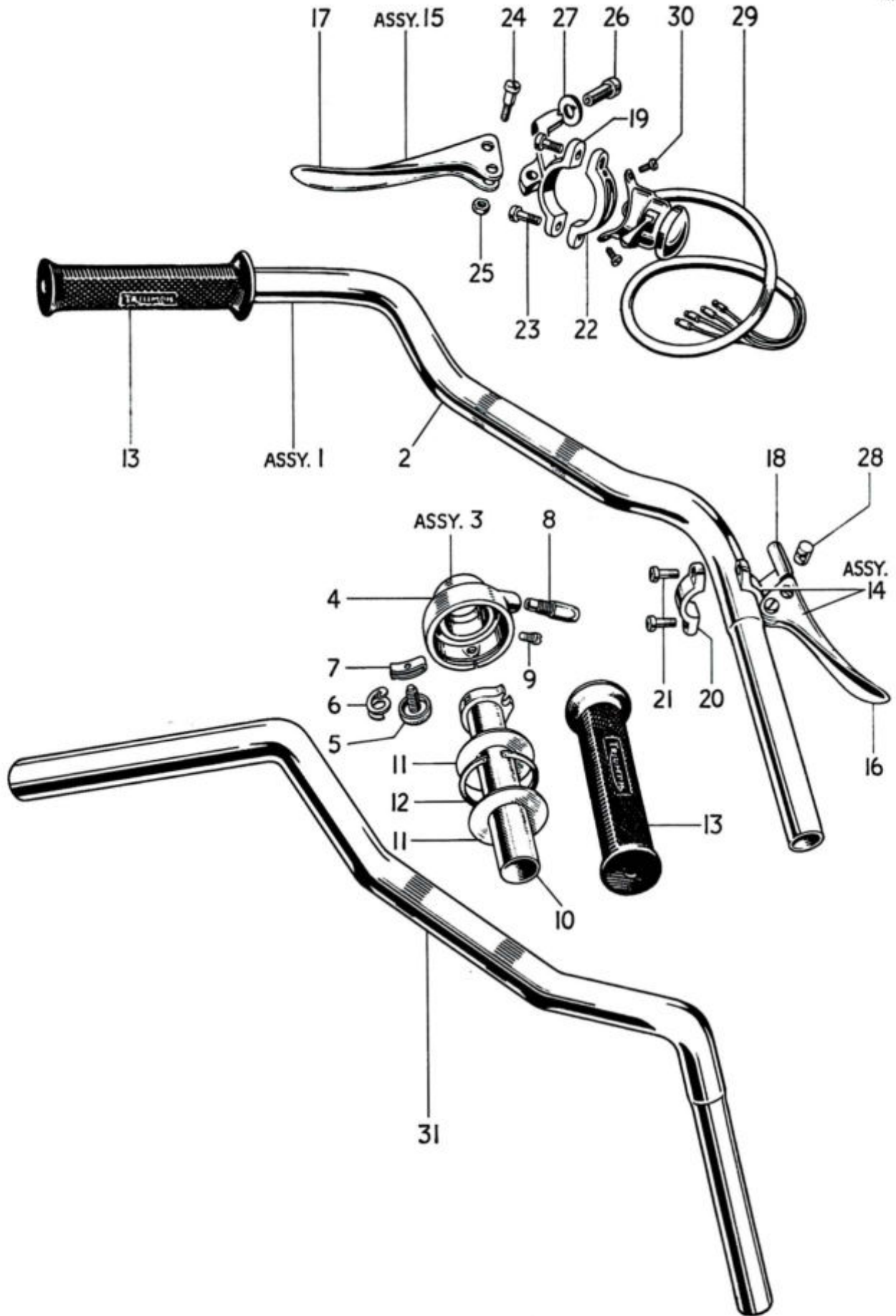

Fig. 26. HANDLEBAR AND CONTROL LEVERS.

Ref. No.	Part No.	DESCRIPTION	3TA	5TA	T100A
HANDLEBAR AND CONTROL LEVERS					
1	H1176	HANDLEBAR c/w CONTROLS	1	1	1
2	H1131	Handlebar	1	1	1
3	H697	TWISTGRIP ASSEMBLY	1	1	1
4	H698	Twistgrip head assembly (Nos. 5-9)	1	1	1
5	H665	Friction screw	1	1	1
6	H685	Spring	1	1	1
7	H686	Friction spring	1	1	1
8	H234	Cable thimble	1	1	1
9	H237	Grub screw	1	1	1
10	H700	Sleeve	1	1	1
11	H233	Retaining plate	2	2	2
12	H232	Circlip	1	1	1
13	H230	Rubber grip (and at left handlebar)	2	2	2
14	18/886	FRONT BRAKE LEVER	1	1	1
15	18/894	CLUTCH LEVER	1	1	1
16	18/535	Brake lever	1	1	1
17	18/528	Clutch lever	1	1	1
18	18/890	Brake lever bracket	1	1	1
19	18/892	Clutch lever bracket	1	1	1
20	12/044	Clamp	1	1	1
21	11/014	Screw	2	2	2
22	H668	Clamp	1	1	1
23	61/004	Screw	2	2	2
24	18/087	Fulcrum screw	2	2	2
25	18/053	Self-locking nut	2	2	2
26	18/838	Cable adjuster	2	2	2
27	18/839	Thumb nut	2	2	2
28	18/880	Barrel nipple	2	2	2
29	31563	Horn push and dip switch	1	1	1
30	H689	Screw (½ in. U.H.)	2	2	2
31	H1247	American Handlebar	A	A	A

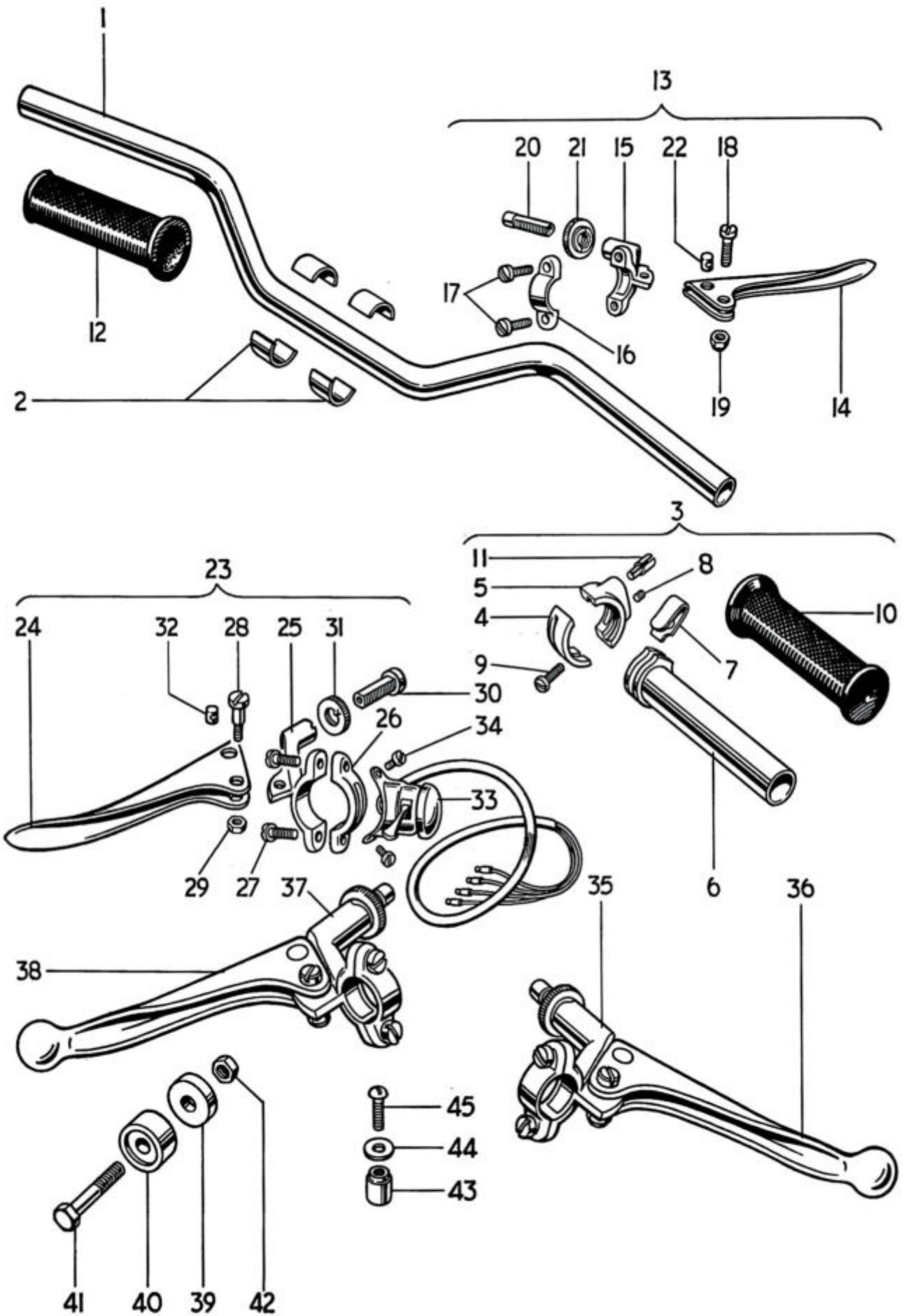

Fig. 27. T100SS HANDLEBAR AND CONTROL LEVERS

Ref. No. Part No. DESCRIPTION QUANTITY

T100SS HANDLEBAR AND CONTROL LEVERS

													T100SS
1	H527	Handlebar	1
2	H1425	Packing piece	4
3	366/2	TWISTGRIP	1
4	366/001	Body top half	1
5	366/002	Body bottom half	1
6	366/004	Rotor	1
7	366/007	Friction spring	1
8	366/008	Friction spring screw	1
9	376/079	Screw	2
10	16/070	Handlebar grip	1
11	366/006	Cable stop	1
12	16/069	Handlebar grip	1
13	18/995	FRONT BRAKE LEVER ASSEMBLY	1
14	18/535	Brake lever	1
15	18/912	Brake lever bracket	1
16	12/040	Clamp	1
17	11/014	Screw	2
18	18/087	Fulcrum screw	1
19	18/053	Self-locking nut	1
20	18/838	Cable adjuster	1
21	18/839	Thumb nut	1
22	18/880	Barrel nipple	1
23	18/996	CLUTCH LEVER ASSEMBLY	1
24	18/528	Clutch lever	1
25	18/913	Clutch lever bracket	1
26	18/910	Clamp (H668 A)	1
27	61/004	Screw	1
28	18/087	Fulcrum screw	1
29	18/053	Self-locking nut	1
30	18/838	Cable adjuster	1
31	18/839	Thumb nut	1
32	18/880	Barrel nipple	1
33	31563	Horn push and dip switch	1
34	H689	Screw (½ in. U.H.)	2
35	18/935	FRONT BRAKE LEVER ASSEMBLY (Ball-end)	A
36	18/754	Brake lever (Ball-end)	A
37	18/993	CLUTCH LEVER ASSEMBLY (Ball-end)	A
38	18/752	Clutch lever (Ball-end)	A

STEERING STOPS

													3TA	5TA
39	F5075	Left steering stop	1	1
40	F5076	Right steering stop	1	1
41	F2398	Bolt (1¼ in. U.H.)	1	1
42	S1-51	Nut	1	1
43	F5077	Fork steering stop	1	1
44	S25-1	Plain washer	1	1
45	F5078	Screw (¾ in. U.H.)	1	1

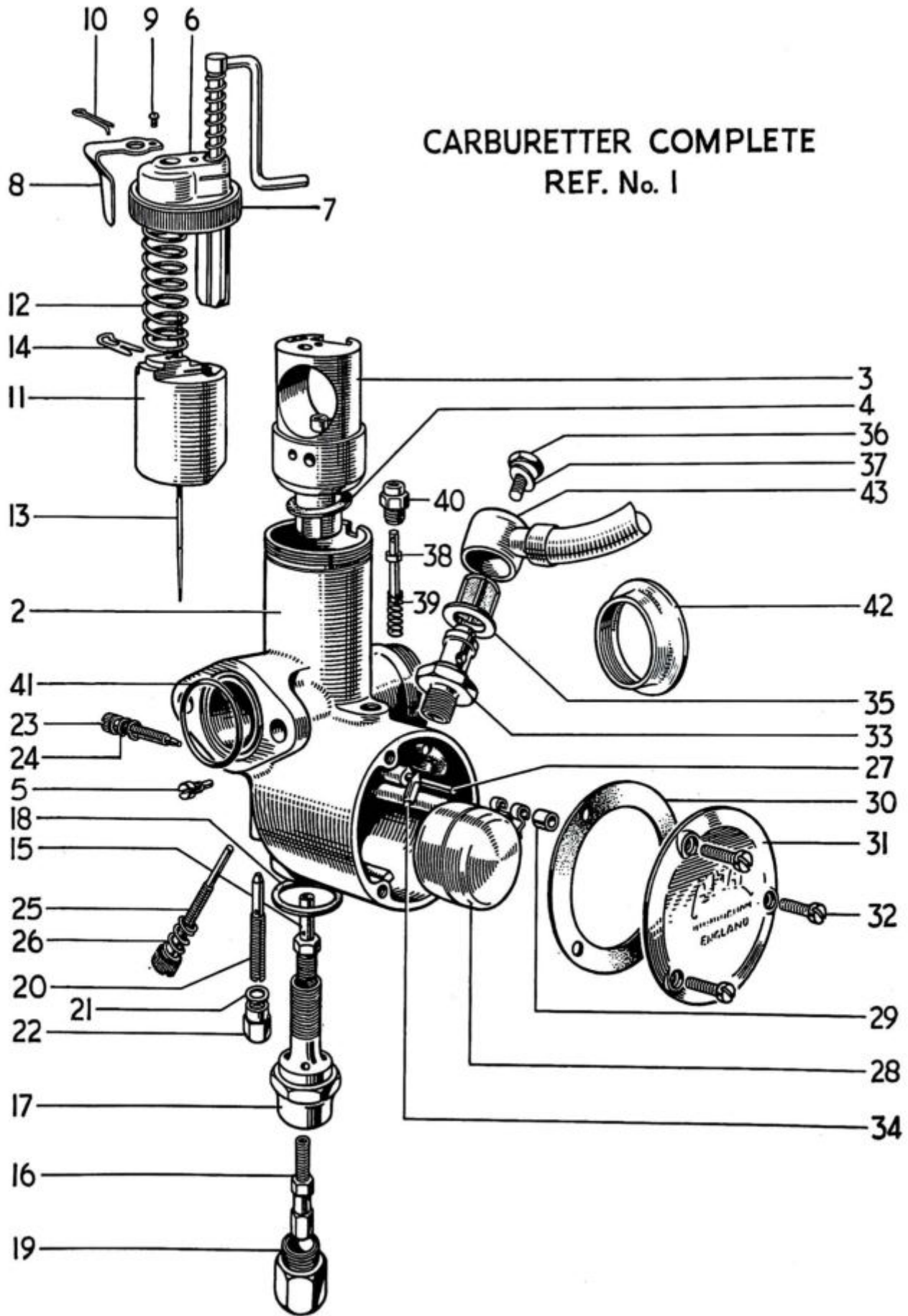

Fig. 28. CARBURETTER, 3TA and 5TA

Ref. No.	Part No.	DESCRIPTION	QUANTITY	3TA	5TA
CARBURETTER, 3TA AND 5TA					
1	375/32	CARBURETTER, $\frac{25}{32}$ in. choke	...	1	-
1	375/35	CARBURETTER, $\frac{7}{8}$ in. choke	...	-	1
2	375/003	Mixing chamber, $\frac{25}{32}$ in. choke	...	1	-
2	375/005	Mixing chamber; $\frac{7}{8}$ in. choke	...	-	1
3	375/057	Jet block, $\frac{25}{32}$ in. choke	...	1	-
3	375/059	Jet block, $\frac{7}{8}$ in. choke	...	-	1
4	375/067	Joint washer	...	1	1
5	376/070	Peg screw	...	1	1
6	375/102	AIR VALVE ASSEMBLY	...	1	1
7	375/065	Mixing chamber cap	...	1	1
8	375/071	Spring	...	1	1
9	4/241	Screw	...	1	1
10	30/064	Spring	...	1	1
11	375/060	Throttle valve ($3\frac{1}{2}$ cutaway)	...	1	-
11	375/060	Throttle valve (3 cutaway)	...	-	1
12	375/079	Throttle return spring	...	1	1
13	375/063	Needle (Type B)	...	1	1
14	4/230	Needle clip	...	1	1
15	376/072	Needle jet (.106)	...	1	-
15	376/072	Needle jet (.105)	...	-	1
16	376/100	Main jet (100)	...	1	-
16	376/100	Main jet (160)	...	-	1
17	376/073	Jet holder	...	1	1
18	376/074	Fibre washer	...	1	1
19	376/075	Cover nut	...	1	1
20	376/076	Pilot jet (25)	...	1	1
21	116/162	Fibre washer	...	1	1
22	376/095	Cover nut	...	1	1
23	332/017	Air adjusting screw	...	1	1
24	4/148	Spring	...	1	1
25	376/068	Throttle stop screw	...	1	1
26	376/069	Spring	...	1	1
27	376/085	Float spindle	...	1	1
28	376/083	Float	...	1	1
29	376/094	Bush	...	1	1
30	376/078	Joint washer	...	1	1
31	376/077	Cover	...	1	1
32	376/079	Screw	...	3	3
33	376/088	Needle seating	...	1	1
34	376/089	Needle	...	1	1
35	376/093	Filter	...	1	1
36	376/091	Bolt	...	1	1
37	376/092	Fibre washer	...	1	1
38	376/086	Tickler	...	1	1
39	376/087	Spring	...	1	1
40	343/011	Tickler body	...	1	1
41	244/765	"O" ring seal	...	1	1
42	229/048	Air intake tube	...	A	A
43	F4308	Petrol pipe	...	1	1

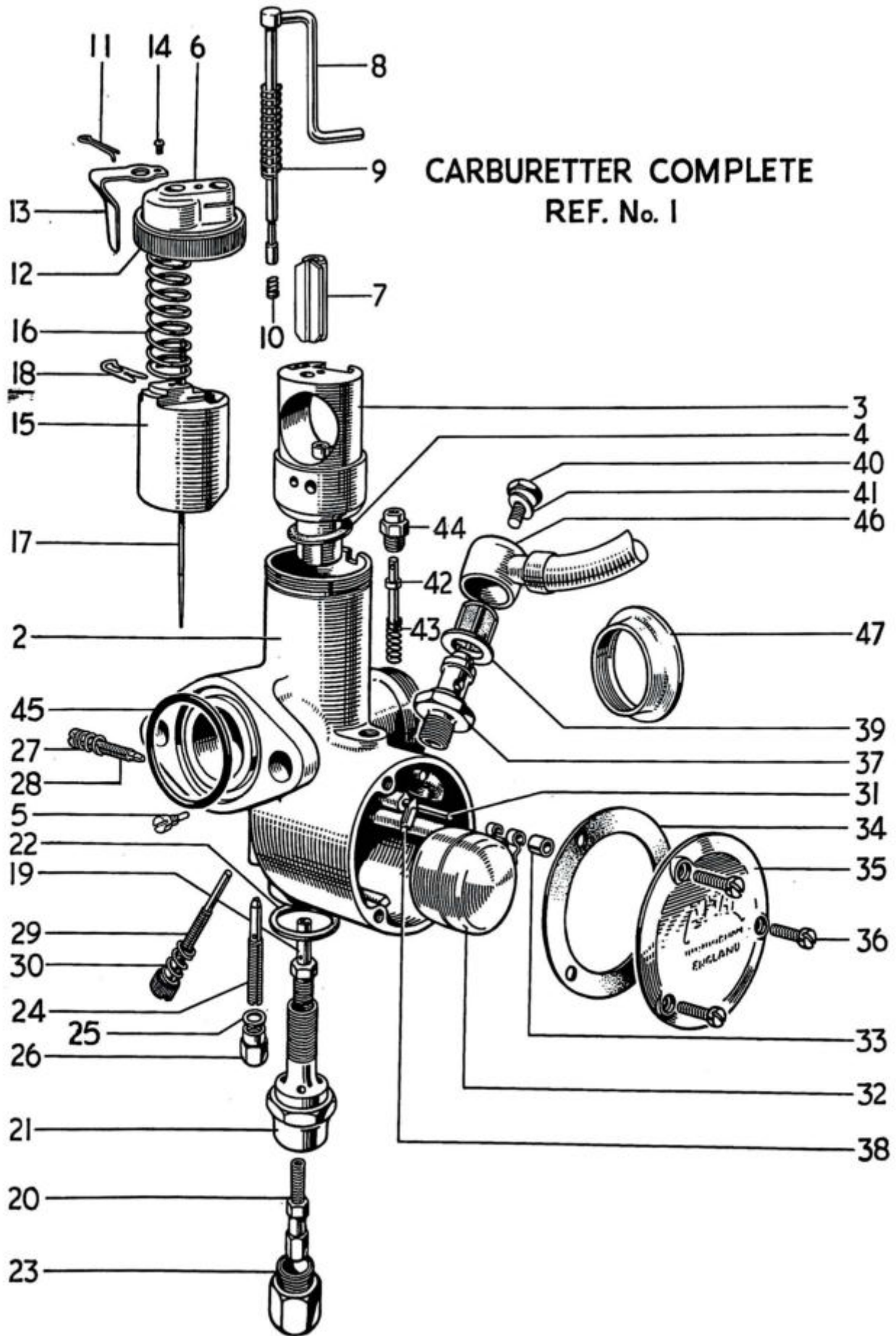

Fig. 29. CARBURETTER, T100A and T100SS

Ref. No.	Part No.	DESCRIPTION	QUANTITY	
			T100A	T100SS
CARBURETTER, T100A & T100SS				
1	376/273	CARBURETTER, 1 in. choke ...	1	1
2	376/002	Mixing chamber 1 in. choke ...	1	1
3	376/056	Jet block, 1 in. choke ...	1	1
4	376/067	Joint washer ...	1	1
5	376/070	Peg screw ...	1	1
6	376/158	Mixing chamber top ...	1	1
7	376/166	Air valve ...	1	1
8	376/182	Control rod and lever ...	1	1
9	376/109	Return spring ...	1	1
10	30/187	Air valve spring ...	1	1
11	30/064	Click spring ...	1	1
12	376/065	Mixing chamber cap ...	1	1
13	29/308	Spring ...	1	1
14	4/241	Screw ...	1	1
15	376/060	Throttle valve (3½ cutaway) ...	1	1
16	376/061	Throttle return spring ...	1	1
17	376/063	Needle (Type C) ...	1	1
18	4/230	Needle clip ...	1	1
19	376/072	Needle jet (.106) ...	1	1
20	376/100	Main jet (190) ...	1	1
21	376/073	Jet holder ...	1	1
22	376/074	Fibre washer ...	1	1
23	376/075	Cover nut ...	1	1
24	376/076	Pilot jet (25) ...	1	1
25	116/162	Fibre washer ...	1	1
26	376/095	Cover nut ...	1	1
27	332/017	Air adjusting screw ...	1	1
28	4/148	Spring ...	1	1
29	376/068	Throttle stop screw ...	1	1
30	376/069	Spring ...	1	1
31	376/085	Float spindle ...	1	1
32	376/083	Float ...	1	1
33	376/094	Bush ...	1	1
34	376/078	Joint washer ...	1	1
35	376/077	Cover ...	1	1
36	376/079	Screw ...	3	3
37	376/088	Needle seating ...	1	1
38	376/089	Needle ...	1	1
39	376/093	Filter ...	1	1
40	376/091	Bolt ...	1	1
41	376/092	Fibre washer ...	1	1
42	376/086	Tickler ...	1	1
43	376/087	Spring ...	1	1
44	343/011	Tickler body ...	1	1
45	244/1048	"O" ring seal ...	1	1
46	F4308	Petrol pipe ...	1	1
47	376/066	Air intake tube ...	A	A

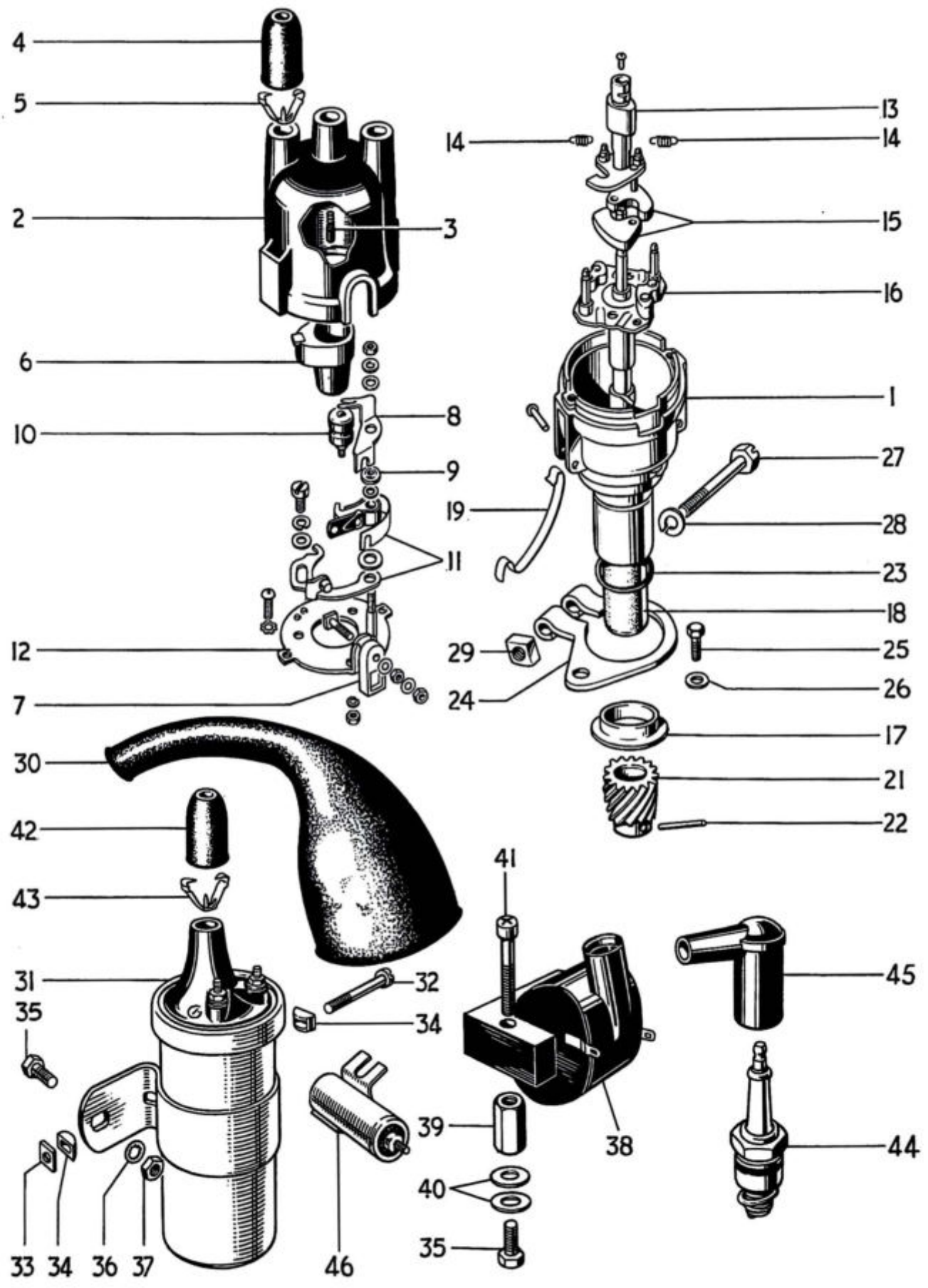

Fig. 30. DISTRIBUTOR, COIL AND SPARK PLUGS.

Ref. No.	Part No.	DESCRIPTION	3TA	5TA	T100A	T100SS
DISTRIBUTOR, COIL AND SPARK PLUGS						
1	40573	DISTRIBUTOR	1	-	-	-
1	40646	DISTRIBUTOR	-	1	-	1
1	†40710	DISTRIBUTOR	-	-	1	-
2	425049	CAP ASSEMBLY	1	1	1	1
3	404435	Brush and spring	1	1	1	1
4	421554	Rubber grommet	3	3	3	3
5	421863	Cable clip	3	3	3	3
6	423486	Rotor	1	1	1	1
7	423110	Shaped insulating bush	1	1	1	1
8	423108	Condenser connector	1	1	1	1
9	423109	Insulating bush	1	1	1	1
10	54410823	Condenser	1	1	1	1
11	425219	Contact set	1	1	1	1
12	423113	Base plate	1	1	1	1
13	424972	Cam	1	1	-	1
13	54412359	Cam	-	-	1	-
14	422655/S	Spring set	1	-	1	-
14	54410895/S	Spring set	-	1	-	1
15	421056/S	Weight set	1	1	1	1
16	424967	Shaft and action plate	1	1	1	1
17	424974	Thrust cup	1	1	1	1
18	423571	Bush	1	1	1	1
19	424158	Retaining clip	2	2	2	2
20	425243	Sundry parts set	1	1	1	1
21	E3729	Distributor drive pinion	1	1	1	1
22	404314	Securing pin	1	1	1	1
23	188639	Rubber "O" ring	1	1	1	1
24	E3825	Clamp plate	1	1	1	1
25	DS57	Bolt ($\frac{7}{8}$ in. U.H.)	1	1	1	1
26	S25-3	Plain washer	1	1	1	1
27	112917	Clamp bolt	1	1	1	1
28	185051	Spring washer	1	1	1	1
29	173857	Nut	1	1	1	1
30	E3863	Distributor sheath	-	-	1	1
31	45077	Ignition coil M.A.6.	1	1	-	1
32	100104	Clip screw	1	1	-	1
33	169160	Square nut	1	1	-	1
34	422369	"D" washer	2	2	-	2
35	DS57	Bolt ($\frac{7}{8}$ in. U.H.)	2	2	2	2
36	E1612	Serrated washer	2	2	2	2
37	F879	Nut	2	2	-	2
38	45112	Ignition coil. 2ET.	-	-	1	-
39	F4709	Mounting pillar	-	-	2	-
40	F4708	Plain washer	-	-	4	-
41	E3668	Screw ($\frac{1}{2}$ in. U.H.)	-	-	2	-
42	421554	Rubber grommet	1	1	1	1
43	421863	Cable clip	1	1	1	1
44		Sparking plug (Champion N4, K.L.G. FE75 or Lodge HLN)	2	2	2	2
45	D297	Plug cover and suppressor	2	2	2	2
45	D262	Plug cover	A	A	A	A
46	54441582	Condenser	-	-	1	-

†After engine No. H22430 use 5TA distributor

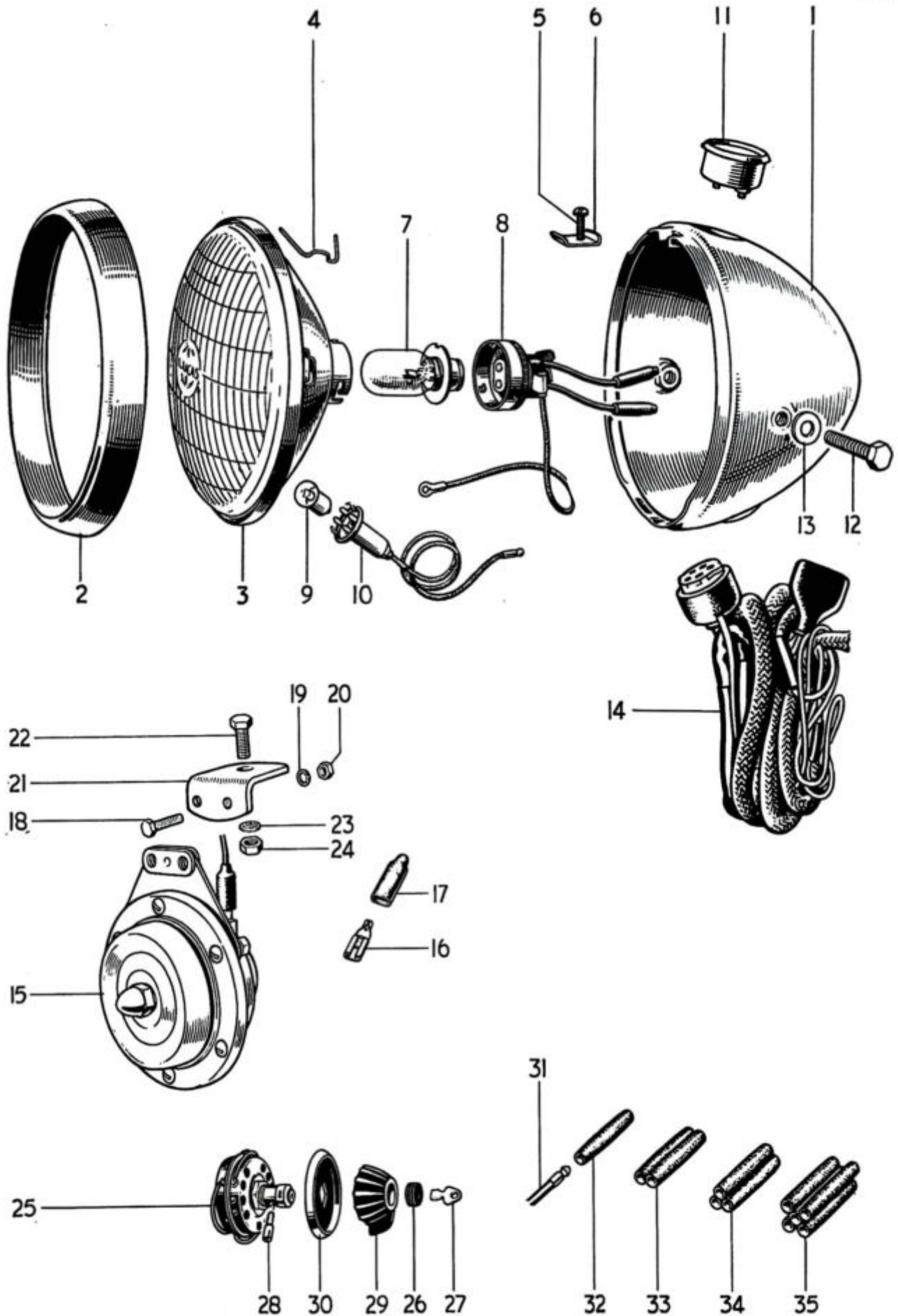

Fig. 31. T100SS HEADLAMP, WIRING HARNESS AND SWITCH

T100SS HEADLAMP, WIRING HARNESS AND SWITCH

											T100SS
1	58878	HEADLAMP COMPLETE (TYPE SS700P)	1
2	553248	Rim	1
3	516798	Light unit	1
4	594665	Fixing wire	6
5	144921	Screw	1
6	534296	Plate	1
7	312	Bulb (30/24W Vert. dip pre focus)	1
8	554602	Adaptor	1
9	988	Bulb (3W M.C.C.)	1
10	554710	Pilot bulbholder	1
11	36296	Ammeter (Type 2AR)	1
12	112201	Bolt	2
13	137499	Plain washer	2
14	54094363	Wiring harness	1
15	70163	Horn (Type 8H)	1
16	54942078	Lucar connector	2
17	54190042	Insulating cover	2
18	T1076	Bolt ($\frac{3}{8}$ in. U.H.)	2
19	GS299	Serrated washer	2
20	F3799	Nut	2
21	F5086	Horn bracket	1
22	F1369	Bolt ($\frac{7}{16}$ in. U.H.)	1
23	E1612	Serrated washer	1
24	F879	Nut	1
25	31443	LIGHTING AND IGNITION SWITCH (PRS8)	1
26	318323	Grommet	1
27	318341	Key	1
28	319333	Screw	1
29	318346	Knob	1
30	318343	Index plate	1
31	900269	Snap connector terminal	A
32	900288	Single snap connector	A
33	850641	Double snap connector	A
34	850844	Triple snap connector	A
35	850832	Quintuple snap connector	A

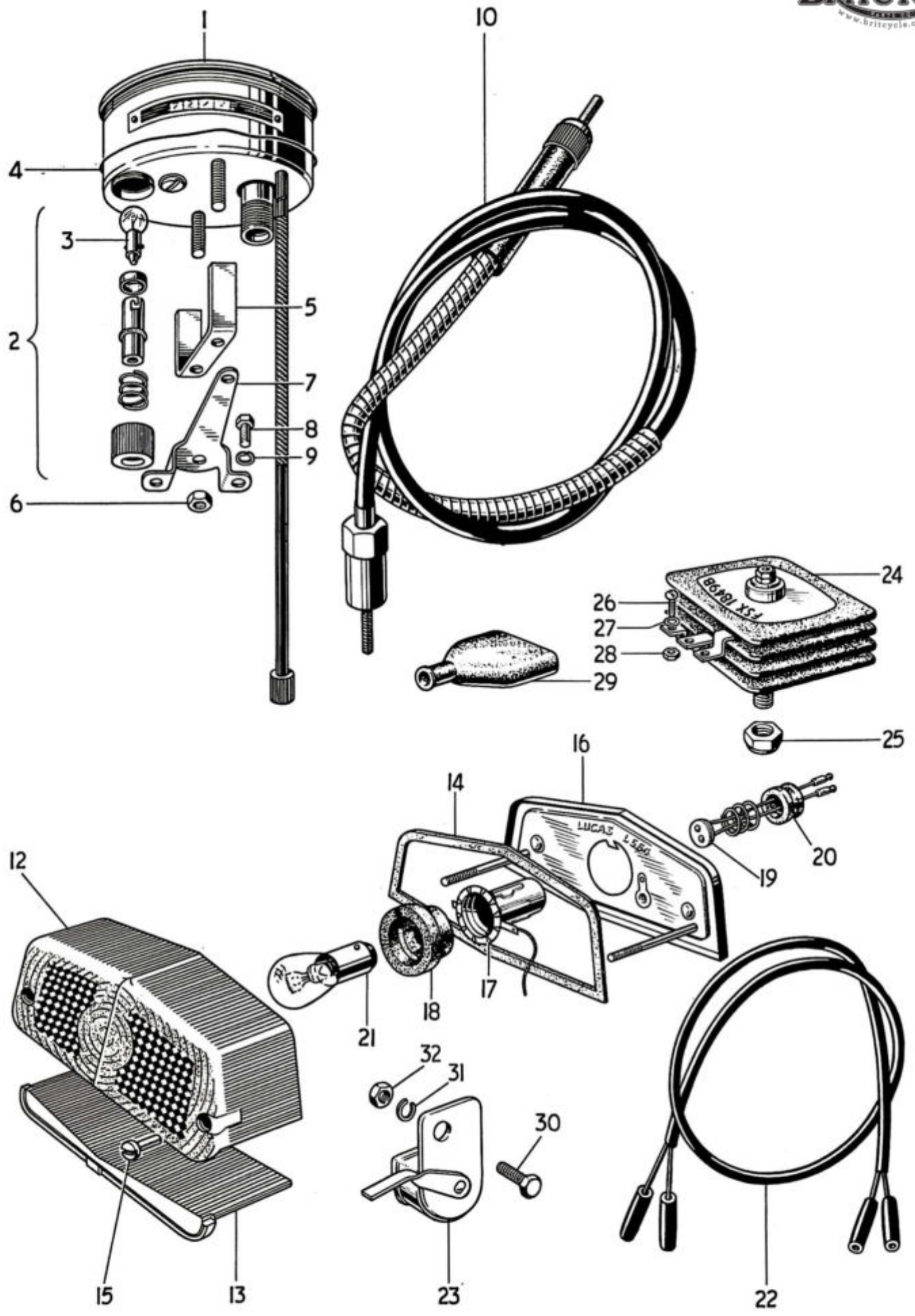

Fig. 32. SPEEDOMETER, STOP AND TAIL LAMP AND RECTIFIER

SPEEDOMETER, STOP AND TAIL LAMP AND RECTIFIER

									3TA	5TA	T100A	T100SS
1	SC3304/11	Speedometer Head M.P.H.	1	1	1	-
1	SC3304/18	Speedometer Head K.P.H.	A	A	A	-
1	SC5301/03	Speedometer Head M.P.H.	-	-	-	1
1	SC5301/12	Speedometer Head K.P.H.	-	-	-	A
2	P53279/1	BULB HOLDER c/w BULB	1	1	1	1
3	P52305	Bulb...	1	1	1	1
4	P22469	Rubber ring	1	1	1	-
5	25578/2	Clamp bar	1	1	1	-
6	N1253	Nut	1	2	2	2
7	DS40	Bracket	-	-	-	1
8	DS57	Bolt ($\frac{7}{8}$ in. U.H.)	-	-	-	2
9	S26-2	Spring washer	-	-	-	2
10	D356	Speedometer drive cable (58 in. long)	1	1	1	1
11	53432	STOP AND TAIL LAMP (Type 564)	1	1	1	1
12	573839	Lens...	1	1	1	1
13	575200	Window	1	1	1	1
14	575208	Lens seating gasket	1	1	1	1
15	575219	Sleeve nut	2	2	2	2
16	576002	Base assembly	1	1	1	1
17	575209	Bulbholder	1	1	1	1
18	575207	Grommet	1	1	1	1
19	573828	Contact assembly	1	1	1	1
20	573825	Grommet	1	1	1	1
21	384	Bulb (6/18W offset pin)	1	1	1	1
22	838604	Stop and tail lamp lead	1	1	1	1
23	34381	Stop lamp switch (6SA)	1	1	1	1
24	47132	Rectifier	1	1	1	1
25	F3600	Self-locking nut	1	1	1	1
26	F4813	Screw ($\frac{7}{8}$ in. U.H.)	3	3	3	3
27	F4844	Crinkle washer	3	3	3	3
28	H919	Nut	3	3	3	3
29	862566	Grommet	1	1	1	1
30	54948333	Brake Switch lead (not illustrated)	1	1	1	1