

TRIUMPH

**REPLACEMENT
PARTS CATALOGUE**

No. 6

★

**TWENTY-ONE (3TA)
SPEED TWIN (5TA) TIGER 90 (T90)
TIGER 100 (T100S/S)
FROM ENGINE No. H35987**

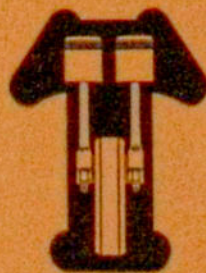



REPLACEMENT PARTS CATALOGUE No. 6

“C” RANGE MODELS
TWENTY-ONE (3TA)
SPEED TWIN (5TA)
TIGER 90 (T90)
TIGER 100 (T100 S/S)

from Engine No. H 35987

September 1964

TRIUMPH ENGINEERING COMPANY LIMITED
MERIDEN WORKS · ALLESLEY · COVENTRY · ENGLAND
TELEPHONE MERIDEN 331 TELEGRAMS “TRUSTY COVENTRY”

TRIUMPH GUARANTEE

1. In this Guarantee the word "machine" refers to the motor cycle, scooter, motor-cycle combination or sidecar as the case may be, purchased by the Purchaser.
2. In order to obtain the benefit of this Guarantee, the Purchaser must have correctly completed the registration form and returned it to us within fourteen days of the purchase.
3. We will supply, free of charge, a new part in exchange for, or, if we consider repair sufficient, will repair free of charge any part proved within six months of the date of purchase of any new machine, (3 months overseas) or within three months of its renewal or repair in the case of a part already renewed or repaired, to be defective by reason of our faulty workmanship or materials. We do not undertake to bear the cost of fitting such new or repaired part or accessory.
4. Any part considered to be defective must be sent to our Works, carriage paid, accompanied by the following information:—
 - (a) Name of purchaser and his address;
 - (b) Date of purchase of machine;
 - (c) Name of dealer from whom the purchase was made;
 - (d) Engine number and model
5. This Guarantee shall not extend to defect or damage appearing after misuse, neglect, abnormal stress or strain, or the incorporation or affixing of unsuitable attachments or parts and in particular:—
 - (a) Hiring out;
 - (b) Racing and Competitions;
 - (c) Adaptation or alteration of any part or parts after leaving our Works;
 - (d) The attaching of a sidecar in a manner not approved by us or to an unsuitable motor-cycle.

This Guarantee shall not extend to machines whose trade mark, name or manufacturing number has been altered or removed, or in which has been used any part not supplied or approved by us, or to tyres, saddles, chains, speedometers, revolution counters and electrical equipment or to parts supplied to the order of the Purchaser and different from our standard specification.

6. Our liability and that of our dealer who sells the machine, shall be limited to that set out in this guarantee, and no other claims for consequential damage or injury to person or property, shall be admissible. All other conditions and warranties statutory or otherwise and whether express or implied are hereby excluded and no guarantee other than that expressly herein contained applies to the machine to which this Guarantee relates or any accessory or part thereof.
7. We reserve the right to modify or deviate from the Published Specification without notice.

REPAIRS GUARANTEE

1. Whilst the highest standard of workmanship and materials is aimed at, we cannot accept liability for any defects appearing more than three months after the machine, assembly or component has left our Works after being repaired.
2. We will repair or replace at our option free of charge any defective work, materials or parts relating to the repairs carried out by us appearing within that time but shall not be under any further, or other liability for any other loss or damage whether direct or consequential and our liability shall be limited to the cost of so making good. We do not undertake to bear the cost of fitting any replacement or repaired part.
3. We do not accept liability in respect of parts of proprietary manufacture, e.g. tyres, saddles, chains speedometers, revolution counters and electrical equipment which may be used by us in effecting a repair. All other conditions and warranties statutory or otherwise express or implied are hereby excluded.

TRIUMPH SPARES

HOW TO ORDER. Every part is indicated by number, and this should be quoted together with the description. In order to assist customers, dimensions have been given in many cases where parts are similar. Parts where possible have been listed in order of assembly and a number of the illustrations show the assembly order also. With these aids there should be no difficulty in identifying the parts you require. **Always head your order with the engine number, stamped on the left side of the crank case underneath the cylinder flange, together with the prefix letters.**

WHERE TO OBTAIN. Triumph Spare Parts can only be obtained from an authorised Triumph Dealer, and we recommend our customers to place their orders with the Triumph Dealer in their district. When parts not usually asked for are required, and for which the Dealer may have to write or obtain specially, the postage or carriage incurred becomes payable.

Triumph Spares are not supplied to private owners direct from the factory. If difficulty is experienced in obtaining the required parts, the matter should be taken up directly with the Triumph Spares Department.

Customers are warned against the risk incurred by purchasing parts that are not of genuine Triumph manufacture. This risk is eliminated if parts are ordered as instructed from recognised Dealers.

PATTERNS AND PARTS FOR REPAIR. It is not necessary to send patterns if the part number is quoted. The sending of patterns often delays the order as parcel post or rail takes longer than letter post.

Parts sent to Coventry for repair, replacement, or as patterns should bear the sender's name and address and clear instructions should accompany the parts. In your own interest send a copy of the advice note under separate cover. All parts must be forwarded carriage paid and care should be taken to ensure that all remittances are sent separately and not enclosed with the parts. Fragile units such as cylinders, etc., should always be boxed to avoid damage in transit. Complete machines should have all fitments such as windscreens, driving mirrors, tools, etc., removed by the sender before despatch, as it is impossible for us to accept responsibility in the event of loss in transit. We are always pleased to give estimates for overhauling and repairs, but should an estimate not be accepted, a charge will be made covering cost of dismantling and re-assembling, if carried out.

Communications relating to Parts should be addressed to the SPARES DEPARTMENT and for repairs, guarantee claims and technical advice to the SERVICE DEPARTMENT, Triumph Engineering Co. Ltd., Meriden Works, Allesley, Coventry. In order to facilitate quick reference, the quoting of any number, invoice number or reference from previous communications is essential. Accessories not of our manufacture should be sent direct to the actual makers, whose names and addresses appear below.

PROPRIETARY GROUP

Ancillary equipment which is fitted to our motor cycles is of the highest quality and is guaranteed by the manufacturer and not by ourselves. Any repairs or claims should be made to the actual makers or their local agents who will always give owners every possible assistance. The following are the addresses of the various manufacturers:—

CARBURETTERS
Messrs. Amal Ltd.,
Holdford Rd., Witton, Birmingham 6.

SPARKING PLUGS
Champion Sparking Plug Co. Ltd.,
Feltham, Middlesex.

CHAINS
Renold Chains Ltd.,
Wythenshawe, Manchester.

SPEEDOMETERS
Messrs. Smiths Motor Accessories Ltd.,
Cricklewood Works, London, N.W.2.

ELECTRICAL EQUIPMENT
Messrs J. Lucas Ltd.,
Gt. Hampton St., Birmingham, 18.

SUSPENSION UNITS
Messrs. Girling Ltd.,
Kings Road, Tyseley, Birmingham, 11.

TYRES
Dunlop Rubber Co. Ltd.,
Fort Dunlop,
Birmingham, 24.

ILLUSTRATION INDEX

<i>Fig. No.</i>	<i>Description</i>	<i>Page No.</i>
1	CRANKSHAFT AND CONNECTING RODS	12
2	CRANKCASE	14
3	OIL PUMP, RELEASE VALVE AND INLET MANIFOLD	16
4	CYLINDER BLOCK AND HEAD, 3TA AND T90	18, 20
5	CYLINDER BLOCK AND HEAD 5TA AND T100SS	22
6	TIMING COVER, CONTACT BREAKER AND COILS	24
7	GEARBOX SHAFTS, BEARINGS AND INNER COVER	26
8	GEARBOX OUTER COVER AND LEVERS	28
9	CLUTCH	30
10	CHAINCASE AND CHAINS	32
11	ENGINE FITTINGS AND EXHAUST SYSTEM	34
12	FRAME	36
13	SWINGING FORK, SUSPENSION UNITS AND CHAINGUARD	38
14	TELESCOPIC FRONT FORK, 3TA AND 5TA	40
15	NACELLE, HEADLAMP AND SWITCHES	42
16	TELESCOPIC FRONT FORK, T90 AND T100SS	44
17	FRONT WHEEL	46
18	REAR WHEEL	48
19	QUICKLY DETACHABLE REAR WHEEL	50
20	MUDGUARDS	52
21	PANELS AND TWINSEAT	54
22	PETROL TANK	56
23	OIL TANK	58
24	BATTERY, TOOLKIT AND AIR FILTER	60
25	HANDLEBARS AND CONTROL LEVERS	62
26	CONTROL CABLES	64
27	CARBURETTER, 3TA AND 5TA	66
28	CARBURETTER, T90 AND T100SS	68
29	T90 AND T100SS HEADLAMP, WIRING HARNESS AND SWITCHES	70
30	SPEEDOMETER, TACHOMETER AND TAIL LAMP	72

INDEX

	<i>Page</i>		<i>Page</i>
AIR FILTER	61	MANIFOLD	17
ALTERNATOR	13	MUDGUARDS	53
BATTERY CARRIER	61	NACELLE	43
CARBURETTER	67, 69	OIL PUMP	17
CARTON PACKS	10	OIL TANK	59
CENTRE STAND	37	PETROL TANK	57
CHAINCASE	33	PILLION FOOTRESTS	37
CHAINS	33	PISTONS	13
CLUTCH	31	PROP STAND	37
COIL	25	Q.D. REAR WHEEL	51
CONTACT BREAKER	25	REAR PANELS	55
CONTROL CABLES	65	REAR WHEEL	49
CONTROL LEVERS	63	RECTIFIER	43, 71
CRANKCASE	15	SILENCERS	35
CRANKSHAFT	13	SPARK PLUGS	25
CYLINDER HEAD	19, 23	SPEEDOMETER	73
ENGINE PLATES	35	STEERING RACES	37
EXHAUST PIPES	35	SUSPENSION UNITS	39
FOOTRESTS	37	SWITCHES	43
FRONT FORKS	41, 45	TIMING GEARS	13
FRONT WHEEL	47	TOOLKIT	61
GASKET SETS	11	TWINSEAT	55
GEARBOX	27, 29	VALVES	19, 23
HANDLEBARS	63	WIRING HARNESS	43, 71
HORN	43		

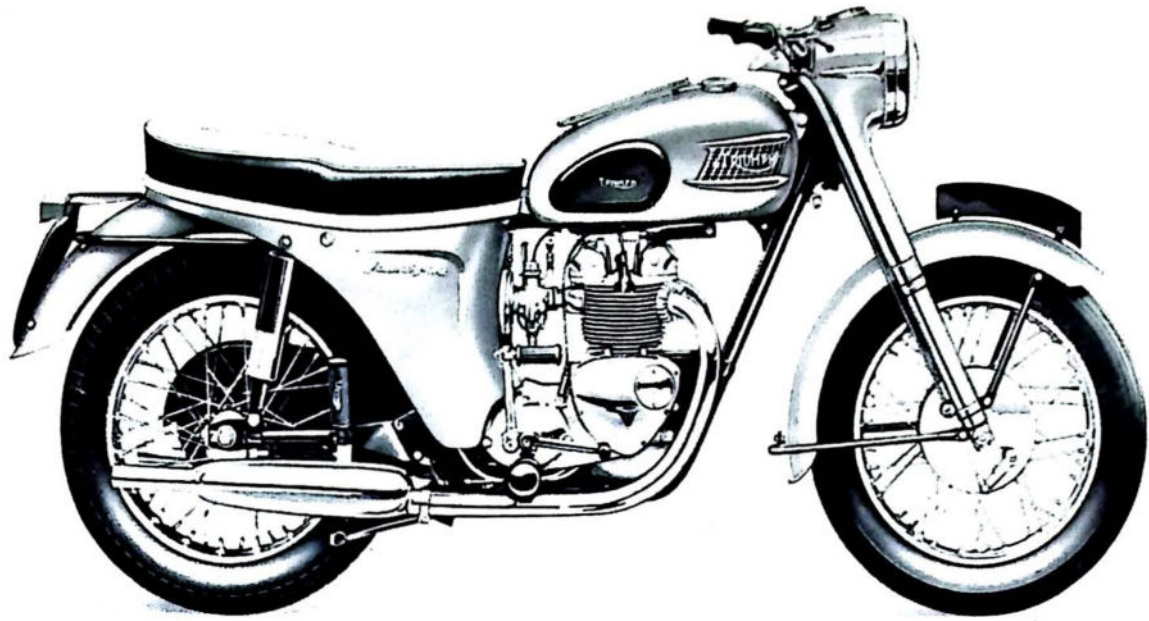

TWENTY-ONE (3TA) TECHNICAL DATA

Bore and stroke		58.25 x 65.5 mm. 2.292 in. x 2.578 ins.
Capacity		348 c.c. (21.23 cu. ins.).
Compression Ratio		7.5 : 1
Sparking Plugs		Champion N4
Carburettor		Amal Monobloc 375
	Main Jet	100
	Needle Jet	.106
	Needle	Type B
	Throttle Valve	375/3½
	Pilot Jet	25
Gearbox Sprocket		18 teeth
Chains	Front	¾ in. Duplex x 78 links
	Rear	⅝ in. x ⅝ in. x 102 links
Capacities	Fuel Tank	3½ galls. (16 litres)
	Oil Tank	5 pints (2.8 litres)
	Gearbox	2/3 pint (375 c.c.)
	Primary Chaincase	½ pint (300 c.c.)
	Front Forks (each leg)	⅓ pint (190 c.c.)
Brakes	Front and Rear, diameter	7 in. (17.78 cm.)
Tyre Size	Front	3.25 x 17
	Rear	3.25 x 17

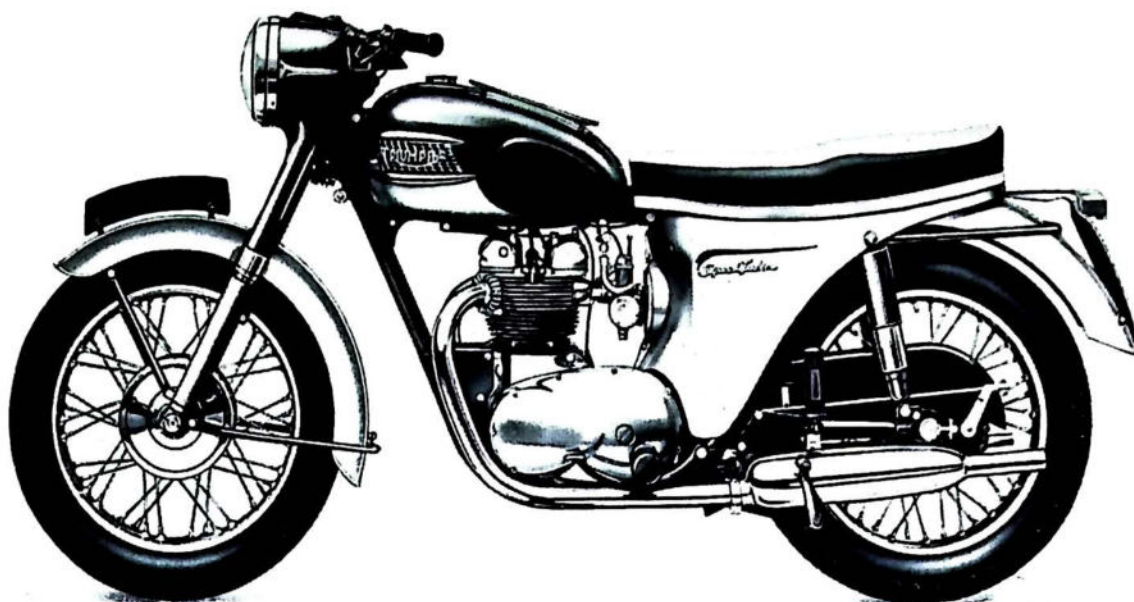

SPEED TWIN (5TA) TECHNICAL DATA

Bore and Stroke		69 x 65.5 mm. 2.716 x 2.578 ins.
Capacity		490 c.c. (29.8 cu. ins.)
Compression Ratio		7 : 1
Sparking Plugs		Champion N4
Carburetter		Amal Monobloc 375
	Main Jet	160
	Needle Jet	.105
	Needle	Type B
	Throttle Valve	375/3
	Pilot Jet	25
Gearbox Sprocket		20 teeth
Chains	Front	$\frac{3}{8}$ in. Duplex x 78 links
	Rear	$\frac{5}{8}$ in. x $\frac{3}{8}$ in. x 104 links
Capacities	Fuel Tank	3½ galls. (16 litres)
	Oil Tank	5 pints (2.8 litres)
	Gearbox	2/3 pint (375 c.c.)
	Primary Chaincase	½ pint (300 c.c.)
	Front Forks (each leg)	$\frac{1}{8}$ pint (190 c.c.)
Brakes	Front and Rear, diameter	7 in. (17.78 cm.)
Tyre Size	Front	3.25 x 17
	Rear	3.50 x 17



TIGER 90 (T90) TECHNICAL DATA

Bore and Stroke		58.25 x 65.5 mm. 2.292 x 2.578 ins.
Capacity		348 c.c. (21.23 cu. ins.)
Compression Ratio		9 : 1
Sparking Plugs		Champion N4
Carburetter		Amal Monobloc
	Main Jet	180
	Needle Jet	.106
	Needle	Type C
	Throttle Valve	376/3½
	Pilot Jet	20
Gearbox Sprocket		17 teeth
Chains	Front	¾ in. Duplex x 78 links
	Rear	¾ in. x ¾ in. x 102 links
Capacities	Fuel Tank	3½ galls. (16 litres)
	Oil Tank	5 pints (2.8 litres)
	Gearbox	2/3 pint (375 c.c.)
	Primary Chaincase	½ pint (300 c.c.)
	Front Forks (each leg)	¾ pint (190 c.c.)
Brakes	Front and Rear, diameter	7 in. (17.78 cm.)
Tyre Size	Front	3.25 x 18
	Rear	3.50 x 18

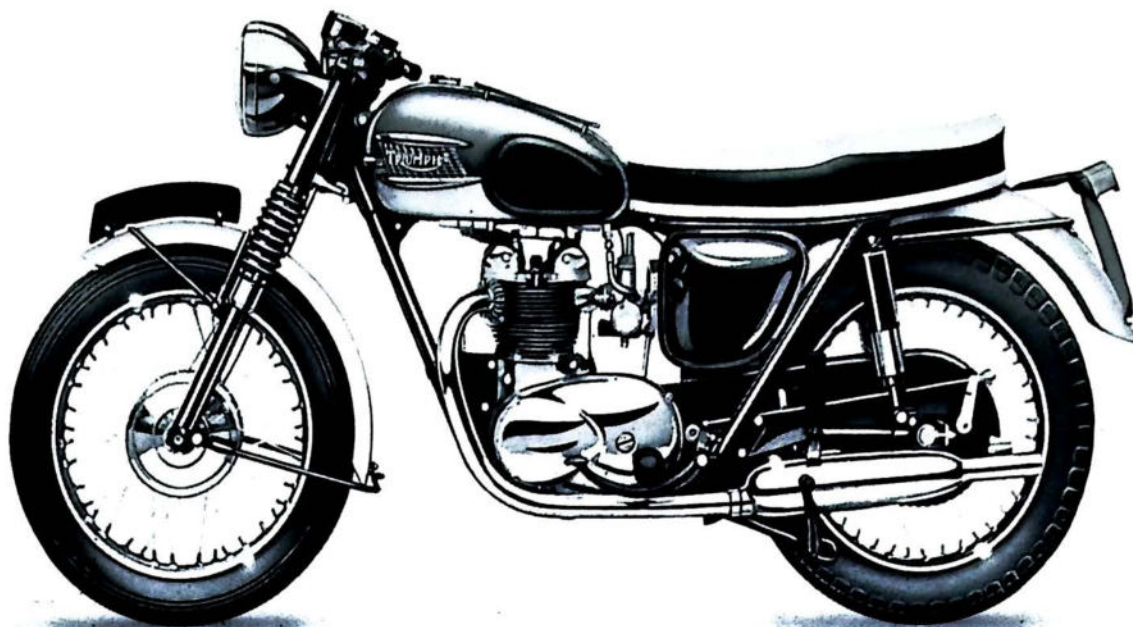

TIGER 100 (T100SS) TECHNICAL DATA

Bore and Stroke		69 x 65.5 mm. 2.716 x 2.578 ins.
Capacity		490 c.c. (29.8 cu. ins.)
Compression Ratio		9 : 1
Sparking Plugs		Champion N4
Carburettor		Amal Monobloc
	Main Jet	190
	Needle Jet	.106
	Needle	Type C
	Throttle Valve	376/3½
	Pilot Jet	25
Gearbox Sprocket		18 teeth
Chains	Front	¾ in. Duplex x 78 links
	Rear	5/8 in. x ¾ in. x 102 links
Capacities	Fuel Tank	3½ galls. (16 litres)
	Oil Tank	5 pints (2.8 litres)
	Gearbox	2/3 pint (375 c.c.)
	Primary Chaincase	½ pint (300 c.c.)
	Front Forks (each leg)	⅓ pint (190 c.c.)
Brakes	Front and Rear, diameter	7 in. (17.18 cm.)
Tyre Size	Front	3.25 x 18
	Rear	3.50 x 18

CARTON PACK LIST

The following sub-assemblies are supplied in carton packs under the C.P. part number stated. The contents of these carton packs are preserved and will not deteriorate under adverse conditions.

<i>Part No.</i>			<i>Contents</i>
Brake Lining C.P. 38/AM2	2	NW243	Brake Lining
	16	W129	Rivet
Steering Races C.P. 167	1	H1110	Cone
	1	H1140	Cone and dust cover
	2	H1130	Cup
	48	S70-4	Steel balls (3/16 in. diam.)
Pistons (350 c.c.) C.P. 164	1	E3689	Piston C.R. 7.5 : 1
	1	E3691	Compression ring (plain)
	1	E3690	Compression ring (taper)
	1	E3692	Oil control ring
	1	E1750	Gudgeon pin
	2	E1767	Circlips
C.P. 164 is also available in 0.010 in., 0.020 in. and 0.040 in. oversizes.			
C.P. 198	1	E4670	Piston C.R. 9 : 1
	2	E3690	Compression ring (taper)
	1	E3692	Oil control ring
	1	E1750	Gudgeon pin
	2	E1767	Circlips
C.P. 198 is also available in 0.010 in., 0.020 in. and 0.040 in. oversizes.			
Piston Rings (350 c.c.) C.P. 165	2	E3691	Compression ring (plain)
	2	E3690	Compression ring (taper)
	2	E3692	Oil control ring
C.P. 165 is also available in 0.010 in., 0.020 in. and 0.040 in. oversizes.			
Pistons (500 c.c.) C.P. 174	1	E4004	Piston C.R. 7 : 1
	2	E3829	Compression ring (taper)
	1	E3831	Oil control ring
	1	WE203E	Gudgeon pin
	2	WE479	Circlips
C.P. 174 is also available in 0.010 in. and 0.020 in. oversizes.			
C.P. 179	1	E4021	Piston C.R. 9 : 1
	2	E3829	Compression ring (taper)
	1	E3831	Oil control ring
	1	WE203E	Gudgeon pin
	2	WE479	Circlips
C.P. 179 is also available in 0.010 in. and 0.020 in. oversizes.			
Piston Rings (500 c.c.) C.P. 175	4	E3829	Compression ring (taper)
	2	E3831	Oil control ring
C.P. 175 is also available in 0.010 in. and 0.020 in. oversizes.			

CARTON PACK LIST—continued

<i>Part No.</i>	<i>Contents</i>	
C.P. 180	4 E4135 2 E4136	Compression ring (taper) Oil control rings
C.P. 180 can only be fitted to E4021 Piston body, and should only be used for high-performance work.		
Valve Guides		
C.P. 170	4 E3208 4 E3209	Valve guides Valve guides circlip
Valves (3TA)		
C.P. 166	2 E3738 2 E3739	Inlet valve Exhaust valve
Valve Springs (3TA)		
C.P. 171	4 E3942 4 E3741	Inner valve spring Outer valve spring
Valves (500 c.c.)		
C.P. 176	2 E4012 2 E4013	Inlet valve Exhaust valve
Valve Springs (T90 & 500 c.c.)		
C.P. 177	4 E4010 4 E4011	Inner valve spring Outer valve spring

De-coke Gasket Set	All models	D/GS 6
--------------------	------------	--------

PLEASE NOTE

THROUGHOUT THIS LIST, ASSEMBLIES ARE PRINTED IN CAPITALS AND THE COMPONENTS INCLUDED IN THAT ASSEMBLY ARE INDENTED IN THE DESCRIPTION COLUMN, REVERTING TO THE ORIGINAL ALIGNMENT WHEN THE ASSEMBLY IS COMPLETE. TO ORDER THE COMPLETE ASSEMBLY IT IS NECESSARY ONLY TO QUOTE THE ASSEMBLY NUMBER. ANY COMPONENT PARTS LISTED MAY ALSO BE OBTAINED SEPARATELY IF REQUIRED.

SPECIAL WORKSHOP TOOLS

A COMPLETE LIST OF WORKSHOP TOOLS CAN BE MADE AVAILABLE BY EITHER CONTACTING YOUR DEALER OR APPLYING DIRECT TO THE TRIUMPH SERVICE DEPARTMENT. IN MOST CASES THESE TOOLS ARE VERY COSTLY AS THEY ARE MADE ENTIRELY FOR WORKSHOP USE, AND THEREFORE, IT IS NOT RECOMMENDED THAT THE PRIVATE OWNER PURCHASES THE TOOLS IN ORDER TO AID SERVICING THE MACHINE ONCE OR TWICE ONLY. IN THESE CIRCUMSTANCES IT IS FAR MORE ECONOMICAL TO GET IN TOUCH WITH A RECOGNISED DEALER.

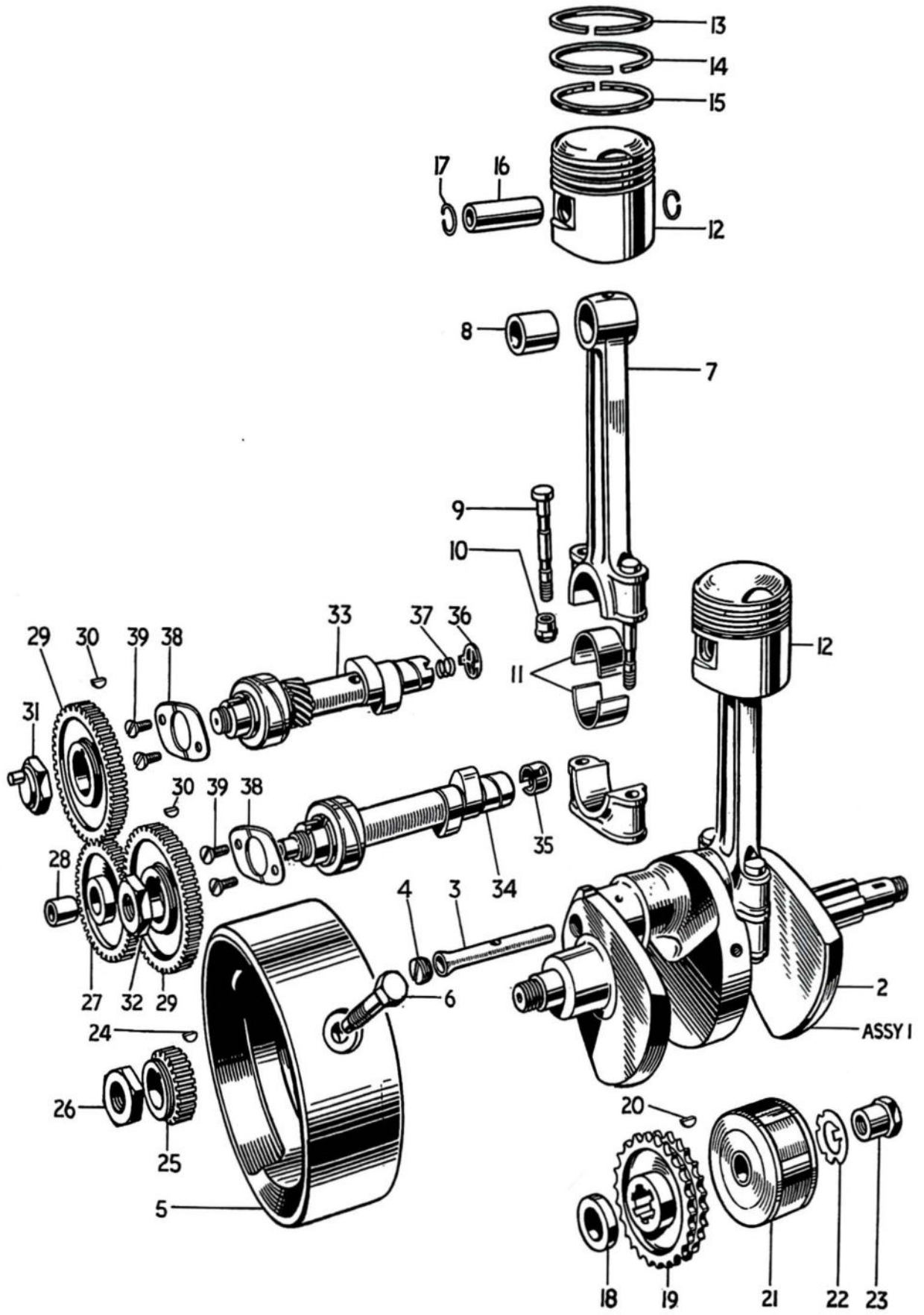

Fig. 1. CRANKSHAFT AND CONNECTING RODS

CRANKSHAFT AND CONNECTING RODS

Ref. No.	Part No.	DESCRIPTION	3TA	5TA	T90	T100SS
1	E5869	CRANKSHAFT AND FLYWHEEL ASSEMBLY ...	1	1	1	1
2	E3998	Crankshaft ...	1	1	1	1
3	E3999	Oil tube ...	1	1	1	1
4	E3711	Screwed plug ...	1	1	1	1
5	E5870	Flywheel ...	1	1	1	1
6	*E3713	Flywheel bolt ...	3	3	3	3
7	E3702	CONNECTING ROD ...	2	-	2	-
7	E4001	CONNECTING ROD... ...	-	2	-	2
8	E1762	Small end bush ...	2	-	2	-
8	E4003	Small end bush ...	-	2	-	2
9	E3705	Connecting rod bolt ...	2	2	2	2
10	E2922	Self-locking nut ...	2	2	2	2
11	E3706	Big end bearing ...	4	4	4	4
12	CP 164	PISTON COMPLETE C.R. 7.5:1 ...	2	-	-	-
12	CP 174	PISTON COMPLETE C.R. 7:1 ...	-	2	-	-
12	CP 198	PISTON COMPLETE C.R. 9:1 ...	-	-	2	-
12	CP 179	PISTON COMPLETE C.R. 9:1 ...	-	-	-	2
13	E3691	Plain compression ring ...	2	-	-	-
13	E3829	Taper compression ring ...	-	2	-	2
14	E3690	Taper compression ring ...	2	-	4	-
14	E3829	Taper compression ring ...	-	2	-	2
15	E3692	Oil control ring ...	2	-	2	-
15	E3831	Oil control ring ...	-	2	-	2
16	E1750	Gudgeon pin ...	2	-	2	-
16	WE 203E	Gudgeon pin ...	-	2	-	2
17	E1767	Circlip ...	4	-	2	-
17	WE 479	Circlip ...	-	4	-	4
18	E4006	Distance collar ...	1	1	1	1
19	E4141	Engine sprocket, 26T Duplex ...	1	1	1	1
20	E3851	Rotor key ...	1	1	1	1
21	54213901	Rotor, type RM 19 ...	1	1	1	1
22	E3975	Tab washer ...	1	1	1	1
23	E3735	Nut ...	1	1	1	1
24	E1580	Key ...	1	1	1	1
25	E1771	Timing pinion ...	1	1	1	1
26	E398	Nut ...	1	1	1	1
27	E2202	INTERMEDIATE WHEEL ...	1	1	1	1
28	E400	Bush ...	1	1	1	1
29	E1486A	Camshaft wheel... ...	2	2	2	2
30	E1558	Camshaft key ...	2	2	2	2
31	E1463	Inlet camshaft nut ...	1	1	1	1
32	E4563	Exhaust camshaft nut ...	1	1	1	1
33	E3838	Inlet camshaft ...	1	1	-	-
33	E4678	Inlet camshaft ...	-	-	1	1
34	E5341	Exhaust camshaft ...	1	1	-	-
34	E4786	EXHAUST CAMSHAFT ...	-	-	1	1
35	E4700	Tachometer drive thimble ...	-	-	1	1
36	E5316	Rotary breather valve ...	1	1	1	1
37	E2256	Breather valve spring ...	1	1	1	1
38	E3727	Retaining plate ...	2	2	2	2
39	E3728	Screw (15/32 In. U.H.) ...	4	4	4	4

*Use D524 Loctite sealant

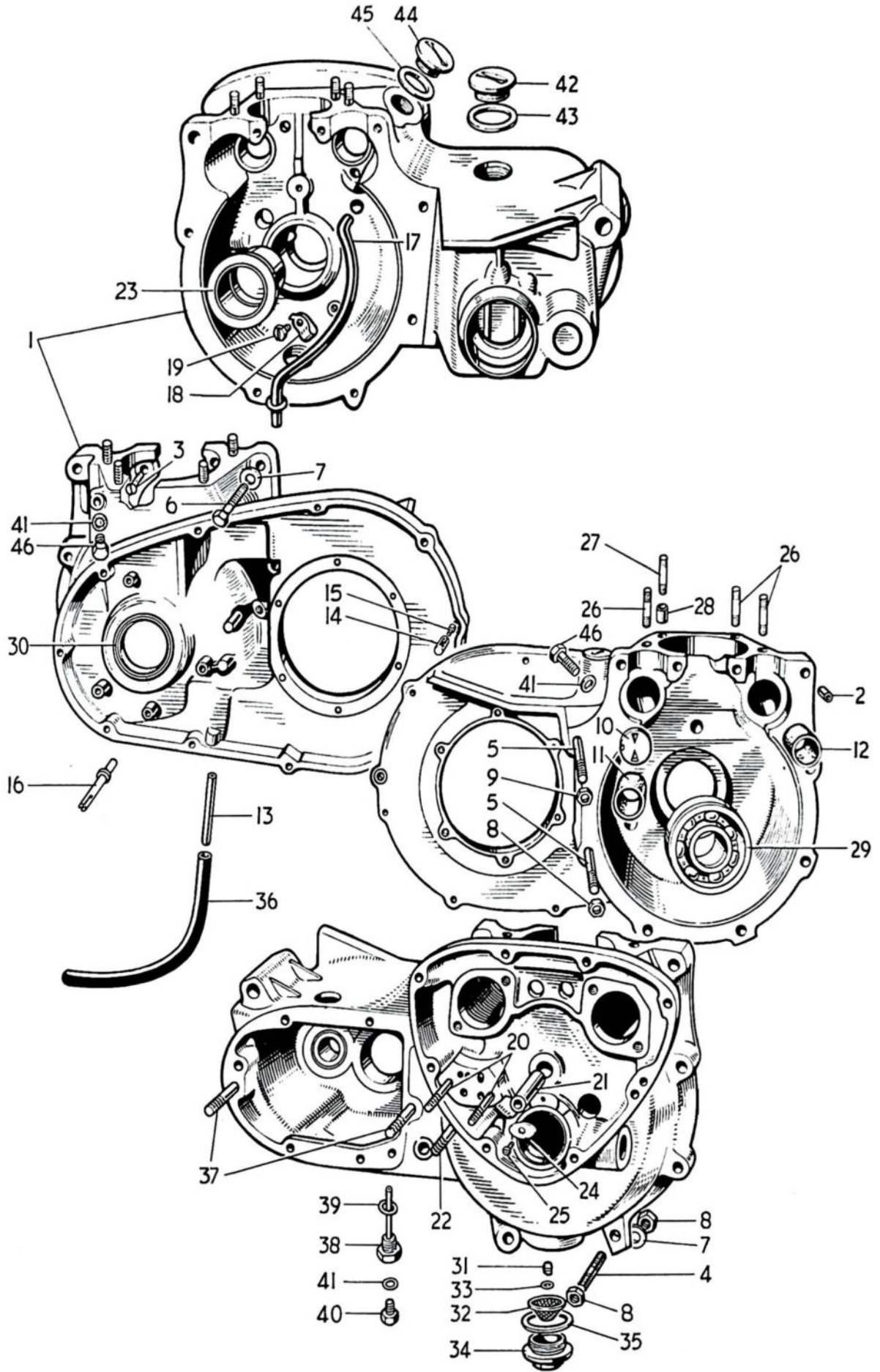

Fig. 2. CRANKCASE

Ref. No.	Part No.	DESCRIPTION	3TA	5TA	T90	T100SS
CRANKCASE						
1	E5868/4645	CRANKCASE c/w STUDS AND RIGHT MAIN BEARING	1	1	1	1
2	E3716	Hollow dowel	1	1	1	1
3	E3859	Screw (21/32 in. U.H.)	2	2	2	2
4	E3804	Stud (3 in. O.A.)	1	1	1	1
5	E3803	Stud (3 3/4 in. U.H.)	2	2	2	2
6	E3799	Bolt (1 5/8 in. U.H.)	1	1	1	1
7	S25-3	Plain washer	3	3	3	3
8	S1-51	Nut	3	3	3	3
9	E1310	Nut	1	1	1	1
10	E3822	Breather disc	1	1	1	1
11	E3824	Inlet camshaft bush	1	1	1	1
12	E3823	Exhaust camshaft bush	1	1	1	1
13	E2724	Breather pipe	1	1	1	1
14	E3884	Chain oiler tube	1	1	1	1
15	E3885	Chain oiler jet	1	1	1	1
16	E4147	Chain tensioner abutment	1	1	1	1
17	E3719	Oil scavenge pipe	1	1	1	1
18	E1509	Clip	1	1	1	1
19	E1645	Screw (17/64 in. U.H.)	1	1	1	1
20	E3718	Oil pump stud (1 1/8 in. O.A.)	2	2	2	2
21	E375	Intermediate wheel spindle	1	1	1	1
22	E3717	Oil pipes stud (1 1/2 in. O.A.)	1	1	1	1
23	E4322	Right main bearing	1	1	1	1
24	E4139	Locating plate	1	1	1	1
25	E4140	Self-tapping screw	1	1	1	1
26	E3820	Cylinder stud (1 1/2 in. O.A.)	6	6	6	6
27	E3819	Cylinder stud (1 1/8 in. O.A.)	2	2	2	2
28	E1534A	Dowel	2	2	2	2
29	E3835	Left main bearing (Ball-journal)	1	1	1	1
30	E3876	Oil seal	1	1	1	1
31	E3724	Filter spring	1	1	1	1
32	E3722	Filter	1	1	1	1
33	E3723	Sealing washer	1	1	1	1
34	E1564	Filter cap	1	1	1	1
35	E1577	Joint washer	1	1	1	1
36	E3078	Breather extension rubber pipe	1	1	1	1
37	T1399	Stud (3 1/8 in. O.A.)	2	2	2	2
38	T1112	Drain plug (with level tube)	1	1	1	1
39	WE 170	Fibre washer	1	1	1	1
40	T361	Level plug	1	1	1	1
41	T1257	Fibre washer	3	3	3	3
42	E732	Filler plug	2	2	2	2
43	NE507	Fibre washer	2	2	2	2
44	E4587	Distributor hole plug	1	1	1	1
45	E4593	Fibre washer	1	1	1	1
46	E4706	Tachometer drive plug	2	2	2	2

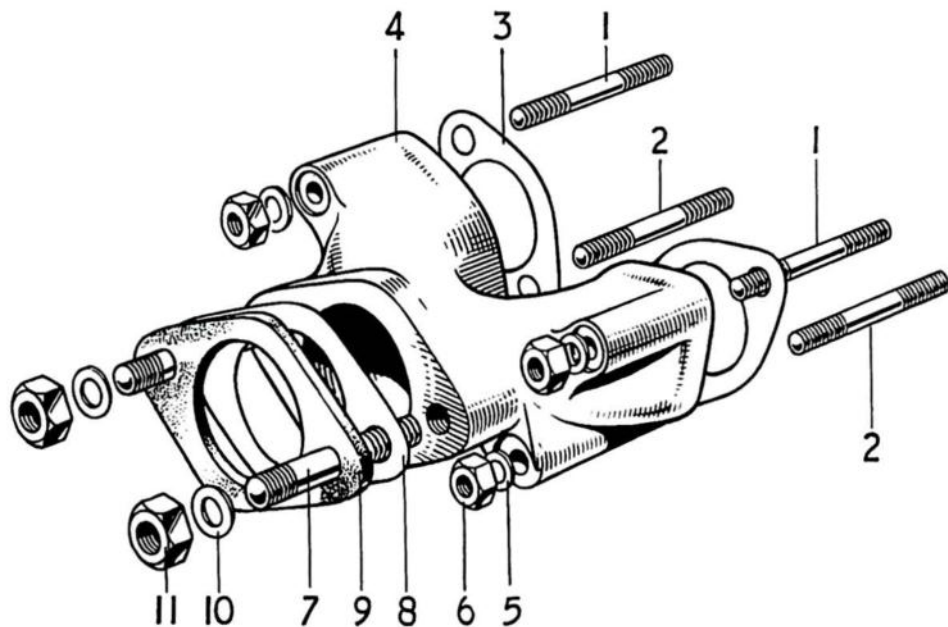
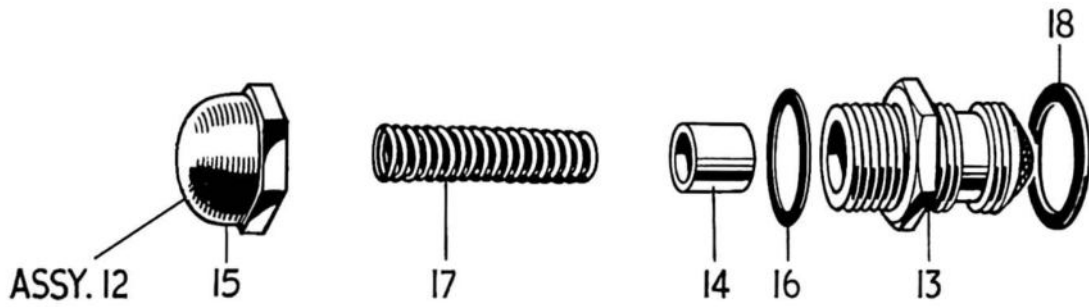
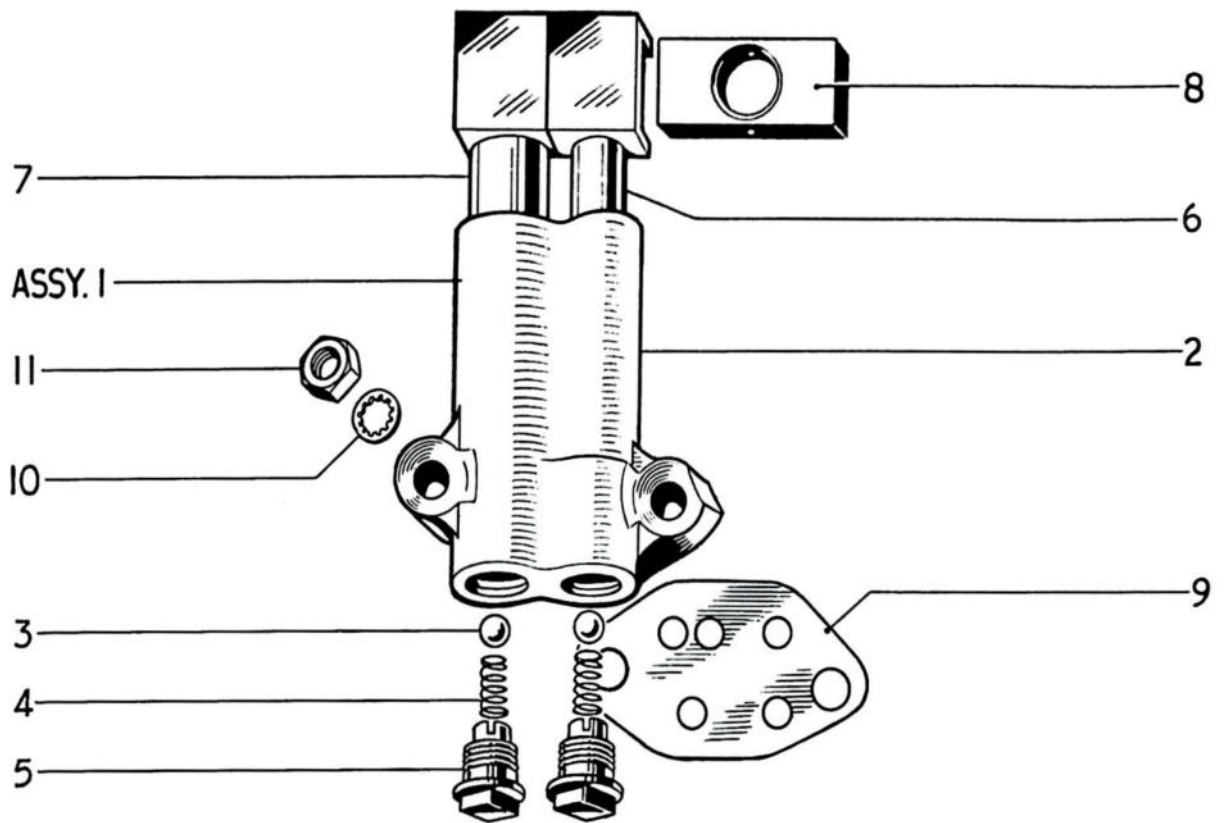

Fig. 3. OIL PUMP, RELEASE VALVE AND INLET MANIFOLD

Ref. No. Part No. DESCRIPTION QUANTITY

OIL PUMP AND RELEASE VALVE

								3TA	5TA	T90	T100SS
1	E3878	OIL PUMP	1	1	1	1
2	E3731	Pump body...	1	1	1	1
3	S70-7	Valve ball	2	2	2	2
4	E403	Valve spring	2	2	2	2
5	E2360	Screwed plug	2	2	2	2
6	GS153	Feed plunger	1	1	1	1
7	E1476	Scavenge plunger	1	1	1	1
8	E495	Drive block	1	1	1	1
9	E3730	Joint washer	1	1	1	1
10	E3887	Serrated washer	2	2	2	2
11	E3732	Nut	2	2	2	2
12	E5896	OIL RELEASE VALVE	1	1	1	1
13	E2794	Valve body	1	1	1	1
14	GS251	Piston	1	1	1	1
15	E2304	Cap	1	1	1	1
16	GS254	Fibre washer	1	1	1	1
17	E6062	Main spring	1	1	1	1
18	E1670	Fibre washer	1	1	1	1

INLET MANIFOLD

1	E3796	Stud (1 17/32 in. O.A.)	2	2	2	2
2	E3797	Stud (2 in. O.A.)	2	2	2	2
3	E2967	Joint washer	2	2	2	2
4	E3761	Inlet manifold	1	-	-	-
4	E4014	Inlet manifold	-	1	-	1
4	E4689	Inlet manifold	-	-	1	-
5	S25-13	Plain washer	4	4	4	4
6	W103	Nut	4	4	4	4
7	E3880	Stud (1 1/4 in. O.A.)	2	2	2	2
8	NA 43	Joint washer	1	1	-	-
8	NA 43A	Joint washer	-	-	1	1
9	E3834	Insulating block	1	1	-	-
9	E4504	Insulating block	-	-	1	-
9	E2968	Insulating block	-	-	-	1
10	S25-3	Plain washer	2	2	2	2
11	S1-51	Nut	2	2	2	2

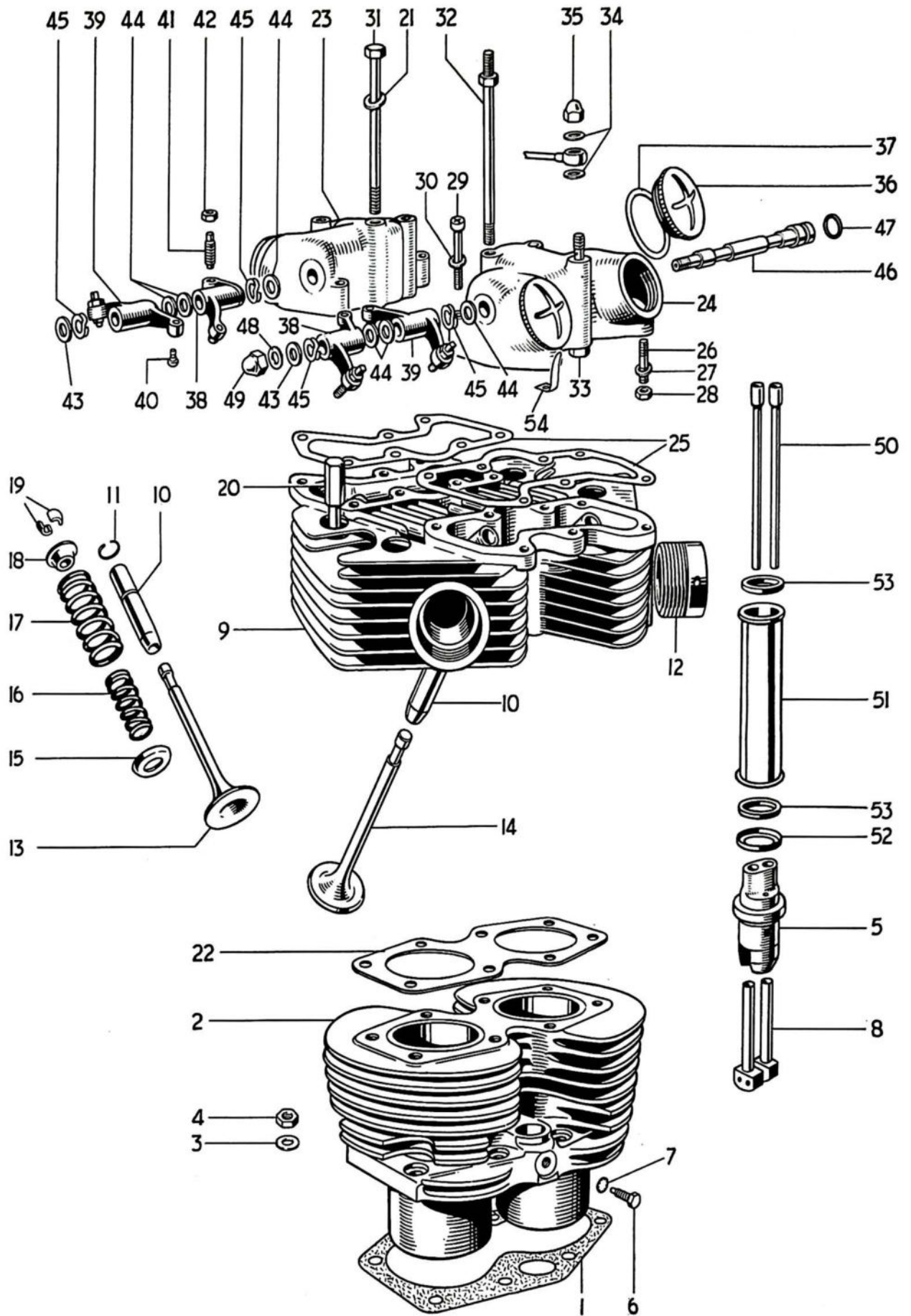

Fig. 4. CYLINDER BLOCK AND HEAD, 3TA AND T90

Ref. No. Part No. DESCRIPTION QUANTITY

CYLINDER BLOCK AND HEAD, 3TA AND T90

										3TA	T90
1	E3798	Cylinder base washer	1	1
2	E3698	Cylinder block	1	1
3	GS308	Plain washer	8	8
4	E2412	Nut	8	8
5	E4676	Tappet guide block	2	2
6	H200	Tappet block screw ($\frac{7}{8}$ in. U.H.)	2	2
7	E1612	Serrated washer	2	2
8	E3753	Tappet	4	4
9	E5956	CYLINDER HEAD c/w GUIDES	1	-
9	E4784	CYLINDER HEAD c/w GUIDES	-	1
10	E3208	Valve guide	4	4
11	E3209	Valve guide circlip	4	4
12	E2961	Exhaust pipe adaptor	2	2
13	E3738	Inlet valve	2	-
13	E4640	Inlet valve	-	2
14	E3739	Exhaust valve	2	2
15	E3740	Bottom cup	4	4
16	E3942	Inner valve spring	4	-
17	E3741	Outer valve spring	4	-
16	E4010	Inner valve spring	-	4
17	E4011	Outer valve spring	-	4
18	E3742	Top collar	4	4
19	WE259A	Split cotter	8	8
20	E4456	Cylinder head bolt (2 25/32 in. U.H.)	4	4
21	F2184	Plain washer	8	8
22	E4674	Cylinder head gasket	1	1
23	E3745	Inlet rocker box	1	1
24	E3744	Exhaust rocker box	1	1
25	E3743	Joint washer	2	2
26	E3858	Rocker box stud ($\frac{1}{8}$ in. O.A.)	4	4
27	E3302	Plain washer	4	4
28	F879	Nut	4	4
29	E3668	Screw ($\frac{1}{2}$ in. U.H.)	4	4
30	E3857	Plain washer	4	4
31	E3794	Cylinder head bolt (5 $\frac{7}{8}$ in. U.H.)	2	2
32	E3795	Cylinder head torque stay bolt	2	2
33	E3809	Oil feed bolt	2	2
34	F1880	Copper washer	6	6
35	H400	Domed nut	2	2
36	E4610	Inspection cap	4	4
37	E3751	Fibre washer	4	4
38	E3749	ROCKER (Right exhaust, left inlet)	2	2
39	E3750	ROCKER (Left exhaust, right inlet)	2	2
40	E3222	Rocker ball pin	4	4
41	E3223	Rocker adjusting pin	4	4
42	GS662	Adjuster lock nut	4	4
43	E1330	Thrust washer, $\frac{3}{8}$ in.	2	2
44	E2534	Thrust washer, $\frac{7}{8}$ in.	6	6
45	E3224	Spring washer	4	4
46	E3748	Rocker spindle	2	2
47	E3253	Sealing rubber	2	2
48	E1335	Copper washer	2	2

(Continued)

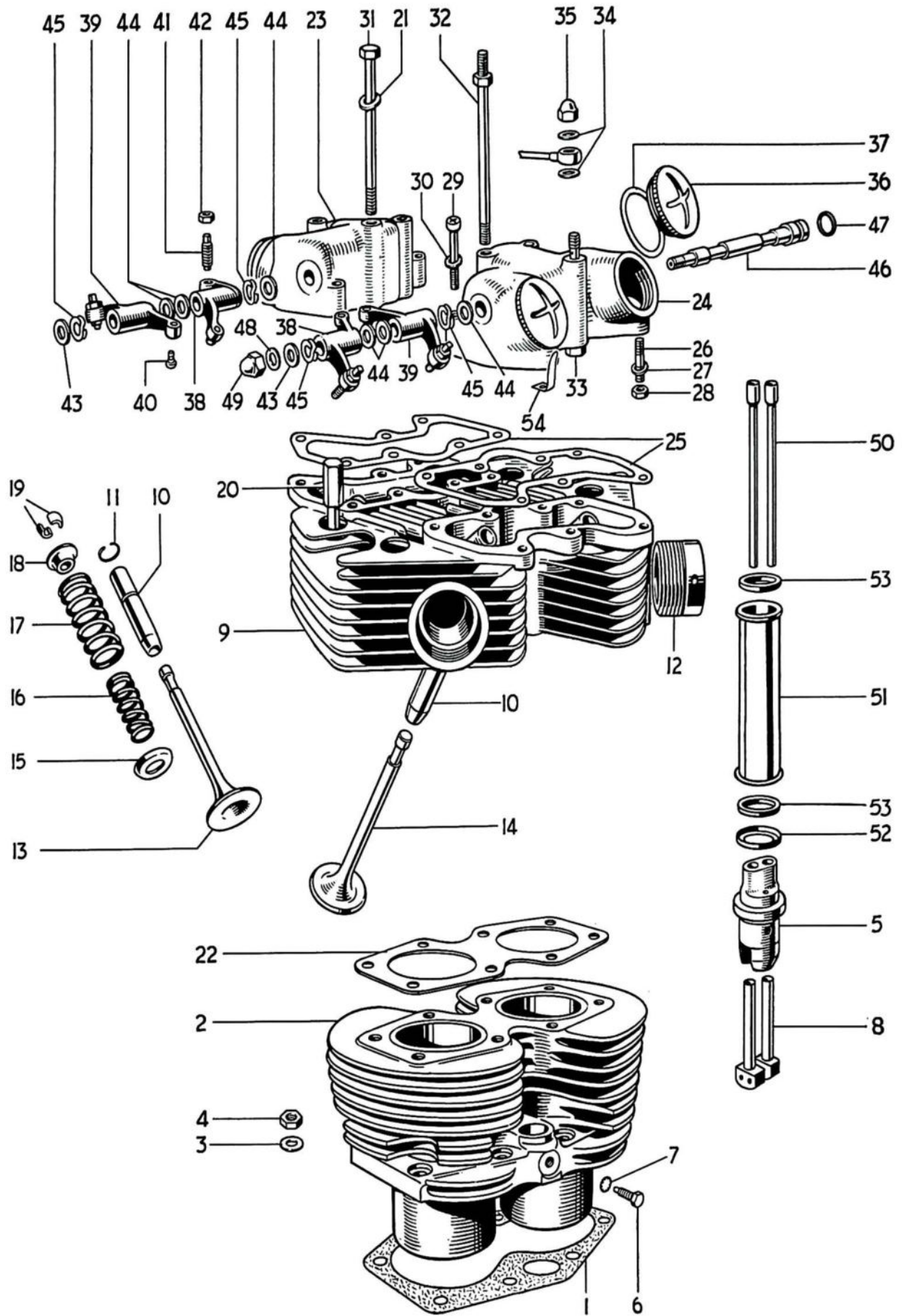

Fig. 4. CYLINDER BLOCK AND HEAD, 3TA AND T90

Ref. No.	Part No.	DESCRIPTION	QUANTITY
----------	----------	-------------	----------

CYLINDER BLOCK AND HEAD, 3TA AND T90
(Continued)

											3TA	T90
49	E1435	Domed nut	2	2
50	E3759	Push rod	4	4
51	E4751	Cover tube	2	2
52	E4746	Bottom cup	2	2
53	E4752	Rubber washer	4	4
54	E4671	Locking spring	4	4

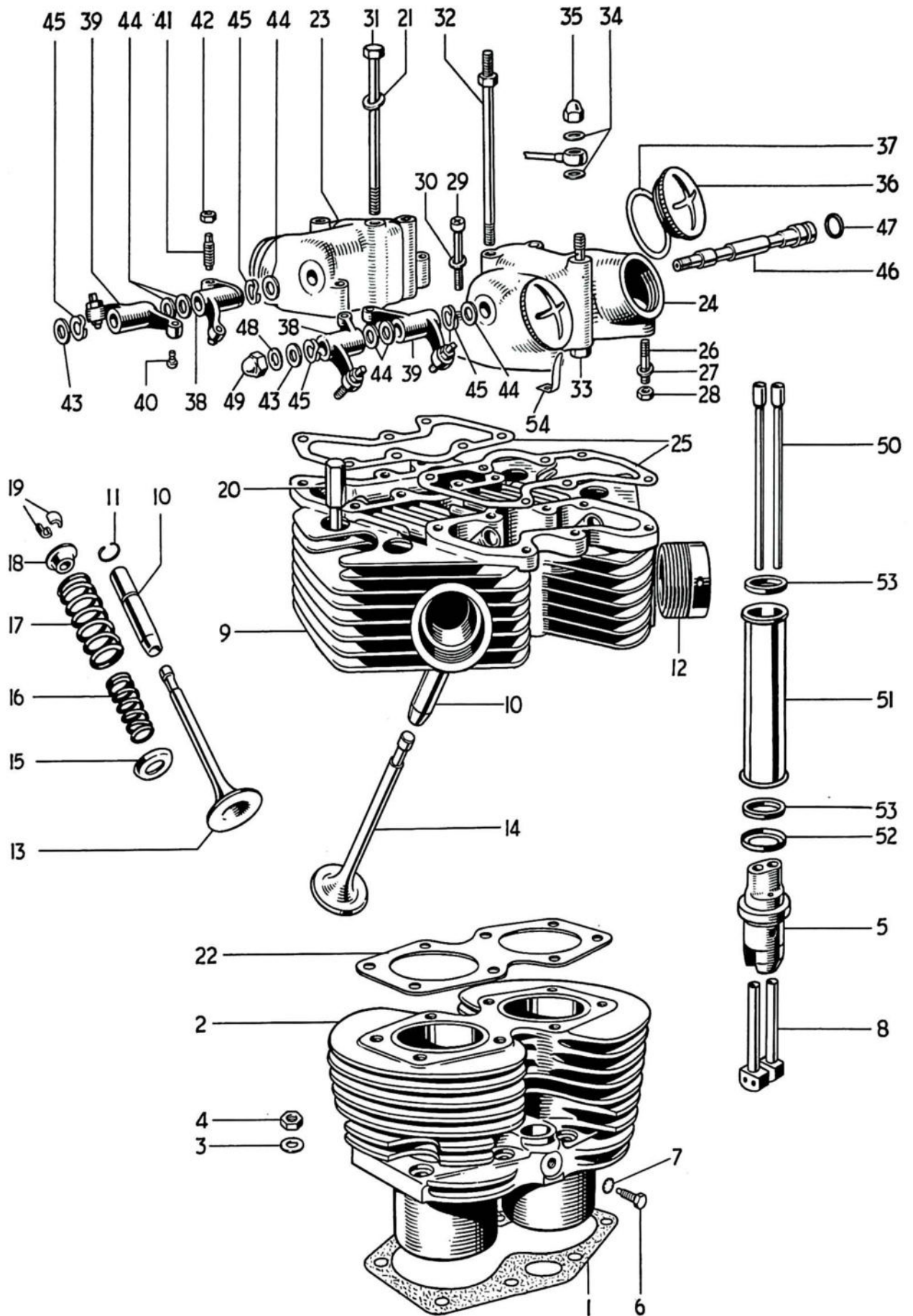

Fig. 5. CYLINDER BLOCK AND HEAD, 5TA AND T100SS

Ref. No.	Part No.	DESCRIPTION	5TA	T100SS
CYLINDER BLOCK AND HEAD, 5TA AND T100SS				
1	E3798	Cylinder base washer	1	1
2	E4000	Cylinder block	1	1
3	GS308	Plain washer	8	8
4	E2412	Nut	8	8
5	E4676	Tappet guide block	2	2
6	H200	Tappet block screw ($\frac{7}{8}$ in. U.H.)	2	2
7	E1612	Serrated washer	2	2
8	E3753	Tappet	4	4
9	E4785	CYLINDER HEAD c/w GUIDES	1	1
10	E3208	Valve guide	4	4
11	E3209	Valve guide circlip	4	4
12	E2961	Exhaust pipe adaptor	2	2
13	E4012	Inlet valve	2	2
14	E4013	Exhaust valve	2	2
15	E3740	Bottom cap	4	4
16	E4010	Inner valve spring	4	4
17	E4011	Outer valve spring	4	4
18	E3742	Top collar	4	4
19	WE259A	Split cotter	8	8
20	E4456	Cylinder head bolt (2 25/32 in. U.H.)	4	4
21	F2184	Plain washer	8	8
22	E4675	Cylinder head gasket	1	1
23	E3745	Inlet rocker box	1	1
24	E3744	Exhaust rocker box	1	1
25	E3743	Joint washer	2	2
26	E3858	Rocker box stud ($\frac{1}{8}$ in. O.A.)	4	4
27	E3302	Plain washer	4	4
28	F879	Nut	4	4
29	E3668	Screw ($\frac{1}{8}$ in. U.H.)	4	4
30	E3857	Plain washer	4	4
31	E3794	Cylinder head bolt (5 $\frac{7}{8}$ in. U.H.)	2	2
32	E3795	Cylinder head torque stay bolt	2	2
33	E3809	Oil feed bolt	2	2
34	F1880	Copper washer	6	6
35	E400	Domed nut	2	2
36	E4610	Inspection cap	4	4
37	E3751	Fibre washer	4	4
38	E3749	ROCKER (right exhaust, left inlet)	2	2
39	E3750	ROCKER (left exhaust, right inlet)	2	2
40	E3222	Rocker ball pin	4	4
41	E3223	Rocker adjusting pin	4	4
42	GS662	Adjuster lock nut	4	4
43	E1330	Thrust washer, $\frac{3}{8}$ in.	2	2
44	E2534	Thrust washer, $\frac{1}{8}$ in.	6	6
45	E3224	Spring washer	4	4
46	E3748	Rocker spindle	2	2
47	E3253	Sealing rubber	2	2
48	E1335	Copper washer	2	2
49	E1435	Domed nut	2	2
50	E4008	Push rod	4	4
51	E4751	Cover tube	2	2
52	E4746	Bottom cup	2	2
53	E4752	Rubber washer	4	4
54	E4671	Locking spring	4	4

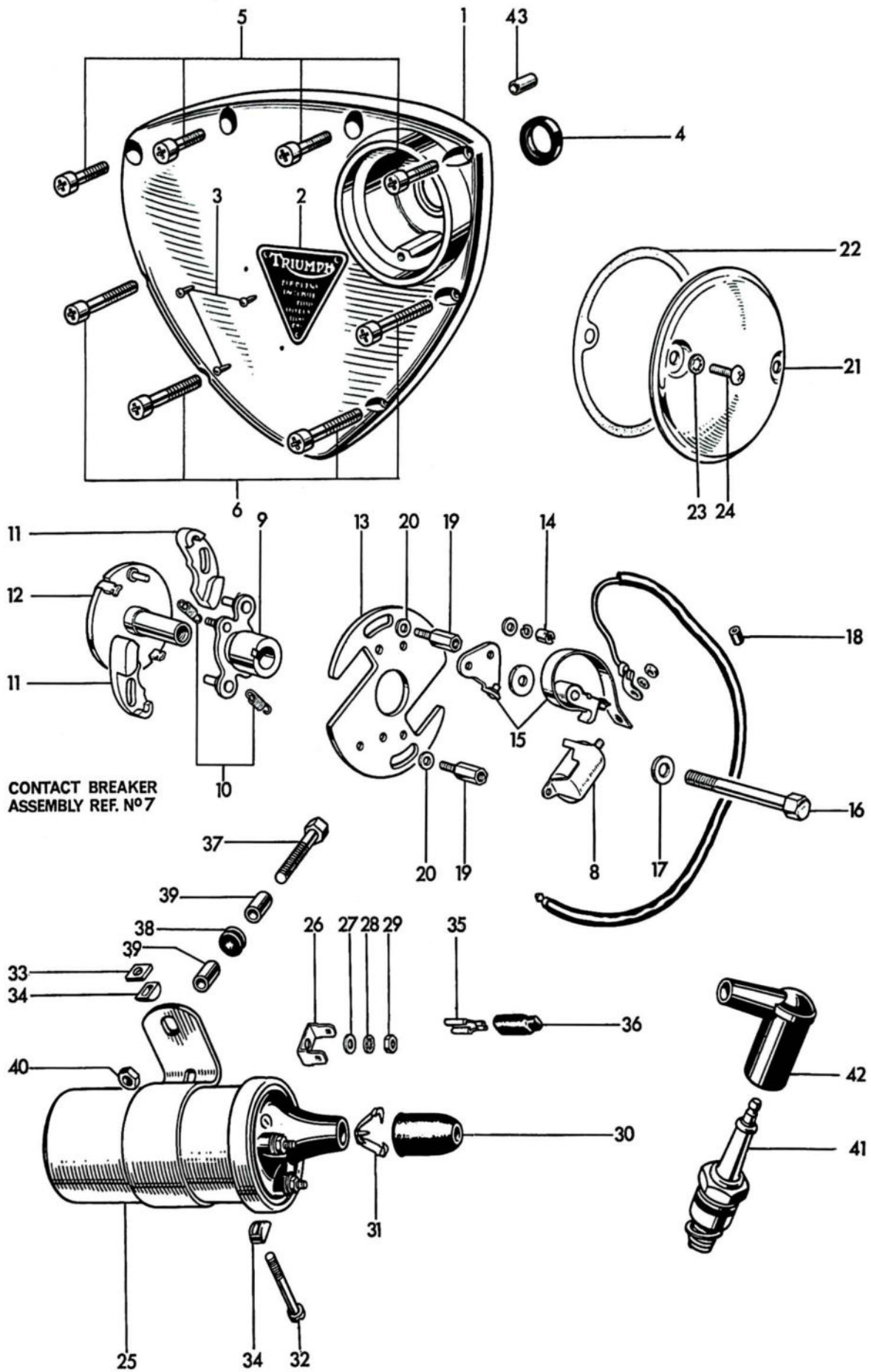

Fig. 6. TIMING COVER, CONTACT BREAKER AND COILS

Ref. No.	Part No.	DESCRIPTION	3TA	5TA	T90	T100SS
TIMING COVER, CONTACT BREAKER AND COILS						
1	E4630	Timing cover	1	1	1	1
2	E4016	Patent plate	1	1	1	1
3	D208-5	Hammer-drive screw	3	3	3	3
4	E4568	Oil seal	1	1	1	1
5	E3800	Screw ($\frac{7}{8}$ in. U.H.)	4	4	4	4
6	E3801	Screw ($1\frac{1}{8}$ in. U.H.)	4	4	4	4
7	47605	CONTACT BREAKER, type 4CA	1	1	1	1
8	425377	Condenser	2	2	2	2
9	54441729	Cam... ..	1	1	1	1
10	54415642	Spring set	1	1	1	1
11	425379	Weight	2	2	2	2
12	54415751	Sleeve and action plate	1	1	1	1
13	425370	Base plate	1	1	1	1
14	169194	Slotted nut... ..	4	4	4	4
15	54415803	Contact set	2	2	2	2
16	E5451	Bolt (2 in. U.H.)	1	1	1	1
17	S25-43	Plain washer	1	1	1	1
18	E4707	Grommet	1	1	1	1
19	E4747	Pillar bolt	2	2	2	2
20	E2351	Plain washer	2	2	2	2
21	E4571	Cover	1	1	1	1
22	E5049	Joint washer	1	1	1	1
23	GS299	Serrated washer	2	2	2	2
24	F4715	Screw (15/32 in. U.H.)	2	2	2	2
25	45152	IGNITION COIL, type MA6	2	2	2	2
26	54190108	Lucar terminal	4	4	4	4
27	131023	Plain washer (E2351)	4	4	4	4
28	188330	Serrated washer (GS299)... ..	4	4	4	4
29	166043	Nut (F3799)	4	4	4	4
30	421554	Rubber grommet	2	2	2	2
31	421863	Cable clip	2	2	2	2
32	100104	Screw	2	2	2	2
33	169160	Square nut	2	2	2	2
34	422369	"D" washer	4	4	4	4
35	54942078	Lucar connector	4	4	4	4
36	54190042	Insulating cover... ..	4	4	4	4
37	F3809	Bolt ($1\frac{3}{4}$ in. U.H.)	2	2	2	2
38	F5466	Rubber grommet	2	2	2	2
39	F5467	Distance piece	4	4	4	4
40	E3290	Self-locking nut	2	2	2	2
41	—	Sparking plug (Champion N4)	2	2	2	2
42	D297	Plug cover and suppressor	2	2	2	2
42	D262	Plug cover	A	A	A	A
43	T989	Hollow dowel	1	1	1	1

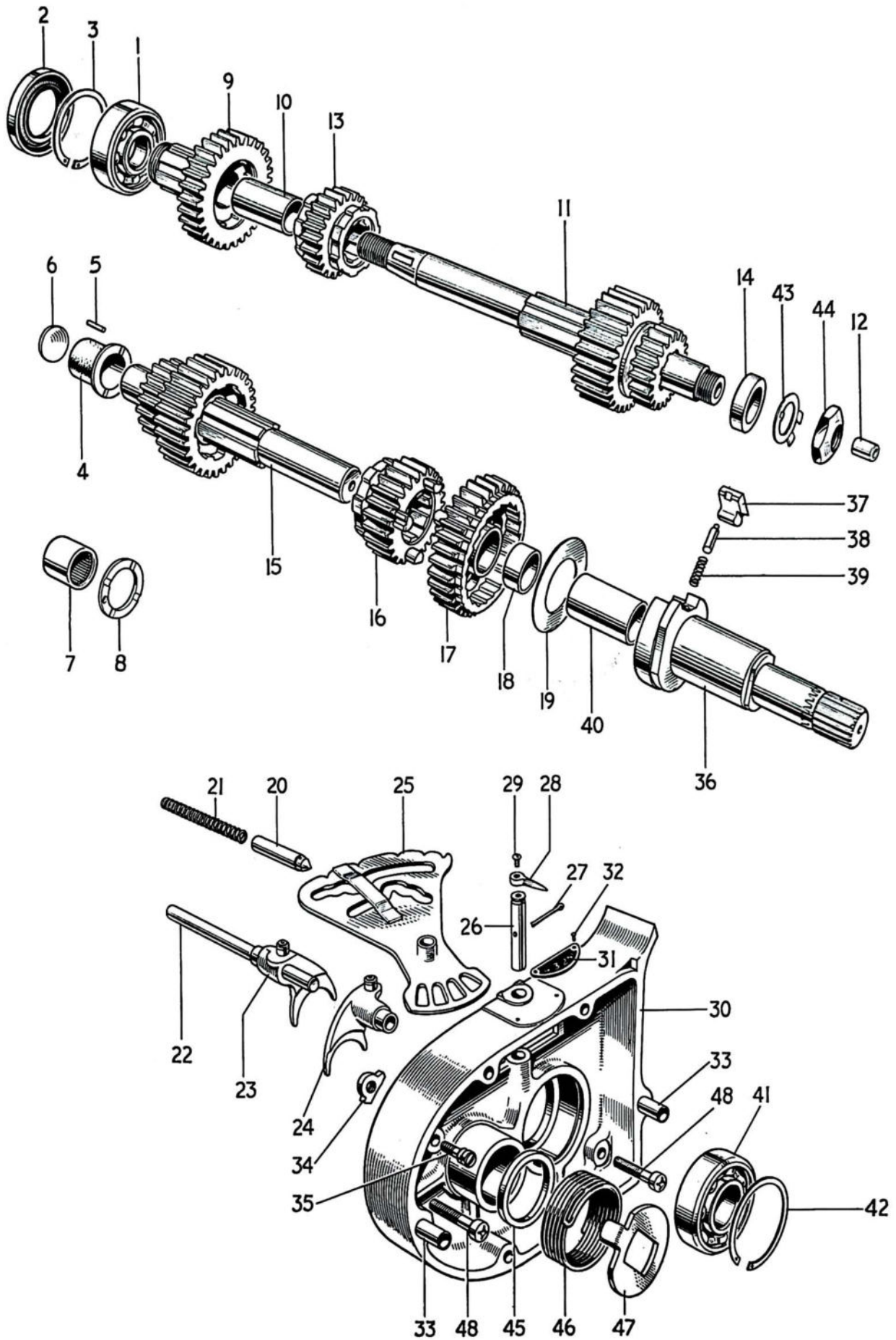

Fig. 7. GEARBOX SHAFTS, BEARINGS AND INNER COVER

Ref. No.	Part No.	DESCRIPTION	3TA	5TA	T90	T100SS
GEARBOX SHAFTS, BEARINGS AND INNER COVER						
1	T665	High gear bearing (ball journal)	1	1	1	1
2	T1478	Oil seal	1	1	1	1
3	W680	Circlip	1	1	1	1
4	T1367	Layshaft bush	1	1	-	-
5	T912	Peg	1	1	-	-
6	T981	Blanking disc	1	1	-	-
7	T1606	Layshaft bearing	-	-	1	1
8	T1607	Thrust washer	-	-	1	1
9	T1947	MAINSHAFT HIGH GEAR (22T)	1	1	1	1
10	T1405	High gear bush	1	1	1	1
11	T1948	MAINSHAFT c/w THIRD AND LOW GEARS (16/24T)	1	1	1	1
12	T1391	Clutch rod bush	1	1	1	1
13	T1922	Mainshaft second gear (21T)	1	1	1	1
14	T1411	Mainshaft distance piece	1	1	1	1
15	T1965	Layshaft c/w second and high gears (15/23T)	1	1	-	-
15	T1949	Layshaft c/w second and high gears (25/23T)	-	-	1	1
16	T1839	Layshaft third gear (20T)	1	1	1	1
17	T1950	LAYSHAFT LOW GEAR (27T)	1	1	1	1
18	T1393	Low gear bush	1	1	1	1
19	T1426	Pawl retaining disc	1	1	1	1
20	T1471	Camplate index plunger	1	1	1	1
21	T373	Index plunger spring	1	1	1	1
22	T1457	Selector fork spindle	1	1	1	1
23	T1480	Mainshaft selector fork	1	1	1	1
24	T1481	Layshaft selector fork	1	1	1	1
25	T1768	Gear selector camplate	1	1	1	1
26	T1418	Camplate spindle	1	1	1	1
27	$\frac{1}{8}$ in. x $\frac{3}{4}$ in.	Split pin	1	1	1	1
28	T1416	Gear indicator pointer	1	1	1	1
29	H688	Screw ($\frac{5}{16}$ in. U.H.)	1	1	1	1
30	T1448	Inner cover	1	1	1	1
31	T417	Gear indicator plate	1	1	1	1
32	D208-5	Indicator plate rivet	2	2	2	2
33	T1440	Hollow dowel	2	2	2	2
34	T1157	Kickstarter stop plate	1	1	1	1
35	T1390	Stop plate and anchor screw	1	1	1	1
36	T1445	KICKSTARTER SPINDLE	1	1	-	-
36	T1981	KICKSTARTER SPINDLE	-	-	1	1
37	T1431	Kickstarter pawl	1	1	1	1
38	T1282	Plunger	1	1	1	1
39	T1161	Plunger spring	1	1	1	1
40	T1897	Bearing	-	-	1	1
40	T1446	Floating bush	1	1	-	-
41	T1469	Mainshaft bearing (Ball journal)	1	1	1	1
42	T280	Circlip	1	1	1	1
43	T732	Tab washer	1	1	1	1
44	T2009	Mainshaft nut	1	1	1	1
45	T1464	Distance piece	1	1	1	1
46	T1441	Kickstarter return spring	1	1	1	1
47	T1422	Return spring plate	1	1	1	1
48	E3204	Screw (1 in. U.H.)	2	2	2	2

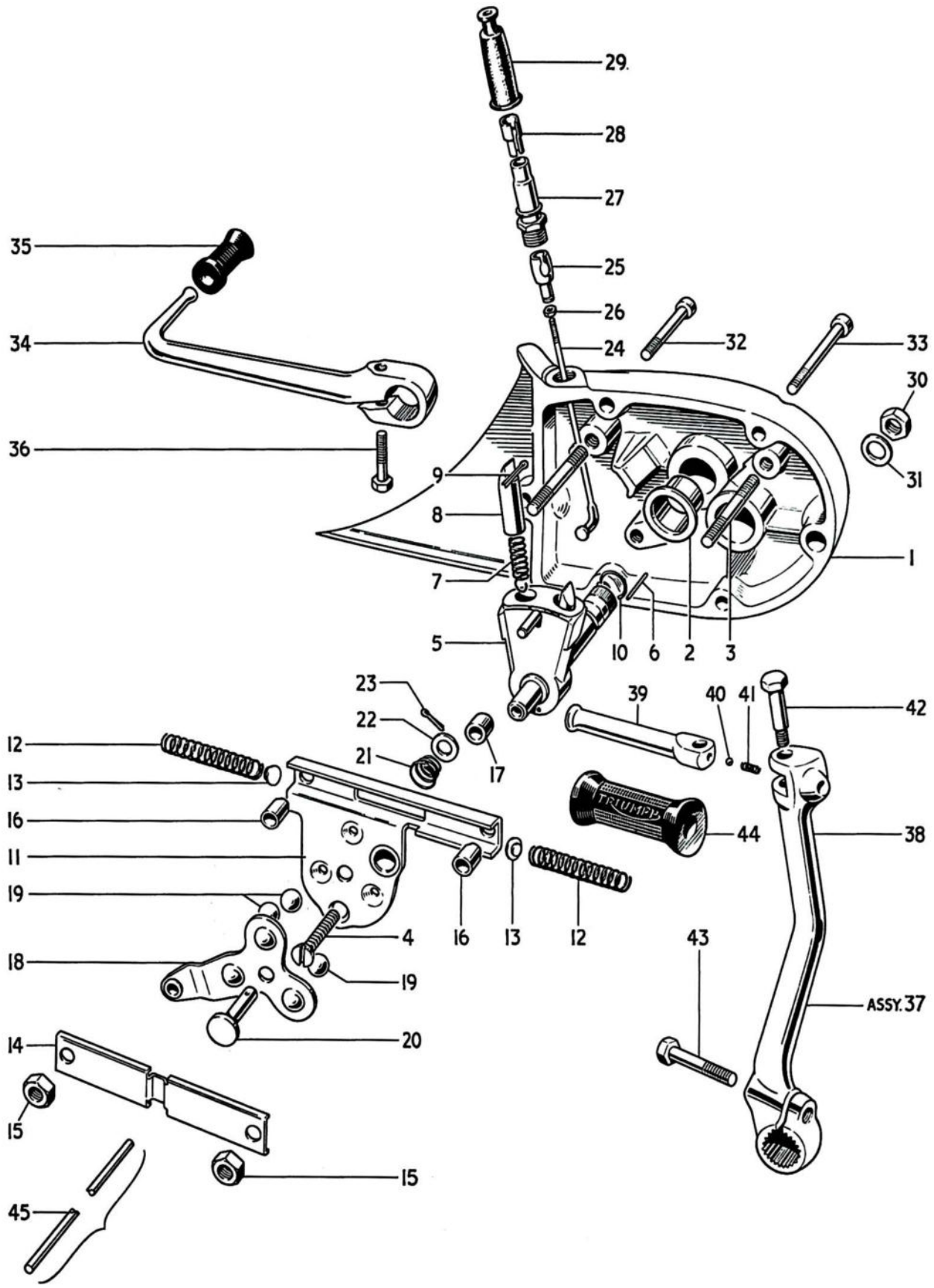

Fig. 8. GEARBOX OUTER COVER AND LEVERS

Ref. No. Part No.

DESCRIPTION

GEARBOX OUTER COVER AND LEVERS

								3TA	5TA	T90	T100SS
1	T1870	GEARBOX OUTER COVER	1	1	1	1
2	T1395	Gearchange spindle bush...	1	1	1	1
3	T1944	Stud (1 $\frac{1}{8}$ in. O.A.)	2	2	2	2
4	T1875	Screw ($\frac{7}{8}$ in. O.A.)	1	1	1	1
5	T1942	GEARCHANGE QUADRANT	1	1	1	1
6	T1474	Spring retaining pin	2	2	2	2
7	T1436	Plunger spring	2	2	2	2
8	T1396	Selector plunger	2	2	2	2
9	5/64 in. x $\frac{5}{8}$ in.	Split pin	2	2	2	2
10	E3309	Sealing ring	1	1	1	1
11	T1871	Return spring housing	1	1	1	1
12	T1877	Return spring	2	2	2	2
13	T1878	Thrust button	2	2	2	2
14	T1977	Cover	1	1	1	1
15	W103	Nut	3	3	3	3
16	T1876	Distance piece	2	2	2	2
17	T1874	Distance piece	1	1	1	1
18	T1880	Clutch lever	1	1	1	1
19	T1771	Ball, $\frac{3}{8}$ in. diam.	3	3	3	3
20	T1710	Shaft	1	1	1	1
21	T1712	Spring	1	1	1	1
22	GS127	Plain washer	1	1	1	1
23	5/64 in. x $\frac{1}{2}$ in.	Split pin	1	1	1	1
24	T1945	Spoke	1	1	1	1
25	T1946	Connector	1	1	1	1
26	T1937	Nut	1	1	1	1
27	T1644	Abutment	1	1	1	1
28	T1645	Adaptor	1	1	1	1
29	T1646	Rubber cover	1	1	1	1
30	S1-51	Nut	2	2	2	2
31	S25-3	Plain washer	2	2	2	2
32	T1401	Screw (2 $\frac{3}{8}$ in. U.H.)	2	2	2	2
33	T1402	Screw (2 $\frac{5}{8}$ in. U.H.)	2	2	2	2
34	T1435	Gearchange lever	1	1	1	1
35	T449	Pedal rubber	1	1	1	1
36	W932	Bolt (1 in. U.H.)	1	1	1	1
37	T1677	KICKSTARTER LEVER COMPLETE...	1	1	1	1
38	T1678	Kickstarter crank	1	1	1	1
39	T1272	Kickstarter pedal	1	1	1	1
40	S70-3	Steel ball ($\frac{1}{4}$ in. diam.)	1	1	1	1
41	T1167	Index spring	1	1	1	1
42	T1273	Pivot bolt	1	1	1	1
43	T1439	Clamp bolt (1 $\frac{1}{8}$ in. U.H.)	1	1	1	1
44	F1814	Pedal rubber	1	1	1	1
45	T1456	Clutch operating rod	1	-	-	-
45	T1970	Clutch operating rod	-	1	1	1

CLUTCH ASSEMBLY N° 1

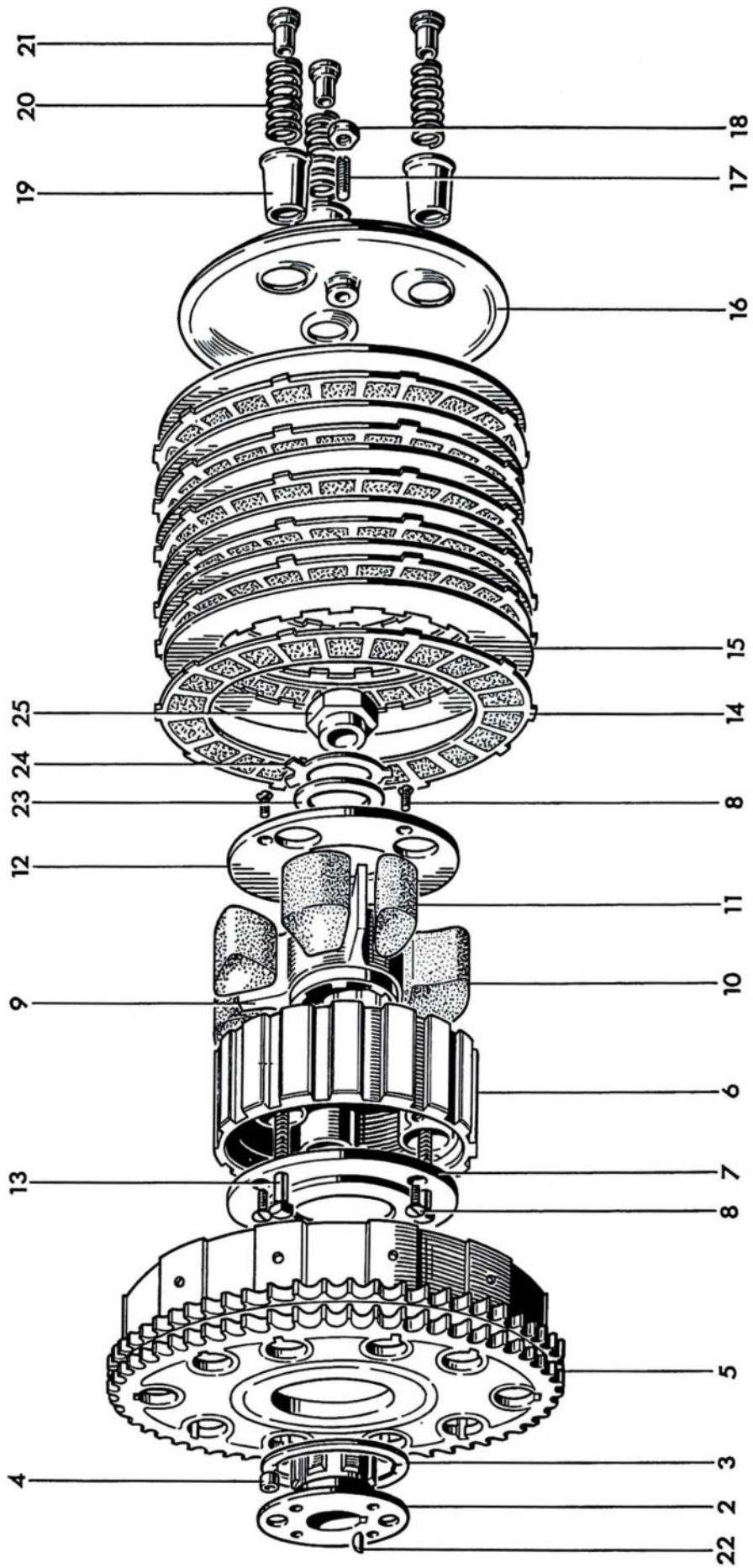

Fig. 9. CLUTCH

Ref. No.	Part No.	DESCRIPTION	3TA	5TA	T90	T100SS
CLUTCH						
1	T1933	CLUTCH COMPLETE	1	-	-	-
1	T1935	CLUTCH COMPLETE	-	1	1	1
2	T1751	Hub	1	1	1	1
3	T1735	Thrust washer	1	1	1	1
4	T394	Roller	20	20	20	20
5	T1442	Sprocket and housing	1	-	-	-
5	T1570	Sprocket and housing	-	1	1	1
6	T1718	Centre (Shock absorber body)	1	-	-	-
6	T1719	Centre (Shock absorber body)	-	1	1	1
7	T1720	Inner plate	1	1	1	1
8	T1040	Countersunk screw (0.417 in. U.H.)	6	6	6	6
9	T1721	Shock absorber spider	1	1	1	1
10	T1722	Drive rubber (large)	3	3	3	3
11	T1723	Rebound rubber (small)	3	3	3	3
12	T1724	Outer plate	1	1	1	1
13	T423	Screwed pin (1 19/32 in. U.H.)	3	-	-	-
13	T423A	Screwed pin (1 27/32 in. U.H.)	-	3	3	3
14	T1362	Driving plate (bonded)	5	6	6	6
15	T1363	Driven plate (plain)	5	6	6	6
16	T1929	Pressure plate	1	1	1	1
17	T1256	Adjuster pin	1	1	1	1
18	GS662	Nut	1	1	1	1
19	T1934	Spring cup	3	-	-	-
19	T1931	Spring cup	-	3	3	3
20	T1752	Spring	3	-	-	-
20	T1560	Spring	-	3	3	3
21	T427	Brass nut	3	3	3	3
22	S66-1	Key	1	1	1	1
23	T1045	Cupped washer	1	1	1	1
24	T1046	Tab washer	1	1	1	1
25	T1047	Nut	1	1	1	1

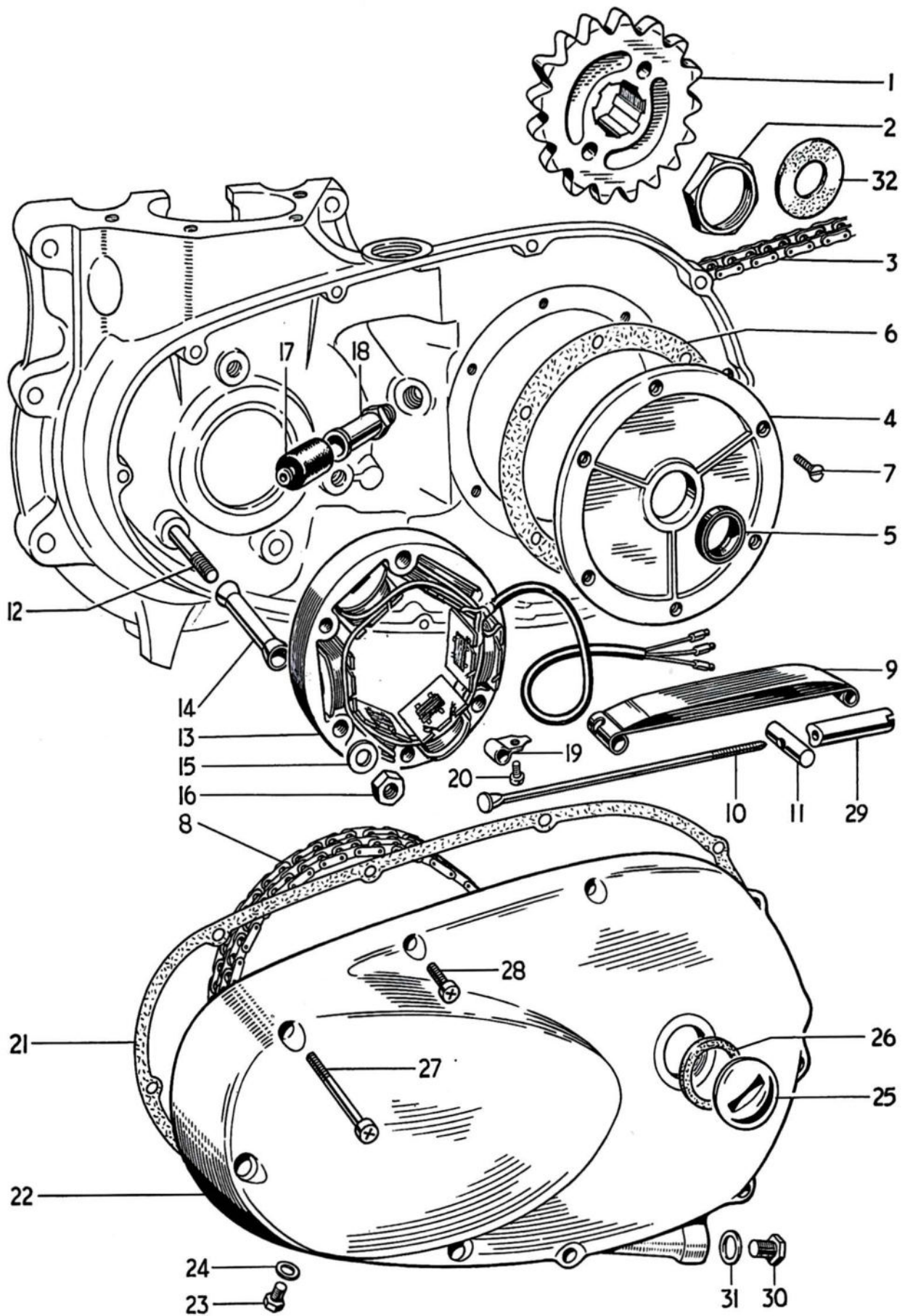

Fig. 10. CHAINCASE AND CHAINS

CHAINCASE AND CHAINS

								3TA	5TA	T90	T100SS
1	T1476	Gearbox sprocket (18 teeth)	1	-	-	1
1	T1558	Gearbox sprocket (17 teeth)	-	-	1	-
1	T1569	Gearbox sprocket (20 teeth)	-	1	-	-
1	T1476/19	Gearbox sprocket (19 teeth)	A	A	A	A
2	T1434	Gearbox sprocket nut	1	1	1	1
3	D530	Rear chain, $\frac{5}{8}$ in. x $\frac{3}{8}$ in. x 104L	-	1	-	-
3	D444	Rear chain, $\frac{5}{8}$ in. x $\frac{3}{8}$ in. x 102L	1	-	1	1
4	E3789	Cover plate	1	1	1	1
5	E3833	Oil seal	1	1	1	1
6	E3832	Joint washer	1	1	1	1
7	E3821	Countersunk screw ($\frac{7}{16}$ in. U.H.)	6	6	6	6
8	D358	Primary chain, $\frac{3}{8}$ in. Duplex 78L	1	1	1	1
9	E4149	Chain tensioner blade	1	1	1	1
10	E4152	Tie rod	1	1	1	1
11	E4148	Trunnion	1	1	1	1
12	E3811	Stud (3 $\frac{7}{16}$ in. O.A.)	3	3	3	3
13	47162	Stator, RM 19	1	1	1	1
14	E3810	Distance piece	3	3	3	3
15	S25-3	Plain washer	3	3	3	3
16	E5324	Nut	3	3	3	3
17	E4144	Rubber grommet	1	1	1	1
18	E5872	Sleeve nut	1	1	1	1
19	E1509	Clip	1	1	1	1
20	T361	Bolt ($\frac{1}{4}$ in. U.H.)	1	1	1	1
21	E4156	Joint washer	1	1	1	1
22	E4122	Chaincase	1	1	1	1
23	DS57	Drain and level plug	1	1	1	1
24	WE170	Fibre washer	2	1	1	1
25	E732	Filler plug	1	1	1	1
26	NE507	Fibre washer	1	1	1	1
27	E3802	Screw (2 $\frac{3}{4}$ in. U.H.)	3	3	3	3
28	E3668	Screw (1 $\frac{7}{8}$ in. U.H.)	7	7	7	7
29	E4153	Adjuster sleeve nut	1	1	1	1
30	E4154	Drain plug	1	1	1	1
31	T1738	Fibre washer	1	1	1	1
32	T1979	Felt washer	1	1	1	1

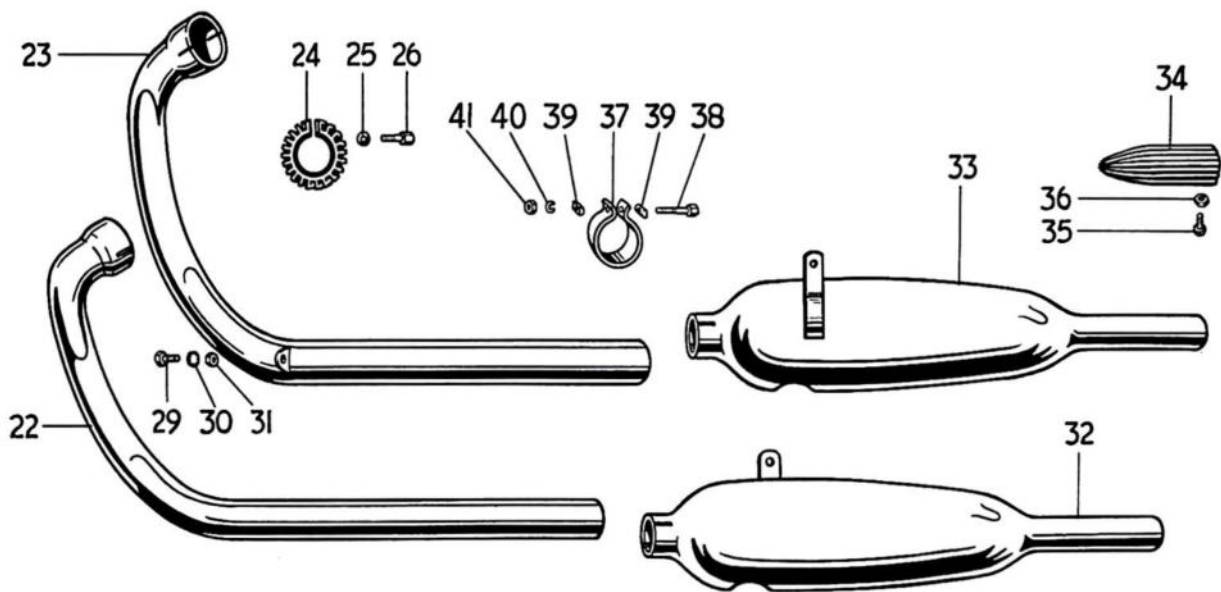
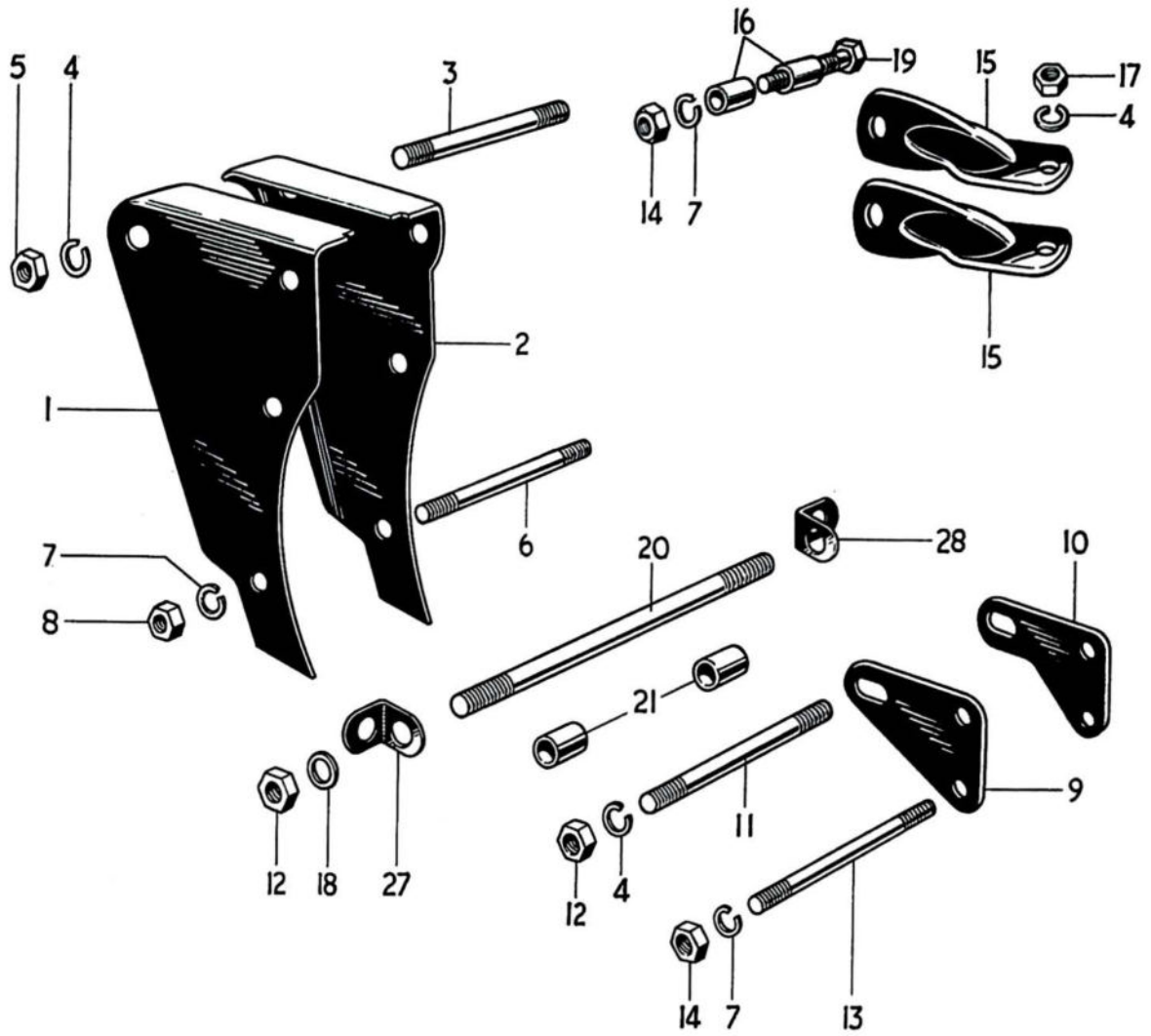

Fig. 11. ENGINE FITTINGS AND EXHAUST SYSTEM

Ref. No.	Part No.	DESCRIPTION	3TA	5TA	T90	T100SS
ENGINE FITTINGS AND EXHAUST SYSTEM						
1	F4275	Left front engine plate...	1	1	1	1
2	F4276	Right front engine plate	1	1	1	1
3	F2825	Stud (3¼ in. O.A.)	1	1	1	1
4	S26-1	Spring washer	8	8	8	8
5	PO172A	Nut ...	2	2	2	2
6	E3804	Stud (3 in. O.A.)	3	3	3	3
7	S26-3	Spring washer	8	8	8	8
8	S1-51	Nut ...	3	3	3	3
9	F4229	Left rear engine plate	1	1	1	1
10	F4230	Right rear engine plate	1	1	1	1
11	E3665	Stud (4¼ in. O.A.)	1	1	1	1
12	PO172A	Nut ...	4	4	4	4
13	E3695	Stud (4⅞ in. O.A.)	2	2	2	2
14	S1-51	Nut ...	5	5	5	5
15	E4778	Torque stay	2	2	2	2
16	E5072	Distance piece ...	2	2	2	2
17	S1-52	Nut ...	2	2	2	2
18	F5532	Plain washer ...	2	2	2	2
19	E4165	Bolt (1½ in. U.H.)	1	1	1	1
20	E3812	Stud (7⅞ in. O.A.)	1	1	1	1
21	F4197	Distance piece ...	2	2	2	2
22	E3992	Left exhaust pipe	-	1	-	1
23	E3994	Right exhaust pipe	-	1	-	1
22	E5325	Left exhaust pipe	1	-	1	-
23	E5327	Right exhaust pipe	1	-	1	-
24	E4947	Finned clip ...	2	2	2	2
25	E410A	Hemispherical washer ...	2	2	2	2
26	E409	Bolt (1⅞ in. U.H.)	2	2	2	2
27	F4707	Left bracket ...	1	1	1	1
28	F4283	Right bracket ...	1	1	1	1
29	DS57	Bolt (⅞ in. U.H.)	2	2	2	2
30	E1612	Serrated washer	2	2	2	2
31	F879	Nut ...	2	2	2	2
32	E3935	Left silencer ...	1	1	1	1
33	E3936	Right silencer ...	1	1	1	1
34	E4155	Silencer mute ...	A	A	A	A
35	H689	Screw (¼ in. U.H.)	A	A	A	A
36	H691	Nut ...	A	A	A	A
37	E2271	Clip ...	2	2	2	2
38	F3430	Bolt (1¾ in. U.H.)	2	2	2	2
39	E3768	"D" washer ...	4	4	4	4
40	S26-3	Spring washer ...	2	2	2	2
41	E1310	Nut ...	2	2	2	2

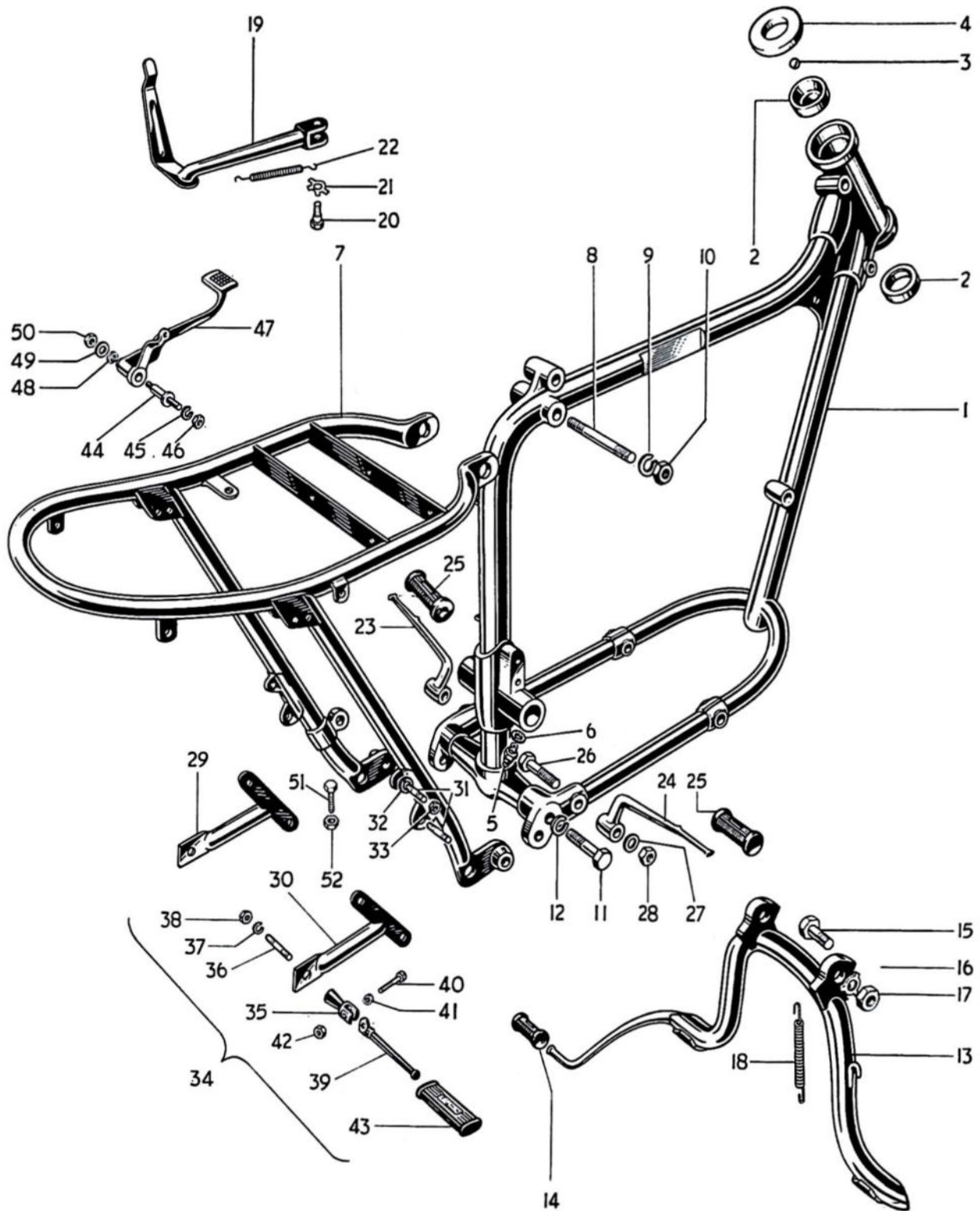

Fig. 12. FRAME

Ref. No.	Part No.	DESCRIPTION	3TA	5TA	T90	T100SS
FRAME						
1	F5406	Front frame	1	1	1	1
2	H1130	Steering race cup	2	2	2	2
3	S70-4	Steel ball ($\frac{7}{8}$ in. U.H.)	48	48	48	48
4	H1140	Top cone and dust cover	1	1	1	1
5	NW100	Grease nipple	1	1	1	1
6	WE170	Fibre washer	1	1	1	1
7	F6223	Rear frame	1	1	1	1
8	F4510	Stud ($4\frac{3}{8}$ in. O.A.)	1	1	1	1
9	S26-1	Spring washer	2	2	2	2
10	S1-52	Nut	2	2	2	2
11	F3780	Bolt ($1\frac{1}{8}$ in. U.H.)	2	2	2	2
12	PCW73A	Spring washer	2	2	2	2
13	F5529	Centre stand	1	1	-	-
13	F5153	Centre stand	-	-	1	1
14	T449	Pedal rubber	1	1	1	1
15	F3619	Pivot bolt ($1\frac{1}{8}$ in. U.H.)	2	2	2	2
16	F4484	Tab washer	2	2	2	2
17	F2725	Nut	2	2	2	2
18	F3617	Return spring	1	1	1	1
19	F4388	Prop stand	1	1	-	-
19	F3723	Prop stand	-	-	1	1
20	F3097	Pivot bolt	1	1	1	1
21	F3096	Tab washer	1	1	1	1
22	F2610	Return spring	1	1	1	1
23	F4214	Left footrest	1	1	1	1
24	F4215	Right footrest	1	1	1	1
25	NF704	Pedal rubber	2	2	2	2
26	F4369	Bolt ($2\frac{1}{8}$ in. U.H.)	2	2	2	2
27	F4370	Plain washer	2	2	2	2
28	DS47	Nut	2	2	2	2
29	F5087	Left pillion footrest support	1	1	1	1
30	F5088	Right pillion footrest support	1	1	1	1
31	E1396	Stud ($\frac{1}{2}$ in. O.A.)	4	4	4	4
32	S26-3	Spring washer	4	4	4	4
33	S1-51	Nut	4	4	4	4
34	F4327	PILLION FOOTREST	2	2	2	2
35	F2268	Footrest hanger	2	2	2	2
36	F4309	Stud ($1\frac{3}{8}$ in. O.A.)	2	2	2	2
37	S26-1	Spring washer	2	2	2	2
38	PO172A	Nut	2	2	2	2
39	F1694	Pedal	2	2	2	2
40	F2271	Pivot bolt	2	2	2	2
41	F2277	Spring washer	2	2	2	2
42	S1-51	Nut	2	2	2	2
43	F1695	Pedal rubber	2	2	2	2
44	F4284	Brake pedal spindle	1	1	1	1
45	SCZ45	Spring washer	1	1	1	1
46	DS48	Nut	1	1	1	1
47	F4314	Brake pedal	1	1	1	1
48	S26-16	Spring washer	1	1	1	1
49	S25-2	Plain washer	1	1	1	1
50	S1-52	Nut	1	1	1	1
51	F1149	Pedal stop screw ($\frac{1}{8}$ in. U.H.)	1	1	1	1
52	F879	Nut	1	1	1	1

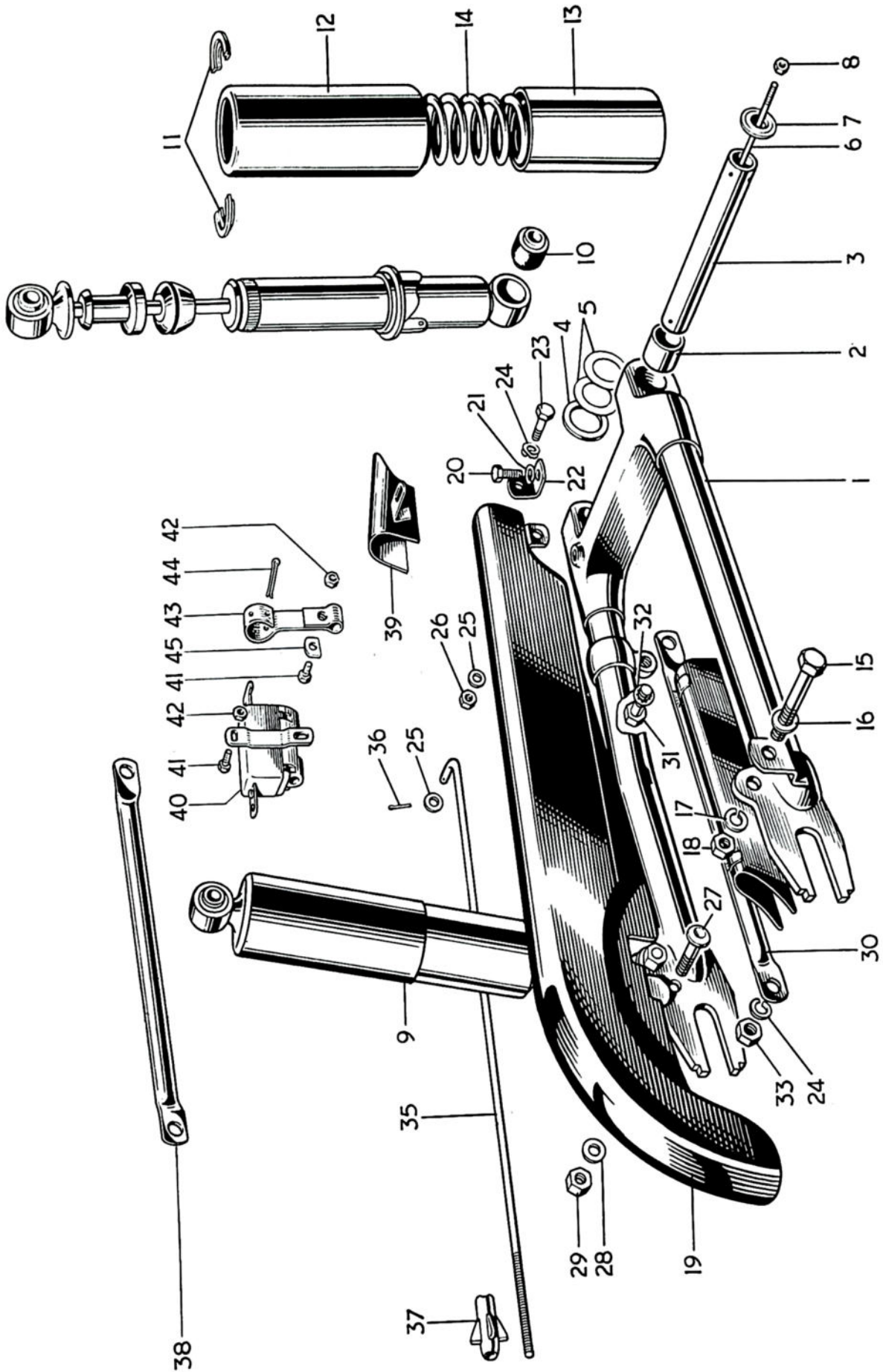

Fig. 13. SWINGING FORK, SUSPENSION UNITS AND CHAINGUARD

Ref. No.	Part No.	DESCRIPTION	3TA	5TA	T90	T100SS
SWINGING FORK, SUSPENSION UNITS AND CHAINGUARD						
1	F4190	SWINGING FORK	1	1	1	1
2	F4076	Pivot bush	2	2	2	2
3	F4195	Spindle	1	1	1	1
4	F4078	Spacing washer	1	1	1	1
5	F4385	Shim 0.003 in.	as required			
5	F4386	Shim 0.005 in.	as required			
6	F3797	Retainer rod	1	1	1	1
7	F4196	Cap	2	2	2	2
8	F3799	Nut	2	2	2	2
9	64053946	SUSPENSION UNIT	2	-	2	2
10	9054/316A	Bonded bush	4	4	4	4
11	9054/171	Spring retainer	4	4	4	4
12	9054/151	Outer dirt shield	2	2	2	2
13	9054/47	Inner dirt shield	2	2	2	2
14	64539963	Spring, 130 lbs. Red/Orange	2	2	2	2
14	9054/277	Spring, 110 lbs. Red/Red	A	A	A	A
14	SA253/5	Spring, 145 lbs. Blue/Yellow	A	A	A	A
15	E2113	Unit fixing bolt (1 1/8 in. U.H.)	4	4	4	4
16	F2184	Plain washer	2	2	2	2
17	S26-1	Spring washer	2	2	2	2
18	PO172A	Nut	2	2	2	2
19	F5409	Upper chainguard	1	1	1	1
20	DS57	Bolt (7/8 in. U.H.)	1	1	1	1
21	S26-2	Spring washer	1	1	1	1
22	F4134	Front bracket	1	1	1	1
23	F4135	Pivot bolt	1	1	1	1
24	F2277	Spring washer	1	1	1	1
25	S25-13	Plain washer	2	2	2	2
26	E5269	Nut	1	1	1	1
27	F4136	Stepped bolt	1	1	1	1
28	S25-3	Plain washer	1	1	1	1
29	S1-51	Nut	1	1	1	1
30	F4199	Lower chainguard	1	1	-	-
31	W840	Bolt (17/32 in. U.H.)	1	1	1	1
32	E2288	Serrated washer	1	1	1	1
33	DS47	Nut	1	1	1	1
34	PCW73A	Spring washer	1	1	1	1
35	F3597	Brake operating rod	1	1	1	1
36	1/8 in. x 3/8 in.	Split pin	1	1	1	1
37	F4585	Adjuster nut	1	1	1	1
38	F4201	Brake torque stay	-	-	1	1
39	F6046	Front chainguard	-	-	1	1
40	31383	Stop lamp switch, type 22 B	1	1	1	1
41	T1076	Bolt (3/8 in. U.H.)	3	3	3	3
42	F4717	Self locking nut	5	5	5	5
43	F5687	Lever	1	1	1	1
44	3/32in. x 7/8 in.	Split pin	1	1	1	1
45	F5413	"D" washer	1	1	1	1

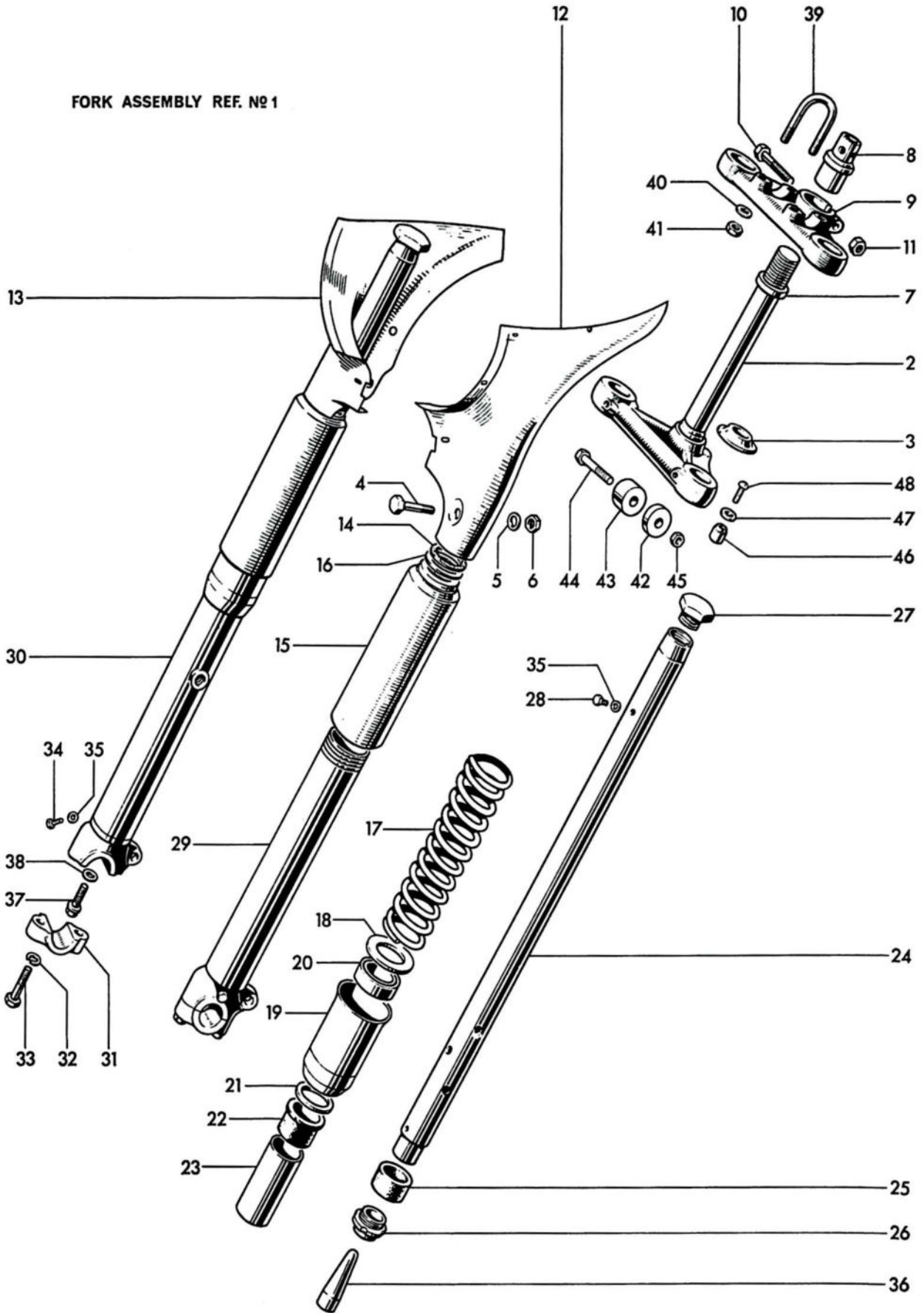

Fig. 14. TELESCOPIC FRONT FORK, 3TA AND 5TA

Ref. No.	Part No.	DESCRIPTION	QUANTITY
TELESCOPIC FRONT FORK, 3TA AND 5TA			
			3TA 5TA
1	H1915	FORK ASSEMBLY	1 1
2	H1665	Middle lug and stem	1 1
3	H1110	Bottom cone	1 1
4	H941	Pinch bolt (2¼ in. U.H.)	2 2
5	S25-2	Plain washer	2 2
6	E2412	Nut	2 2
7	H1667	Distance piece	1 1
8	H1141	Fork stem sleeve nut	1 1
9	H1108	Top lug	1 1
10	F1760	Pinch bolt (1 1/8 in. U.H.)	1 1
11	H379	Seated nut	1 1
12	H1290	Left nacelle cover	1 1
13	H1291	Right nacelle cover	1 1
14	F4047	Cork washer	2 2
15	H1916	Upper cover tube	2 2
16	H1745	Plain washer	2 2
17	H1891	Main spring (Yellow/Blue)	2 2
18	H1656	Plain washer	2 2
19	H1654	DUST EXCLUDER SLEEVE NUT	2 2
20	H1500	Oil seal	2 2
21	H431	Plain washer	2 2
22	H441	Top bearing	2 2
23	H1896	Damping sleeve	2 2
24	H1890	STANCHION c/w BEARING	2 2
25	H443	Lower bearing	2 2
26	H1058	Bearing nut	2 2
27	H1659	Cap nut	2 2
28	H519A	Oil filler plug (3/8 in. U.H.)	2 2
29	H1842	LEFT BOTTOM MEMBER c/w CAP	1 1
30	H1843	RIGHT BOTTOM MEMBER c/w CAP	1 1
31	H1844	Spindle cap	2 2
32	S26-3	Spring washer	4 4
33	H1070	Cap bolt (1 7/8 in. U.H.)	4 4
34	H1071	Drain plug	2 2
35	H430	Fibre washer	4 4
36	H1499	Restrictor	2 2
37	H1063	Flanged bolt (23/32 in. U.H.)	2 2
38	H1062	Aluminium washer	2 2
39	H660	Handlebar "U" bolt	2 2
40	S25-3	Plain washer	4 4
41	E1310	Nut	4 4
42	F5075	Left steering stop	1 1
43	F5076	Right steering stop	1 1
44	F2398	Bolt (1¼ in. U.H.)	1 1
45	S1-51	Nut	1 1
46	F5077	Fork steering stop	1 1
47	S25-1	Plain washer	1 1
48	F5078	Screw (5/8 in. U.H.)	1 1

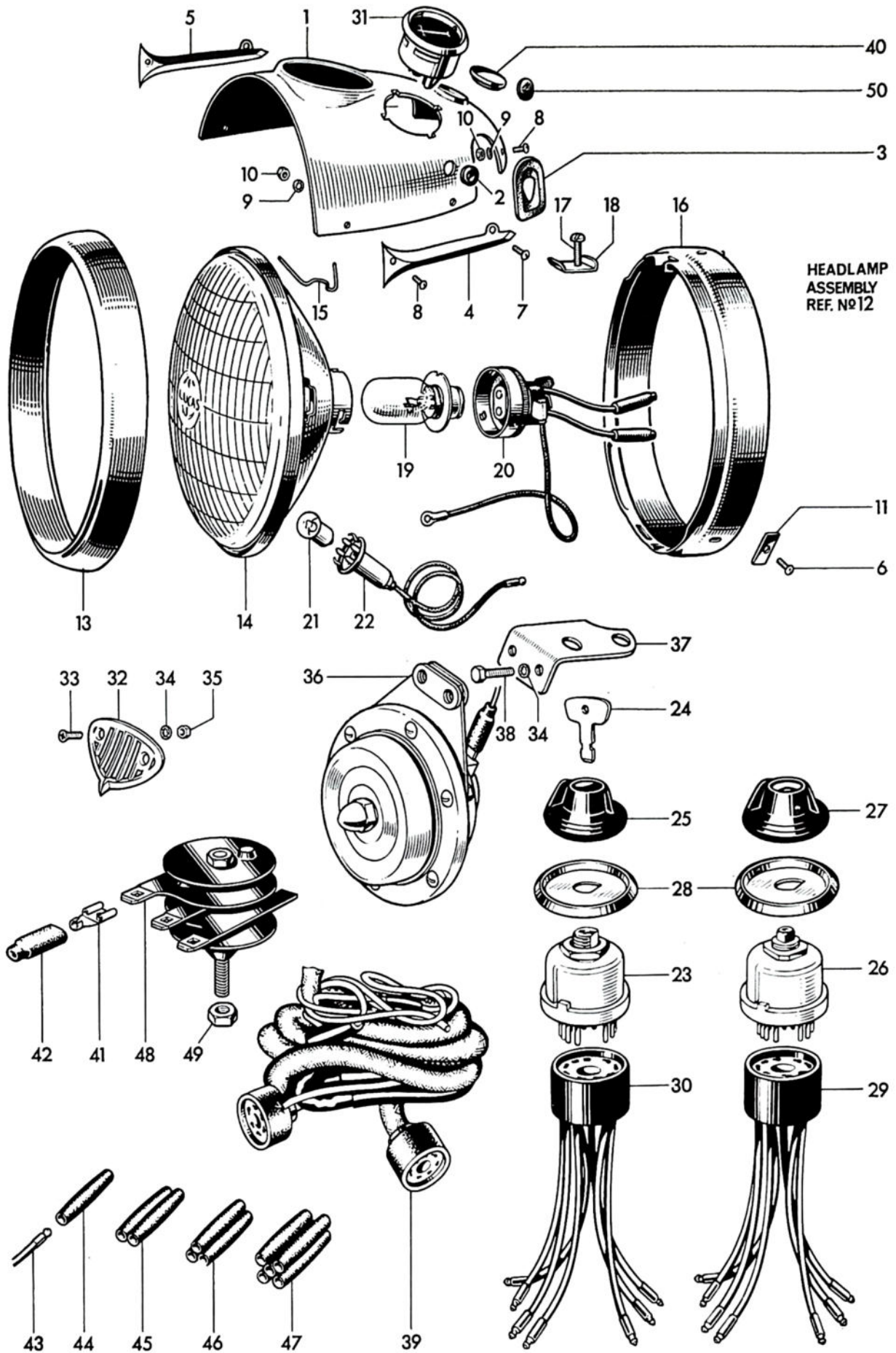

Fig. 15. NACELLE, HEADLAMP AND SWITCHES

Ref. No.	Part No.	DESCRIPTION	QUANTITY
			3TA 5TA
1	H1781	Nacelle top	1 1
2	H1971	Rubber grommet	1 1
3	H669	Rubber grommet	2 2
4	H877	Left motif	1 1
5	H878	Right motif	1 1
6	H689	Screw (1/4 in. U.H.)	4 4
7	H687	Screw (3/8 in. U.H.)	2 2
8	H688	Screw (7/8 in. U.H.)	2 2
9	E2880	Serrated washer	4 4
10	H691	Nut	4 4
11	H690	Nut	2 2
12	51860	HEADLAMP	1 1
13	553248	Rim	1 1
14	516812	Light unit	1 1
15	504665	Fixing wire	6 6
16	553267	Fixing ring	1 1
17	144921	Screw	1 1
18	534296	Plate	1 1
19	373	Bulb (30/24 W. L.H. Dipping. Pre-focus)	1 1
20	554602	Adaptor	1 1
21	988	Bulb (3W.M.C.C.)	1 1
22	554710	Pilot bulbholder	1 1
23	34427	IGNITION SWITCH c/w KEY, type 88SA	1 1
24	54336176	Ignition key	1 1
25	54336178	Ignition switch cover	1 1
26	34289	Lighting switch, type 88SA	1 1
27	54330934	Knob c/w screw	1 1
28	54330576	Switch bezel plate	1 1
29	54930007	Replacement harness socket (Lighting)	A A
30	54930008	Replacement harness socket (Ignition)	A A
31	36296	Ammeter, type 2AR	1 1
32	H992	Horn grille	1 1
33	H993	Screw (0.540 in. U.H.)	2 2
34	GS299	Serrated washer	4 4
35	F3799	Nut	2 2
36	70163	Horn type 8H	1 1
37	H1420	Horn bracket	1 1
38	F4771	Bolt (1/2 in. U.H.)	2 2
39	54933695	Wiring harness	1 1
40	H1421	Rubber grommet	1 1
41	54942078	Lucar connector	5 5
42	54190042	Insulating cover	5 5
43	900269	Snap connector terminal	as required
44	900288	Single snap connector	as required
45	850641	Double snap connector	as required
46	850844	Triple snap connector	as required
47	850832	Quintuple snap connector	as required
48	49072	Rectifier, type 2DS506	1 1
49	F5338	Nut (156596)	1 1
50	H1938	Blind grommet	2 2

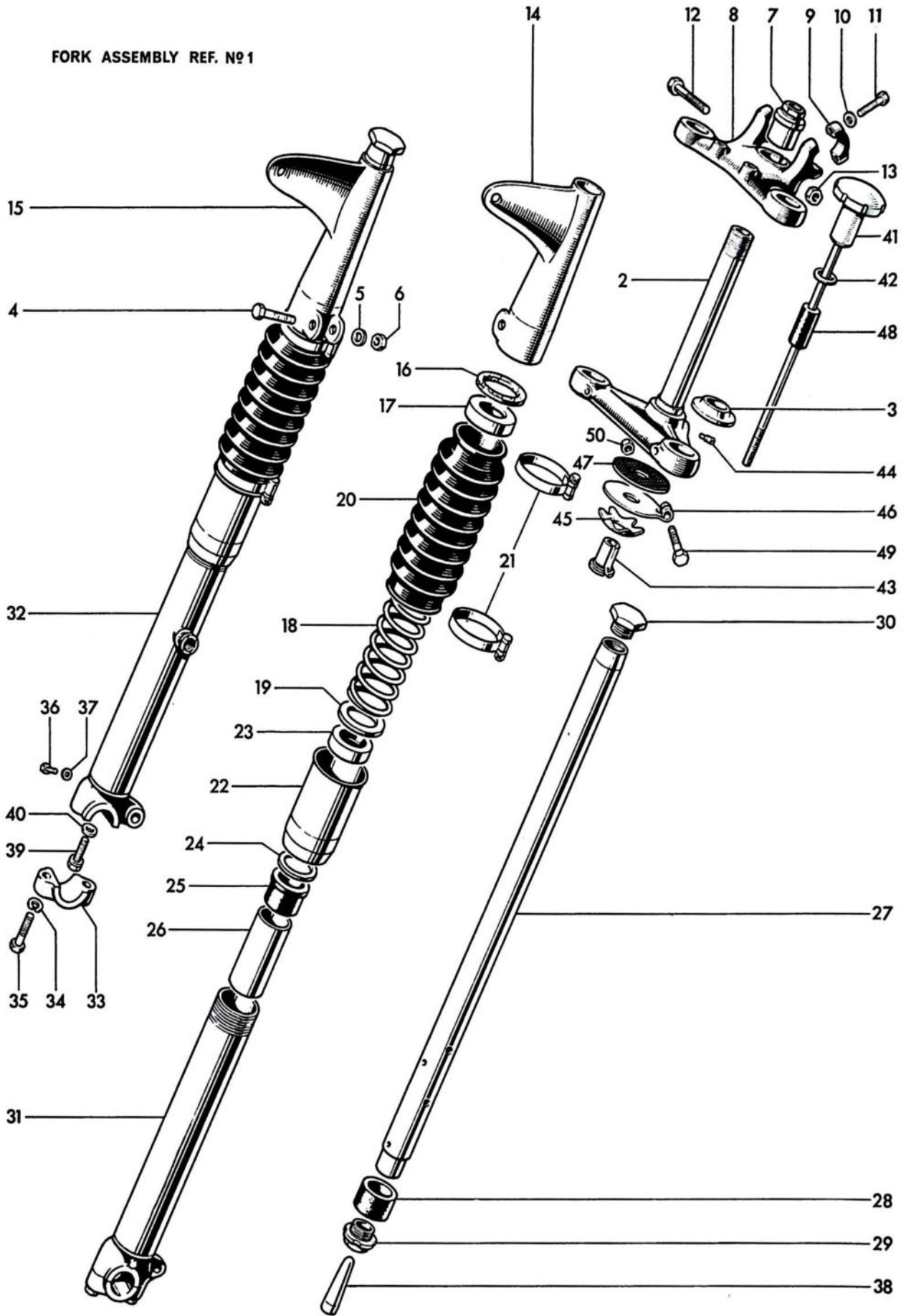

Fig. 16. TELESCOPIC FRONT FORK, T90 AND T100SS

Ref. No.	Part No.	DESCRIPTION	QUANTITY
TELESCOPIC FRONT FORK, T90 AND T100SS			
			T90 T100SS
1	H1918	FORK ASSEMBLY	1 1
2	H1328	Middle lug and stem	1 1
3	H1110	Bottom cone	1 1
4	H941	Pinch bolt (2¼ in. U.H.)	2 2
5	S25-2	Plain washer	2 2
6	H1335	Nut (2⅜ in. O.A.) used with 3½ gallon tank	2 2
6	H1329	Nut (1 ½ in. O.A.) used with 2½ gallon tank	A A
7	H405	Fork stem sleeve nut	1 1
8	H1287	TOP LUG c/w CAPS	1 1
9	H506	Handlebar cap	2 2
10	S25-3	Plain washer	4 4
11	H1340	Bolt (1⅛ in. U.H.)	4 4
12	F1760	Pinch bolt (1 ½ in. U.H.)	1 1
13	H379	Seated nut	1 1
14	H1888	Left cover	1 1
15	H1887	Right cover	1 1
16	F4047	Cork washer	2 2
17	H1657	Spring abutment	2 2
18	H1891	Main spring (Yellow/Blue)	2 2
19	H1656	Plain washer	2 2
20	H1645	Telescopic gaiter	2 2
21	D340	Clip	4 4
22	H1654	DUST EXCLUDER SLEEVE NUT	2 2
23	H1500	Oil seal	2 2
24	H431	Plain washer	2 2
25	H441	Top bearing	2 2
26	H1896	Damping sleeve	2 2
27	H1890	STANCHION c/w BEARING	2 2
28	H443	Lower bearing	2 2
29	H1058	Bearing nut	2 2
30	H1658	Cap nut	2 2
31	H1842	LEFT BOTTOM MEMBER c/w CAP	1 1
32	H1843	RIGHT BOTTOM MEMBER c/w CAP	1 1
33	H1844	Spindle cap	2 2
34	S26-3	Spring washer	4 4
35	H1070	Bolt (1 ⅞ in. U.H.)	4 4
36	H1071	Drain plug	2 2
37	H430	Fibre washer	2 2
38	H1499	Restrictor	2 2
39	H1063	Flanged bolt (23/32 in. U.H.)	2 2
40	H1062	Aluminium washer	2 2
41	H1142	Steering damper rod	1 1
42	H565	Plain washer	1 1
43	H408	Adjuster sleeve	1 1
44	H1286	Locating pin	1 1
45	H95	Spring plate	1 1
46	H1111A	Anchor plate	1 1
47	H435	Friction disc	1 1
48	H1618	Rubber sleeve	1 1
49	F3468	Bolt (2¼ in. U.H.)	1 1
50	S1-51	Nut	1 1

ASSEMBLY REF. No. 1

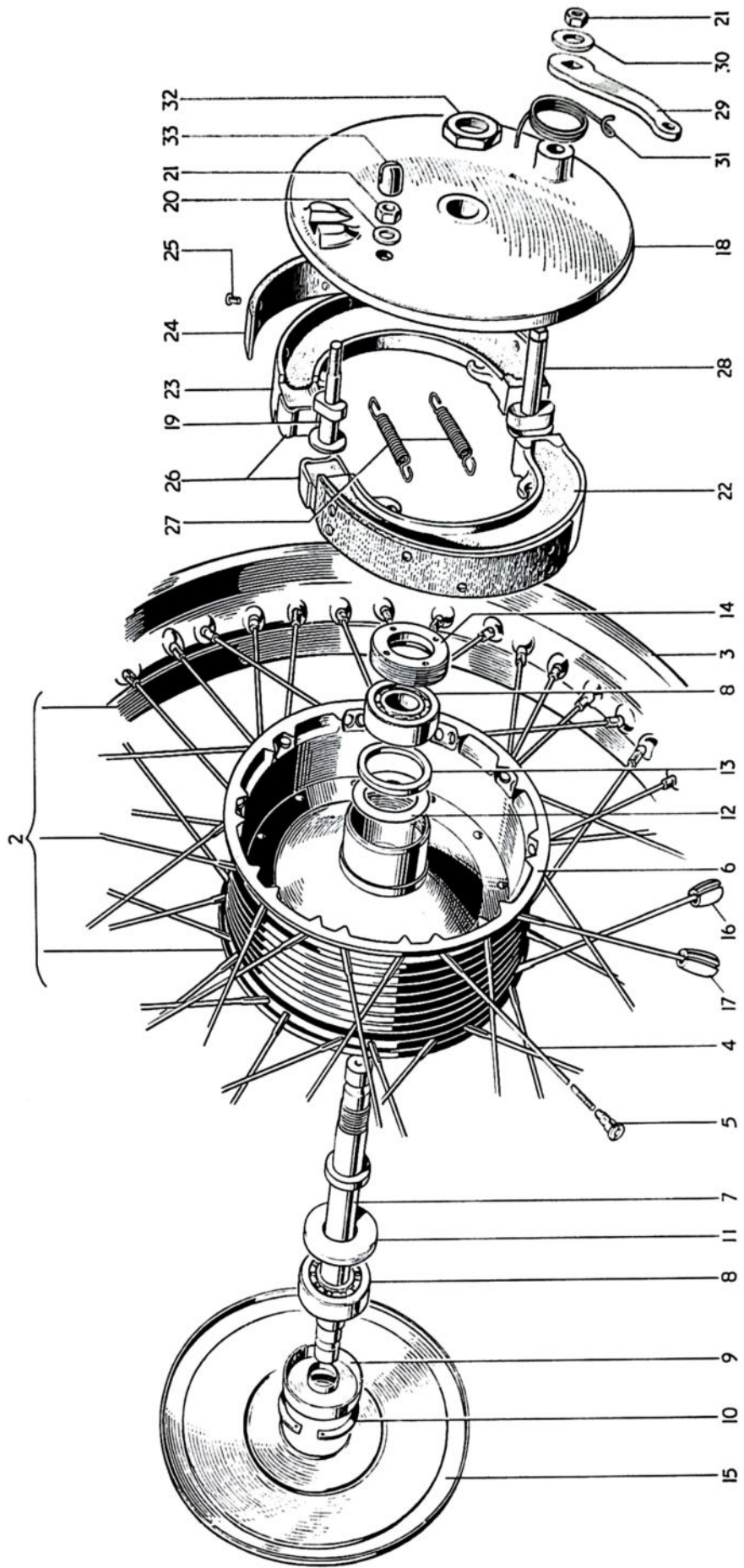

Fig. 17. FRONT WHEEL

FRONT WHEEL

							3TA	5TA	T90	T100SS
1	W1660	FRONT WHEEL COMPLETE	1	1	-	-
1	W1664	FRONT WHEEL COMPLETE	-	-	1	1
2	W1273	RIM, SPOKES AND HUB ASSEMBLY	1	1	-	-
2	W1370	RIM, SPOKES AND HUB ASSEMBLY	-	-	1	1
3	W1274	Front wheel rim (WM2-17)	1	1	-	-
3	W1373	Front wheel rim (WM2-18)	-	-	1	1
4	W1275	Spoke (8/10G x 5 $\frac{1}{8}$ in. straight) c/w nipple	40	40	-	-
4	W1497	Spoke (8/10G x 5 $\frac{5}{8}$ in. straight) c/w nipple	-	-	40	40
5	S79-2	Spoke nipple	40	40	40	40
6	W1231	Hub and brake drum	1	1	1	1
7	W1641	Wheel spindle	1	1	1	1
8	W653	Bearing	2	2	2	2
9	W1237	Dust cover	1	1	1	1
10	T280	Circlip	1	1	1	1
11	W1481	Grease retainer	1	1	1	1
12	W1474	Grease retainer (Brake side)	1	1	1	1
13	W1238	Backing ring	1	1	1	1
14	W582	Retaining ring	1	1	1	1
15	W1334	Cover plate	1	1	1	1
16	W1197	Balance weight, $\frac{1}{2}$ oz.	as required			
17	W1198	Balance weight, 1 oz.	as required			
18	W1301	Brake anchor plate	1	1	1	1
19	W1639	Fulcrum pin	1	1	1	1
20	S25-2	Plain washer	1	1	1	1
21	S1-52	Nut	2	2	2	2
22	W1406	LEADING BRAKE SHOE C/W LINING	1	1	1	1
23	W1407	TRAILING BRAKE SHOE C/W LINING	1	1	1	1
24	NW243	Brake lining	2	2	2	2
25	W129	Brass rivet	16	16	16	16
26	W1415	Thrust pad	2	2	2	2
27	W135	Shoe return spring	2	2	2	2
28	W1243	Brake cam	1	1	1	1
29	W1331	Brake cam lever	1	1	1	1
30	S25-6	Plain washer	1	1	1	1
31	W592	Lever return spring	1	1	1	1
32	W1246	Anchor plate nut	1	1	1	1
33	W1640	Abutment	1	1	1	1

ASSEMBLY REF. No. 1

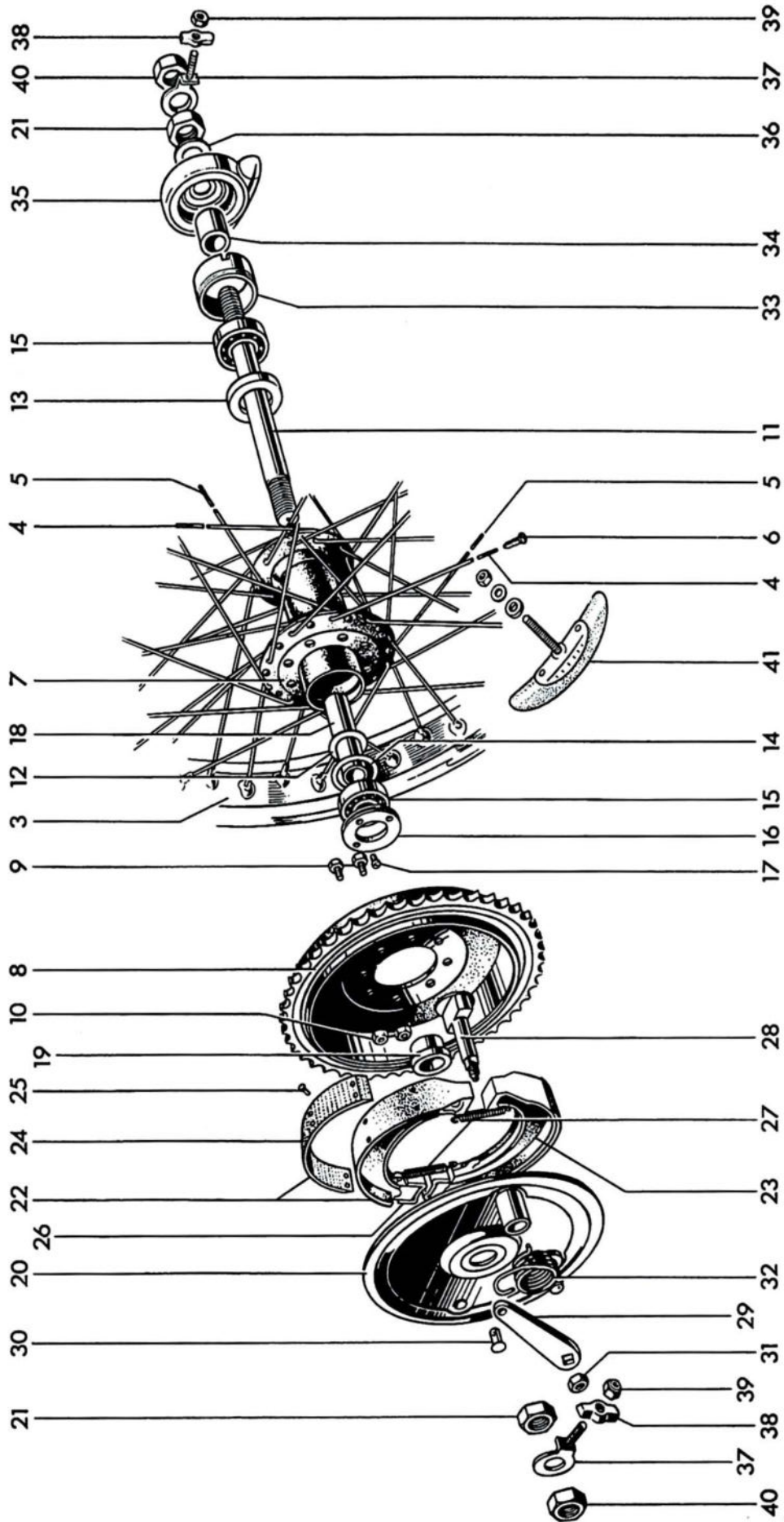

Fig. 18. REAR WHEEL

Ref. No.	Part No.	DESCRIPTION	3TA	5TA	T90	T100SS
REAR WHEEL						
1	W1579	REAR WHEEL COMPLETE	1	1	-	-
1	W1484	REAR WHEEL COMPLETE	-	-	1	1
2	W1483	RIM, SPOKES AND HUB ASSEMBLY	1	1	-	-
2	W1470	RIM, SPOKES AND HUB ASSEMBLY	-	-	1	1
3	W1435	Rear wheel rim WM2-17	1	1	-	-
3	W1471	Rear wheel rim WM2-18	-	-	1	1
4	W1271	Spoke (8/10G x 7 $\frac{1}{8}$ in.90°) c/w nipple	20	20	-	-
4	W1107	Spoke (8/10G x 7 $\frac{7}{8}$ in.90°) c/w nipple	-	-	20	20
5	W1377	Spoke (8/10G x 7 $\frac{3}{8}$ in.90°) c/w nipple	20	20	-	-
5	W1108	Spoke (8/10G x 7 $\frac{7}{8}$ in.90°) c/w nipple	-	-	20	20
6	S79-2	Spoke nipple	40	40	40	40
7	W1472	Hub	1	1	1	1
8	W951	Sprocket and brake drum 46T	1	1	1	1
9	W62	Sprocket to hub bolt ($\frac{1}{2}$ in. U.H.)	8	8	8	8
10	W1495	Self locking nut	8	8	8	8
11	W1281	Wheel spindle	1	1	1	1
12	W1474	Grease retainer (brake side)	1	1	1	1
13	W1654	Grease retainer	1	1	1	1
14	W1022	Backing ring	1	1	1	1
15	W653	Bearing	2	2	2	2
16	W1021	RETAINING RING	1	1	1	1
17	W1079	Locking screw ($\frac{7}{8}$ in. U.H.)	1	1	1	1
18	W1278	Distance tube	1	1	1	1
19	W1024	Distance piece	1	1	1	1
20	W1112	Brake anchor plate	1	1	1	1
21	W1282	Nut	2	2	2	2
22	W1406	LEADING BRAKE SHOE C/W LINING	1	1	1	1
23	W1407	TRAILING BRAKE SHOE C/W LINING	1	1	1	1
24	NW243	Brake lining	2	2	2	2
25	W129	Brass rivet	16	16	16	16
26	W1415	Thrust pad	2	2	2	2
27	W135	Shoe return spring	2	2	2	2
28	W1083	Brake cam	1	1	1	1
29	W1466	Brake cam lever	1	1	1	1
30	W1467	Pivot pin	1	1	1	1
31	S1-52	Nut	1	1	1	1
32	W1090	Lever return spring	1	1	1	1
33	W1476	Speedometer adaptor	1	1	1	1
34	W1477	Distance piece	1	1	1	1
35	D544	Speedometer gearbox (green washer)	1	1	-	-
35	D373	Speedometer gearbox	-	-	1	1
36	W1280	Plain washer	1	1	1	1
37	W1134	Chain adjuster	2	2	2	2
38	W1015	Adjuster end plate	2	2	2	2
39	W1058	Self-locking nut	2	2	2	2
40	F1747	Spindle nut	2	2	2	2
41	D106	Tyre security bolt	-	-	2	2

ASSEMBLY REF. No. 1

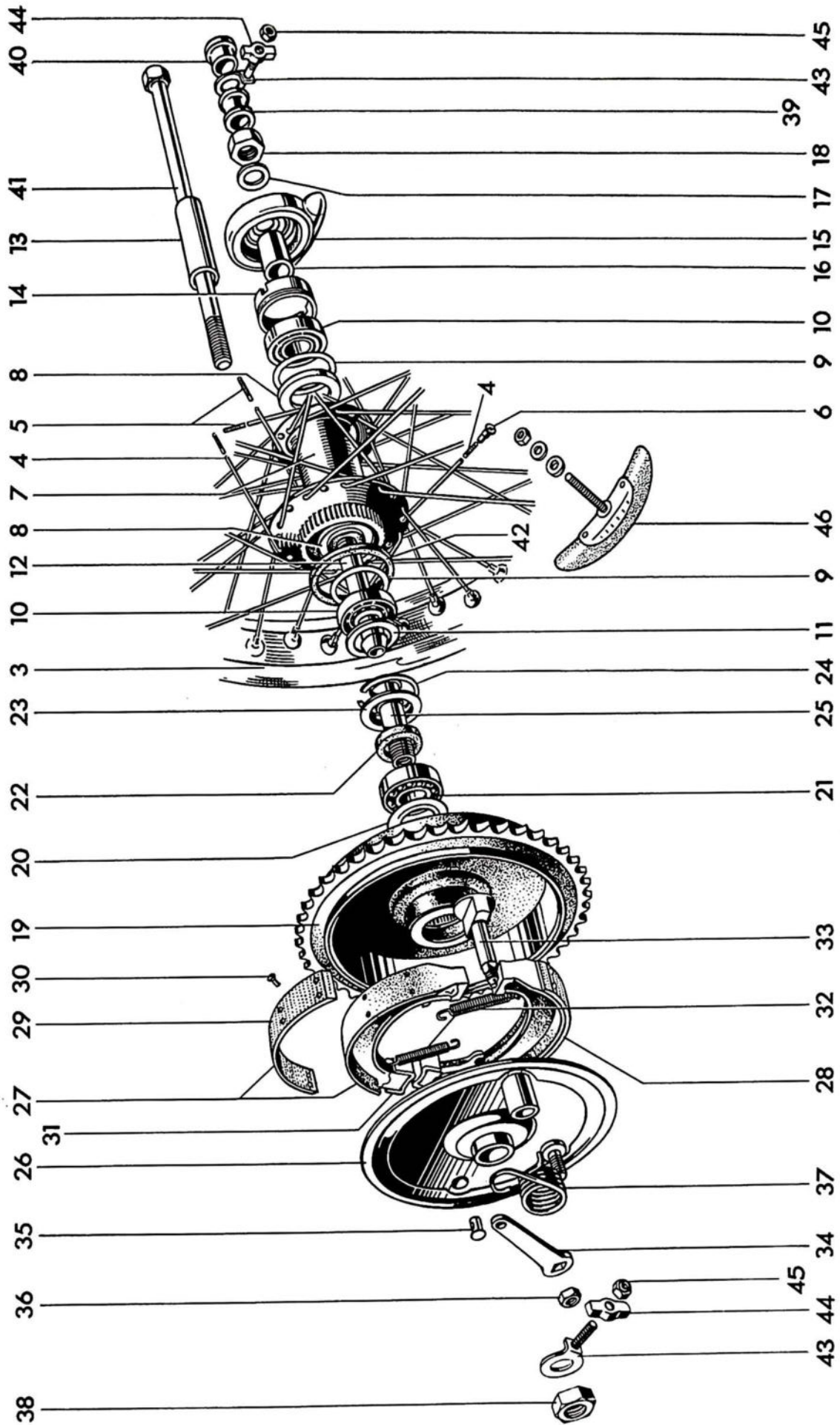

Fig. 19. QUICKLY DETACHABLE REARWHEEL

Ref. No.	Part No.	DESCRIPTION	3TA	5TA	T90	T100SS
QUICKLY DETACHABLE REAR WHEEL						
1	W1601	Q.D. REAR WHEEL COMPLETE	1	1	-	-
1	W1602	Q.D. REAR WHEEL COMPLETE	-	-	1	1
2	W1604	RIM, SPOKES AND HUB ASSEMBLY	1	1	-	-
2	W1603	RIM, SPOKES AND HUB ASSEMBLY	-	-	1	1
3	W1435	Rear wheel rim WM2-17	1	1	-	-
3	W1007	Rear wheel rim WM3-18	-	-	1	1
4	W1271	Spoke (8/10G x 7 $\frac{1}{8}$ in.90°) c/w nipple	20	20	-	-
4	W1107	Spoke (8/10G x 7 $\frac{7}{8}$ in.90°) c/w nipple	-	-	20	20
5	W1377	Spoke (8/10G x 7 $\frac{3}{8}$ in.90°) c/w nipple	20	20	-	-
5	W1108	Spoke (8/10G x 7 $\frac{7}{8}$ in.90°) c/w nipple	-	-	20	20
6	S79-2	Spoke nipple	40	40	40	40
7	W1593	Hub	1	1	1	1
8	W1595	Grease retainer	2	2	2	2
9	W1509	Backing ring	2	2	2	2
10	S35-7	Bearing	2	2	2	2
11	W1596	Dust cap	1	1	1	1
12	W1614	Bearing sleeve	1	1	1	1
13	W1598	Distance piece (inner)	2	2	2	2
14	W1477	Distance piece (outer)	1	1	1	1
15	D544	Speedometer gearbox (green washer)	1	1	-	-
15	D373	Speedometer gearbox	-	-	1	1
16	W1280	Plain washer	1	1	1	1
17	W1282	Nut	1	1	1	1
18	W1091	Rubber sealing ring	1	1	1	1
19	W1040	Sprocket and brake drum 46T	1	1	1	1
20	W1143	Grease retainer	1	1	1	1
21	W1041	Bearing	1	1	1	1
22	W1042	Felt washer	1	1	1	1
23	W1043	Bearing and felt retainer	1	1	1	1
24	W1044	Circlip	1	1	1	1
25	W1045	Bearing sleeve	1	1	1	1
26	W1395	Brake anchor plate	1	1	1	1
27	W1046	LEADING BRAKE SHOE C/W LINING	1	1	1	1
28	W1407	TRAILING BRAKE SHOE C/W LINING	1	1	1	1
29	NW243	Brake lining	2	2	2	2
30	W129	Brass rivet	16	16	16	16
31	W1415	Thrust pad	2	2	2	2
32	W135	Shoe return spring	2	2	2	2
33	W1083	Brake cam	1	1	1	1
34	W1466	Brake cam lever	1	1	1	1
35	W1467	Pivot pin	1	1	1	1
36	S1-52	Nut	1	1	1	1
37	W1090	Lever return spring	1	1	1	1
38	W1052	Nut	1	1	1	1
39	W1392	Inner distance piece	1	1	1	1
40	W1170	Outer distance piece	1	1	1	1
41	W1055	Spindle	1	1	1	1
42	W1135	Chain adjuster	2	2	2	2
43	W1015	Adjuster end plate	2	2	2	2
44	W1058	Self-locking nut	2	2	2	2
45	WM3	Tyre security bolt	-	-	1	1

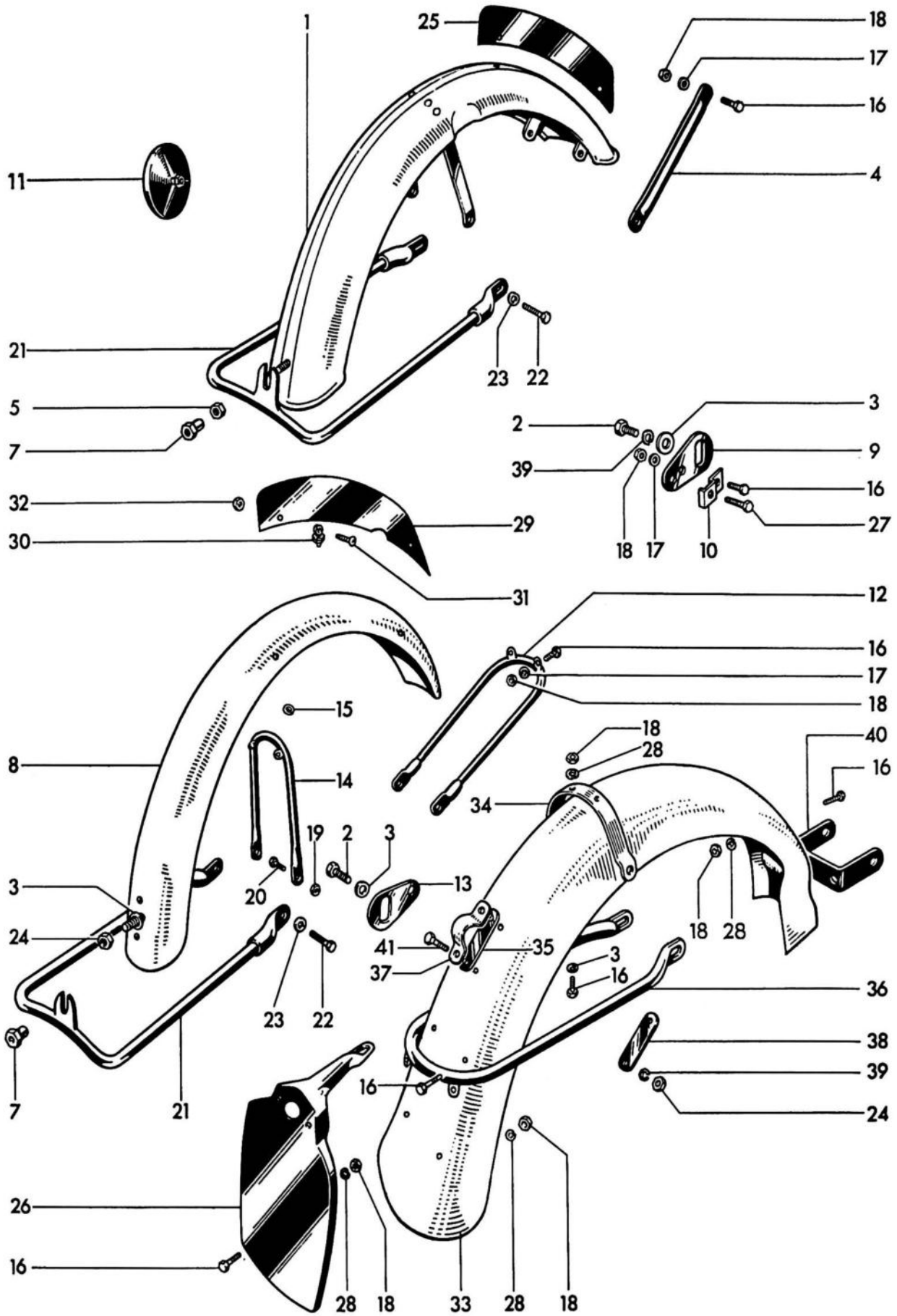

Fig. 20. MUDGUARDS

Ref. No. Part No. DESCRIPTION

MUDGUARDS

3TA 5TA T90 T100SS

Ref. No.	Part No.	DESCRIPTION	3TA	5TA	T90	T100SS
1	H1901	Front mudguard	1	1	-	-
2	F929	Bolt (½ in. U.H.)	2	2	2	2
3	F4299	Plain washer	5	5	5	5
4	H1964	Front stay	2	2	-	-
5	H1904	Nut	1	1	-	-
6	S25-3	Plain washer	2	2	-	-
7	NS362	Spigot nut	1	1	1	1
8	H1675	Mudguard blade	-	-	1	1
9	H1878	Bracket	2	2	-	-
10	H1879	Clip	2	2	-	-
11	D261	Licence holder	1	1	1	1
12	H1681	Front stay	-	-	1	1
13	H1685	Bracket	-	-	2	2
14	H1683	Mudguard bridge	-	-	1	1
15	WE170	Fibre washer	-	-	2	2
16	DS57	Bolt (¾ in. U.H.)	12	12	10	10
17	S25-1	Plain washer	7	7	6	6
18	F879	Nut	17	17	12	12
19	T224	Nut	-	-	2	2
20	DS55	Bolt (½ in. U.H.)	-	-	2	2
21	H1482	Bottom stay	-	-	1	1
22	H424	Bolt (39/64 in. U.H.)	-	-	2	2
23	S25-71	Plain washer	-	-	2	2
24	S1-51	Nut	2	2	3	3
25	F6469	Number plate	1	1	-	-
26	F5924	Number plate	1	1	1	1
27	F1369	Bolt (⅝ in. U.H.)	2	2	-	-
28	S26-2	Spring washer	6	6	6	6
29	F6470	Number plate	-	-	1	1
30	H741	Clip assembly	2	2	2	2
31	H687	Screw (⅜ in. U.H.)	2	2	2	2
32	H745	Nut	2	2	2	2
33	F5963	Mudguard blade	1	1	-	-
33	F5984	Mudguard blade	-	-	1	1
34	F4860	Mudguard bridge	1	1	1	1
35	F5995	Packing strip	1	1	-	-
36	F5424	Lifting handle	1	1	1	1
37	F5994	Clip	1	1	1	1
38	F6031	Backing plate	1	1	1	1
39	S26-3	Spring washer	4	4	2	2
40	F5962	Bracket	1	1	-	-
40	F3599	Bracket	-	-	1	1
41	DS55	Bolt (½ in. U.H.)	2	2	-	-
41	H590	Bolt (⅜ in. U.H.)	-	-	2	2

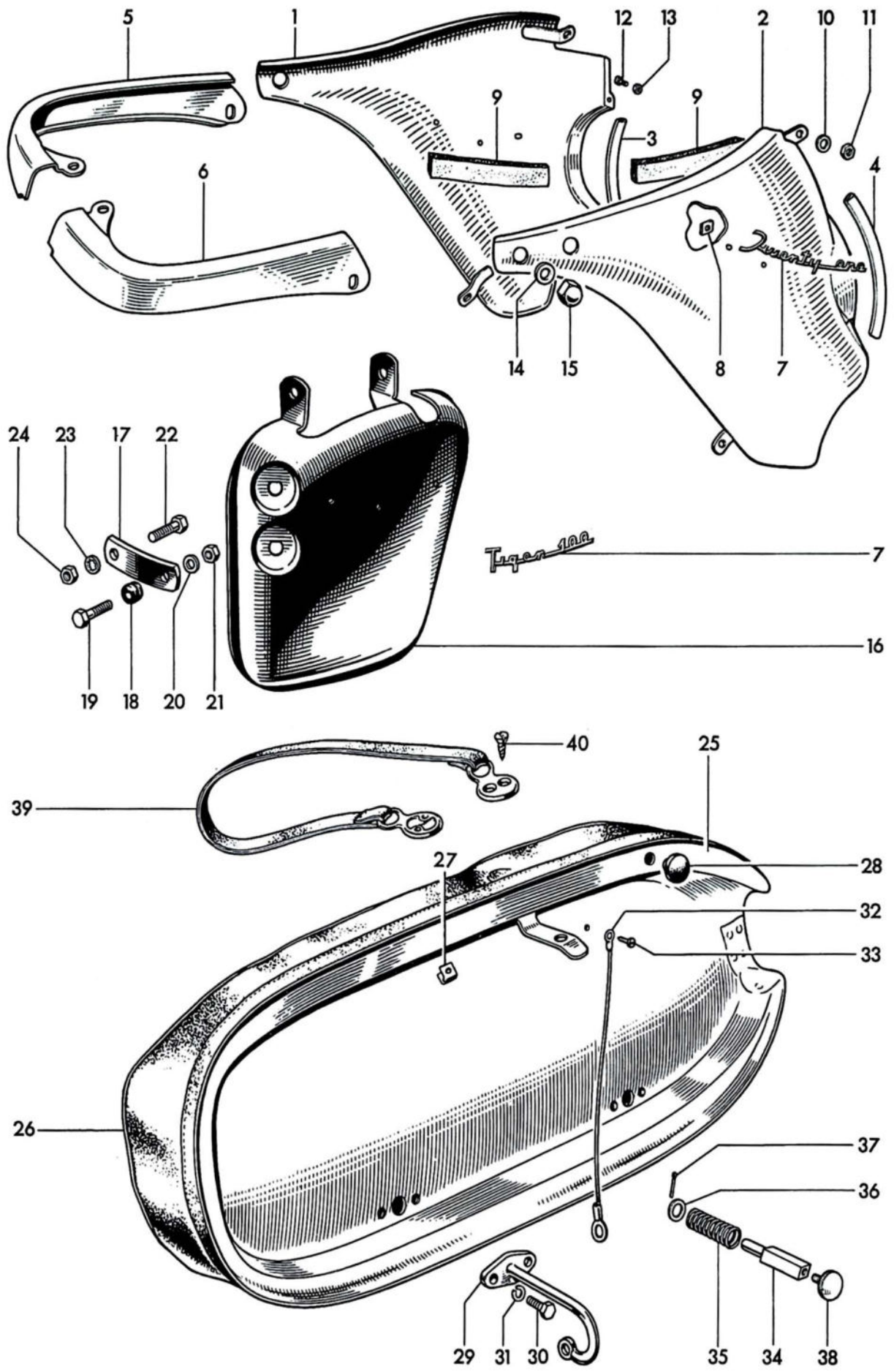

Fig. 21. PANELS AND TWINSEAT

Ref. No.	Part No.	DESCRIPTION	3TA	5TA	T90	T100SS
PANELS AND TWINSEAT						
1	F5978	Left panel	1	1	-	-
2	F5362	Right panel	1	1	-	-
3	F6104	Left beading	1	1	-	-
4	F6105	Right beading	1	1	-	-
5	F5323	Left valance	1	1	-	-
6	F5324	Right valance	1	1	-	-
7	F4312	Motif "Twentyone"	2	-	-	-
7	F4523	Motif "Speed Twin"	-	2	-	-
7	F5372	Motif "Tiger 90"	-	-	1	-
7	F4524	Motif "Tiger 100"	-	-	-	1
8	F4317	Spire nut	6	6	3	3
9	F5538	Rubber pad	2	2	-	-
10	S25-2	Plain washer	2	2	-	-
11	S1-52	Nut	2	2	-	-
12	F4715	Screw (13/32 in. U.H.)	2	2	-	-
13	F4717	Self-locking nut	2	2	-	-
14	GS308	Plain washer	2	2	-	-
15	E4329	Domed nut	2	2	-	-
16	F5559	Switch panel	-	-	1	1
17	F5976	Link	-	-	1	1
18	F5466	Grommet	-	-	1	1
19	F1756	Bolt ($\frac{3}{4}$ in. U.H.)	-	-	1	1
20	S25-43	Plain washer	-	-	1	1
21	E3290	Self-locking nut	-	-	1	1
22	F1369	Bolt ($\frac{1}{2}$ in. U.H.)	-	-	1	1
23	E1612	Serrated washer	-	-	1	1
24	F879	Nut	-	-	1	1
25	F4239	TWINSEAT	1	1	1	1
26	F4244	Twinsseat cover c/w clips	1	1	1	1
27	F4475	Clip	as required			
28	F4898	Rubber buffer	1	1	1	1
29	F4222	Hinge	2	2	2	2
30	DS57	Bolt ($\frac{1}{2}$ in. U.H.)	4	4	4	4
31	S26-2	Spring washer	4	4	4	4
32	D374	Check wire	1	1	1	1
33	F4483	Self-tapping screw	1	1	1	1
34	F4226	Seat catch plunger	1	1	1	1
35	F4228	Spring	1	1	1	1
36	E1719A	Plain washer	1	1	1	1
37	3/32 in. x $\frac{1}{2}$ in.	Split pin	1	1	1	1
38	F4227	Knob	1	1	1	1
39	F4361	Safety strap	as required			
40	F4365	Self-tapping screw	4	4	4	4

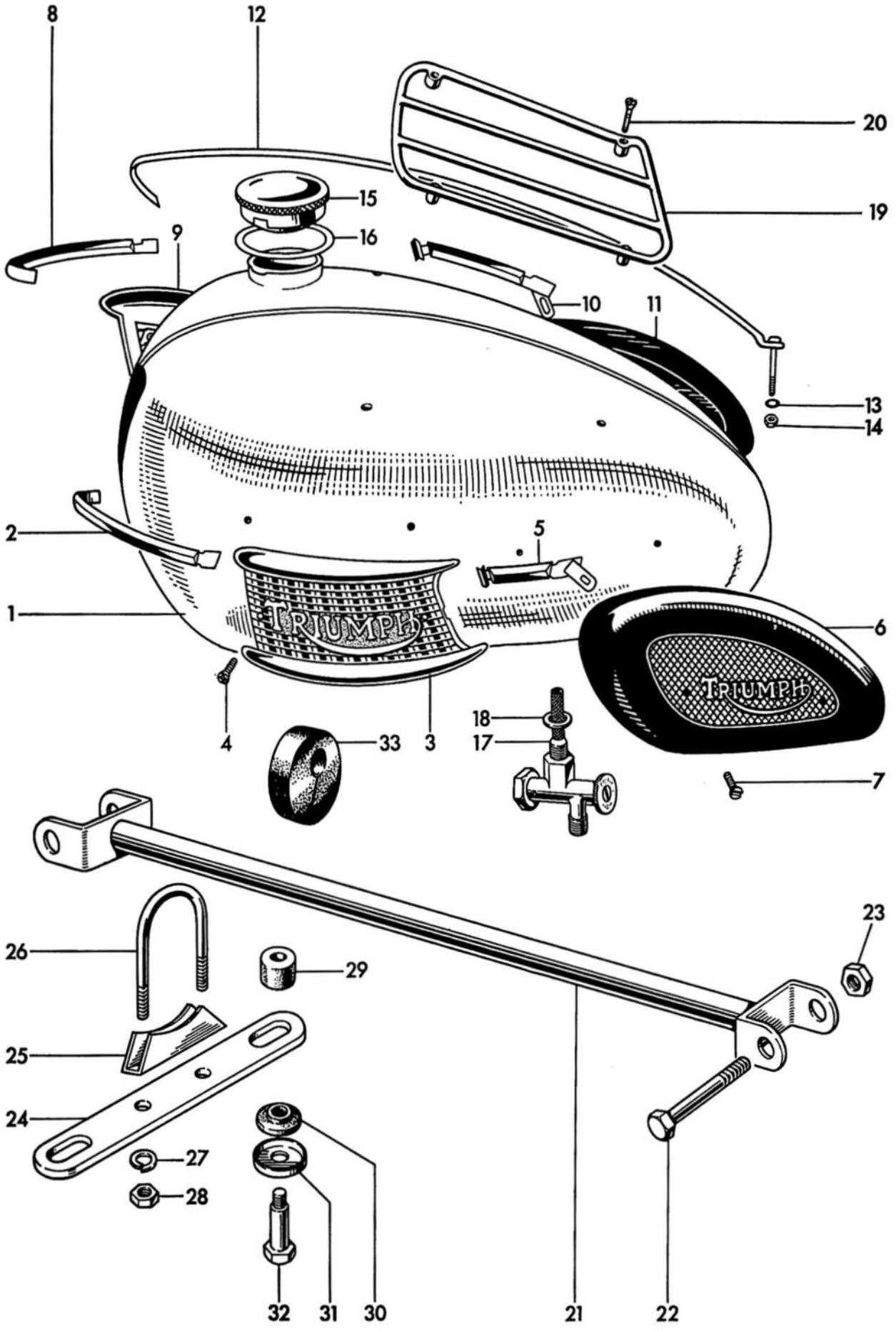

Fig. 22. PETROL TANK

Ref. No.	Part No.	DESCRIPTION	3TA	5TA	T90	T100SS
PETROL TANK						
1	F6140	Petrol tank	1	1	1	1
2	F4235	Styling strip (Left front)	A	A	1	1
3	F4127	Styling unit (Left)	1	1	1	1
4	F4129	Styling unit screw (0.435 in. U.H.)	4	4	4	4
5	F4323	Styling strip (Left rear)	A	A	1	1
6	F2551	Knee grip (Left)	1	1	1	1
7	F1953	Knee grip screw ($\frac{5}{8}$ In. U.H.)	4	4	4	4
8	F4237	Styling strip (Right front)	A	A	1	1
9	F4128	Styling unit (Right)	1	1	1	1
10	F4324	Styling strip (Right rear)	A	A	1	1
11	F2552	Knee grip (Right)	1	1	1	1
12	F6313	Centre styling strip	1	1	1	1
13	F4019	Serrated washer	1	1	1	1
14	H919	Nut	1	1	1	1
15	F3220	FILLER CAP	1	1	1	1
16	F4048	Joint washer	1	1	1	1
17	F1717	Petrol tap	1	1	1	1
18	F1511	Fibre washer	1	1	1	1
19	F3917	Parcel grid	1	1	1	1
20	F2936	Parcel grid screw	4	4	4	4
21	F4862	Frame strut	1	1	1	1
22	E327	Bolt ($3\frac{3}{8}$ in. U.H.)	2	2	2	2
23	F3955	Self locking nut	2	2	2	2
24	F6143	Tank bracket	2	2	2	2
25	F6144	Saddle	2	2	2	2
26	F6145	'U' Bolt	2	2	2	2
27	S26-3	Spring washer	4	4	4	4
28	S1-51	Nut	4	4	4	4
29	F5228	Plain rubber	4	4	4	4
30	F5229	Spigoted rubber	4	4	4	4
31	F3814	Cup	4	4	4	4
32	F1808	Bolt	4	4	4	4
33	F4770	Steady rubber	1	1	1	1

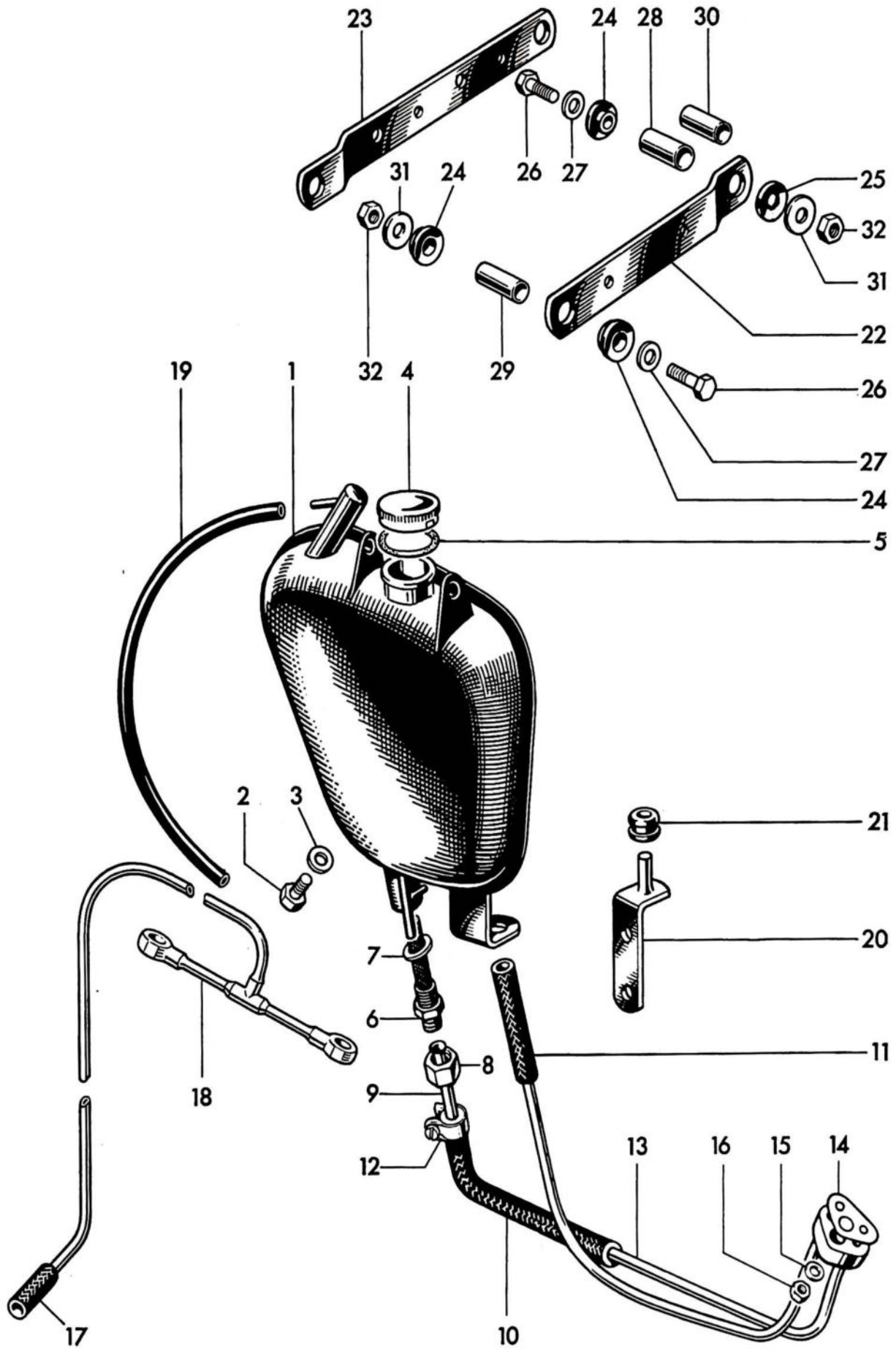

Fig. 23. OIL TANK

Ref. No.	Part No.	DESCRIPTION	3TA	5TA	T90	T100SS
OIL TANK						
1	F5381	Oil tank ...	1	1	1	1
2	F5343	Drain plug	1	1	1	1
3	PT104B	Fibre washer	1	1	1	1
4	F3216	FILLER CAP	1	1	1	1
5	F4047	Joint washer	1	1	1	1
6	F3179	Oil tank filter	1	1	1	1
7	F1713	Fibre washer	1	1	1	1
8	F3182	Union nut	1	1	1	1
9	F6103	Upper feed pipe	1	1	1	1
10	E3353	Flexible connector, long	1	1	1	1
11	MF119	Flexible connector, short	1	1	1	1
12	E5473	Clip	4	4	4	4
13	E5434	Oil pipes and junction block	1	1	1	1
14	E3763	Joint washer	1	1	1	1
15	E3446	Plain washer	1	1	1	1
16	E1310	Nut	1	1	1	1
17	E3383	Rubber connector	1	1	1	1
18	E3805	Rocker oil feed pipe	1	1	1	1
19	T1579	Vent pipe	1	1	1	1
20	F5378	Bottom tank bracket	1	1	1	1
21	F5332	Rubber grommet	1	1	1	1
22	F5328	Front cross-bar	1	1	1	1
23	F5329	Rear cross-bar	1	1	1	1
24	F5247	Spigot rubber	6	6	6	6
25	F5248	Rubber washer	2	2	2	2
26	W932	Bolt (1 in. U.H.)	4	4	4	4
27	S25-13	Plain washer (small)	4	4	4	4
28	F6307	Distance tube (13/32 in. O.A.)	2	2	—	—
29	F6308	Distance tube (17/32 in. O.A.)	2	2	2	2
30	F6309	Distance tube (15/32 in. O.A.)	—	—	2	2
31	F6310	Plain washer (large)	4	4	4	4
32	F879	Nut	4	4	4	4

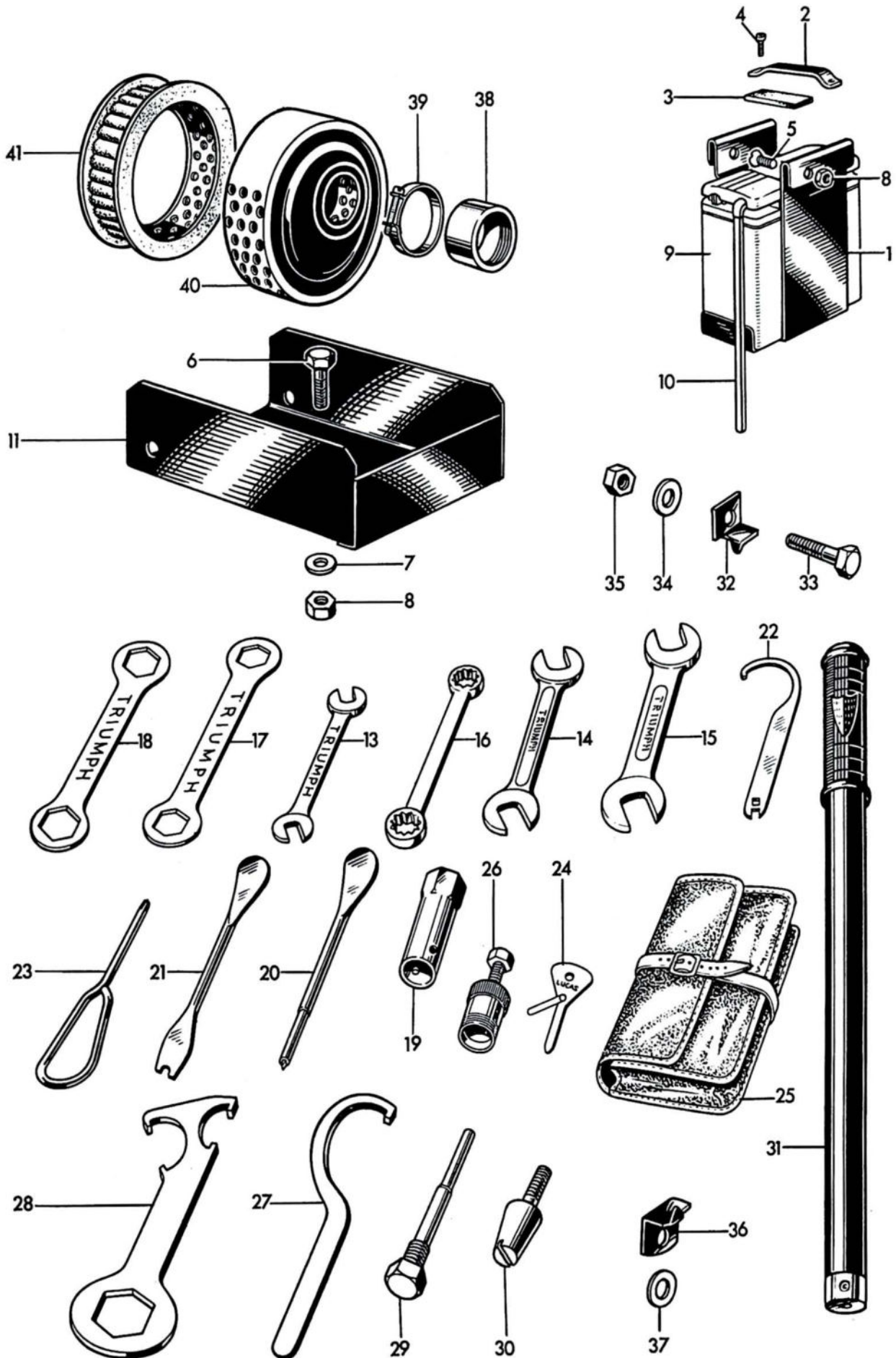

Fig. 24. BATTERY, TOOLKIT AND AIR FILTER

Ref. No.	Part No.	DESCRIPTION	3TA	5TA	T90	T100SS
BATTERY, TOOLKIT AND AIR FILTER						
1	F5333	Battery carrier	1	1	1	1
2	F4661	Top strap	1	1	1	1
3	F4662	Packing rubber	1	1	1	1
4	E3200	Screw ($\frac{1}{4}$ in. U.H.)	1	1	1	1
5	E3728	Screw (15/32 in. U.H.)	1	1	1	1
6	DS57	Bolt ($\frac{7}{8}$ in. U.H.)	3	3	3	3
7	S25-1	Plain washer	3	3	3	3
8	F879	Nut	3	3	3	3
9	MLZ9E	Battery c/w lid	1	1	1	1
10	F4816	Plastic vent pipe	1	1	1	1
11	F5665	Tool tray	1	1	1	1
12	D446	TOOL KIT	1	1	1	1
13	D360	Open spanner, $\frac{1}{8}$ in. x $\frac{5}{32}$ in. whit.	1	1	1	1
14	NA55	Open spanner, $\frac{1}{4}$ in. x $\frac{7}{8}$ in. whit.	1	1	1	1
15	DA16	Open spanner, $\frac{3}{8}$ in. x $\frac{7}{8}$ in. whit.	1	1	1	1
16	D370	Ring spanner, $\frac{7}{8}$ in. x $\frac{1}{4}$ in. whit.	1	1	1	1
17	PA57	Ring spanner, $\frac{1}{2}$ in. x $\frac{7}{8}$ in. whit.	1	1	1	1
18	D311	Ring spanner, $\frac{5}{8}$ in. x $\frac{1}{2}$ in. whit.	1	1	1	1
19	D87	Box spanner, spark plug	1	1	1	1
20	D363	Tyre lever and tommy bar	1	1	1	1
21	D364	Tyre lever and clutch key	1	1	1	1
22	D362	"C" spanner and tappet key	1	1	1	1
23	D336	Phillips No. 3 screwdriver	1	1	1	1
24	400935	Ignition screwdriver and feeler gauge	1	1	1	1
25	WA58	Tool roll	1	1	1	1
26	DA50/1	Clutch hub extractor	A	A	A	A
27	D527	Fork spanner (for sleeve nut)	A	A	A	A
28	D220	Fork spanner (for cap nut)	A	A	A	A
29	D484	Contact breaker extractor	A	A	A	A
30	D486	Contact breaker assembly pilot	A	A	A	A
31	D296	Tyre inflator	1	1	1	1
32	F5432	Inflator top bracket	1	1	1	1
33	F1369	Bolt ($\frac{5}{8}$ in. U.H.)	1	1	1	1
34	S25-43	Plain washer	1	1	1	1
35	S1-40	Nut	1	1	1	1
36	F5433	Inflator bottom bracket	1	1	1	1
37	S25-3	Plain washer	1	1	1	1
38	E5194	Adaptor	1	1	-	-
38	F4812	Adaptor	-	-	1	1
39	F5625	Clip	1	1	1	1
40	F6430	AIR FILTER	1	1	1	1
41	F4811	Filter element (felt)	1	1	1	1

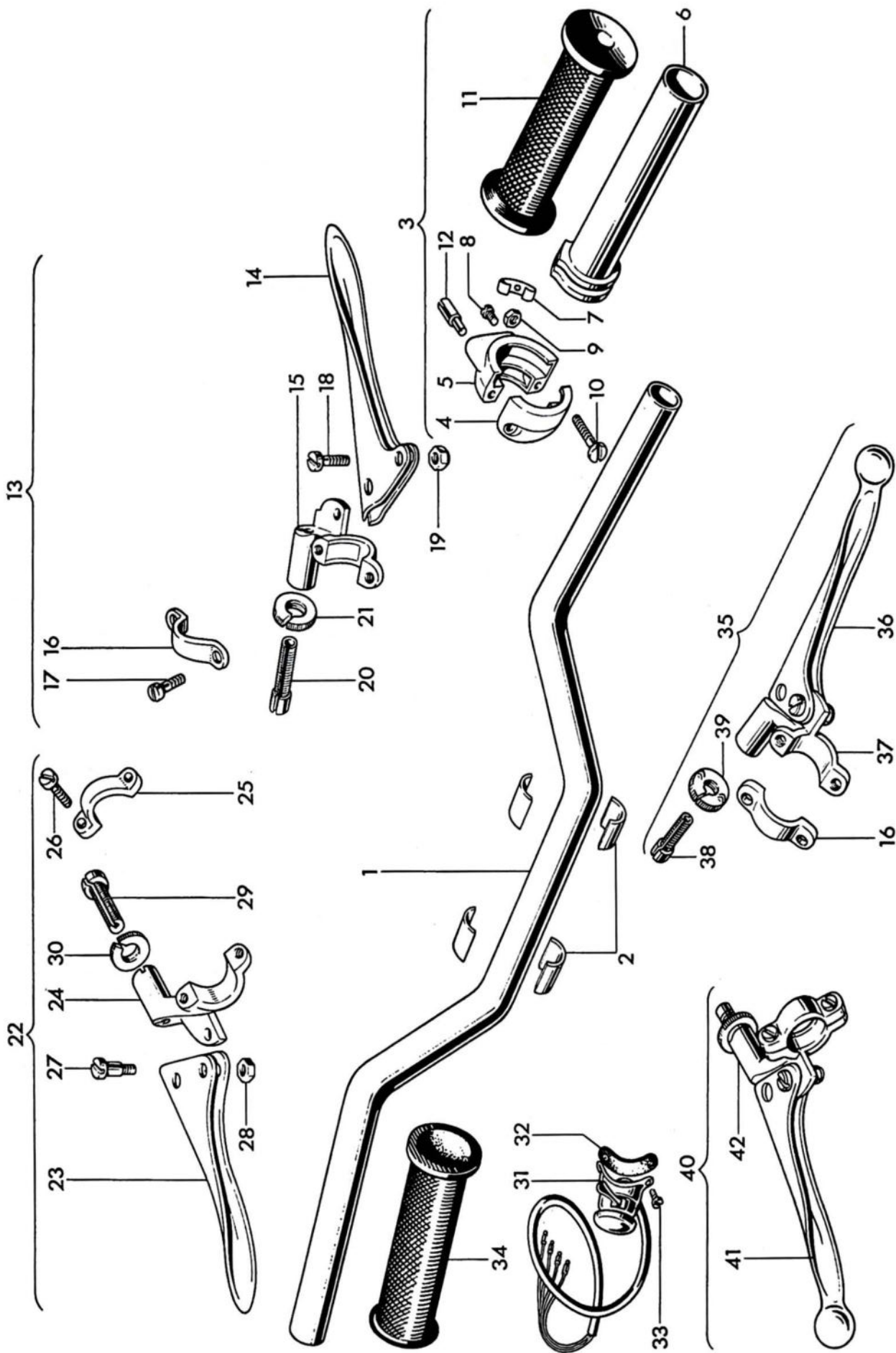

Fig. 25. HANDLEBARS AND CONTROL LEVERS

Ref. No.	Part No.	DESCRIPTION	3TA	5TA	T90	T100SS
HANDLEBARS AND CONTROL LEVERS						
1	H1871	Handlebar	1	1	-	-
1	H1872	Handlebar	-	-	1	1
1	H1869	American handlebar	1	1	-	-
1	H1873	American handlebar	-	-	1	1
2	H1425	Packing piece	4	4	4	4
3	16/417	TWISTGRIP	1	1	1	1
4	16/328	Body top half	1	1	1	1
5	16/329	Body bottom half	1	1	1	1
6	16/091	Rotor	1	1	1	1
7	16/008	Friction spring	1	1	1	1
8	16/009	Friction spring screw	1	1	1	1
9	16/010	Nut	1	1	1	1
10	11/014	Screw	2	2	2	2
11	16/070	Handlebar grip	1	1	1	1
12	16/011	Cable stop	1	1	1	1
13	18/999	FRONT BRAKE LEVER ASSEMBLY	1	1	1	1
14	18/535	Brake lever	1	1	1	1
15	18/1013	Brake lever bracket	1	1	1	1
16	12/595	Clamp	1	1	1	1
17	11/014	Screw	2	2	2	2
18	18/087	Fulcrum screw	1	1	1	1
19	18/053	Self-locking nut	1	1	1	1
20	18/1005	Cable adjuster	1	1	1	1
21	18/1006	Thumb nut	1	1	1	1
22	18/1000	CLUTCH LEVER ASSEMBLY	1	1	1	1
23	18/528	Clutch lever	1	1	1	1
24	18/1009	Clutch lever bracket	1	1	1	1
25	12/595	Clamp	1	1	1	1
26	11/014	Screw	2	2	2	2
27	18/087	Fulcrum screw	1	1	1	1
28	18/053	Self-locking nut	1	1	1	1
29	18/1005	Cable adjuster	1	1	1	1
30	18/1006	Thumb nut	1	1	1	1
31	31563	Horn push and dip switch	1	1	1	1
32	380459	Backing rubber	1	1	1	1
33	H1876	Screw (½ in. U.H.)	2	2	2	2
34	16/069	Handlebar grip	1	1	1	1
35	18/951	FRONT BRAKE LEVER ASSEMBLY (Ball-end)	A	A	A	A
36	18/754	Brake lever (Ball-end)	A	A	A	A
37	18/777	Brake lever bracket	A	A	A	A
38	18/838	Cable adjuster	A	A	A	A
39	18/839	Thumb nut	A	A	A	A
40	18/952	CLUTCH LEVER ASSEMBLY (Ball-end)	A	A	A	A
41	18/752	Clutch lever (Ball-end)	A	A	A	A
42	18/773	Clutch lever bracket	A	A	A	A

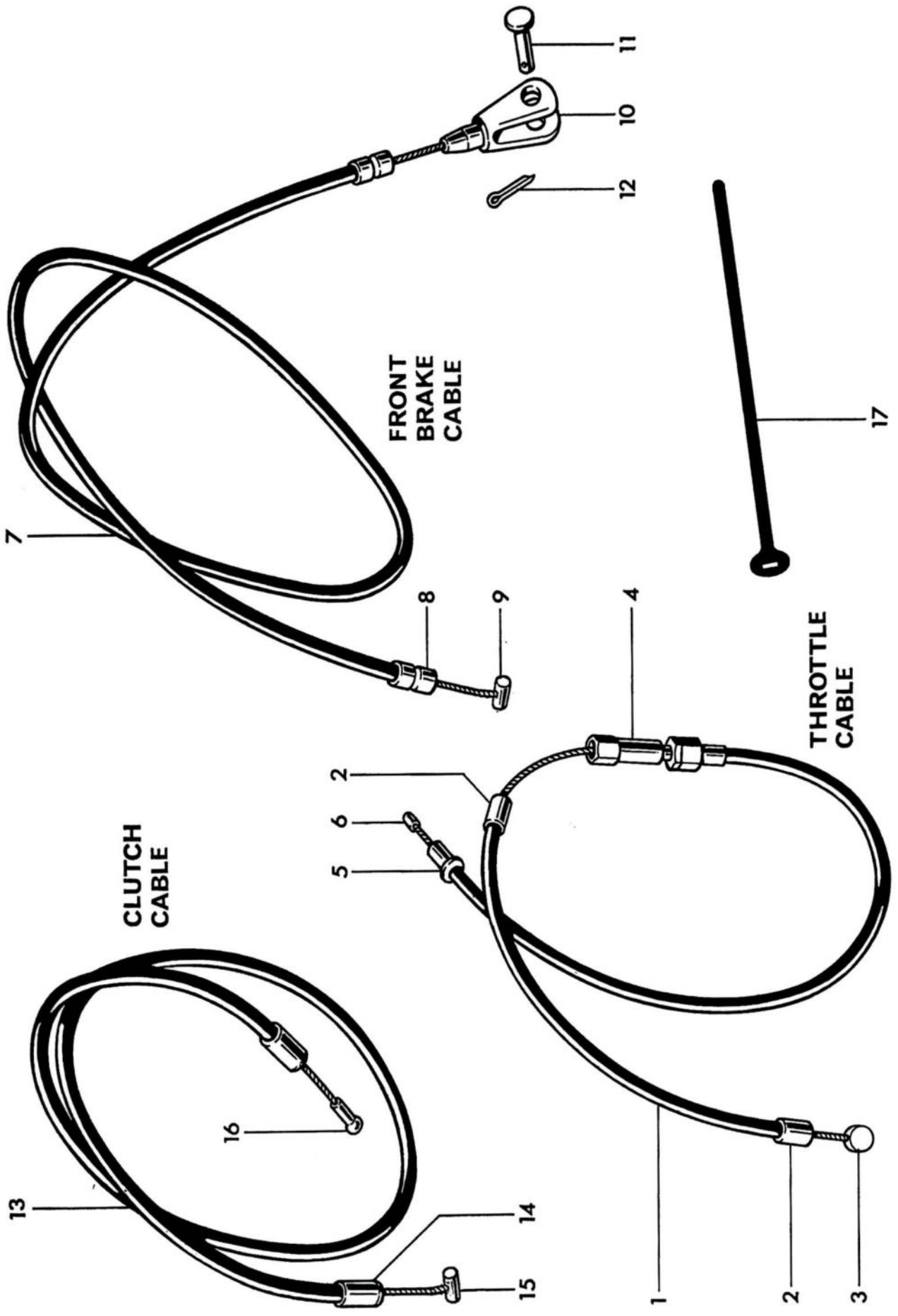

Fig. 26. CONTROL CABLES

Ref. No. Part. No. DESCRIPTION QUANTITY

CONTROL CABLES

									3TA	5TA	T90	T100SS
1	D531	THROTTLE CABLE	1	1	-	-
1	D495	THROTTLE CABLE	-	-	1	1
1	D532	AMERICAN THROTTLE CABLE	A	A	-	-
2	D101	Ferrule	3	3	3	3
3	D83	Nipple	1	1	1	1
4	D104	Adjuster	1	1	1	1
5	6/132A	Ferrule	1	1	1	1
6	NS191	Nipple	1	1	1	1
7	D561	FRONT BRAKE CABLE	1	1	-	-
7	D560	FRONT BRAKE CABLE	-	-	1	1
8	D103	Ferrule	2	2	2	2
9	D506	Nipple	1	1	1	1
10	W593	Fork end	1	1	1	1
11	WF32	Pivot pin...	1	1	1	1
12	$\frac{1}{16}$ in. x $\frac{3}{8}$ in.	Split pin	1	1	1	1
13	D566	CLUTCH CABLE	1	1	1	1
13	D565	AMERICAN CLUTCH CABLE	A	A	A	A
14	D103	Ferrule	2	2	2	2
15	D506	Nipple	1	1	1	1
16	DS73	Nipple	1	1	1	1
17	XA69	Cable clip			as required	

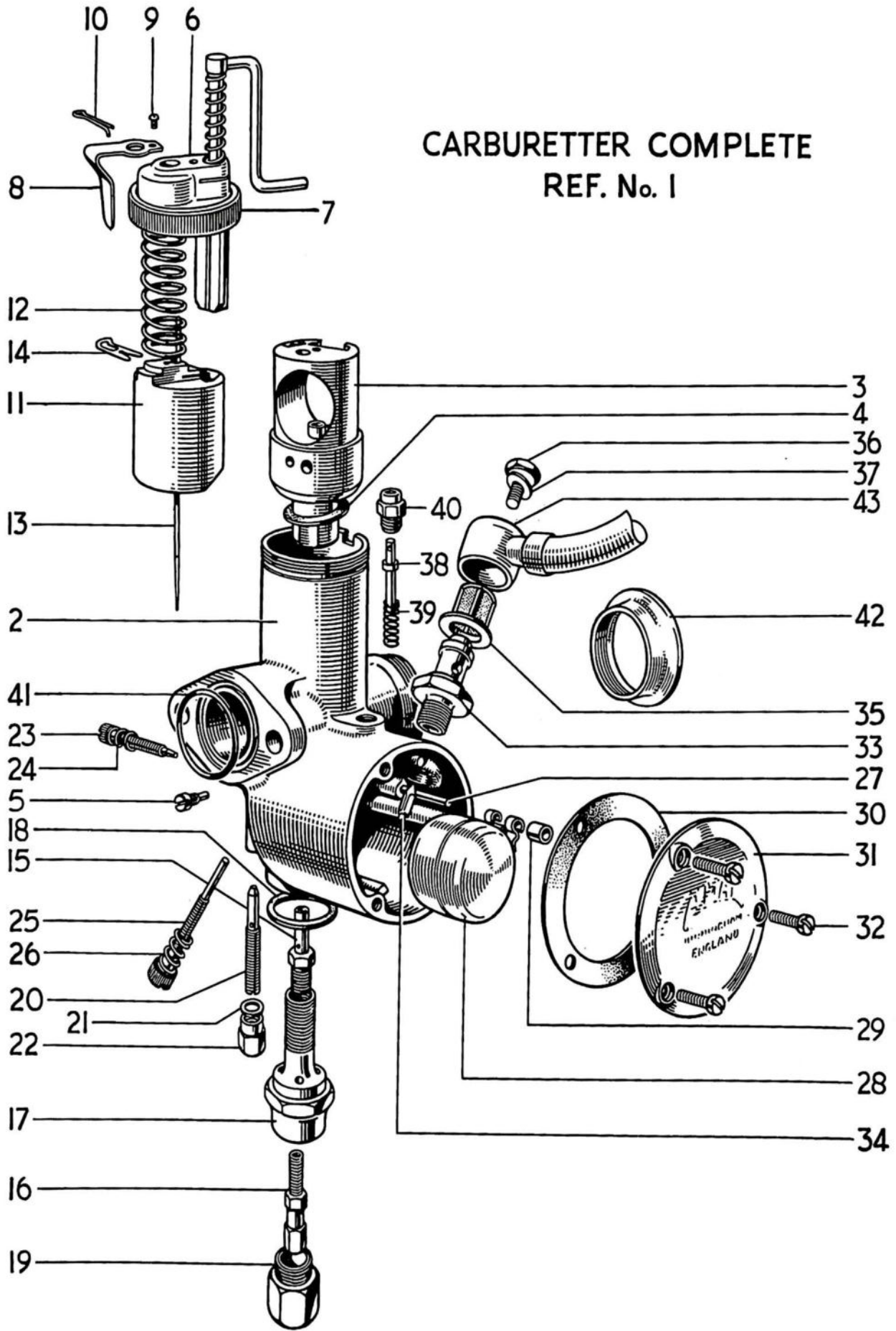

Fig. 27. CARBURETTER, 3TA AND 5TA

Ref. No.	Part No.	DESCRIPTION	3TA	5TA
CARBURETTER, 3TA AND 5TA				
1	375/62	CARBURETTER, 25/32 in. choke	1	-
1	375/35	CARBURETTER, 7/8 in. choke	-	1
2	375/003	Mixing chamber, 25/32 in. choke	1	-
2	375/005	Mixing chamber, 7/8 in. choke	-	1
3	375/057	Jet block, 25/32 in. choke	1	-
3	375/059	Jet block, 7/8 in. choke	-	1
4	375/067	Joint washer	1	1
5	376/070	Peg screw	1	1
6	375/102	AIR VALVE ASSEMBLY	1	1
7	375/065	Mixing chamber cap	1	1
8	375/071	Spring	1	1
9	4/241	Screw	1	1
10	30/064	Spring	1	1
11	375/060	Throttle valve (3½ cutaway)	1	-
11	375/060	Throttle valve (3 cutaway)	-	1
12	375/079	Throttle return spring	1	1
13	375/063	Needle (Type B)	1	1
14	4/230	Needle clip	1	1
15	376/072	Needle jet (.106)	1	1
16	376/100	Main jet (100)	1	-
16	376/100	Main jet (160)	-	1
17	376/073	Jet holder	1	1
18	376/074	Fibre washer	1	1
19	376/075	Cover nut	1	1
20	376/076	Pilot jet (25)	1	1
21	116/162	Fibre washer	1	1
22	376/095	Cover nut	1	1
23	332/017	Air adjusting screw	1	1
24	4/148	Spring	1	1
25	376/068	Throttle stop screw	1	1
26	376/069	Spring	1	1
27	376/085	Float spindle	1	1
28	376/083	Float	1	1
29	376/094	Bush	1	1
30	376/078	Joint washer	1	1
31	376/077	Cover	1	1
32	376/079	Screw	3	3
33	376/088	Needle seating	1	1
34	376/089	Needle	1	1
35	376/093	Filter	1	1
36	376/091	Bolt	1	1
37	376/092	Fibre washer	1	1
38	376/086	Tickler	1	1
39	376/087	Spring	1	1
40	343/011	Tickler body	1	1
41	244/765	"O" ring seal...	1	1
42	229/048	Air intake tube	A	A
43	F4308	Petrol pipe	1	1

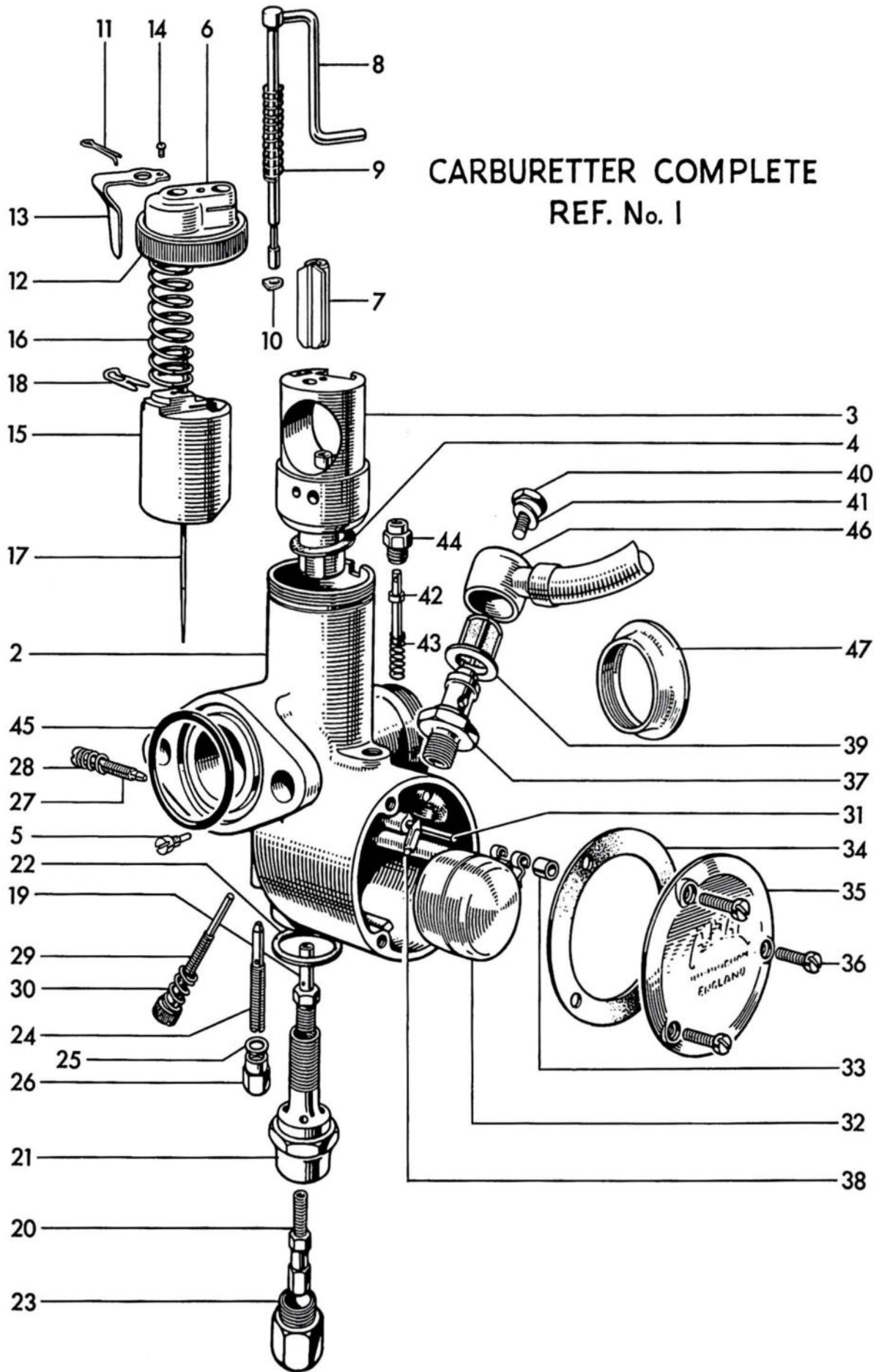

Fig. 28. CARBURETTER, T90 AND T100SS

CARBURETTER, T90 AND T100SS

									T90	T100SS
1	376/300	CARBURETTER, $\frac{1}{8}$ in. choke	1	-
1	376/273	CARBURETTER, 1 in. choke	-	1
2	376/001	Mixing chamber, $\frac{1}{8}$ in. choke	1	-
2	376/002	Mixing chamber, 1 in. choke	-	1
3	376/055	Jet block, $\frac{1}{8}$ in. choke	1	-
3	376/056	Jet block, 1 in. choke	-	1
4	376/067	Joint washer	1	1
5	376/070	Peg screw	1	1
6	376/158	Mixing chamber top	1	1
7	376/197	Air valve	1	1
8	376/402	Control rod and lever	1	1
9	376/109	Return spring	1	1
10	376/409	Friction washer	1	1
11	30/064	Click spring	1	1
12	376/065	Mixing chamber cap	1	1
13	29/308	Spring	1	1
14	4/241	Screw	1	1
15	376/060	Throttle valve (3 cutaway)	1	-
15	376/060	Throttle valve ($3\frac{1}{2}$ cutaway)	-	1
16	376/061	Throttle return spring	1	1
17	376/063	Needle (Type C)	1	1
18	4/230	Needle clip	1	1
19	376/072	Needle jet (.106)	1	1
20	376/100	Main jet (180)	1	-
20	376/100	Main jet (190)	-	1
21	376/073	Jet holder	1	1
22	376/074	Fibre washer	1	1
23	376/075	Cover nut	1	1
24	376/076	Pilot jet (20)	1	-
24	376/076	Pilot jet (25)	-	1
25	116/162	Fibre washer	1	1
26	376/095	Cover nut	1	1
27	332/017	Air adjusting screw	1	1
28	4/148	Spring	1	1
29	376/068	Throttle stop screw	1	1
30	376/069	Spring	1	1
31	376/085	Float spindle	1	1
32	376/083	Float	1	1
33	376/094	Bush	1	1
34	376/078	Joint washer	1	1
35	376/077	Cover	1	1
36	376/079	Screw	3	3
37	376/088	Needle seating	1	1
38	376/089	Needle	1	1
39	376/093	Filter	1	1
40	376/091	Bolt	1	1
41	376/092	Fibre washer	1	1
42	376/086	Tickler	1	1
43	376/087	Spring	1	1
44	343/011	Tickler body	1	1
45	244/1048	"O" ring seal...	1	1
46	F4308	Petrol pipe	1	1
47	376/066	Air intake tube	A	A

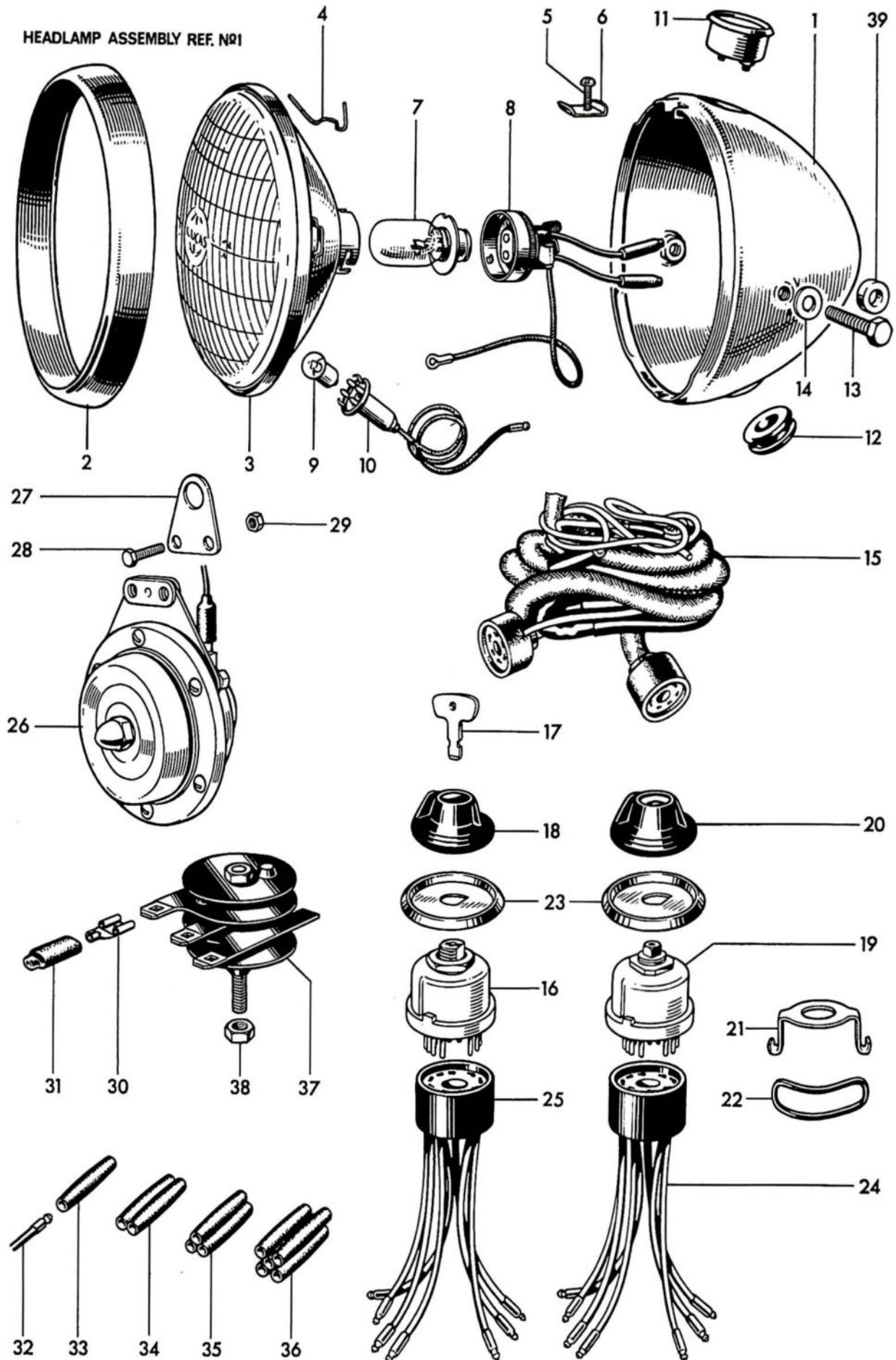

Fig. 29. T90 AND T100SS HEADLAMP, WIRING HARNESS AND SWITCHES

Ref. No.	Part No.	DESCRIPTION	QUANTITY	
			T90	T100SS
T90 AND T100SS HEADLAMP, WIRING HARNESS AND SWITCHES				
1	58934	HEADLAMP COMPLETE (TYPE SS700P)	1	1
2	553248	Rim	1	1
3	516798	Light unit	1	1
4	504665	Fixing wire	6	6
5	144921	Screw	1	1
6	534296	Plate	1	1
7	312	Bulb (30/24W Vert. dip pre-focus)	1	1
8	554602	Main bulbholder	1	1
9	988	Bulb (3W. M.C.C.)	1	1
10	554710	Pilot bulbholder	1	1
11	36296	Ammeter (Type 2AR)	1	1
12	862217	Grommet	1	1
13	112201	Bolt	2	2
14	137499	Plain washer	2	2
15	54936415	Wiring harness	1	1
16	34427	IGNITION SWITCH c/w KEY, type 88SA	1	1
17	54336176	Ignition key	1	1
18	54336178	Ignition switch cover	1	1
19	34289	Lighting switch, type 88SA	1	1
20	54330934	Knob c/w screw	1	1
21	F5983	Bracket	2	2
22	F5988	Rubber band	2	2
23	54330576	Switch bezel plate	2	2
24	54930007	Replacement harness socket (lighting)	1	1
25	54930008	Replacement harness socket (ignition)	1	1
26	70163	Horn (Type 8H)	1	1
27	F6632	Horn bracket	1	1
28	T1076	Bolt ($\frac{3}{8}$ in. U.H.)	2	2
29	F3799	Nut	2	2
30	54942078	Lucar connector	5	5
31	54190042	Insulating cover	5	5
32	900269	Snap connector terminal	A	A
33	900288	Single snap connector	A	A
34	850641	Double snap connector	A	A
35	850844	Triple snap connector	A	A
36	850832	Quintuple snap connector	A	A
37	49072	Rectifier, type 2DS506	1	1
38	F5338	Nut (156596)	1	1
39	H1932	Distance piece	2	2

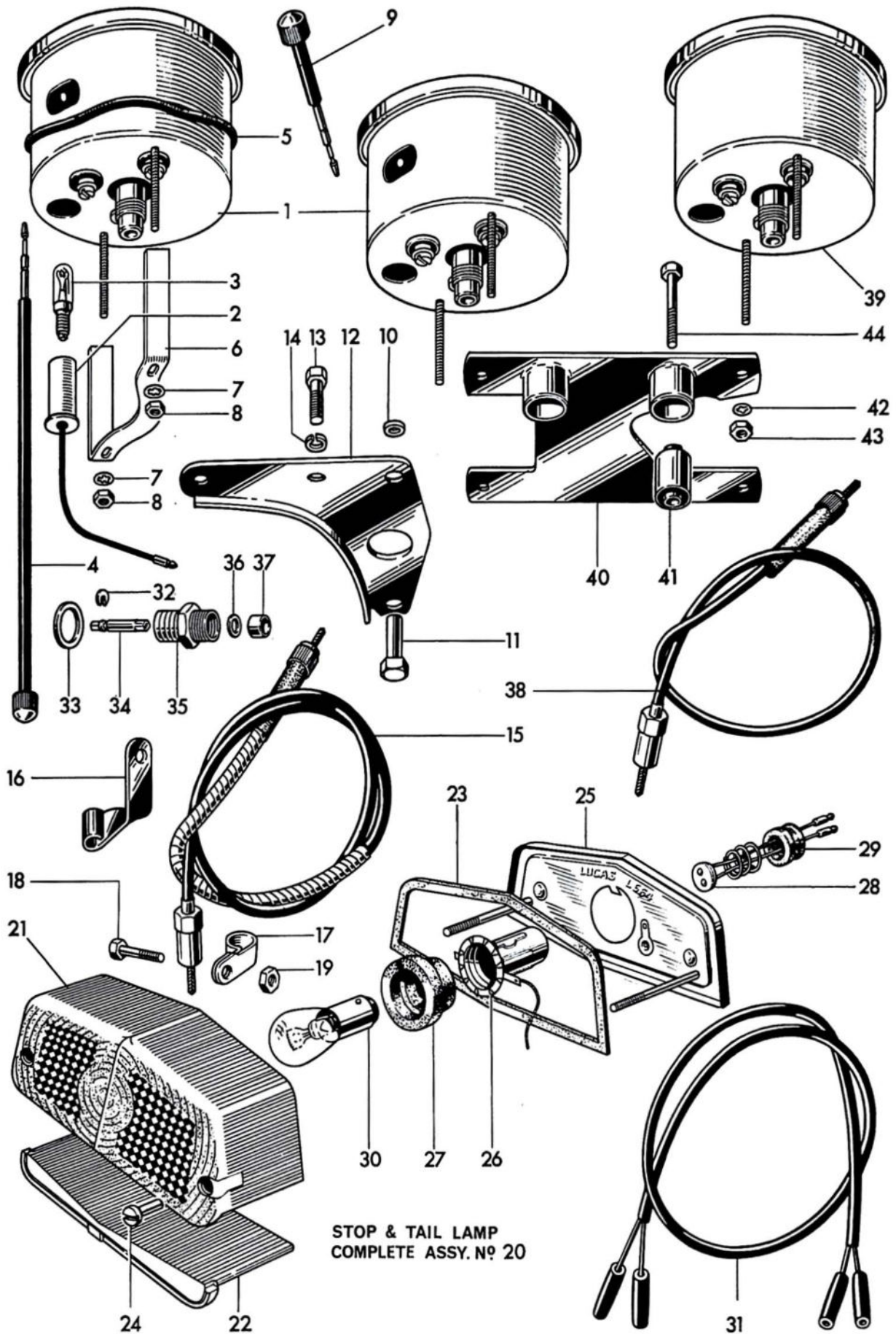

Fig. 30. SPEEDOMETER, TACHOMETER AND TAIL LAMP

Ref. No.	Part No.	DESCRIPTION	3TA	5TA	T90	T100SS
SPEEDOMETER, TACHOMETER AND TAIL LAMP						
1	SSM 5002/00	Speedometer, head, M.P.H.	1	1	-	-
1	SSM 5002/01	Speedometer head, K.P.H.	A	A	-	-
1	SSM 5001/00	Speedometer head, M.P.H.	-	-	1	1
1	SSM 5001/01	Speedometer head, K.P.H.	-	-	A	A
2	554734	Bulbholder	1	1	1	1
3	990	Bulb, 3W. M.E.S.	1	1	1	1
4	41-118-127-72	Trip control	1	1	-	-
5	31-753-778	Rubber ring	1	1	-	-
6	31-674-188-01	Fixing strap	1	1	-	-
7	30-283-014-11	Washer	2	2	-	-
8	30-277-023-11	Nut	2	2	-	-
9	41-148-203-10	Trip control	-	-	1	1
10	H1702	Distance piece	-	-	2	2
11	H1701	Sleeve nut	-	-	2	2
12	H1668	Bracket	-	-	1	1
13	DS57	Bolt ($\frac{7}{8}$ in. U.H.)	-	-	2	2
14	S26-2	Spring washer	-	-	2	2
15	D490	Speedometer cable (58 ins. long)	1	1	1	1
16	H1698	Cable bracket	1	1	-	-
17	F3098	Clip	1	1	1	1
18	F3468	Bolt ($2\frac{1}{8}$ in. U.H.)	-	-	1	1
19	S1-51	Nut	-	-	1	1
20	53432	STOP AND TAIL LAMP (Type 564)	1	1	1	1
21	573839	Lens...	1	1	1	1
22	575200	Window	1	1	1	1
23	575308	Lens seating gasket	1	1	1	1
24	575219	Sleeve nut	2	2	2	2
25	576002	Base assembly	1	1	1	1
26	575209	Bulbholder	1	1	1	1
27	575207	Grommet	1	1	1	1
28	573828	Contact assembly	1	1	1	1
29	573825	Grommet	1	1	1	1
30	384	Bulb (6/18W offset pin)	1	1	1	1
31	838604	Stop and tail lamp lead	1	1	1	1
32	D494	Circlip	-	-	1	1
33	T1257	Fibre washer	-	-	1	1
34	D493	Spade	-	-	1	1
35	E5731	ADAPTOR	-	-	1	1
36	E4803	"O" ring	-	-	1	1
37	E5733	Nylon bush	-	-	1	1
38	D529	Tachometer cable ($34\frac{1}{2}$ in. long)	-	-	1	1
39	RSM 3001/02	Tachometer	-	-	1	1
40	H1596	Mounting bracket	-	-	1	1
41	30-282-014-11	Washer	-	-	4	4
42	30-276-037-11	Nut	-	-	4	4
43	H1087	Metalastik bush	-	-	2	2
44	H1086	Bolt ($1\frac{1}{8}$ in. U.H.)	-	-	2	2