



REPLACEMENT PARTS CATALOGUE

FOR

1974 MODELS 30_{CU.IN.} (500_{C.C.})

TROPHY TRAIL TR5T
SERIES 1

PART NO. 99-2253

www.britcycle.com.au



REPLACEMENT PARTS CATALOGUE

FOR 1974

TROPHY TRAIL TR5T

TRIUMPH ENGINEERING COMPANY LIMITED
MERIDEN WORKS · ALLESLEY · COVENTRY CV5 9AU · ENGLAND
TELEPHONE COVENTRY (0203) 20221 **TELEGRAMS "TRUSTY" COVENTRY**
MERIDEN 331 **TELEX "TRUSTY" 31305**

PUBLISHED JUNE 1973

INTRODUCTION

The Triumph Engineering Co. Ltd. point out that the information in this catalog was complete and correct at the time of printing. Distributors will be informed of any subsequent alterations.

GUARANTEE

Please refer to your local dealer or distributor for the latest terms of guarantee.

EASTERN U.S.A. DISTRIBUTOR:

Triumph Motorcycle Corporation,
P.O. Box 6790,
Towson,
Baltimore 4,
Maryland 21204.

Telex—Tricor Balt. 87728
Telephone—301-252-1700

WESTERN U.S.A. DISTRIBUTOR:

Triumph Motorcycle Corporation,
P.O. Box 275,
East Huntington Drive,
Duarte,
California 91010.

Telex—Tricor Duarte 675469
Telephone—213-359-3221
213-681-0255

ENGINE AND FRAME NUMBERS

The engine number is located on the left side of the engine, immediately below the cylinder barrel to crankcase flange.

The frame number is located on the left side of the frame headlug, beneath the fork top lug and forward of the gasoline tank.

Both the engine and frame number should be quoted in full in any correspondence relating to the machine.

©
Copyright

All rights reserved. No part of this publication may be reproduced without permission.

INDEX

	<i>Page</i>		<i>Page</i>
AIR FILTER	15	HANDLEBARS	51
ALTERNATOR	7, 29	HANDLEBAR MOUNTINGS	53
AUTO-ADVANCE UNIT	21	HEADLAMP	59
		HORN	57
BATTERY CARRIER	35	KICKSTARTER	25
BRAKE SWITCH	31	MANIFOLD	15
BREATHER PIPES	37	MUFFLER	35
CAMSHAFT, INLET AND EXHAUST	7	OIL PUMP	11
CAPACITOR, IGNITION	57	OIL PIPES	37
CAPACITOR PACK	57	PISTONS	7
CARBURETOR	13	PROP STAND	39
CHAINS	29	PUSH RODS	17, 19
CHAINCASE	29	REAR WHEEL	47
CLUTCH	27	RECTIFIER	57
CLUTCH LEVER ASSEMBLY	51	REFLECTORS	55
COIL	57	ROCKERS	17, 19
CONNECTING RODS	7	SEAT	55
CONTACT BREAKER	21	SIDE PANEL	35
CONTROL CABLES	53	SPARK PLUG	57
CONTROL LEVERS	51	SPEEDOMETER	61
CRANKCASE	9	SPEEDOMETER GEARBOX	47
CRANKCASE UNDERSHIELD	31, 33	SUSPENSION UNITS	39
CRANKSHAFT	7	SWINGING ARM	39
CYLINDERS	17, 19	SWITCHES	51
CYLINDER HEAD	17, 19	TABLE OF STANDARD HARDWARE	64
ENGINE PLATES	31, 33	TACHOMETER	61
ENGINE TORQUE STAY	31, 33	TACHOMETER GEARBOX	61
EXHAUST PIPES	35	TAIL LAMP	59
EXHAUST PIPE ADAPTOR	35	TAPPETS	17, 19
FENDERS	49	TIMING GEARS	7
FLASHERS	59	TOOL KIT	63
FOOTRESTS	31, 33	VALVES	17, 19
FRAME	37	VALVE GUIDES	17, 19
FRONT FORKS	41	WIRING HARNESS	57
FRONT WHEEL	45	ZENER DIODE	57
GAS TANK	55		
GASKET SET	5		
GEARBOX	23		

HOW TO USE THIS PARTS CATALOG

First consult the Index on Page 3 for the parts or group of parts which you wish to locate. When you have located the parts make sure from the end columns that the part you have located does apply to your machine.

List the quantities required as single units; do not ask for "2 pairs" or "3 dozen".

In case of painted items always state the colour required. Painted parts are available only in the colours or alternatives specified for that model of that particular year.

COLOR

Gas Tank — Hi-Fire Vermilion/Gold
Fenders — Chromè
Side Panels — Black

N.B. It is important to state year and model of machine when ordering painted components.

PLEASE NOTE

THROUGHOUT THIS LIST, ASSEMBLIES ARE PRINTED IN CAPITALS AND THE COMPONENTS INCLUDED IN THAT ASSEMBLY ARE INDENTED IN THE DESCRIPTION COLUMN, REVERTING TO THE ORIGINAL ALIGNMENT WHEN THE ASSEMBLY IS COMPLETE. TO ORDER THE COMPLETE ASSEMBLY IT IS NECESSARY ONLY TO QUOTE THE ASSEMBLY NUMBER. ANY COMPONENT PARTS LISTED MAY ALSO BE OBTAINED SEPARATELY IF REQUIRED.

SPECIAL WORKSHOP TOOLS

A COMPLETE LIST OF WORKSHOP TOOLS CAN BE MADE AVAILABLE BY EITHER CONTACTING YOUR DEALER OR APPLYING DIRECT TO THE TRIUMPH SERVICE DEPARTMENT. IN MOST CASES THESE TOOLS ARE VERY COSTLY AS THEY ARE MADE ENTIRELY FOR WORKSHOP USE, AND THEREFORE, IT IS NOT RECOMMENDED THAT THE PRIVATE OWNER PURCHASES THE TOOLS IN ORDER TO AID SERVICING THE MACHINE ONCE OR TWICE ONLY. IN THESE CIRCUMSTANCES IT IS FAR MORE ECONOMICAL TO GET IN TOUCH WITH A RECOGNISED DEALER.

UNIFIED THREAD FORM

NEW PARTS HAVING THREADED FIXINGS INTRODUCED IN THIS CATALOGUE HAVE THE UNIFIED FORM OF SCREW THREADS. THIS CHANGEVER WILL BE CONTINUED AS AND WHEN NEW PARTS ARE INTRODUCED. EVEN WHERE PARTS ARE SIMILAR IN APPEARANCE NEW PART NUMBERS WILL BE ALLOCATED TO IDENTIFY THE UNIFIED THREADS. ALL NUTS, BOLTS AND STUDS HAVING THIS THREAD ARE IDENTIFIED BY MARKINGS. BOLTS HAVE A CIRCULAR RECESS IN THEIR HEADS, STUDS A CIRCULAR GROOVE ON THE END, AND NUTS HAVE INTERLOCKING CIRCLES ON THE SIDE.



TECHNICAL DATA

Bore and Stroke		2.716 x 2.578 ins. (70 x 67 m.m.)
Capacity		30 cu. ins. (500 c.c.)
Compression Ratio		9 : 1
Spark Plugs		Champion N4
Carburetor		Amal Concentric type R928
	Main Jet	.210
	Needle Jet	.106
	Needle	Standard
	Throttle Valve	No. 3
Gearbox Sprocket		18 teeth
Chains	Front	$\frac{3}{8}$ in. Duplex x 78 links
	Rear	$\frac{5}{8}$ in. x $\frac{3}{8}$ in. x 110 links
Capacities	Gas Tank	2 $\frac{1}{4}$ U.S. Galls.
	Oil Tank	6 U.S. pints
	Gearbox	$\frac{2}{3}$ pint (375 c.c.)
	Primary Chaincase (Initial fill)	$\frac{1}{4}$ pint (150 c.c.)
	Front Forks (each leg)	$\frac{1}{3}$ pint (200 c.c.)
Brakes	Front, diameter	8 in. (20.32 cm.)
	Rear, diameter	7 in. (17.18 cm.)
Tire Size	Front	3.00 x 21
	Rear	4.00 x 18
Gasket Sets	Decoke	99-3020
	Overhaul	99-3021

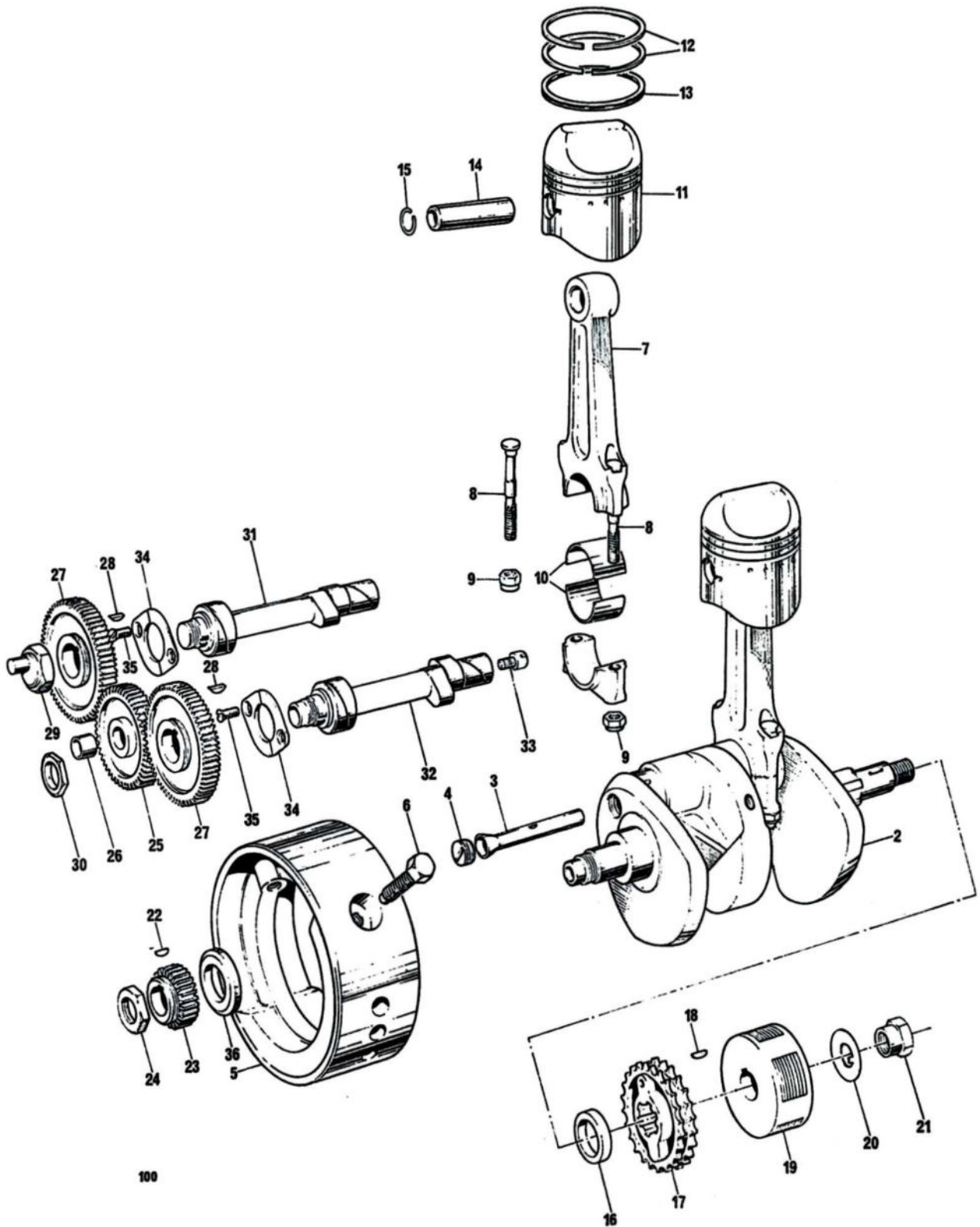

Fig 1. CRANKSHAFT AND CONNECTING RODS

Ref. No.	Part No.	DESCRIPTION	QUANTITY	REMARKS
CRANKSHAFT AND CONNECTING RODS				
1	70-9489	CRANKSHAFT AND FLYWHEEL ASSEMBLY	1	
2	70-9490	CRANKSHAFT	1	
3	70-3999	Oil tube	1	
4	70-9492	Screwed plug	1	
5	70-5870	Flywheel	1	
6	*21-1913	Flywheel bolt (1 $\frac{1}{2}$ in. U.H.)	3	
7	70-9915	CONNECTING ROD	2	
8	70-9914	Connecting rod bolt	2	
9	60-3761	Self-locking nut	2	
10	70-3706	Big end bearing (available in —.010 and —.020 undersizes	4	
11	70-6884	PISTON COMPLETE C.R.9:1	2	
12	70-6893	Taper compression ring	4	
13	70-6894	Oil control ring	2	
14	70-6861	Gudgeon pin	2	
15	70-6869	Circlip	4	
16	71-2664	Spacer	1	
17	70-3734	Engine Sprocket, 26T Duplex	1	
18	70-3851	Rotor key	1	
19	54213901	Rotor (99-0739)	1	
20	70-3975	Tab washer	1	
21	21-1915	Nut	1	
22	70-1580	Key	1	
23	70-1771	Timing pinion	1	
24	21-1914	Nut	1	
25	70-6160	INTERMEDIATE WHEEL	1	
26	70-0400	Bush	1	
27	71-2717	Camshaft pinion	2	
28	70-1558	Camshaft key	2	
29	71-1007	Inlet camshaft nut	1	
30	70-6523	Exhaust camshaft nut	1	
31	71-1064	Inlet camshaft	1	
32	70-9983	EXHAUST CAMSHAFT	1	
33	70-9988	Tachometer drive plug	1	
34	70-9502	Retaining plate	2	
35	21-1879	Screw ($\frac{1}{2}$ in. U.H.)	4	
36	70-9503	Clamping washer	1	
Not illus.	70-8038	Shim (0.010")	As required	} up to 4
Not illus.	71-2660	Shim (0.030")	As required	

* Use 60-0524 Loctite sealant.

ALTERNATIVE FITMENTS (NOT U.S.A.)

70-7603	Piston complete C.R. 7.5:1	2
---------	-----------------------------------	---

Ref. No.	Part No.	DESCRIPTION	QUANTITY	REMARKS
CRANKCASE				
1	71-1268	CRANKCASE DRIVE SIDE	1	
2	70-4147	Pivot pin	1	
3	70-3823	Camshaft bush	1	
4	70-3823	Camshaft bush	1	
5	71-1269	CRANKCASE TIMING SIDE	1	
6	70-9496	Oil scavenge pipe	1	
7	70-1509	Clip	1	
8	21-1920	Screw	1	
9	14-6102	Bolt	1	
10	70-7430	Tab washer	1	
11	57-1606	Needle roller bearing	1	
12	70-6386	Dowel at junction block	1	Ref. only
13	70-0375	Idler gear spindle	1	
14	57-0912	Peg (at thrust washer)	1	
15	70-3716	Hollow dowel	2	
16	14-0302	Nut	1	
17	14-0225	Bolt, Crankcase halves	1	
17	14-0224	Bolt, crankcase halves	1	
18	60-4247	Plain washer	5	
19	14-1302	Nut	2	
20	21-1925	Stud (3 $\frac{3}{8}$ in. U.H.)	2	
21	21-1919	Bolt	1	
22	21-1852	Nut	1	
23	21-1864	Oil pump stud (1 $\frac{5}{16}$ in. O.A.)	2	
24	70-9494	Right main bearing (ball journal)	1	
25	21-1921	Cylinder base stud (1 $\frac{1}{2}$ in. O.A.)	6	
26	21-1922	Cylinder base stud (1 $\frac{1}{16}$ in. O.A.)	2	
27	70-8751	Dowel	2	
28	70-9493	Left main bearing (roller journal)	1	
29	70-3724	Filter spring	1	
30	70-3722	Filter	1	
31	70-9501	Filter cap	1	
32	70-1577	Joint washer	2	
33	70-3723	Sealing washer	1	
34	21-1927	Stud (3 $\frac{1}{16}$ in. O.A.)	2	
35	21-1872	Drain plug	1	
36	57-1257	Joint washer	1	
37	70-8896	Fibre washer	1	
38	57-2166	Filler plug	1	
39	70-8782	Joint washer	1	
40	70-7431	"O" ring	1	
41	21-1872	Plug	1	
42	71-1079	Cover plate	1	
43	71-4044	Outlet stub-breather	1	
44	71-1460	Joint washer	1	
45	71-1077	Screw	2	
46	71-1075	Screw	1	
47	83-5290	Tee piece	1	
48	83-5292	Pipe, breather to tee piece	1	
49	60-2252	Clip, front	2	
Not illus.	70-4707	Grommet, alternator leads	1	
50	83-4813	Crankcase breather pipe-rear	1	
51	83-1615	Clip, rear	1	
52	60-2252	Clip, pipe to tee piece	1	

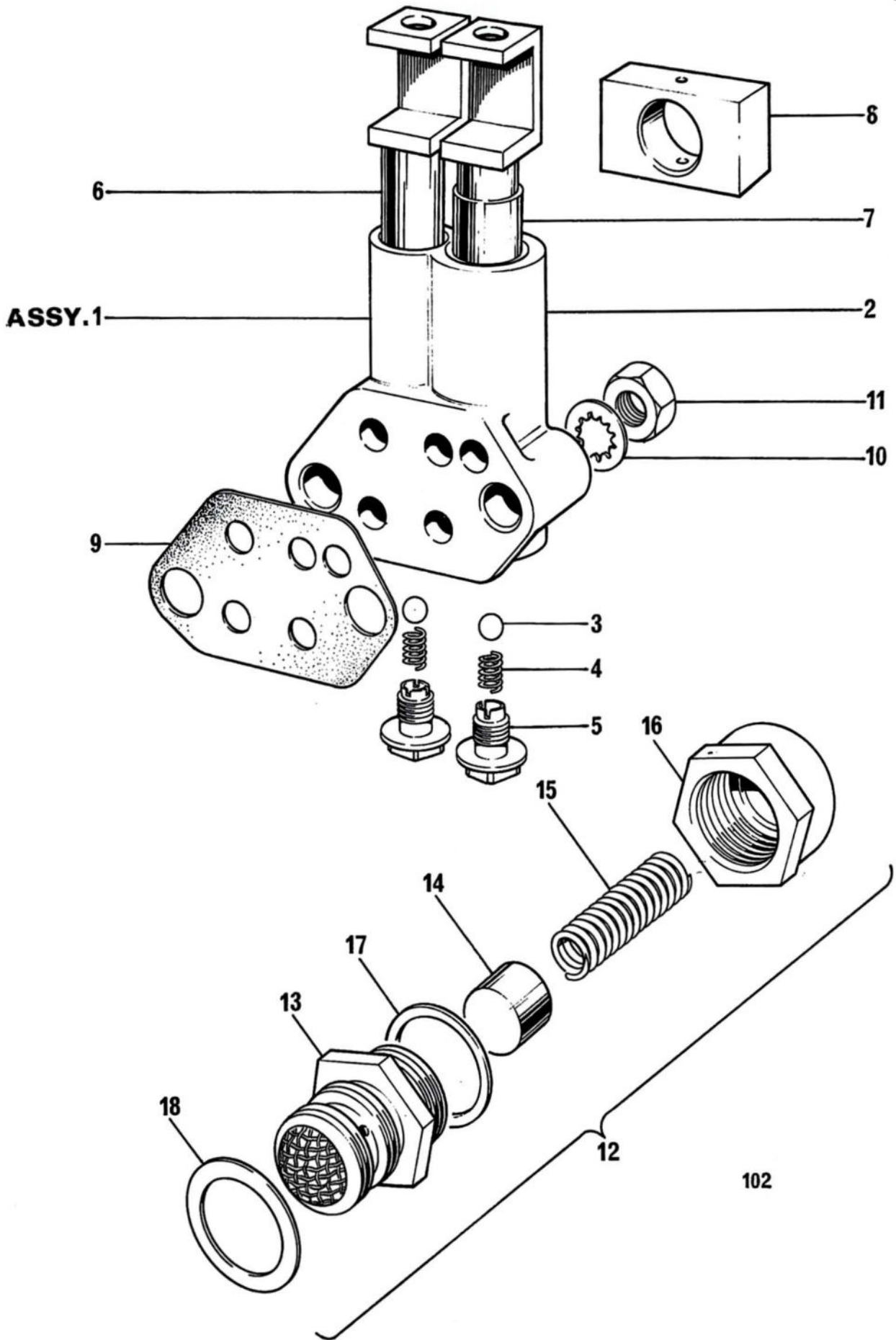

Fig. 3. OIL PUMP AND RELEASE VALVE

Ref. No. Part No. DESCRIPTION QUANTITY

OIL PUMP AND RELEASE VALVE

1	70-6928	OIL PUMP	1	
2	70-6680	Pump body... ..	Reference only	
3	60-2363	Valve ball	2	
4	70-0403	Valve spring	2	
5	70-2360	Screwed plug	2	
6	71-3422	Feed plunger	1	
7	70-6681	Scavenge plunger	1	
8	70-0495	Drive block	1	
9	71-1461	Joint washer	1	
10	70-3887	Serrated washer	2	
11	21-1906	Nut	2	
12	71-3447	OIL PRESSURE RELEASE VALVE	1	
13	70-7590	Body	Reference only	
14	70-8752	Piston	1	
15	70-7591	Spring	1	
16	70-6596	Cap	1	
17	70-8754	Joint washer (cap to body)	1	
18	70-1670	Joint washer	1	

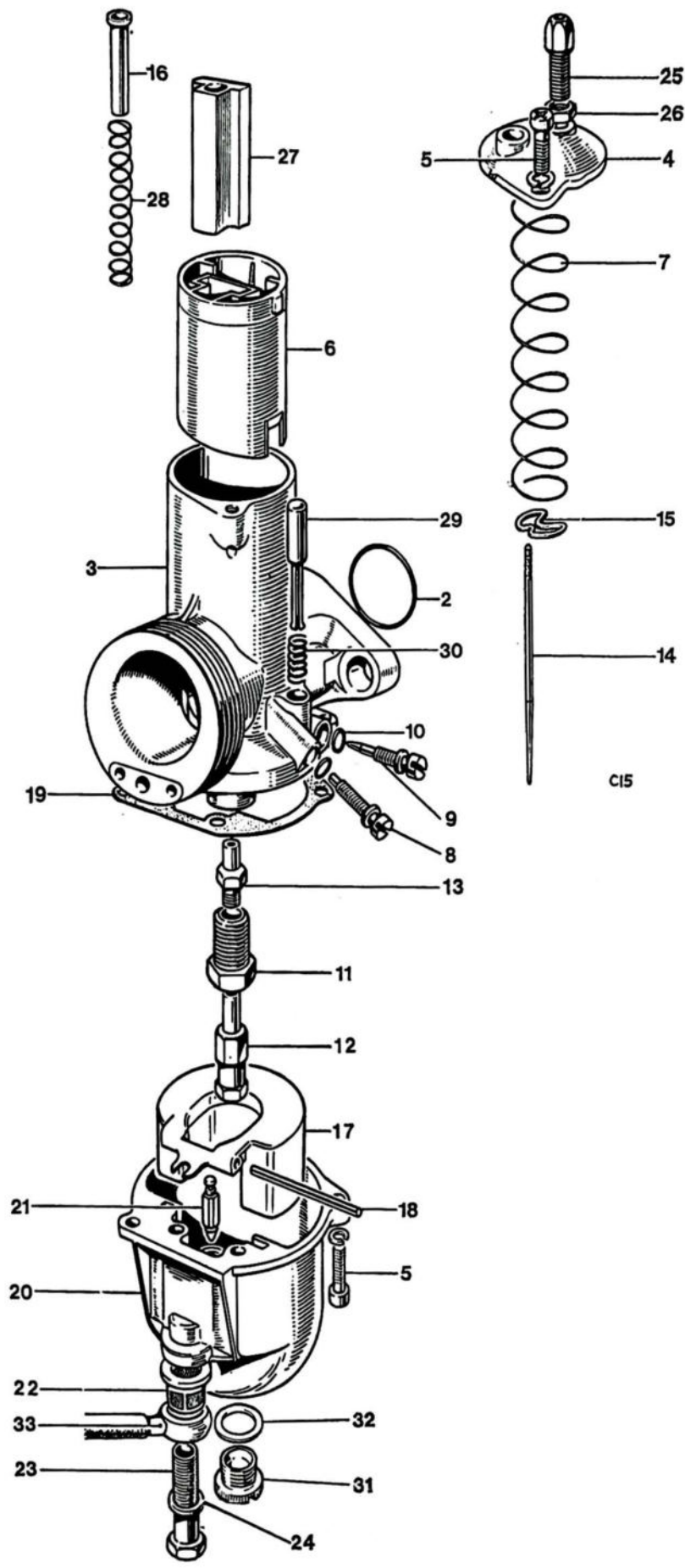

Fig. 4. CARBURETOR

Ref. No.	Part No.	DESCRIPTION	QUANTITY	REMARKS
CARBURETOR				
1	60-4189	CARBURETOR R928/21	1	
2	622/101	"O" ring seal (99-0522)	1	
3	R626/005	Mixing chamber R626/005	Reference only	
4	622/097	Mixing chamber top (99-1049)	4	
5	622/086	Screw (99-0521)	1	
6	622/060	Throttle valve (3 cutaway) (99-1125)	1	
7	622/065	Throttle return spring (copper plated) (99-0509)	1	
8	622/077	Throttle stop screw (99-0516)	1	
9	622/076	Air adjusting screw (99-0515)	2	
10	622/082	"O" ring (99-0520)	1	
11	622/128	Jet holder (99-1034)	1	
12	376/100	Main jet (99-0448) size 210	1	
13	622/122	Needle jet (99-1035) size .106	1	
14	622/124	Needle (99-1036)	1	
15	622/067	Needle clip (99-0510)	1	
16	622/134	Air valve guide sleeve (99-1051)	1	
17	622/069	Float (99-0512)	1	
18	622/071	Float spindle (99-0513)	1	
19	622/073	Joint washer (99-0514)	1	
20	622/055	Float chamber (99-1154)	1	
21	622/068	Float needle (99-0511)	1	
22	376/093	Filter (99-0438)	1	
23	622/078	Banjo bolt (99-0517)	1	
24	13/163	Fibre washer (99-1124)	1	
25	4/035	Cable adjuster	Reference only	
26	5/077	Nut (99-0224)	1	
27	622/062	Air slide	Reference only	
28	622/129	Air slide spring (99-1038)	1	
29	622/089	Tickler pin	Reference only	
30	14/032	Spring	Reference only	
31	622/147	Drain plug (99-1152)	1	
32	622/151	Washer (99-1153)	1	
33	83-4203	Petrol pipe	1	

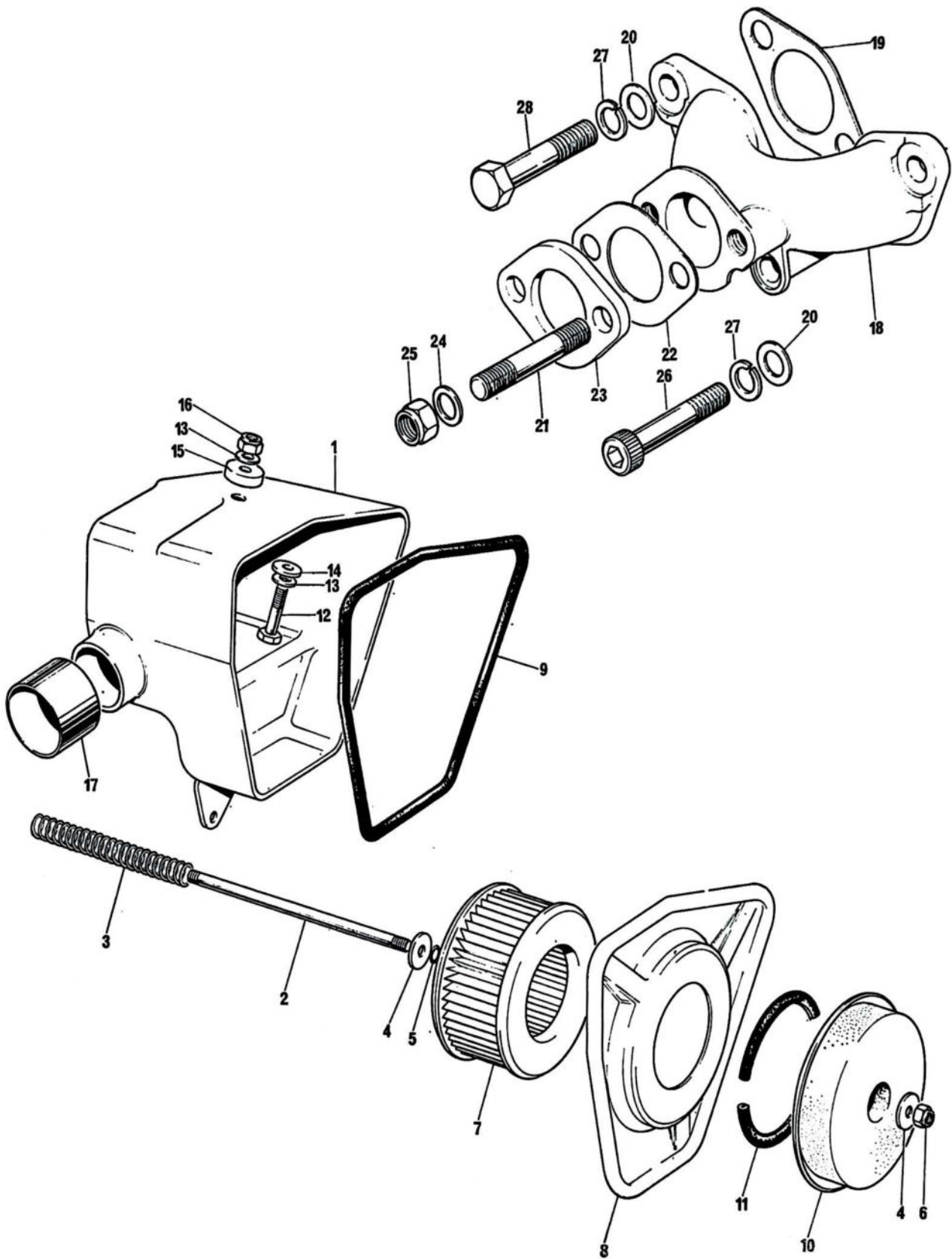

Fig. 5. AIR CLEANER AND MANIFOLD

Ref. No. Part No. DESCRIPTION QUANTITY

AIR CLEANER AND MANIFOLD

1	83-5162	Air filter box	1	
2	21-2222	Stud	1	
3	57-1877	Spring	2	
4	82-6310	Washer	2	
5	70-4803	'O' ring	1	
6	14-1301	Nut	1	
7	60-4274	Element	1	
8	83-5163	Cover, air box	1	
9	83-5177	Sealing strip	1	
10	83-5199	Air intake	1	
11	83-5200	Sealing strip	2	
12	14-0203	Bolt	1	
13	60-2347	Washer	1	
14	82-6968	Rubber washer	}	Air box - top fixing	1	
15	82-5228	Rubber washer			1
16	14-1301	Nut			1
17	83-5179	Connector, air box to carburettor	1	
18	71-3530	Inlet manifold	1	
19	70-6772	Joint washer	2	
20	60-4247	Plain washer	4	
21	21-0582	Stud (1 5/16 in. O.A.)	2	
22	71-3573	Joint washer	1	
23	70-4918	Insulating block	1	
24	60-4247	Plain washer	2	
25	14-1302	Self-locking nut	2	
26	14-7024	Socket head screw (2 in. U.H.)	2	
27	21-0648	Spring washer	4	
28	14-6115	Bolt	2	

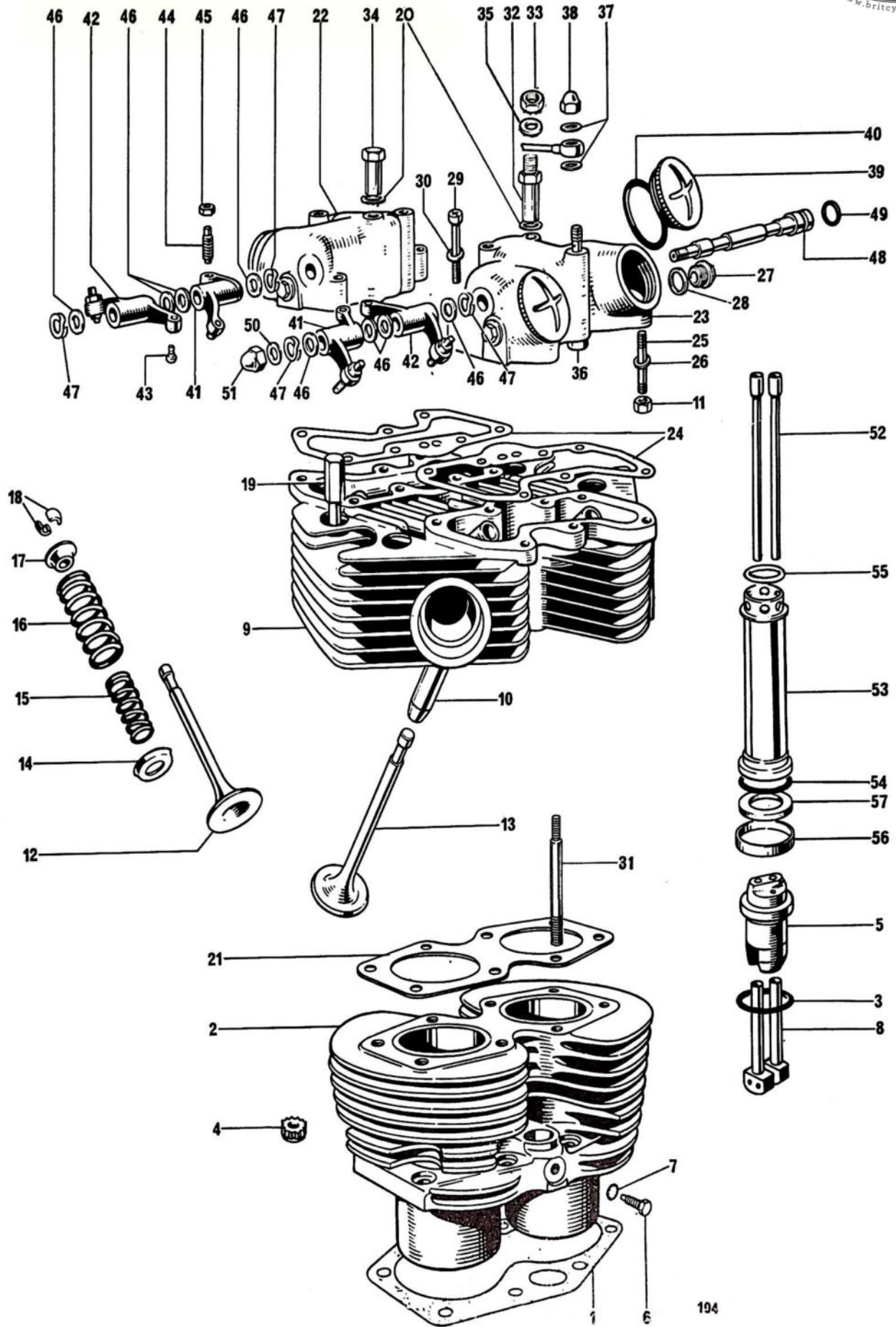

Fig. 6. CYLINDER BLOCK AND HEAD

Ref. No. Part No. DESCRIPTION QUANTITY

CYLINDER BLOCK AND HEAD

1	70-3798	Cylinder base gasket	1
2	70-9719	Cylinder block	1
3	70-7563	"O" ring	2
4	21-0692	Nut (12 point)	8
5	70-9352	Tappet guide block	2
6	97-0200	Tappet block screw ($\frac{7}{16}$ in. U.H.)	2
7	70-1612	Serrated washer	2
8	70-3753	Tappet	4
9	71-2644	CYLINDER HEAD c/w GUIDES	1
10	71-0229	Valve guide (cast iron)	4
11	14-0301	Nut (line 25)	4
12	70-6853	Inlet valve	2
13	70-6854	Exhaust valve	2
14	70-6855	Bottom Cup	4
15	70-5946	Inner valve spring	4
16	70-4011	Outer valve spring	4
17	70-3742	Top collar	4
18	99-0062	Split cotter	8
19	70-4456	Cylinder head bolt (2 25/32 in. U.H.)	4
20	82-2184	Plain washer	4
21	70-4675	Cylinder head gasket	1
22	71-3566	Inlet rocker box	1
23	71-3567	Exhaust rocker box	1
24	70-9511	Joint washer	2
25	14-1401	Rocker box stud	4
26	70-3302	Washer	4
27	71-2079	Plug, rocker box	4
28	57-2697	Joint washer	4
29	14-6609	Screw ($\frac{1}{8}$ in. U.H.)	4
30	70-3857	Plain washer	4
31	71-3643	Cylinder head stud	4
32	71-3645	Cylinder head torque stay nut	2
33	14-0303	Nut, torque stay	2
34	71-3644	Nut, cylinder head	2
35	60-2323	Washer	4
36	82-3809	Oil feed bolt	2
37	82-1880	Copper washer	6
38	97-0400	Domed nut	2
39	70-4610	Inspection cap	4
40	70-8782	"O" ring	4
41	70-3749	ROCKER (right exhaust, left inlet)	2
42	70-3750	ROCKER (left exhaust, right inlet)	2
43	70-7651	Rocker ball pin	4
44	70-3223	Rocker adjusting pin	4
45	60-4264	Adjuster lock nut	4
46	70-2534	Thrust washer, $\frac{7}{16}$ in.	6
46	70-1330	Thrust washer, $\frac{3}{8}$ in.	2
47	70-3224	Spring washer	4
48	71-3301	Rocker spindle	2
49	60-3548	Sealing rubber	2
50	70-1335	Copper washer	2
51	21-0550	Domed nut	2
52	70-4008	Push rod	4
53	71-2576	Cover tube	2

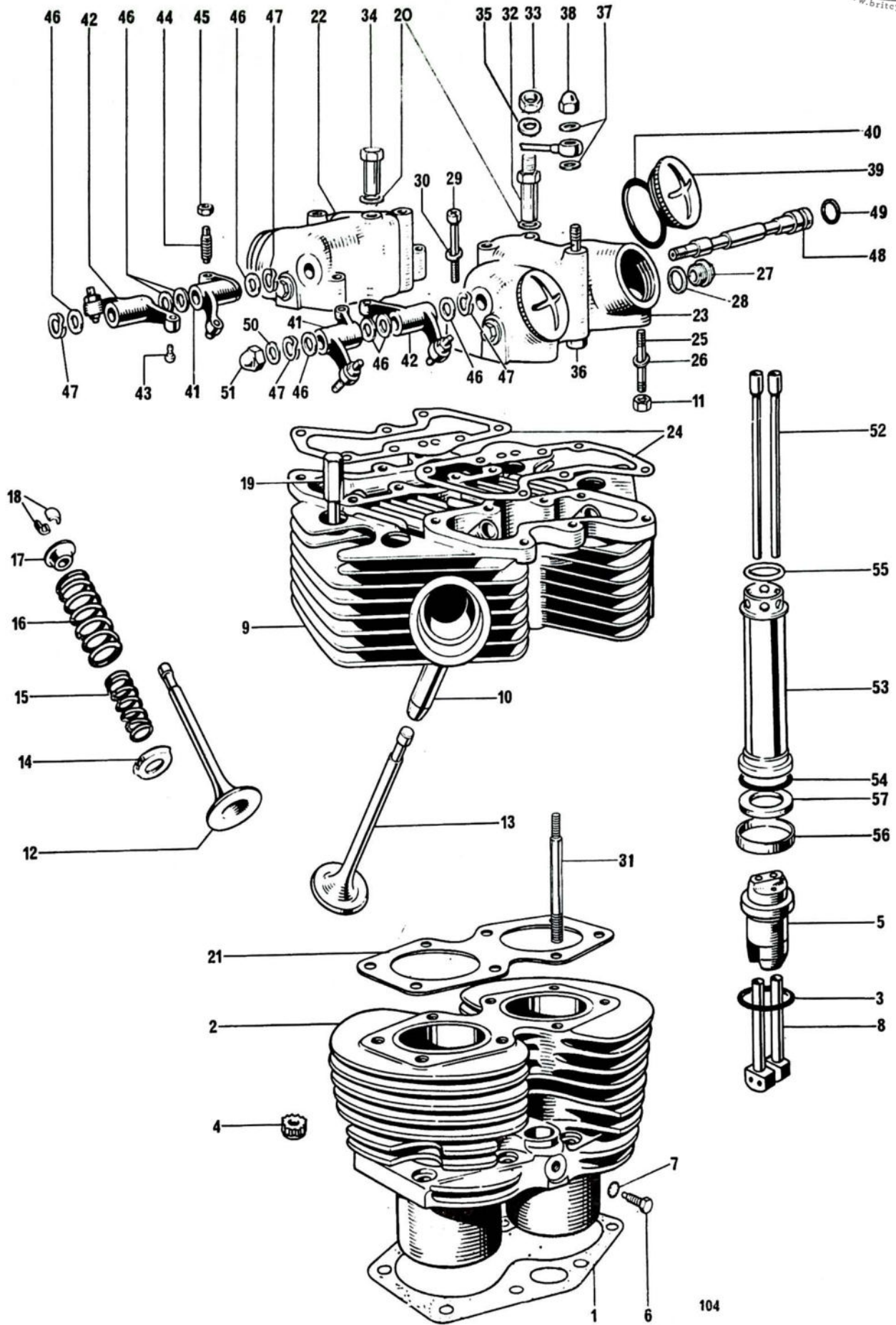
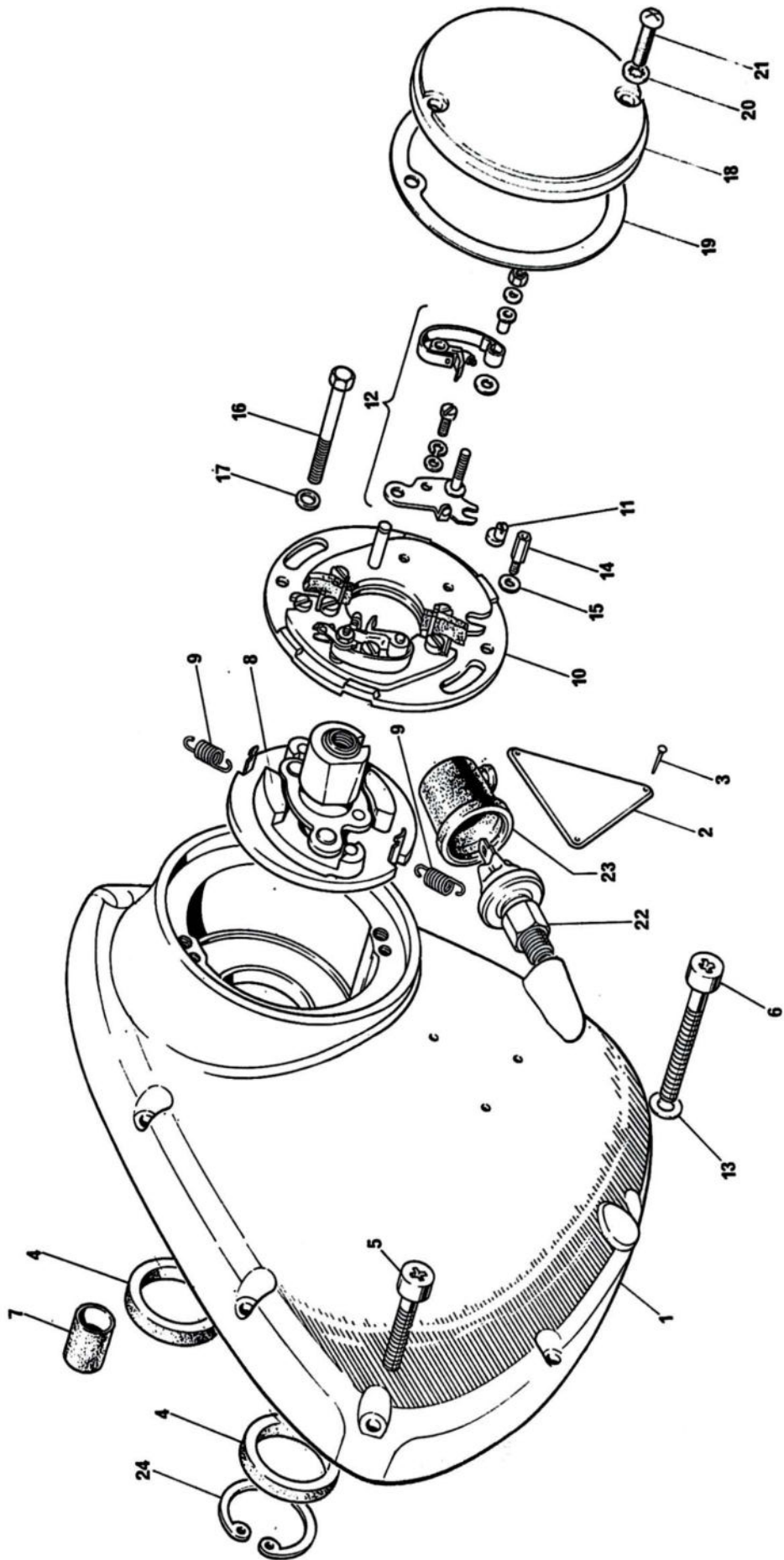

Fig. 6. CYLINDER BLOCK AND HEAD

Ref. No.	Part No.	DESCRIPTION	QUANTITY	REMARKS
----------	----------	-------------	----------	---------

CYLINDER BLOCK AND HEAD (continued)

54	70-7310	"O" ring, push rod cover tube (bottom)	2	
55	71-1283	"O" ring, push rod cover tube (top)	2	
56	71-1707	Sleeve, push rod cover tube	2	
57	70-3547	Joint washer, push rod cover tube	2	



105

Fig. 7. TIMING COVER AND CONTACT BREAKER

Ref. No.	Part No.	DESCRIPTION	QUANTITY	REMARKS
----------	----------	-------------	----------	---------

TIMING COVER AND CONTACT BREAKER

1	70-9250	Timing cover	1	
2	70-4016	Patent plate	1	
3	60-4255	Hammer-drive screw	3	
4	70-4568	Oil seal	2	
5	14-6607	Screw (7/8 in. U.H.)	4	
6	21-1916	Screw (1 1/8 in. U.H.)	4	
7	57-0989	Hollow dowel	1	
8	54419340	AUTO-ADVANCE UNIT (99-0771)	1	
9	54415642	Spring set (99-0757)	2	
10	54419097	CONTACT BREAKER PLATE ASSEMBLY (99-0768)	1	
11	54419220	Pin adjustment (99-0769)	2	
12	54419827	Contact set (99-0772)	2	
13	60-3963	Washer (cover screws)	8	
14	70-7680	Pillar bolt	2	
15	70-6559	Washer	2	
16	14-0208	Bolt	1	
17	70-8163	Washer	1	
18	70-8737	Cover	1	
19	71-1462	Joint washer	1	
20	60-4256	Serrated washer	2	
21	70-7354	Screw	2	
22	60-3719	Oil pressure switch	1	
23	71-2930	Cover pressure switch... ..	1	
24	70-4569	Circlip	1	
Not illus.	70-4849	Dowel pin, auto advance to camshaft	1	
Not illus.	60-2138	Timing label for C.B. cover	1	
Not illus.	70-9526	Blanking plug (to replace oil pressure switch)	Available	

Ref. No.	Part No.	DESCRIPTION	QUANTITY	REMARKS
GEARBOX SHAFTS, BEARINGS AND INNER COVER				
1	57-0665	High gear bearing (ball journal)	1	
2	57-1478	Oil seal	1	
3	37-0680	Circlip	1	
4	14-6608	Screw	2	
5	57-1422	Return spring plate	1	
6	57-0912	Peg	1	
7	57-1606	Layshaft bearing	1	
8	57-1607	Thrust washer	1	
9	57-3991	MAINSHAFT HIGH GEAR (22T)	1	
10	57-1405	High gear bush	1	
11	57-4040	MAINSHAFT c/w THIRD AND LOW GEARS (15/24T)	1	
12	57-1391	Clutch rod bush	1	
13	57-4031	Mainshaft second gear (20T)	1	
14	57-1411	Mainshaft distance piece	1	
15	57-4608	Layshaft c/w second and high gears (15/24T)	1	
16	57-3997	Layshaft third gear (20T)	1	
17	57-4033	LAYSHAFT LOW GEAR (29T)	1	
18	57-1393	Low gear bush	1	
19	57-1426	Pawl retaining disc	1	
20	57-3660	Camplate index plunger	1	
21	57-3661	Index plunger spring	1	
22	57-1457	Selector fork spindle	1	
23	57-1480	Mainshaft selector fork	1	
24	57-1481	Layshaft selector fork	1	
25	57-4218	Gear selector camplate	1	
26	57-1418	Camplate spindle	1	
27	—	Split pin ($\frac{1}{8}$ in. x $\frac{3}{4}$ in.)		References only
28	57-1416	Gear indicator pointer	1	
29	97-0688	Screw ($\frac{5}{16}$ in. U.H.)	1	
30	57-4614	Inner cover	1	
31	57-1417	Gear indicator plate	1	
32	60-4255	Indicator plate rivet	2	
33	57-1440	Hollow dowel	2	
34	57-1157	Kickstarter stop plate	1	
35	57-1390	Stop plate anchor screw	1	
36	57-1981	KICKSTARTER SPINDLE	1	
37	57-1431	Kickstarter pawl	1	
38	57-1282	Plunger	1	
39	57-1161	Plunger spring	1	
40	57-1897	Needle roller bearing	1	
41	57-1469	Mainshaft bearing (Ball journal)—metric	1	
42	57-4113	Circlip	1	
43	57-2240	Tab washer	1	
44	21-0594	Mainshaft nut	1	
45	57-1464	Distance piece	1	
46	57-1441	Kickstarter return spring	1	
47	70-4803	"O" ring	1	
48	57-4612	Dipstick	1	

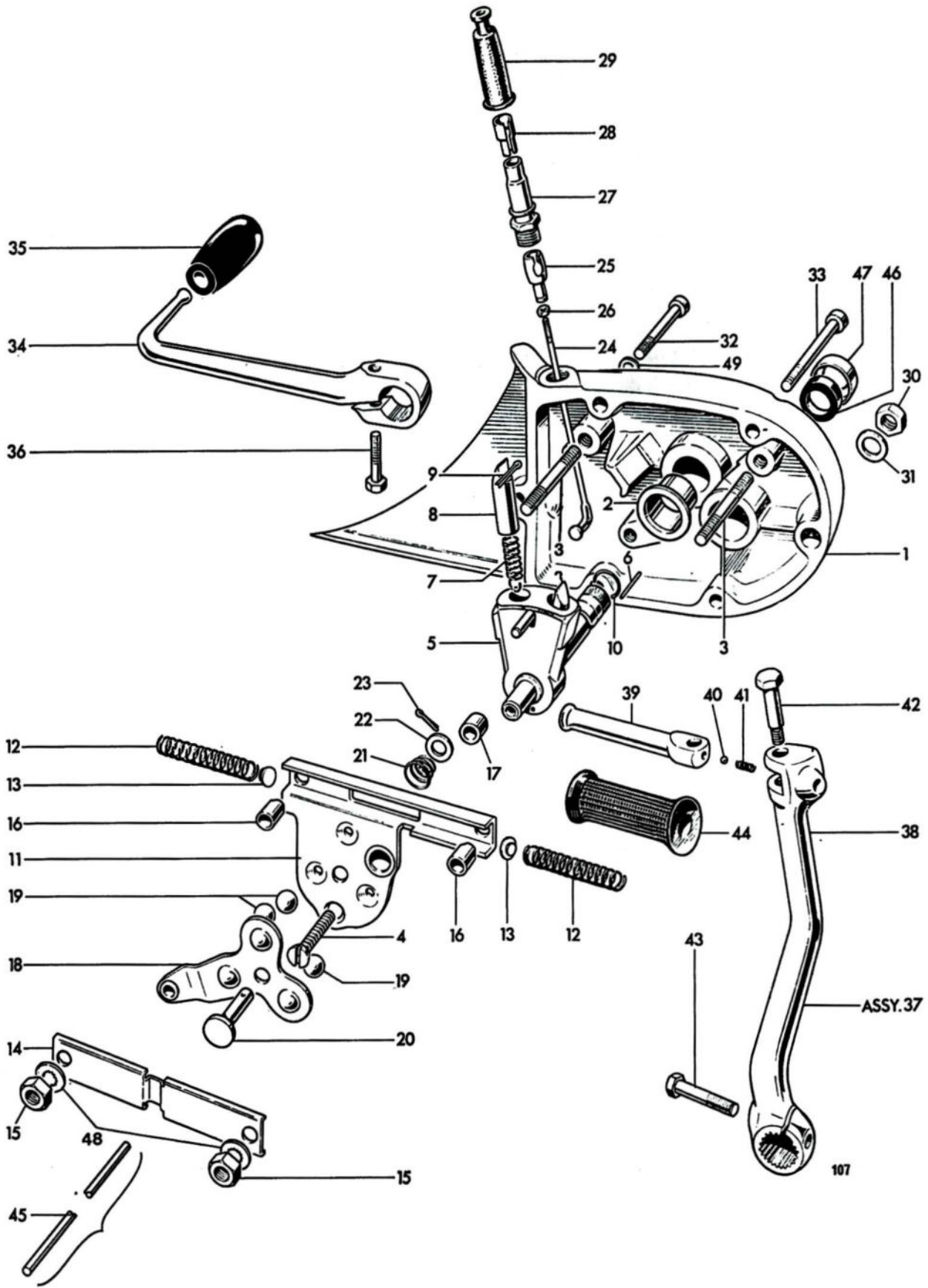
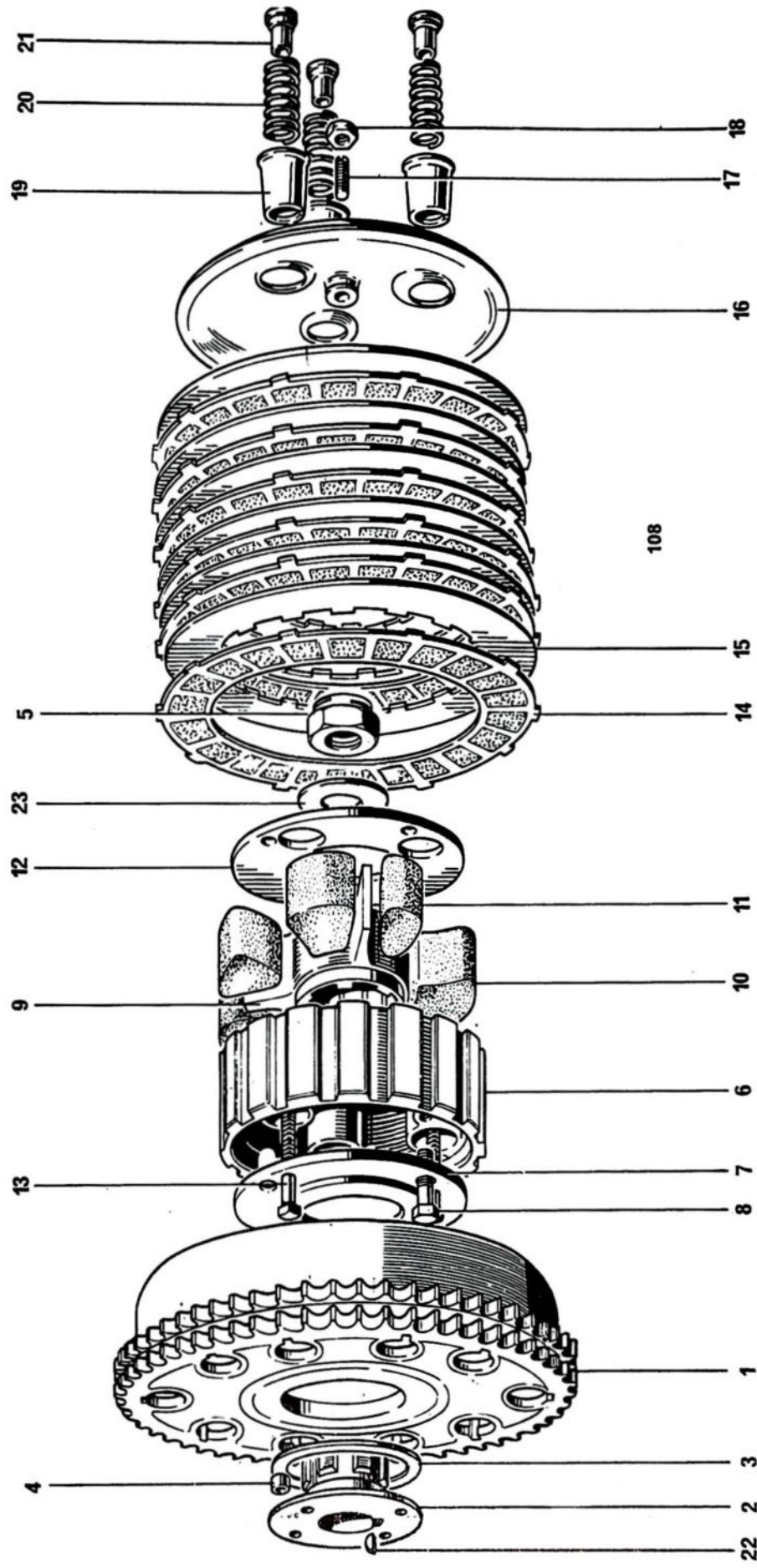

Fig. 9. GEARBOX OUTER COVER AND LEVERS

Ref. No. Part No. DESCRIPTION QUANTITY

GEARBOX OUTER COVER AND LEVERS

1	57-3755	GEARBOX OUTER COVER	1
2	57-1395	Gearchange spindle bush... ..	1
3	21-1928	Stud (1 $\frac{5}{16}$ in. O.A.)	2
4	14-6505	Screw	1
5	57-4888	GEARCHANGE QUADRANT	1
6	57-1474	Spring retaining pin	2
7	57-1436	Plunger spring	2
8	57-1396	Selector plunger	2
9	—	Split pin ($\frac{5}{64}$ in. x $\frac{3}{4}$ in.)	References only
10	57-2697	Sealing ring	1
11	57-1871	Return spring housing	1
12	57-1877	Return spring	2
13	57-1878	Thrust button	2
14	57-1977	Cover	1
15	21-1877	Nut	2
16	57-1876	Distance piece	2
17	57-1874	Distance piece	1
18	57-4439	Clutch lever	1
19	60-2368	Ball, $\frac{3}{8}$ in. diam.	3
20	57-1710	Shaft	1
21	57-1712	Spring	1
22	57-3673	Plain washer	1
23	—	Split pin ($\frac{5}{64}$ in. x $\frac{1}{2}$ in.)	Reference only
24	57-1945	Spoke	1
25	57-1946	Connector	1
26	57-1937	Nut	1
27	57-3784	Abutment	1
28	57-2062	Adaptor, short	As required
28	57-2063	Adaptor, long (For cable with short outer)... ..	As required
29	57-1646	Rubber cover	1
30	14-1302	Nut	2
31	60-4247	Plain washer	2
32	21-1918	Screw	2
33	21-1917	Screw	2
34	57-4561	Gearchange lever	1
35	57-2450	Pedal rubber	1
36	37-0932	Bolt (1 in. U.H.)	1
37	57-4503	KICKSTARTER LEVER COMPLETE... ..	1
38	57-4498	Kickstarter crank	1
39	57-1272	Kickstarter pedal	1
40	60-2364	Steel ball ($\frac{1}{4}$ in. diam.)	1
41	57-1167	Index spring	1
42	21-0541	Pivot bolt	1
43	21-0644	Clamp bolt (1 $\frac{5}{16}$ in. U.H.)	1
44	57-2330	Pedal rubber	1
45	57-1970	Clutch operating rod	1
46	57-2239	Oil seal	1
47	57-2238	Oil seal cover	1
48	70-1612	Serrated washer	2
49	60-3963	Washer, cover screws	4



108

Fig. 10. CLUTCH

Ref. No. Part No. DESCRIPTION QUANTITY REMARKS

CLUTCH

1	57-1570	Sprocket and housing	1
2	57-3930	Hub	1
3	57-3931	Thrust washer	1
4	57-0394	Roller	20
5	21-0586	Nut	1
6	57-4438	Centre (Shock absorber body)	1
7	57-4436	Inner plate	1
8	21-2157	Bolt	3
9	57-4636	Shock absorber spider	1
10	57-1722	Drive rubber (large)	3
11	57-1723	Rebound rubber (small)	3
12	57-4437	Outer plate	1
13	57-423A	Screwed pin (1 $\frac{3}{8}$ in. U.H.)	3
14	57-4763	Driving plate (bonded)	6
15	57-1363	Driven plate (plain)	6
16	57-2156	Pressure plate	1
17	57-2159	Adjuster pin	1
18	14-0403	Nut	1
19	57-1931	Spring cup	3
20	57-1560	Spring	3
21	57-2526	Nut	3
22	60-4253	Key	1
23	57-2279	Washer	1

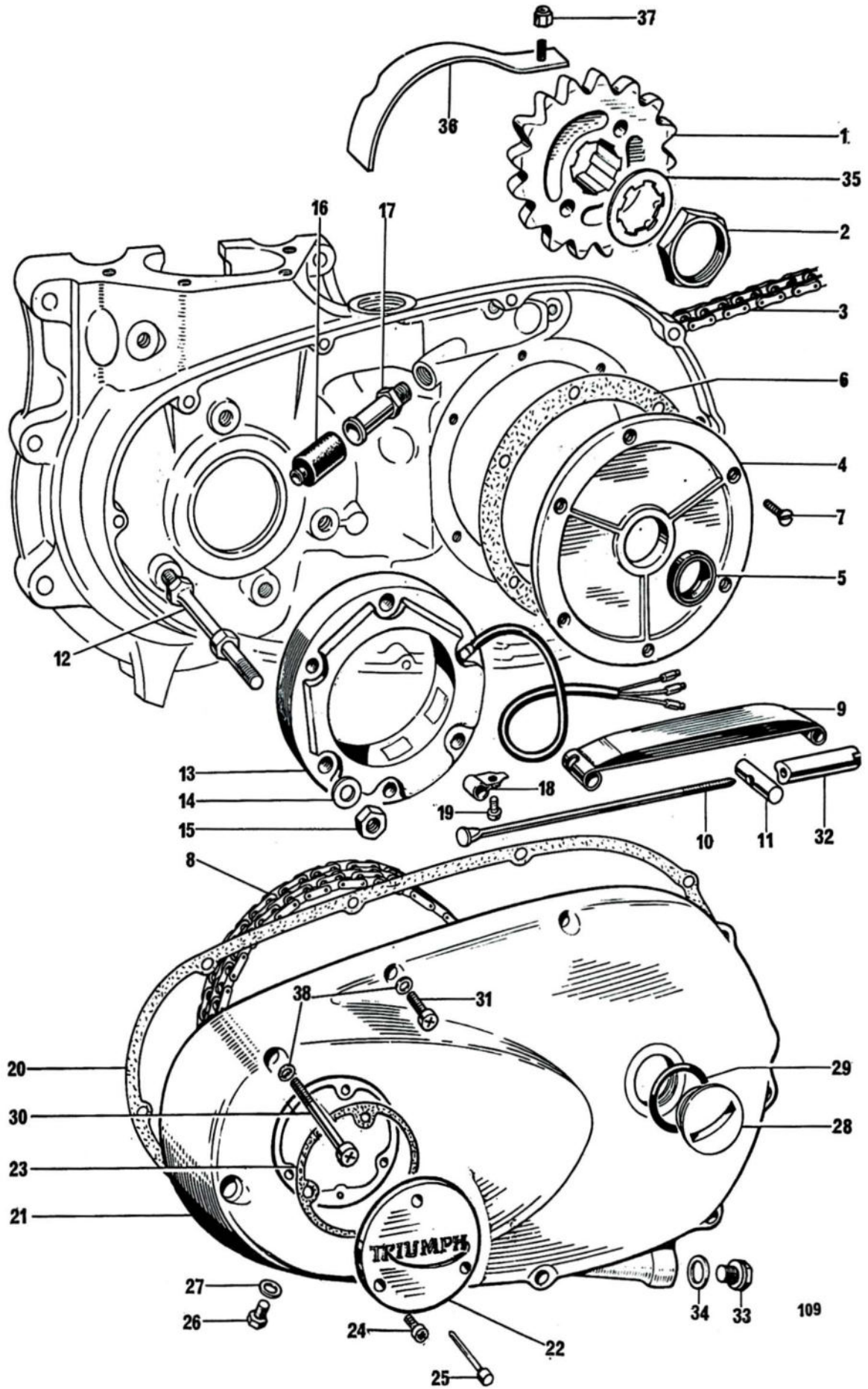

Fig. 11. CHAINCASE AND CHAINS

Ref. No.	Part No.	DESCRIPTION	QUANTITY	REMARKS
CHAINCASE AND CHAINS				
1	57-1558	Gearbox sprocket (17 teeth)	Available	
1	57-1476/18	Gearbox sprocket (18 teeth)	1	
2	57-2536	Gearbox sprocket nut	1	
3	60-3297	Rear chain $\frac{5}{8}$ in. x $\frac{3}{8}$ in. x 110 links	1	
4	70-7037	Cover plate	1	
5	70-7565	Oil seal	1	
6	71-1419	Joint washer	1	
7	70-3821	Countersunk screw ($\frac{5}{16}$ in. U.H.)	6	
8	60-0358	Primary chain, $\frac{3}{8}$ in. Duplex 78 links	1	
9	70-6283	Chain tensioner blade	1	
10	70-4152	Tie rod	1	
11	70-4148	Trunnion	1	
12	70-9495	Stud ($3\frac{5}{16}$ in. O.A.)	3	
13	47205	Stator, RM 21 (99-1006)	1	
14	60-4247	Plain washer	3	
15	14-0702	Nut	3	
16	70-4144	Rubber grommet	1	
17	70-8992	Sleeve nut	1	
18	70-1509	Clip	1	
19	21-1920	Setscrew	1	
20	71-1456	Joint washer	1	
21	70-9249	Chaincase	1	
22	57-2440	Rotor cover	1	
23	71-1457	Joint washer	1	
24	82-4129	Screw	3	
25	57-2537	Ignition pointer... ..	1	
26	14-6101	Level plug	1	
27	70-2441	Copper washer	2	
28	57-2166	Filler plug	1	
29	70-8782	"O" ring	1	
30	21-1878	Screw ($2\frac{3}{4}$ in. U.H.)	3	
31	14-6609	Screw	7	
32	70-9703	Adjuster sleeve nut	1	
33	57-2259	Drain plug	1	
34	70-6299	Fibre washer	1	
35	57-2056	Tab washer	1	
36	70-7571	Crankcase protector	1	
37	14-1301	Self-locking nut	1	
38	60-3963	Washer	14	

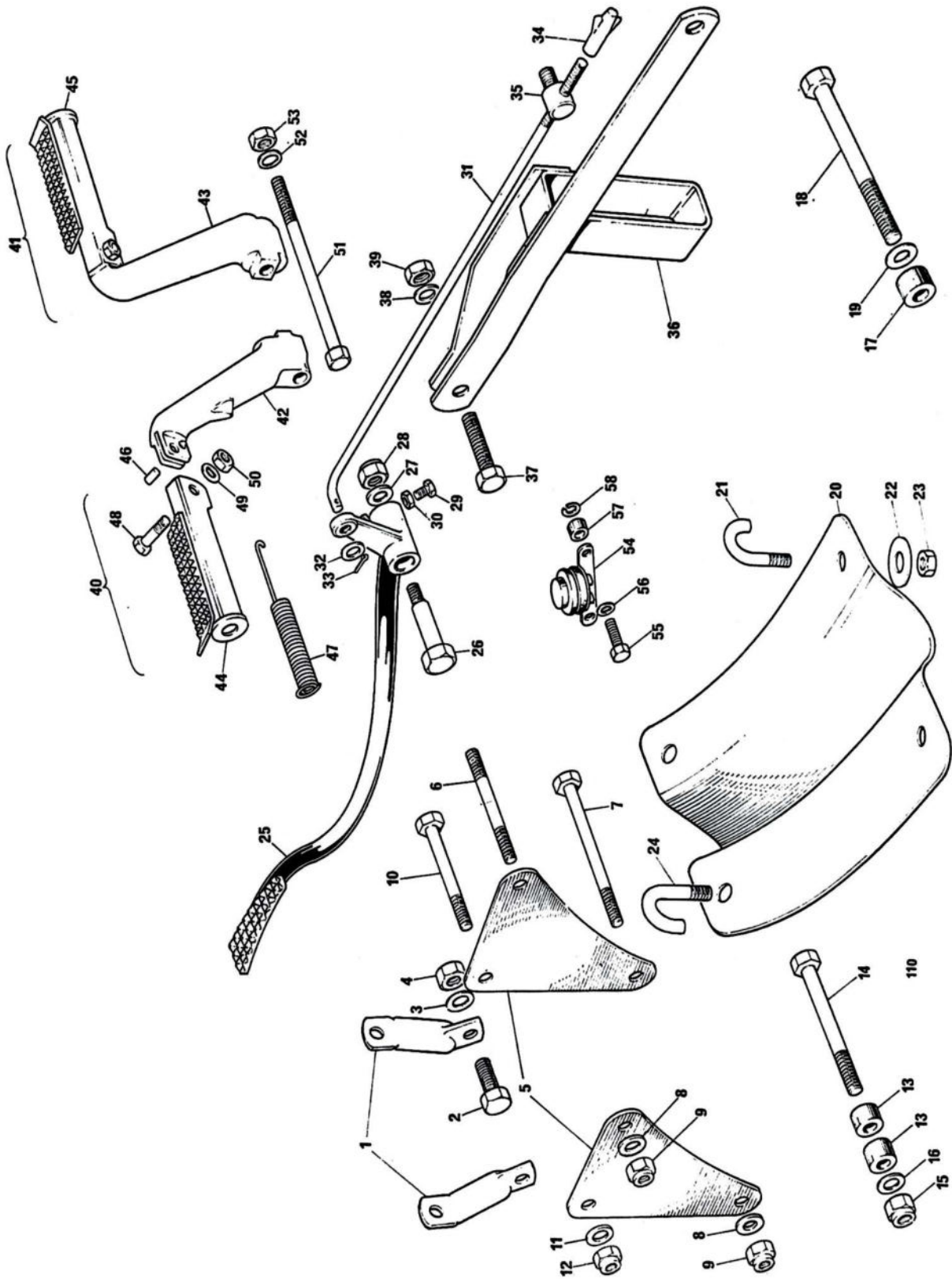

Fig. 12. MOTOR FIXINGS, BRAKE PEDAL AND FOOTRESTS

MOTOR FIXINGS, BRAKE PEDAL AND FOOTRESTS

Ref. No.	Part No.	DESCRIPTION	QUANTITY	REMARKS
1	83-5192	Motor steady strap - L.H.	1	
1	83-5193	Motor steady strap - R.H.	1	
2	14-0113	Bolt	1	
3	60-2339	Washer	1	Steady strap to frame
4	14-1302	Nut	1	
5	83-3590	Motor plate—front	2	
6	21-2217	Stud	1	Motor plates to crankcase
7	14-0225	Bolt	1	
8	60-4247	Washer	3	
9	14-0302	Nut	3	
10	14-0239	Bolt	1	Motor plates to frame
11	60-2331	Washer	1	
12	14-1303	Nut	1	
13	37-2338	Spacer	2	Motor fixing—bottom
14	14-0243	Bolt	1	
15	14-1303	Nut	1	
16	60-2331	Washer	2	Motor fixing—rear
17	83-4210	Spacer	1	
18	21-2152	Bolt	1	
19	70-2288	Washer	1	
20	83-5174	Crankcase undershield...	1	
21	21-2155	'U' bolt	2	Crankcase undershield to frame
22	60-2320	Washer	4	
23	14-1301	Nut	4	
24	21-2221	'U' Bolt	2	
25	83-4747	Rear brake pedal	1	
26	21-2045	Pivot pin...	1	
27	70-8084	Washer	1	
28	14-1303	Nut	1	
29	14-0105	Adjuster screw	1	
30	14-0401	Adjuster nut	1	
31	83-2616	Brake rod	1	
32	83-4277	Distance piece	1	
33	—	Split pin ($\frac{1}{16}$ in. x $\frac{3}{8}$ in.)		Reference only
34	82-7387	Adjuster nut	1	
35	37-1467	Pivot pin...	1	
36	83-4218	Chain guide and torque arm assembly	1	
37	14-0129	Bolt	1	Torque arm front attachment
38	70-1330	Washer	1	
39	14-1303	Nut	1	
40	83-4749	FOLDING FOOTREST ASSEMBLY—L.H.	1	
41	83-4750	FOLDING FOOTREST ASSEMBLY—R.H.	1	
42	83-4663	Footrest bracket—L.H.	1	
43	83-4665	Footrest bracket—R.H.	1	
44	83-4684	Footrest—L.H.	1	
45	83-4685	Footrest—R.H.	1	
46	83-3094	Anchor pin...	1	
47	83-3095	Return spring	1	

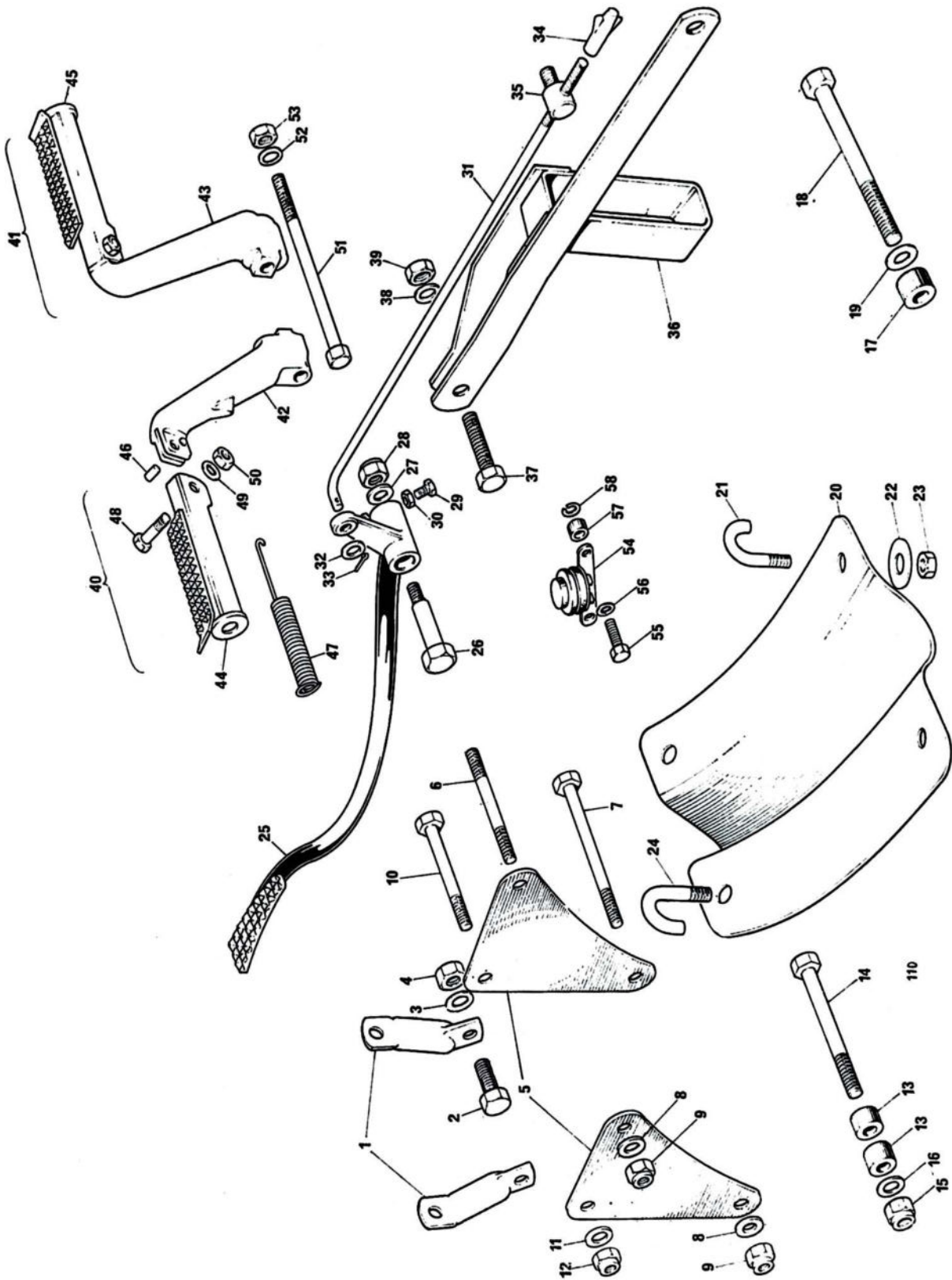

FIG. 12. MOTOR FIXINGS, BRAKE PEDAL AND FOOTRESTS

Ref. No. Part No. DESCRIPTION QUANTITY

MOTOR FIXINGS, BRAKE PEDAL AND FOOTRESTS (continued)

48	21-0512	Bolt	} Footrest to bracket	1
49	60-2321	Washer		1
50	14-1302	Nut		1
51	21-2175	Bolt	} Footrest bracket to frame	1
52	60-2323	Washer		1
53	14-1304	Nut		1
54	34815	Stop light switch (99-1028)	1
55	70-3197	Screw	} Stop light switch attachment	2
56	60-4249	Washer		2
57	82-7044	Distance piece		2
58	60-2426	Spring washer		2

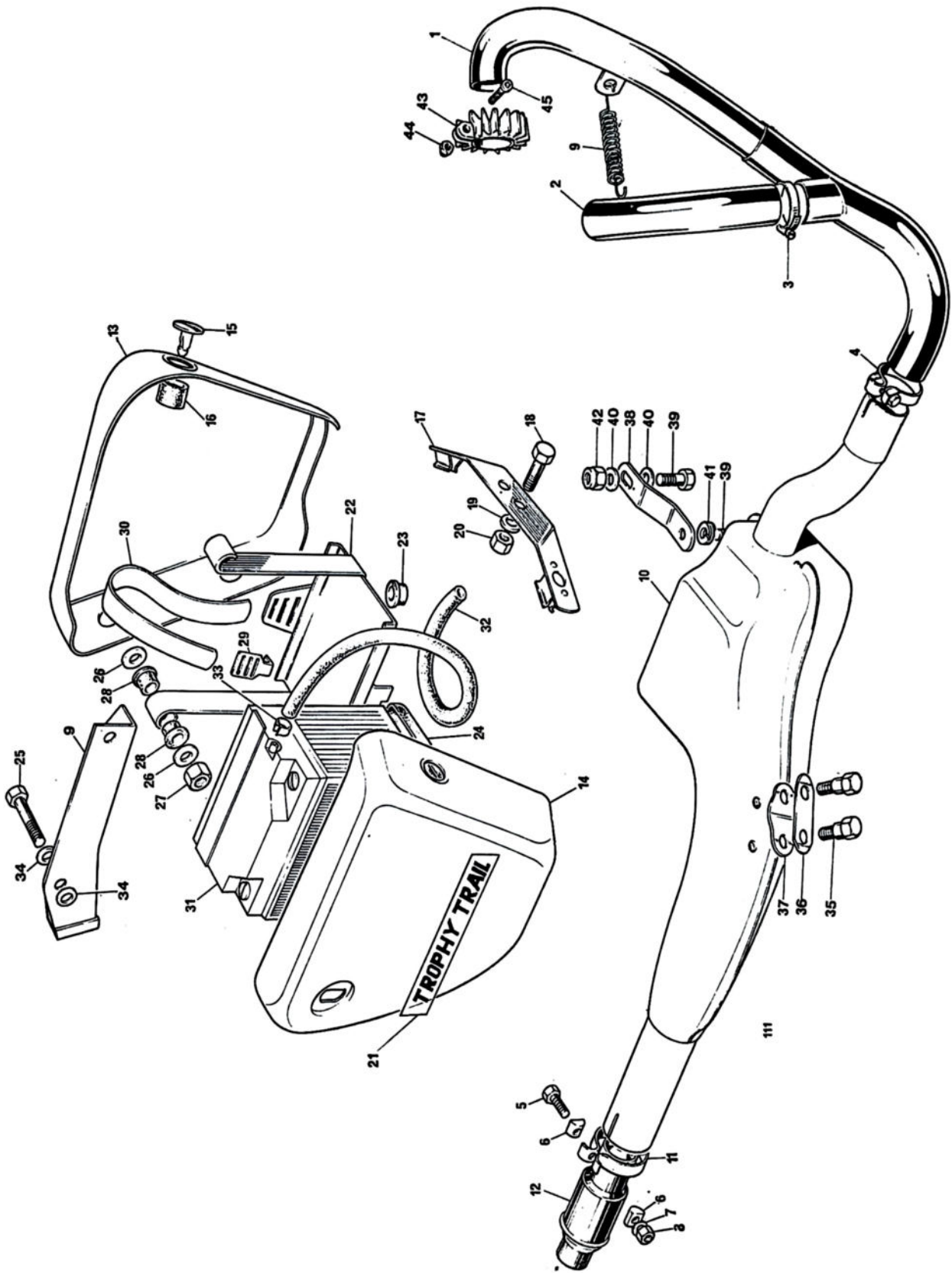

Fig. 13. EXHAUST SYSTEM, SIDE COVERS AND BATTERY

Ref. No. Part No. DESCRIPTION QUANTITY

EXHAUST SYSTEM SIDE COVERS AND BATTERY

1	71-3764	Exhaust pipe - L.H.	1
2	71-3765	Exhaust pipe - R.H.	1
3	70-7512	Clip	2
4	70-5874	Clip	1
5	14-0220	Bolt	} Exhaust pipes and Muffler clips	3
6	70-3768	"D" Washer		6
7	82-8981	Washer		3
8	14-1202	Nut		3
9	83-4113	Tool tray	1
10	71-3793	Muffler	1
11	71-3524	Clip	1
12	60-4303	Tailpipe (Krizman KS 500)	1
13	83-4906	Side cover—L.H.	1
14	83-5122	Side cover—R.H.	1
15	OF522	Oddie fastener	Reference only
16	OF618	Rubber washer	Reference only
17	83-4905	Front fixing bracket	1
18	14-0102	Bolt	} Front fixing bracket	2
19	21-0602	Washer		2
20	14-1301	Nut		2
21	60-4352	Transfer	2
22	83-2018	Battery carrier	1
23	83-2006	Locating rubber	4
24	82-9003	Support tray rubber	1
25	21-2060	Bolt	} Carrier support	2
26	83-1829	Washer		4
27	14-1301	Nut		2
28	83-2204	Rubber		4
29	82-9004	Battery strap hook	1
30	82-9005	Battery strap	1
31	54027029	Battery PUZ 5A (99-0719)	1
32	60-0980	Vent pipe	1
33	60-0981	Clip	1
34	60-2347	Washer	4
35	21-2208	Bolt	} Muffler attachment—R.H.	2
36	83-4913	Tab washer		1
37	71-3561	Spring plate		1
38	83-4912	Support strap	} Muffler attachment—L.H.	1
39	14-0114	Bolt		2
40	60-2438	Washer		1
41	60-2339	Washer		2
42	14-1302	Nut	} Exhaust pipe attachment	1
43	71-2466	Finned clip		2
44	21-0778	Nut		2
45	21-2186	Screw	2

ALTERNATIVE FITMENTS (NOT U.S.A.)

60-4296	Transfer, Adventurer	2
---------	----------------------	-----	-----	-----	-----	-----	-----	-----	---

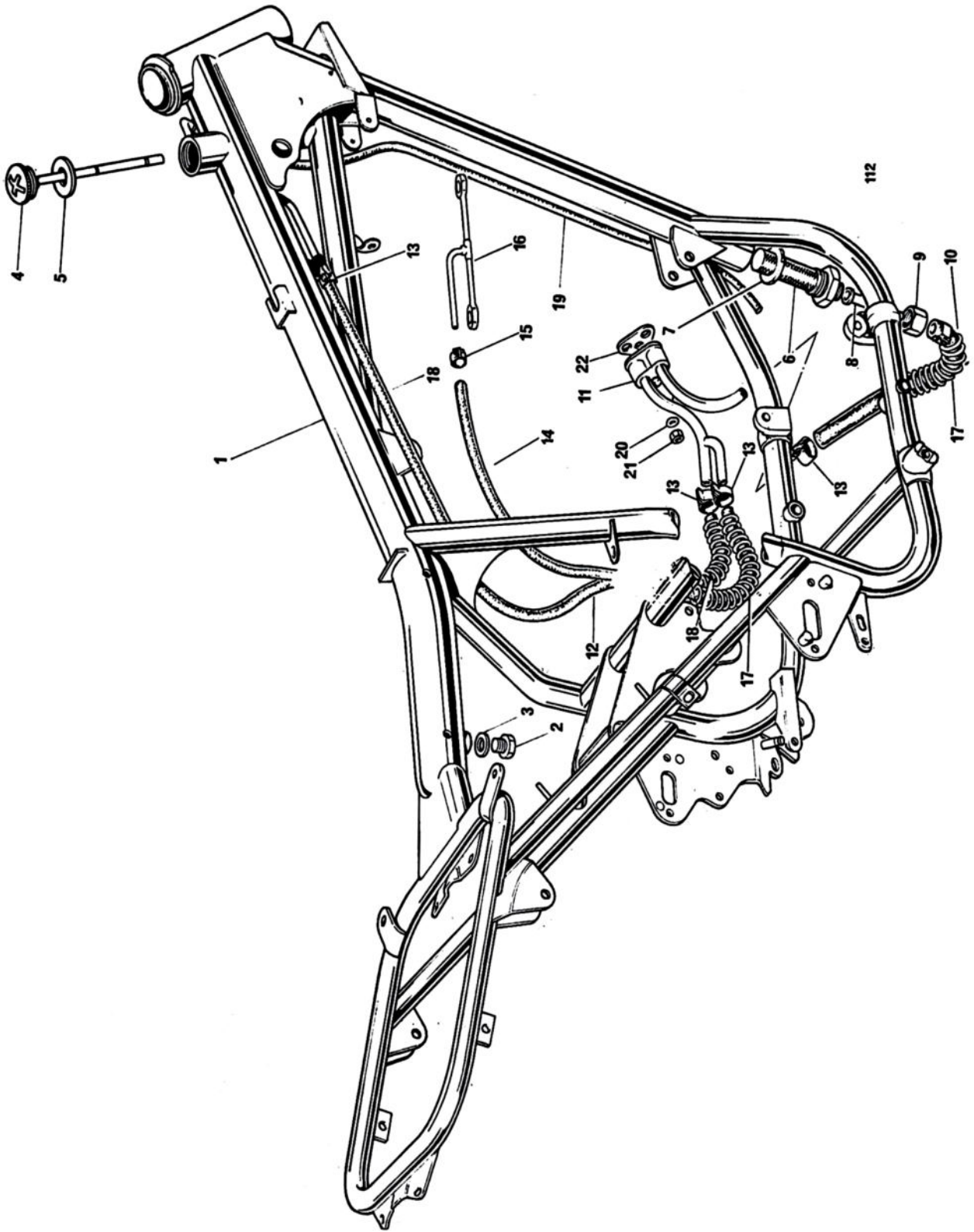

Fig. 14. FRAME

Ref. No. Part No. DESCRIPTION QUANTITY

FRAME

1	83-4188	Frame	1
2	21-2015	Drain plug	1
3	71-2505	Joint washer	1
4	83-3046	Filler cap and dipstick assembly	1
5	60-3616	Joint washer	1
6	82-9430	Oil tank filter	1
7	82-1713	Joint washer	1
8	71-3639	Oil feed pipe (at filter)	1
9	82-3182	Union nut—feed pipe	1
10	71-3640	Oil feed pipe—flexible... ..	1
11	71-3071	Oil pipe junction block	1
12	83-3076	Oil return pipe—flexible	1
13	70-6848	Clip—oil pipes	4
14	70-8106	Rocker feed pipe—flexible	1
15	70-8111	Clip—rocker feed pipe	1
16	71-3084	Rocker connecting pipe	1
17	83-4380	Protection spring—feed and return pipes	2
18	83-4381	Protection spring—rocker feed pipe	1
19	83-4911	Breather pipe	1
20	70-3446	Washer } Oil junction block to crankcase	1
21	21-1908	Nut }	1
22	71-3754	Joint washer	1

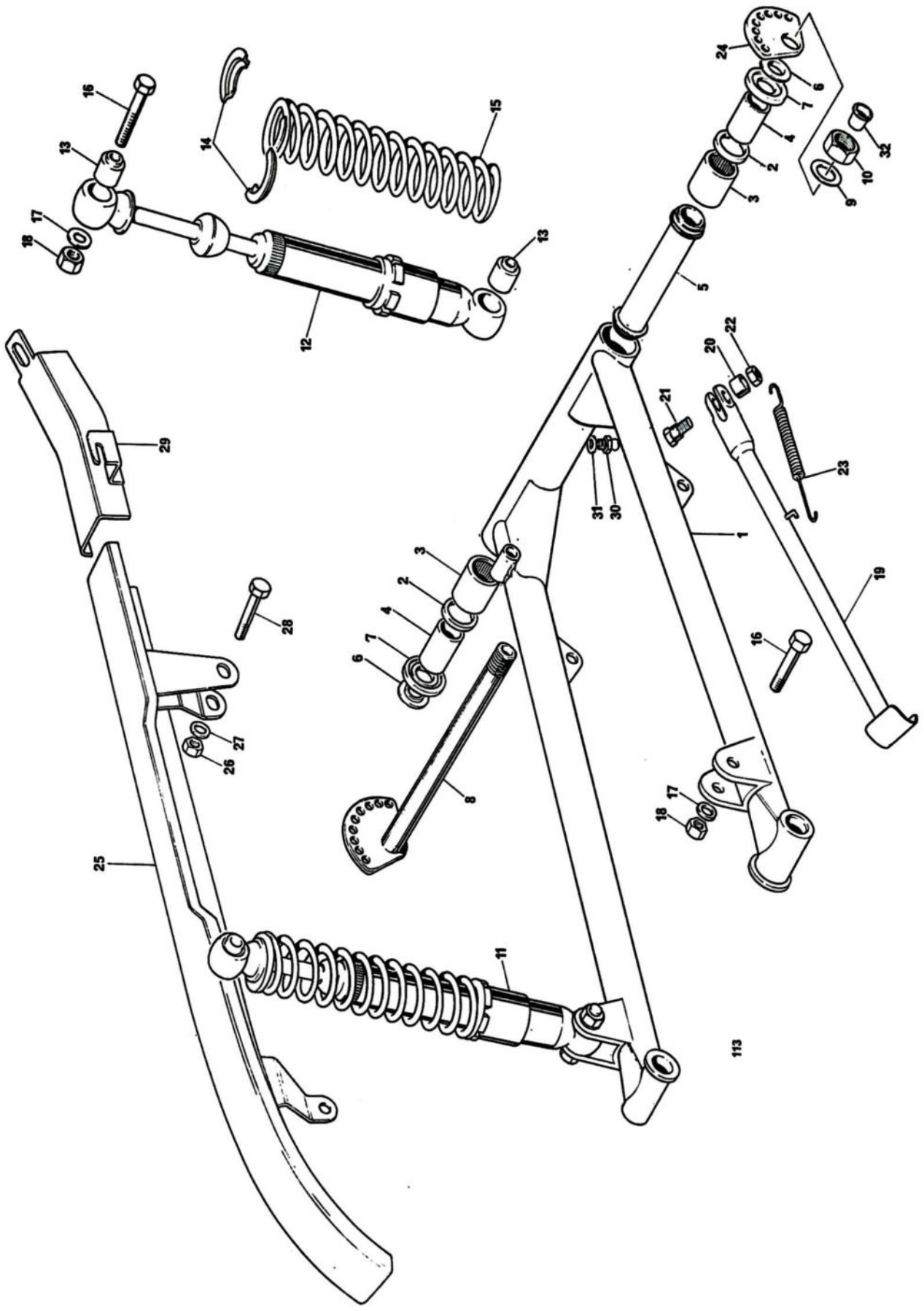

Fig. 15. SWINGING ARM AND SUSPENSION UNITS

Ref. No. Part No. DESCRIPTION QUANTITY REMARKS

SWINGING ARM AND SUSPENSION UNITS

1	83-4180	Swinging arm	1	
2	83-2244	Oil seal	2	
3	83-2245	Bearing	2	
4	83-2012	Sleeve	2	
5	83-1969	Spacer tube	1	
6	83-2233	Thrust washer	2	
7	83-3014	Seal	2	
8	83-3554	Spindle	1	
9	37-2085	Washer	1	
10	21-0755	Nut	1	
11	64052453	Suspension unit (D3116)	2	
12	2455	Damper unit (99-1185)	2	
13	64533	Bonded bush (99-1186)	4	
14	9054/171	Spring retainer (99-0107)	4	
15	64543708	Spring (100 lb.)(G.G.)(99-1048)	4	
16	21-0684	Bolt	2	} Suspension unit fixings
16	14-0234	Bolt	2	
17	60-2331	Washer	4	
18	14-1303	Nut	4	
19	83-4278	Prop stand	1	
20	83-3165	Distance piece	1	
21	21-2105	Screw	1	
22	14-1303	Nut	1	
23	83-2896	Spring	1	
24	83-3556	Adjuster, rear chain	1	
25	83-2224	Rear chainguard	1	
26	14-1302	Nut	1	} Chainguard to swinging arm
27	60-2339	Washer	1	
28	14-0221	Bolt	1	
29	83-4461	Chainguard extension	1	
30	60-3931	Grease nipple	1	
31	71-2501	Fibre washer	1	
32	60-4348	Plug, Swinging arm spindle	2	

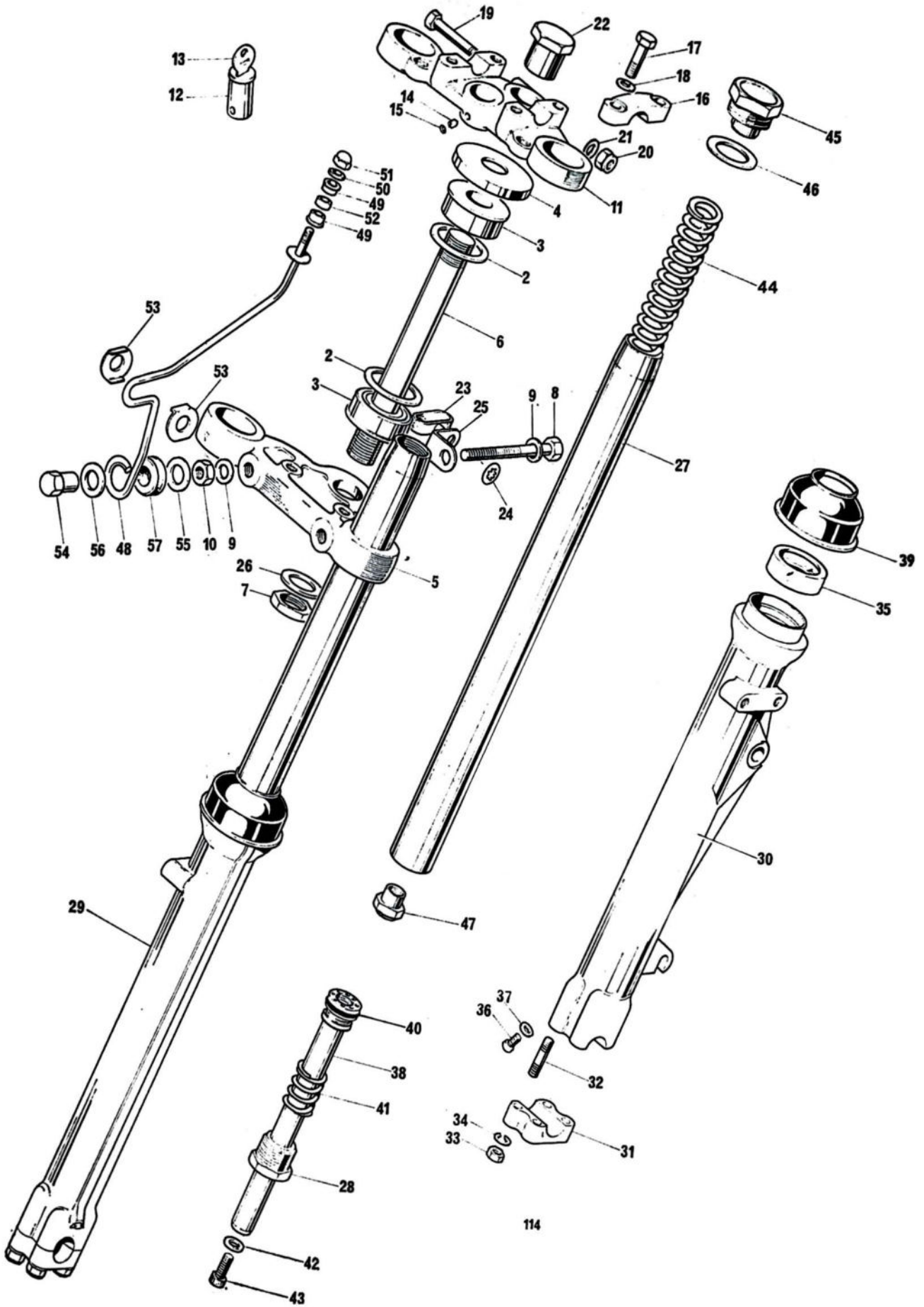

Fig. 16. TELESCOPIC FRONT FORK

Ref. No.	Part No.	DESCRIPTION	QUANTITY	REMARKS
TELESCOPIC FORKS				
1	97-4332	FORK ASSEMBLY	1	
2	83-2007	Abutment ring	2	
3	97-4031	Bearing	2	
4	97-4028	Dust cover	1	
5	97-4313	Bottom yoke	1	
6	97-4319	Steering stem	1	
7	14-7308	Steering stem nut (bottom)	1	
8	14-0240	Pinch bolt	2	} Bottom yoke
9	21-2138	Washer	4	
10	14-1203	Nut	2	
11	97-3985	Top yoke	1	
12	82-6738	Anti theft lock c/w key	1	
13	60-0623	Key (state serial no.)	1	
14	21-0578	Grub screw	1	
15	97-2266	Sealing washer	1	
16	97-0722	Handlebar cap	2	
17	14-6219	Bolt	4	
18	83-3549	Washer	4	
19	14-0236	Pinch bolt	1	} Top yoke
20	14-1303	Nut	1	
21	70-8084	Washer	1	
22	97-4317	Steering stem nut	1	
23	97-2270	Brake cable retainer	2	
24	82-8245	Washer	2	
25	97-3682	Retaining bracket	2	
26	60-2336	Washer—bottom steering stem nut	1	
27	97-4455	Stanchion	2	
28	97-4076	End plug	2	
29	97-4342	OUTER MEMBER—L.H.	1	
30	97-4344	OUTER MEMBER—R.H.	1	
31	97-3947	Cap—wheel spindle	2	
32	21-2102	Stud	8	
33	14-0302	Nut	8	
34	60-2428	Washer	8	
35	97-4001	Oil seal outer member	2	
36	97-3894	Drain plug	2	
37	97-3893	Washer	2	
38	97-4325	Damper tube and valve assembly	2	
39	97-4002	Scraper sleeve	2	
40	97-4003	"O" ring	2	
41	97-4009	Spring	2	
42	97-4004	Sealing washer	2	
43	14-1019	Bolt	2	
44	97-4011	Main spring	2	
45	97-4258	Top cap nut	2	
46	97-4166	Washer, fork top nut	2	
47	97-4012	Nut, damper valve	2	

Ref. No. Part No. DESCRIPTION QUANTITY

TELESCOPIC FORKS (continued)

48	97-4048	Headlamp bracket—L.H.	1
48	97-4050	Headlamp bracket—R.H.	1
49	83-2209	Headlamp mounting bush	4
50	60-2338	Washer			2
51	21-1809	Nut	}	Headlamp bracket—top fixing		2
52	83-2211	Spacer		2	
53	83-2210	Clamp washer	4
54	21-2062	Sleeve nut	}	Headlamp bracket—bottom fixing		2
55	82-9046	Washer		2	
56	60-2333	Washer		2	
57	60-2630	Rubber grommet		2	

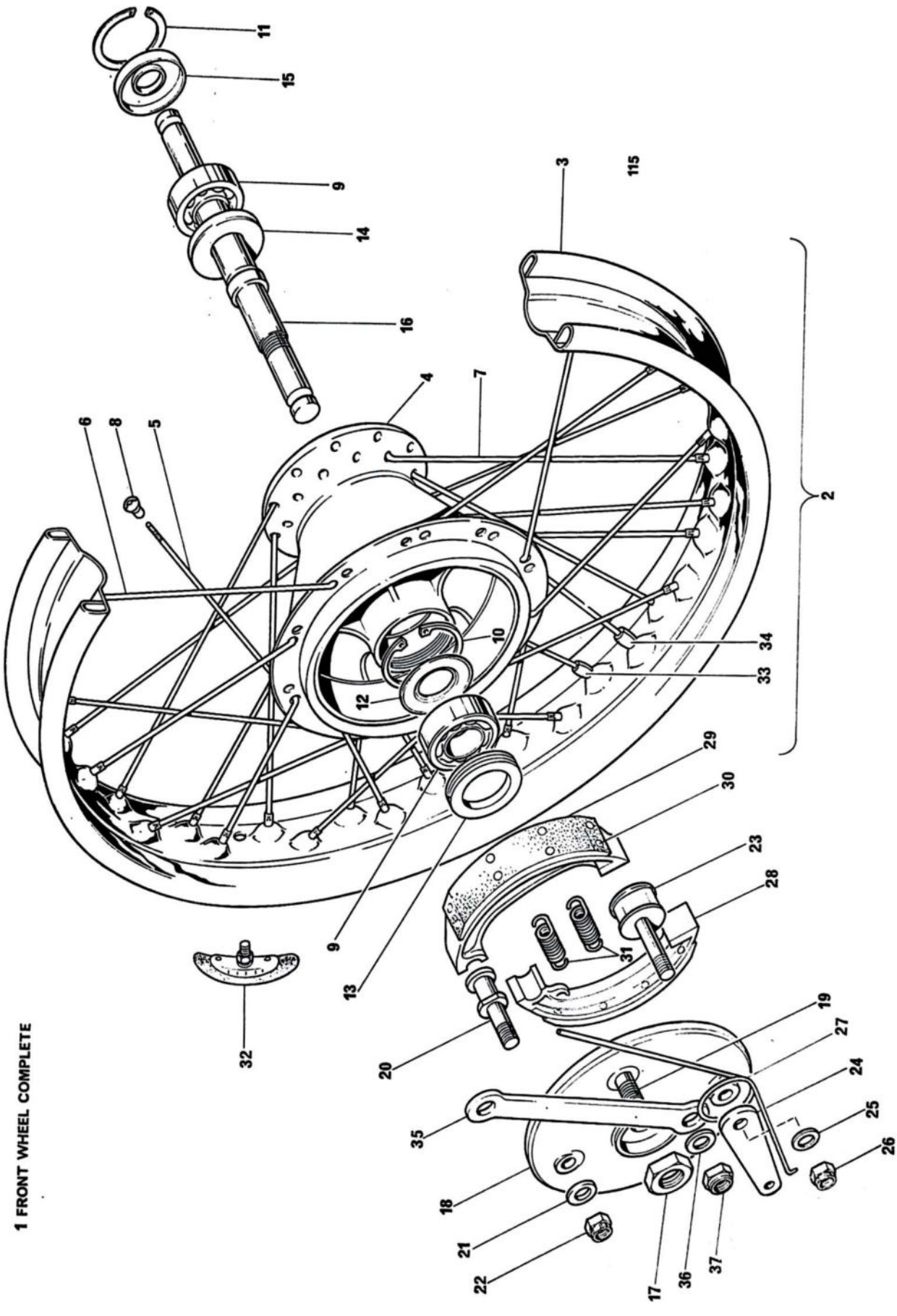

Fig. 17. FRONT WHEEL

Ref. No.	Part No.	DESCRIPTION	QUANTITY	REMARKS
FRONT WHEEL				
1	37-4149	FRONT WHEEL COMPLETE	1	
2	37-4150	RIM, SPOKES AND HUB ASSEMBLY	1	
3	37-4151	Front wheel rim (WM 1 x 21)	1	
4	37-3702	Brake drum and hub	1	
5	37-4152	Spoke (R.H. inner)	10	
6	37-4131	Spoke (R.H. outer)	10	
7	37-4154	Spoke (L.H.)	20	
8	37-2294	Nipple... ..	40	
9	37-0653	Bearing	2	
10	60-2632	Circlip—R.H.	2	
11	57-0280	Circlip—L.H.	1	
12	37-3797	Grease retainer	1	
13	37-3759	Locking ring	1	
14	37-1481	Grease cap (inner)	1	
15	37-1237	Grease cap (outer)	1	
16	37-3796	Spindle	1	
17	37-2058	Spindle locknut	1	
18	37-4163	Brake anchor plate	1	
19	21-2063	Stud-anchor plate torque reaction	1	
20	37-3798	Fulcrum pin	1	
21	60-2331	Washer } Anchor plate	1	
22	14-1303	Nut }	1	
23	37-3799	Brake cam	1	
24	37-3694	Brake lever	1	
25	60-2331	Washer } Brake lever	1	
26	14-1303	Nut }	1	
27	37-4107	Return spring	1	
28	37-3804	BRAKE SHOE C/W LINING	2	
29	Reference only	Lining	1	} each shoe
30	Reference only	Rivet	8	
31	37-2328	Return spring	2	
32	37-3584	Security bolt	1	
33	37-3969	Balance weight (½ oz.)	As required	
34	37-3970	Balance weight (1 oz.)	As required	
35	83-2660	Front brake anchor strap	1	
36	60-2332	Washer } Anchor strap	2	
37	14-1304	Nut }	2	

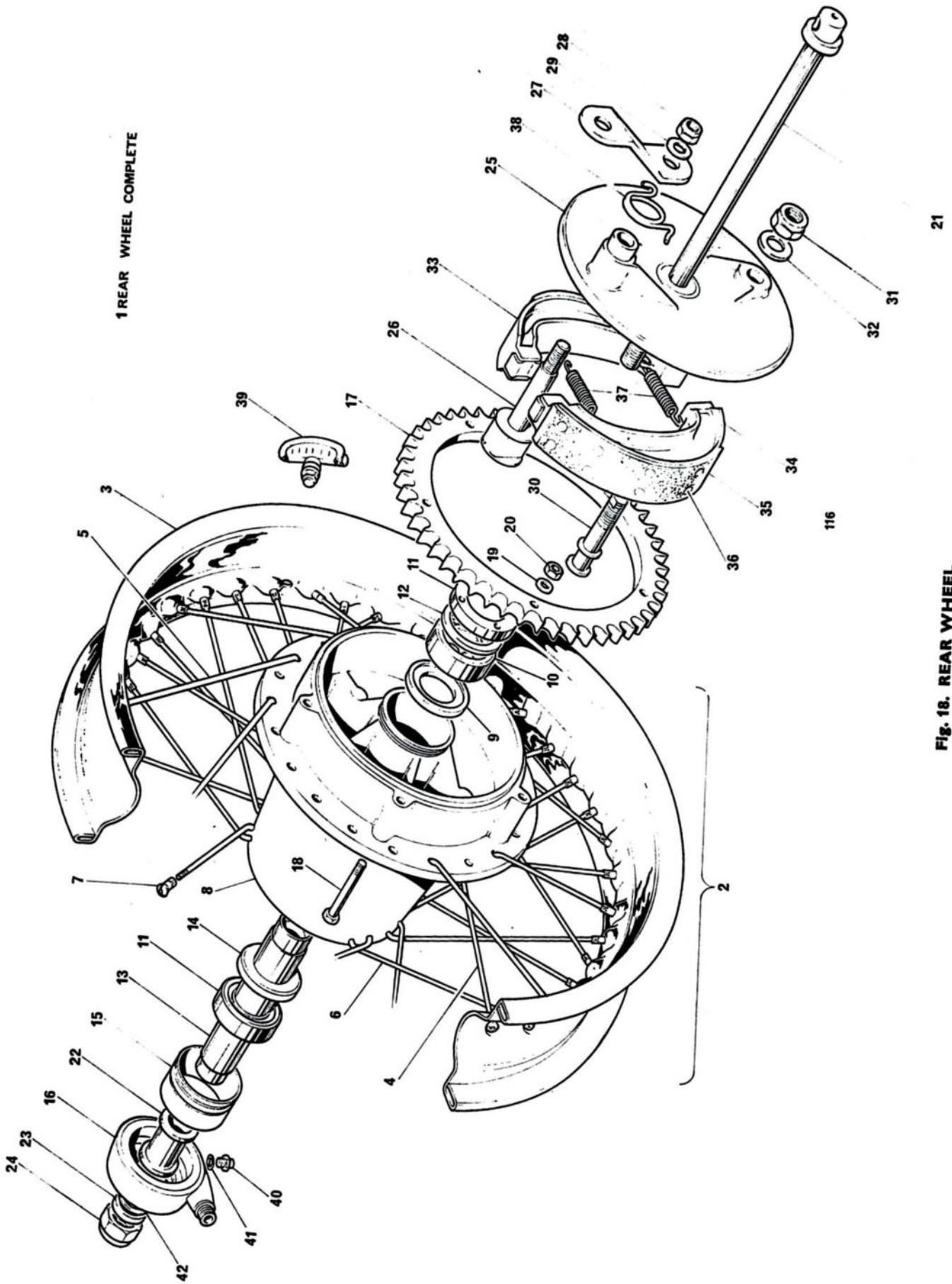

FIG. 18. REAR WHEEL

Ref. No.	Part No.	DESCRIPTION	QUANTITY	REMARKS
REAR WHEEL				
1	37-4249	REAR WHEEL COMPLETE	1	
2	37-4182	Rim, spokes and hub assembly	1	
3	37-3784	Rim (WM 3 x 18)	1	
4	37-3724	Spoke (L.H. inner)	10	
5	37-3725	Spoke (L.H. outer)	10	
6	37-3726	Spoke (R.H.)	20	
7	37-2294	Nipple... ..	40	
8	37-4179	Drum and hub	1	
9	37-3749	Bearing support ring	1	
10	37-0653	Bearing	2	
11	37-4181	Locking ring	1	
12	37-4180	Spacer	1	
13	37-3753	Bearing spacer	1	
14	37-1654	Grease retainer	1	
15	37-3751	Speedometer drive ring	1	
16	60-3215	Speedometer gearbox (BG5330/104)	1	
17	37-4140	Rear wheel sprocket—53T	1	
18	14-0207	Bolt	5	
19	60-2320	Washer } Sprocket to hub	5	
20	14-1301	Nut }	5	
21	37-3977	Spindle	1	
22	37-3750	Distance piece	1	
23	83-2266	Washer—spindle	1	
24	14-1307	Nut—spindle	1	
25	37-3857	Brake anchor plate	1	
26	37-4145	Brake cam	1	
27	37-4147	Brake lever	1	
28	14-1303	Nut } Brake lever	1	
29	60-2331	Washer }	1	
30	37-3870	Rear brake pivot	1	
31	14-0305	Nut } Torque arm to pivot	1	
32	60-2431	Washer }	1	
33	37-3925	BRAKE SHOE C/W LINING (Leading)	1	
34	37-3926	BRAKE SHOE C/W LINING (Trailing)	1	
35	Reference only	Lining	1	} each shoe
36	Reference only	Rivet	8	
37	37-2328	Return spring—brake shoe	2	
38	37-4049	Return spring—brake lever	1	
39	37-3468	Security bolt	2	
40	60-1841	Grease nipple	1	
41	71-2501	Fibre washer	1	
42	60-2335	Washer, speedometer, gearbox	1	

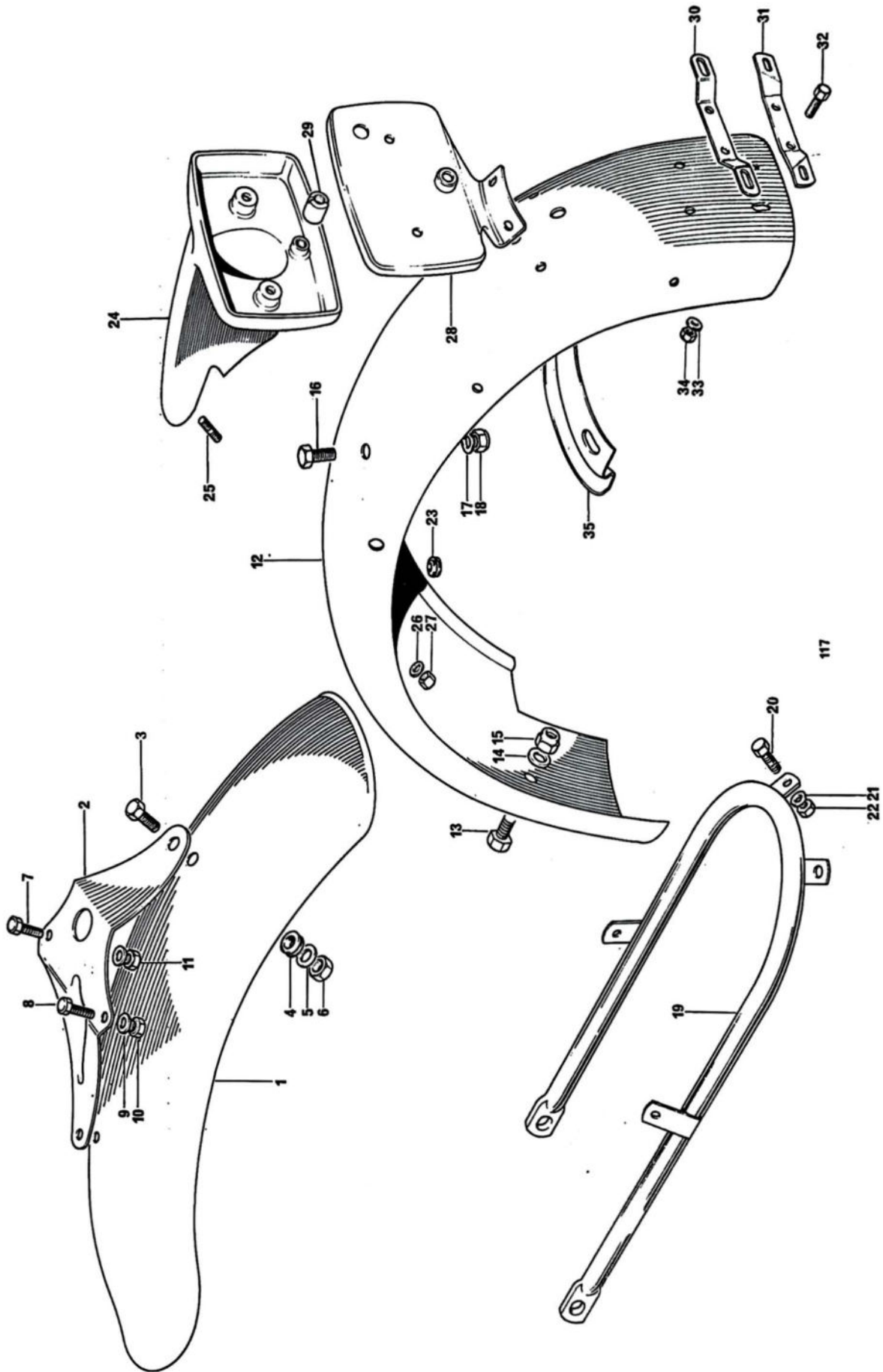

Fig. 19. FENDERS

Ref. No. Part No. DESCRIPTION QUANTITY

FENDERS

1	97-4333	Front fender	1
2	97-4359	Support bracket	1
3	14-0114	Bolt	}	Fender to support bracket	2
4	60-3242	Grommet			2
5	60-2348	Washer			2
6	14-1302	Nut			2
7	14-6114	Bolt			1
8	14-6118	Bolt			1
9	60-2348	Washer	}	Support bracket to bottom yoke	2	
10	14-7302	Nut			1	
11	14-1302	Nut			1	
12	83-4848	Rear fender	1	
13	14-0101	Bolt	}	Rear fender attachment—bottom	1	
14	60-2347	Washer			2	
15	14-1301	Nut			1	
16	14-0101	Bolt	}	Rear fender attachment—top	4	
17	60-2347	Washer			8	
18	14-1301	Nut			4	
19	83-4758	Lifting handle	1	
20	14-0102	Bolt	}	Lifting handle to rear fender	2	
21	60-2347	Washer			4	
22	14-1301	Nut			2	
23	97-0961	Grommet	3	
24	83-4774	Tail lamp support	1	
25	21-2225	Stud	}	Tail lamp support to fender	1	
26	60-4250	Washer			1	
27	14-0301	Nut			1	
28	83-5001	Support plate	1	
Not illus.	14-7804	Screw—support plate	1	
29	83-4800	Nut—tail lamp attachment	2	
30	83-4784	Rear no. plate bracket—top	1	
31	82-6850	Rear no. plate bracket—bottom	1	
32	14-0102	Bolt	}	No. plate brackets to fender	4	
33	60-2329	Washer			4	
34	14-1301	Nut			4	
35	83-4806	Wiring protector	1	
Not illus.	83-5105	Grommet tail lamp support	2	

ALTERNATIVE FITMENTS (NOT U.S.A.)

83-2834	Front Number Plate	1 off
57-1076	Screw, Number Plate	2 off
60-4249	Washer, Number Plate	2 off
83-2726	Rear Number Plate	1 off
14-0101	Bolt, Number Plate	4 off
60-2329	Washer, Number Plate	4 off
14-1301	Nut, Number Plate	4 off

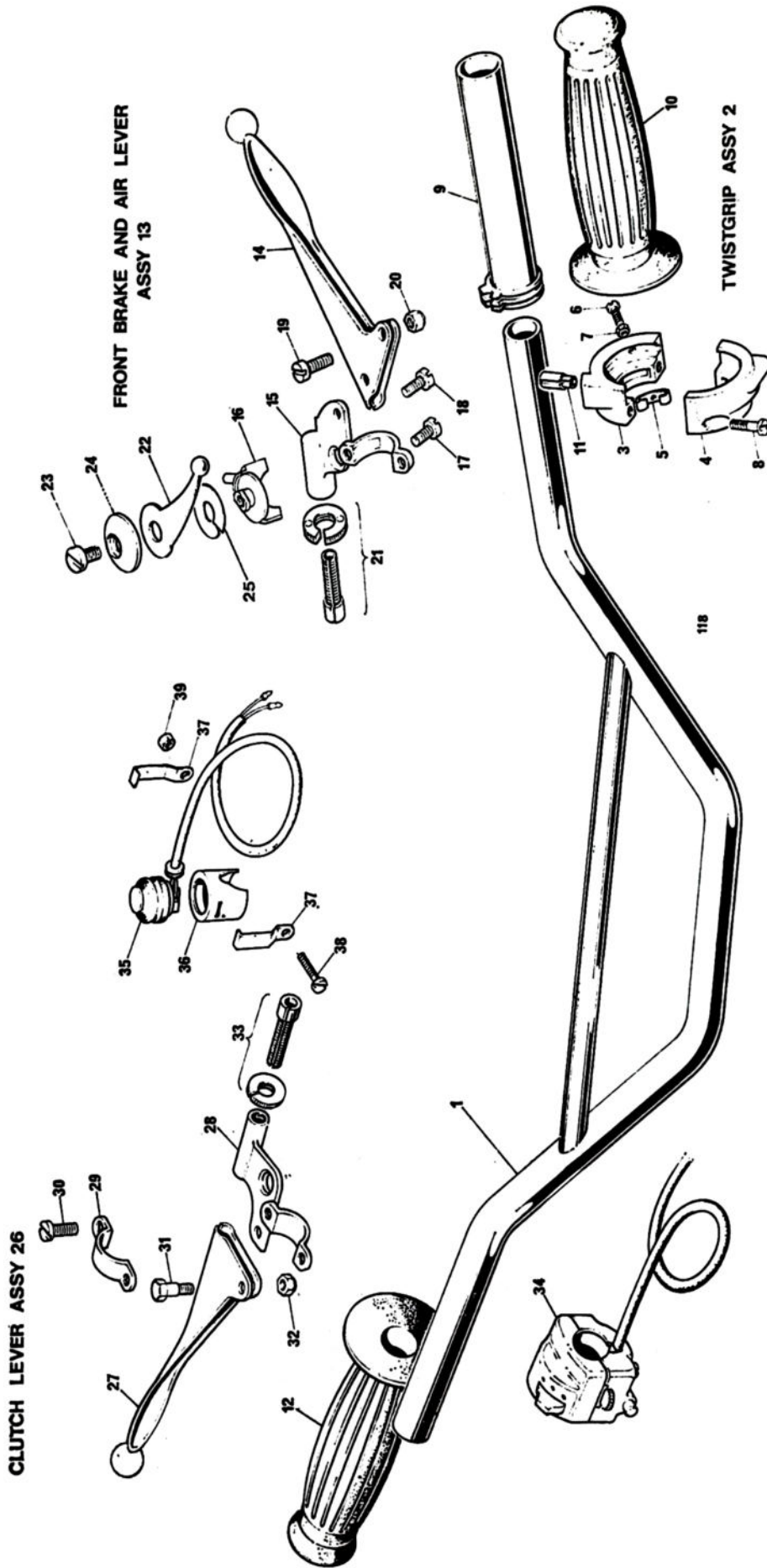

FIG. 20. HANDLEBARS AND CONTROL LEVERS

Ref. No.	Part No.	DESCRIPTION	QUANTITY	REMARKS
HANDLEBARS AND CONTROL LEVERS				
1	97-4062	Handlebar	1	
2	16/364	TWISTGRIP (99-0248)	1	
3	16/328	Body, top half (99-0245)	1	
4	16/329	BODY, BOTTOM HALF (99-0246)	1	
5	16/008	Spring		Reference only
6	16/009	Screw		Reference only
7	16/010	Locknut		Reference only
8	11/014	Screw (99-0226)	2	
9	16/091	Rotor (99-0244)	1	
10	97-2125	Handlebar grip	1	
11	16/011	Cable stop (99-0241)	1	
12	97-2124	Handlebar grip—L.H.	1	
13	19/978	FRONT BRAKE AND AIR LEVER ASSEMBLY (60-2241)	1	
14	18/754	Brake lever (ball end) (99-0262)	1	
15	19/001	Lever bracket (99-1093)	1	
16	12/619	Control body (99-0234)	1	
17	11/014	Screw (99-0226)	1	
18	11/013	Screw (99-0225)	1	
19	18/087	Fulcrum screw (99-0252)	1	
20	18/053	Self locking nut (99-0250)	1	
21	18/1708/9	Cable adjuster and nut (99-1031)	1	
22	12/556	Lever (99-0228)	1	
23	12/607	Bolt		Reference only
24	12/606	Cap		Reference only
25	12/033	Spring washer		Reference only
26	19/1098	CLUTCH LEVER ASSEMBLY (60-2242)	1	
27	18/752	Clutch lever (ball end) (99-0261)	1	
28	19/002	Clutch lever bracket (99-1094)	1	
29	12/595	Clamp (99-0230)	1	
30	11/014	Screw (99-0226)	2	
31	18/087	Fulcrum screw (99-0252)	1	
32	18/053	Self locking nut (99-0250)	1	
33	18/1708/9	Cable adjuster and nut (99-1031)	1	
34	60-4001	Handlebar switch (Dip, Flasher, Horn)	1	
35	35835	Cut out switch (99-0564)	1	
36	97-2259	Cup	1	
37	97-2034	Clip	2	
38	97-0687	Screw	1	
39	97-0745	Nut	1	

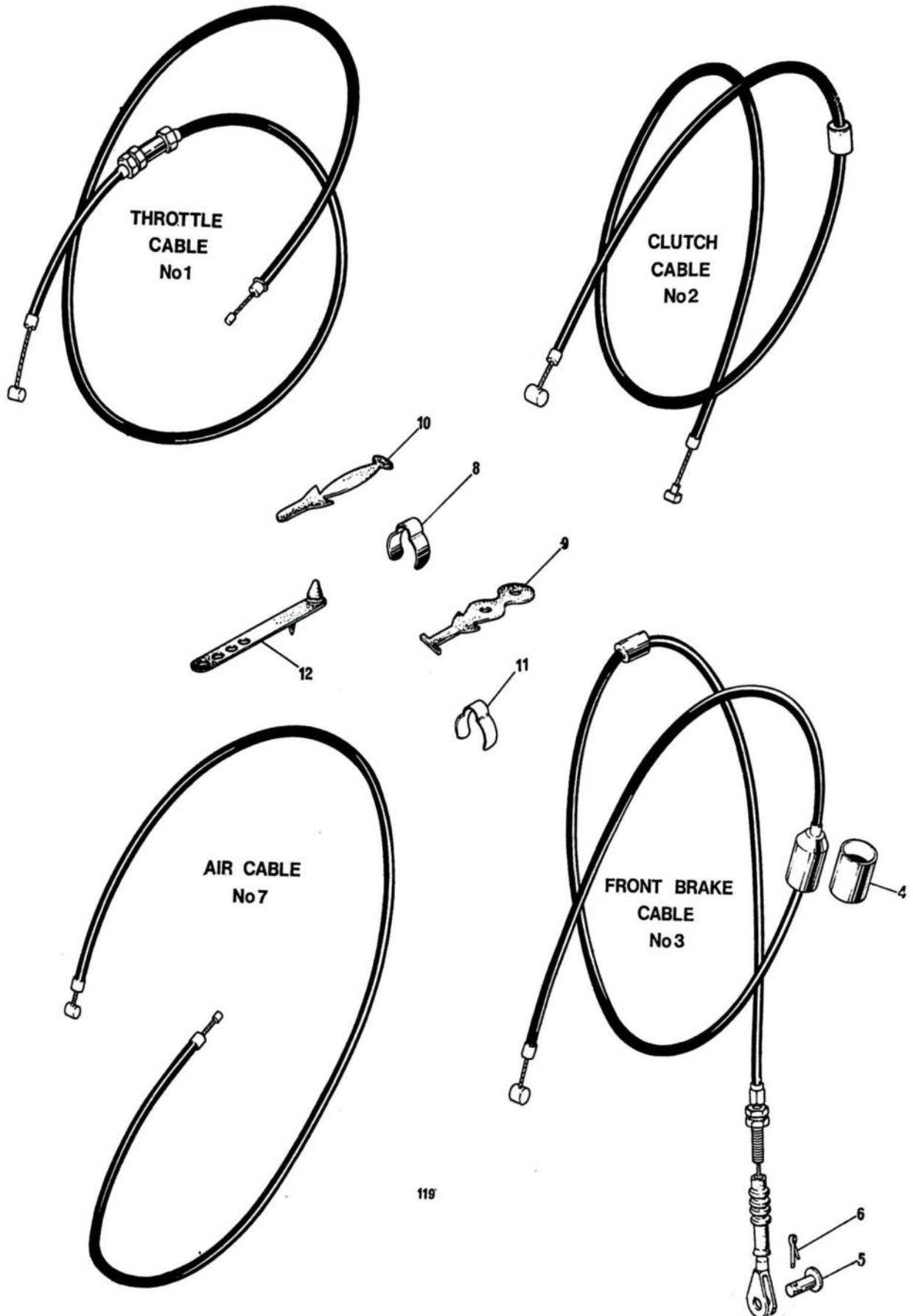

Fig. 21. CONTROL CABLES

Ref. No. Part No. DESCRIPTION QUANTITY

CONTROL CABLES

Ref. No.	Part No.	DESCRIPTION	QUANTITY	REMARKS
1	60-0746	Throttle cable	1	
2	60-1994	Clutch cable	1	
3	60-4088	Front brake cable	1	
4	60-2086	Cover, stop switch	1	
5	60-4252	Clevis pin	1	
6	—	Split pin ($\frac{1}{16}$ in. x $\frac{3}{8}$ in.)		Reference only
7	60-4190	Air control cable	1	
8	97-4112	Cable clip, handlebar	4	
9	60-0978	Cable clip	6	
10	60-4258	Cable clip	12	
11	97-4297	Cable clip	6	
12	60-3105	Cable strap	4	

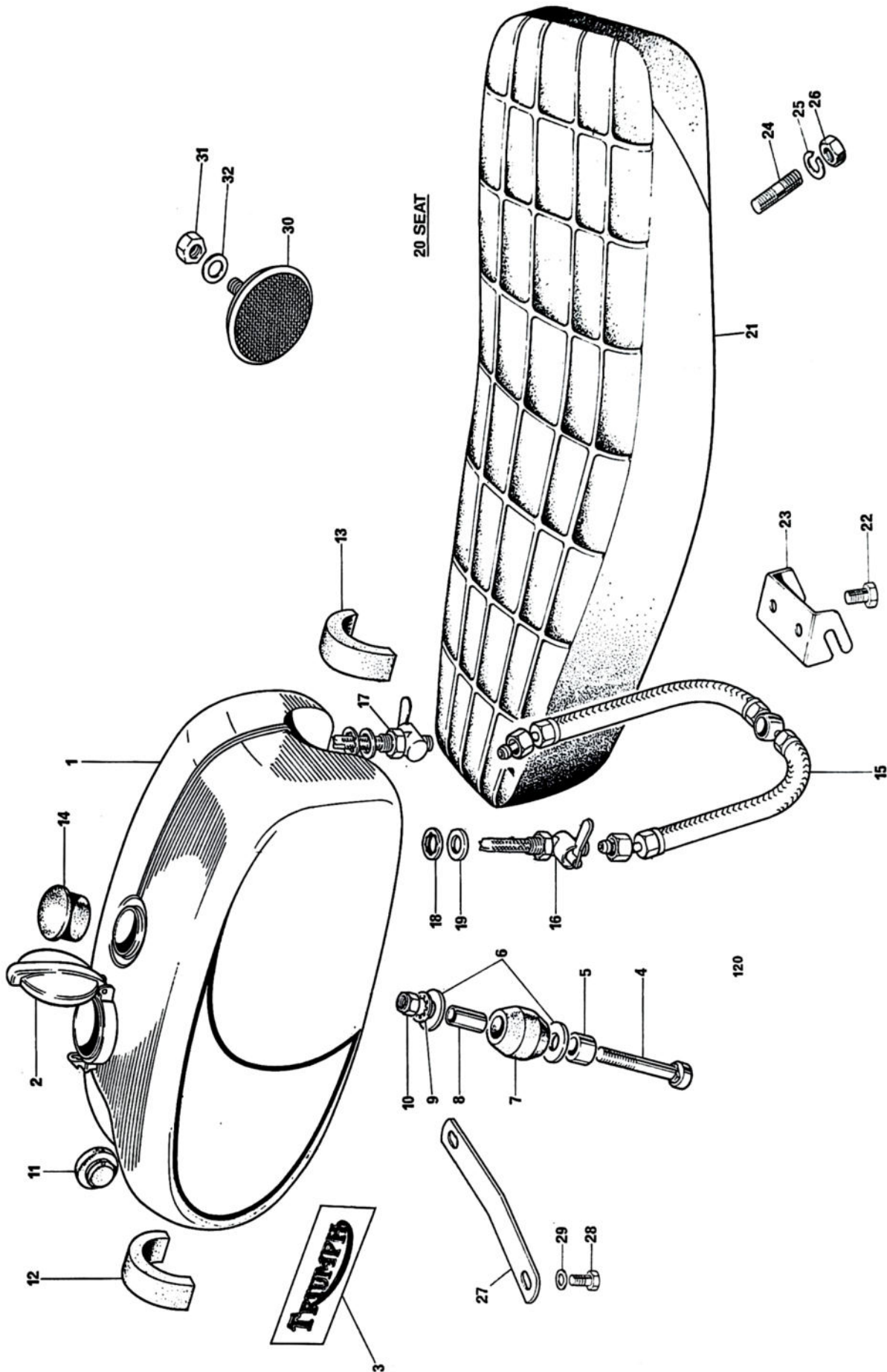

FIG. 22. GAS TANK AND SEAT

Ref. No. Part No. DESCRIPTION QUANTITY REMARKS

GAS TANK AND SEAT

1	83-5386	Petrol Tank	1	
2	83-5201	Filler cap	1	
3	60-3157	Transfer	2	
4	83-5009	Centre fixing bolt	1	
5	82-7071	Collar	1	
6	82-9065	Washer	2	
7	82-9064	Mounting rubber	1	
8	82-9063	Distance tube	1	
9	70-2287	Serrated washer	1	
10	14-0302	Nut	1	
11	82-9222	Anti-roll rubber	2	
12	83-2980	Mounting rubber—front	1	
13	83-3563	Mounting rubber—rear	1	
14	83-3069	Grommet	1	
15	83-4203	Gas pipe	1	
16	83-2800	Gas tap	1	
17	83-2801	Gas tap—reserve	1	
18	70-7351	Seal	2	
19	83-0002	Washer	2	
20	83-4732	SEAT	1	
21	83-4737	Seat cover	1	
22	14-0103	Bolt	2	} Seat attachment front
23	83-2742	Bracket	1	
24	21-2109	Stud	2	} Seat attachment—rear
25	60-2428	Washer	2	
26	14-0302	Nut	2	
27	83-4722	Tie strap	1	
28	14-6113	Bolt	2	} Tie strap to tank
29	70-2287	Washer	2	
30	57183	Reflector—amber (99-1161)	2	
31	82-4717	Nut	2	
32	60-2391	Washer	2	

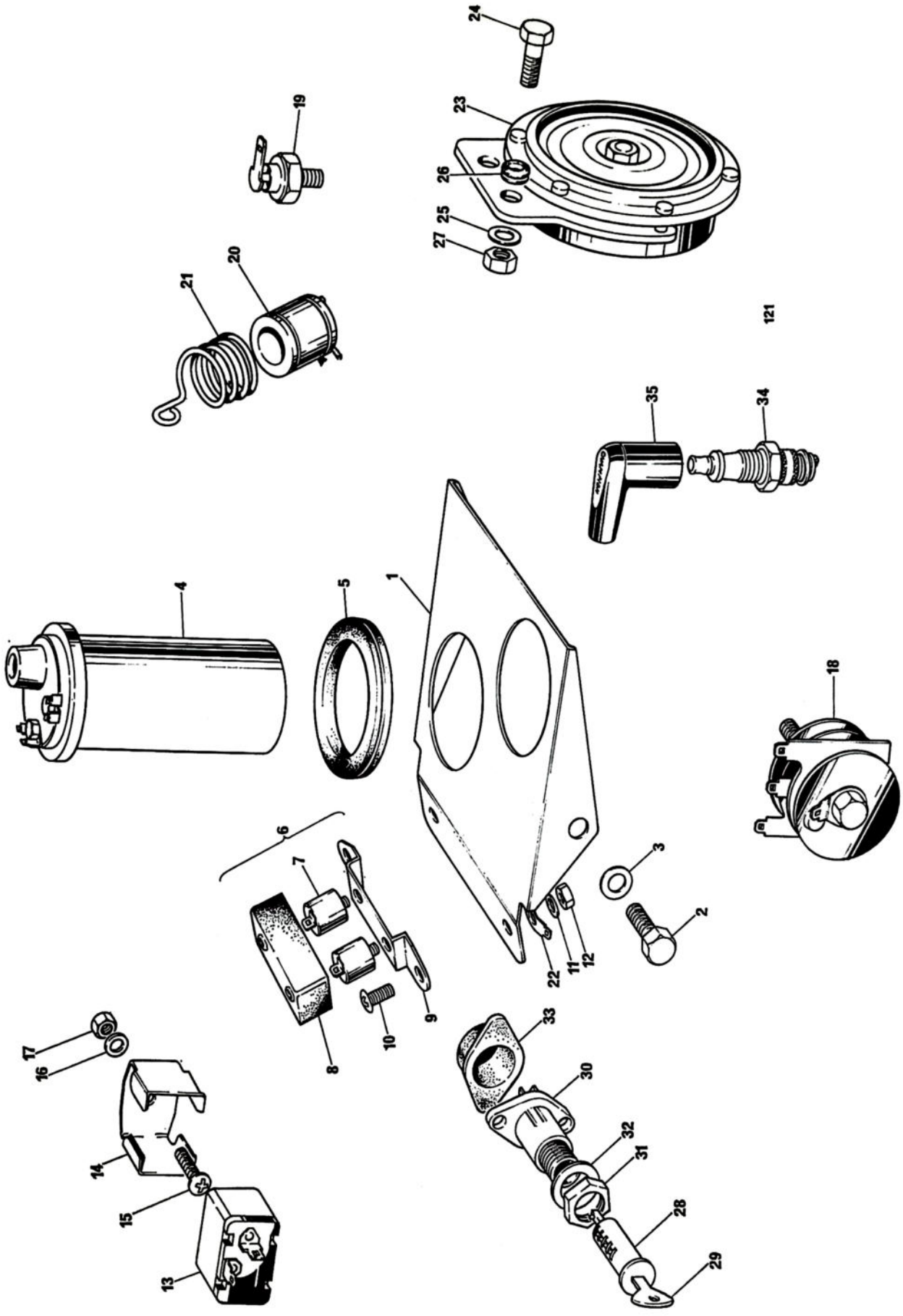

FIG. 23. ELECTRICAL COMPONENTS

Ref. No.	Part No.	DESCRIPTION	QUANTITY	REMARKS
ELECTRICAL COMPONENTS				
1	83-4111	Mounting Platform—Electrical components	1	
2	14-0102	Bolt	2	
3	60-2427	Washer	2	
4	45223	Coil—17-M-12 (60-2206)	2	
5	83-4139	Coil grommet	2	
6	47638	CONDENSER PACK—2CP		Reference only
7	54420128	Condenser (99-1043)	2	
8	54418528	Cover (99-0767)	1	
9	54418526	Base plate (99-1160)	1	
10	21-2079	Screw	2	
11	60-2391	Washer	2	
12	21-0778	Nut	2	
13	35048	Flasher unit—8FL (99-1201)	1	
14	54385091	Clip (99-1204)	1	
15	21-2079	Screw	1	
16	60-2391	Washer	1	
17	21-0778	Nut	1	
18	49072	Rectifier (99-0589)	1	
19	49345	Zener Diode (99-0590)	1	
20	54170009	Electrolytic Capacitor (99-0737)	1	
21	83-5178	Spring	1	
22	54190038	Lucar blade terminal		Reference only
23	70216	Horn—6H (99-1216)	1	
24	83-5045	Screw	2	
25	60-4249	Washer	2	
26	83-5046	Grommet	2	
27	21-0778	Nut	2	
28	82-6981	Ignition lock c/w key	1	
29	60-0622	Key (state serial number)		As required
30	31899	Ignition switch (99-0558)	1	
31	54130041	Nut (99-1000)	1	
32	97-0565	Washer, ignition switch	1	
33	97-2262	Cover, ignition switch	1	
34	N4	Spark plug		Reference only
35	60-0262	Plug cover	2	
Not illus.	54961591	Wiring harness (99-1258)	1	

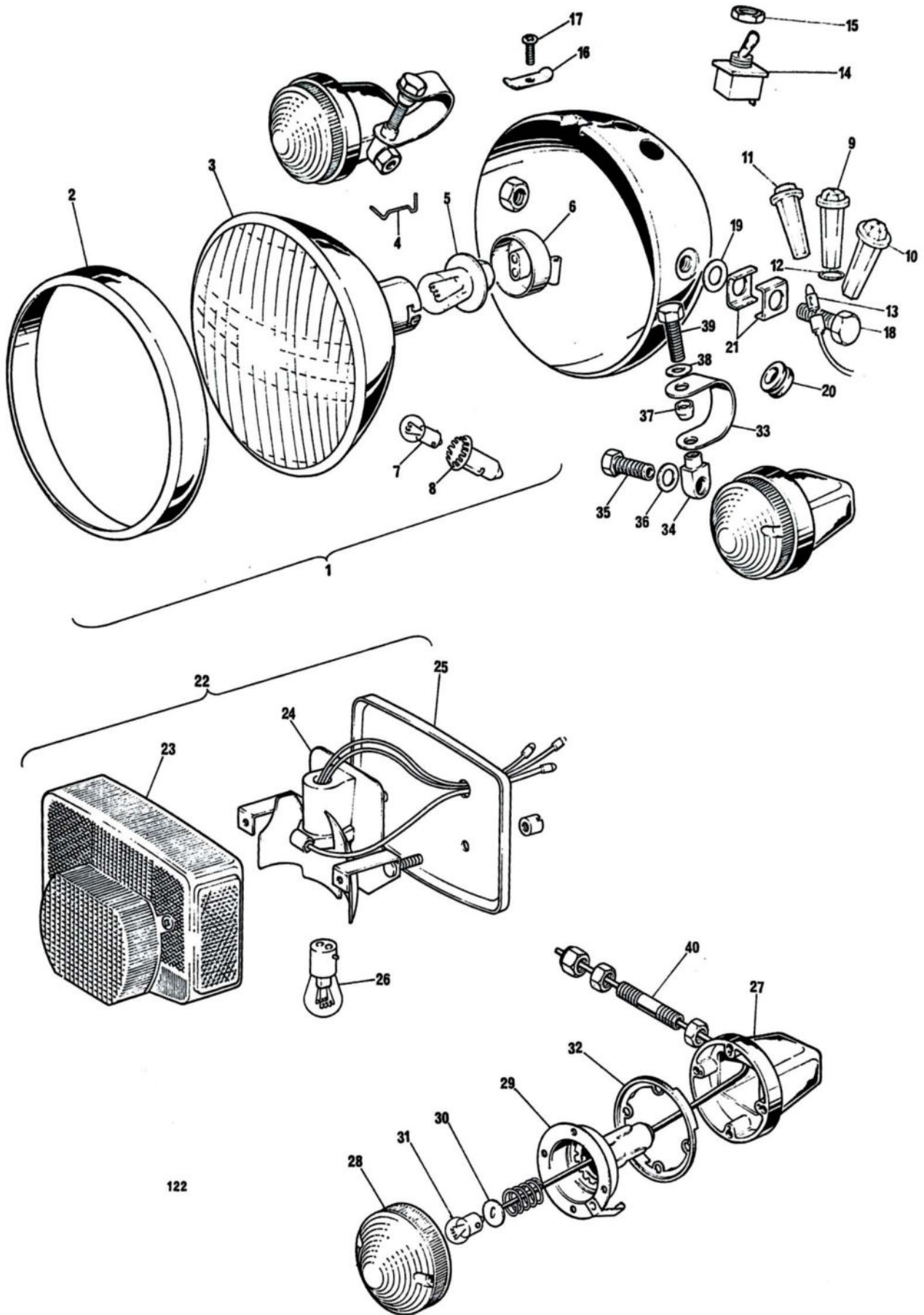

Fig. 24. HEADLAMP, TAIL LAMP AND FLASHERS

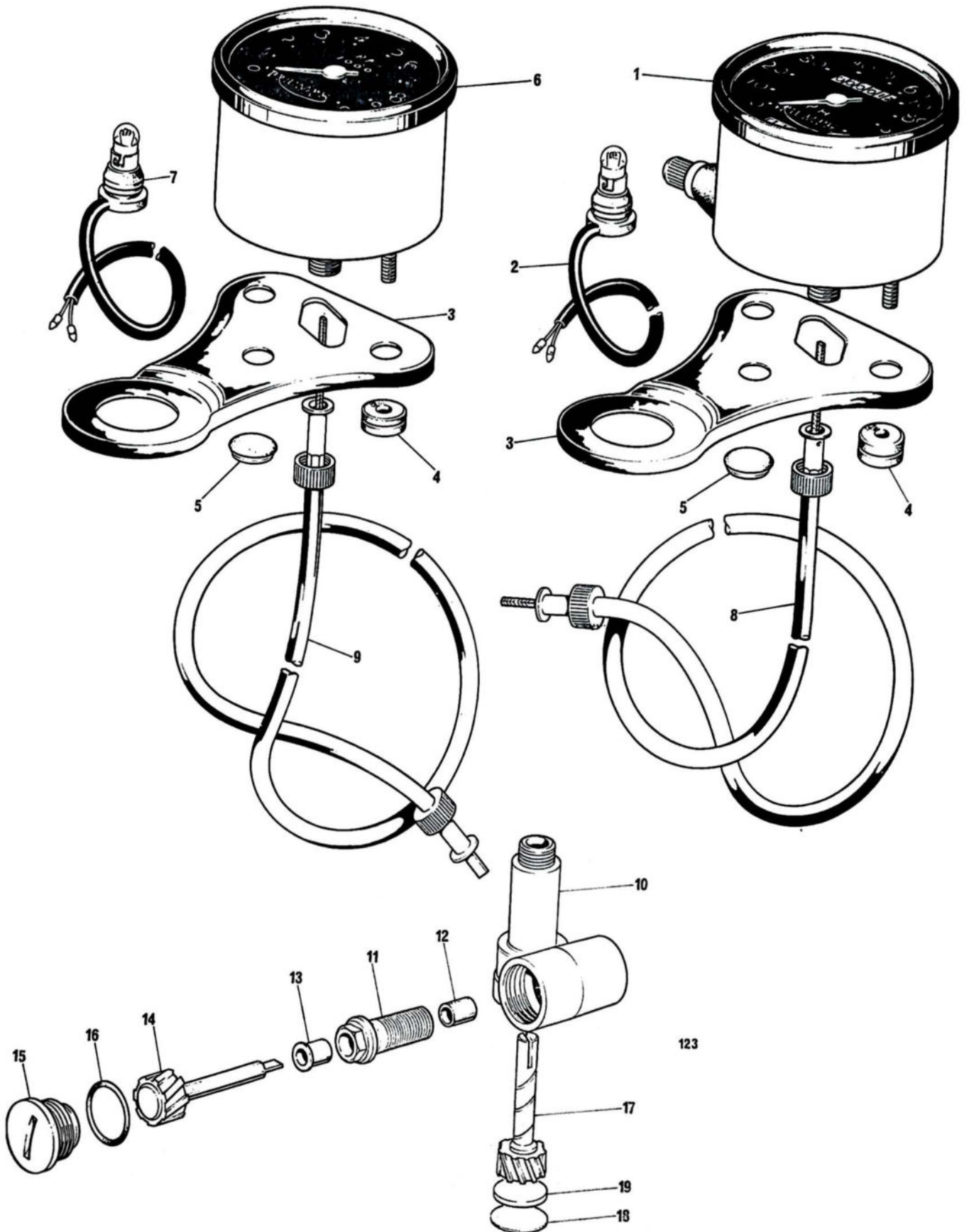

Fig. 25. SPEEDOMETER AND TACHOMETER

Ref. No. Part No. DESCRIPTION QUANTITY REMARKS

SPEEDOMETER AND TACHOMETER

1	NS5338	SPEEDOMETER HEAD MPH. (60-4009)	1	
2	60-4000	Bulbholder	1	
3	97-4529	Mounting bracket	2	
4	60-4106	Rubber grommet	4	
5	60-4137	Blind grommet	2	
6	NS5339	TACHOMETER HEAD (60-4099)	1	
7	60-4000	Bulbholder	1	
8	60-3997	Speedometer cable	1	
9	60-3998	Tachometer cable	1	
10	71-2476	TACHOMETER GEARBOX	1	
11	70-9332	SECURING SCREW	1	
12	70-5156	Bush	Reference only
13	70-5155	Flanged bush	Reference only
14	70-5157	Driving gear	1	
15	71-2480	End cap	1	
16	60-3355	'O' ring	1	
17	71-2653	Driven gear	1	
18	71-2481	Welch washer	1	
19	71-2482	Spacer	1	
Not illus.	70-7351	Sealing washer	1	
Not illus.	60-4314	Transfer, M.P.H. to K.P.H.	Available

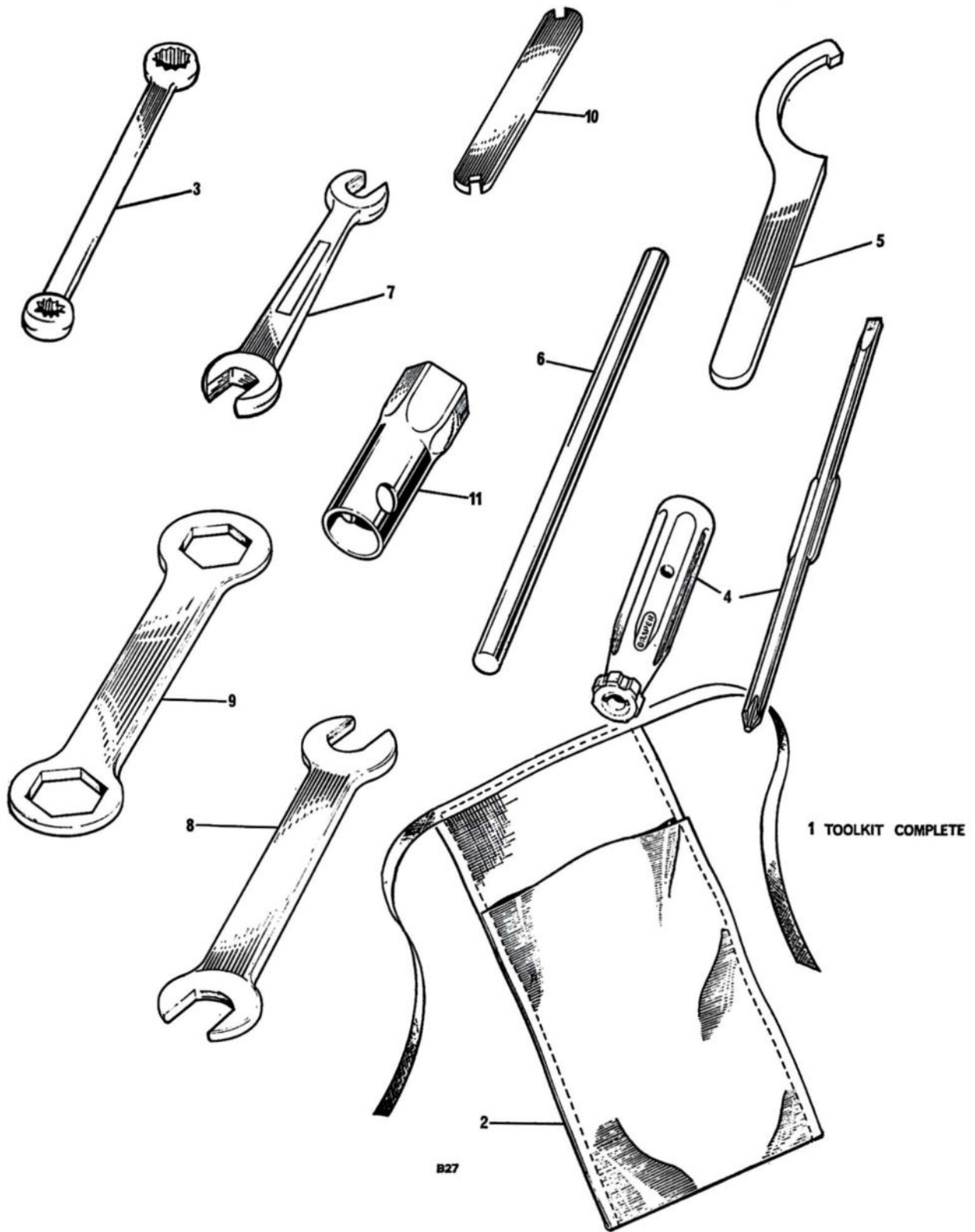

Fig. 26. TOOL KIT

Ref. No.	Part No.	DESCRIPTION	QUANTITY	REMARKS
TOOL KIT				
1	60-4191	TOOL KIT COMPLETE	1	
2	60-0291	Tool roll	1	
3	60-1907	Ring spanner	1	
4	60-0767	Screwdriver	1	
5	60-2184	'C' spanner	1	
6	60-1911	Tommy bar	1	
7	60-2084	Open ended spanner	1	
8	60-0016	Open ended spanner	1	
9	60-3647	Ring spanner	1	
10	60-2185	Tappet spanner	1	
11	60-0087	Plug spanner	1	
Not illus.	60-2599	Licence holder	Available	

STANDARD HARDWARE SPECIFICATION BOLTS

Part No.	Material	Thd. dia.	Length under head	Min. length of thread	Hexagon A.F.
21-1822	Steel	$\frac{5}{16}$ " UNF	$\frac{1}{2}$ "	$\frac{27}{64}$ "	0.500"
21-1910	"	$\frac{3}{8}$ " UNF	$\frac{13}{16}$ "	$\frac{13}{16}$ "	0.565"
21-1919	"	$\frac{5}{16}$ " UNC	$1\frac{5}{8}$ "	$\frac{7}{8}$ "	0.500"
21-2010	"	$\frac{1}{4}$ " UNF	$\frac{13}{16}$ "	$\frac{3}{8}$ "	0.375"
14-0101	"	$\frac{1}{4}$ " UNF	$\frac{1}{2}$ "		0.438"
14-0102	"	$\frac{1}{4}$ " UNF	$\frac{5}{8}$ "		0.438"
14-0103	"	$\frac{1}{4}$ " UNF	$\frac{3}{4}$ "		0.438"
14-0113	"	$\frac{5}{16}$ " UNF	$\frac{5}{8}$ "		0.500"
14-0114	"	$\frac{5}{16}$ " UNF	$\frac{3}{4}$ "		0.500"
14-0115	"	$\frac{5}{16}$ " UNF	$\frac{7}{8}$ "		0.500"
14-0128	"	$\frac{3}{8}$ " UNF	1"		0.563"
14-0208	"	$\frac{1}{4}$ " UNF	$2\frac{1}{4}$ "	$\frac{3}{4}$ "	0.438"
14-0216	"	$\frac{5}{16}$ " UNF	$1\frac{1}{8}$ "	$\frac{7}{8}$ "	0.500"
14-0217	"	$\frac{5}{16}$ " UNF	$1\frac{1}{4}$ "	$\frac{7}{8}$ "	0.500"
14-0219	"	$\frac{5}{16}$ " UNF	$1\frac{1}{2}$ "	$\frac{7}{8}$ "	0.500"
14-0220	"	$\frac{5}{16}$ " UNF	$1\frac{3}{4}$ "	$\frac{7}{8}$ "	0.500"
14-0225	"	$\frac{5}{16}$ " UNF	3"	$\frac{7}{8}$ "	0.500"
14-0228	"	$\frac{5}{16}$ " UNF	4"	$\frac{7}{8}$ "	0.500"
14-0234	"	$\frac{3}{8}$ " UNF	$1\frac{3}{4}$ "	1"	0.563"
14-0236	"	$\frac{3}{8}$ " UNF	$2\frac{1}{4}$ "	1"	0.563"
14-0239	"	$\frac{3}{8}$ " UNF	3"	1"	0.563"
14-0240	"	$\frac{3}{8}$ " UNF	$3\frac{1}{4}$ "	1"	0.563"
14-0242	"	$\frac{3}{8}$ " UNF	4"	1"	0.563"
14-0251	"	$\frac{7}{16}$ " UNF	$2\frac{3}{4}$ "	$1\frac{1}{4}$ "	0.625"
14-6102	"	$\frac{1}{4}$ " UNC	$\frac{5}{8}$ "		0.438"
14-6115	"	$\frac{5}{16}$ " UNC	$\frac{7}{8}$ "		0.500"

NUTS

Part No.	Material	Thd. dia.	Hexagon A.F.	Thickness	Remarks
21-0778	Steel	No. 10 UNF	0.375"	0.225"	Clevelop
21-1852	"	$\frac{5}{16}$ " UNF	0.437"	0.330"	Philidas
21-1906	"	$\frac{1}{4}$ " UNF	0.348"	0.188"	Plain
21-1908	"	$\frac{5}{16}$ " UNF	0.438"	0.313"	Plain
21-1914	"	$\frac{3}{4}$ " UNEF	1.125"	0.250"	Plain
21-2012	"	$\frac{7}{8}$ " UNEF	1.313"	0.438"	Plain
21-2013	"	$\frac{3}{4}$ " UNEF	1.313"	0.313"	Plain
21-2014	"	$\frac{3}{4}$ " UNEF	1.313"	0.438"	Plain
14-0301	"	$\frac{1}{4}$ " UNF	0.438"	0.224"	Plain
14-0302	"	$\frac{5}{16}$ " UNF	0.500"	0.271"	Plain
14-0401	"	$\frac{1}{4}$ " UNF	0.438"	0.161"	Lock
14-0402	"	$\frac{5}{16}$ " UNF	0.500"	0.192"	Lock
14-0403	"	$\frac{3}{8}$ " UNF	0.563"	0.224"	Lock
14-0701	"	$\frac{1}{4}$ " UNF	0.438"	0.203"	Philidas
14-0702	"	$\frac{5}{16}$ " UNF	0.500"	0.246"	Philidas
14-0703	"	$\frac{3}{8}$ " UNF	0.563"	0.296"	Philidas
14-1201	"	$\frac{1}{4}$ " UNF	0.438"	0.285"	Stiffnut
14-1202	"	$\frac{5}{16}$ " UNF	0.500"	0.335"	Stiffnut
14-1301	"	$\frac{1}{4}$ " UNF	0.438"	0.245"	Stiffnut
14-1302	"	$\frac{5}{16}$ " UNF	0.500"	0.290"	Stiffnut
14-1303	"	$\frac{3}{8}$ " UNF	0.563"	0.320"	Stiffnut
14-1304	"	$\frac{7}{16}$ " UNF	0.688"	0.375"	Stiffnut
14-1305	"	$\frac{1}{2}$ " UNF	0.750"	0.435"	Stiffnut
14-1902	"	$\frac{5}{16}$ " UNF	0.500"	0.361"	Nyloc
14-1903	"	$\frac{3}{8}$ " UNF	0.563"	0.375"	Nyloc

SCREWS

Part No.	Type of head	Material	Thd. dia.	Length under head	Type of drive
21-1916	Cheese head	Steel	$\frac{1}{4}$ " UNC	$1\frac{1}{8}$ "	Cross recess
21-1917	Cheese head	"	$\frac{1}{4}$ " UNC	$2\frac{5}{8}$ "	Cross recess
21-1918	Cheese head	"	$\frac{1}{4}$ " UNC	$2\frac{3}{8}$ "	Cross recess
21-1920	Hex. head	"	$\frac{1}{4}$ " UNC	$2\frac{1}{64}$ "	
21-1929	Countersunk (82°)	"	$\frac{1}{4}$ " UNC	$1\frac{7}{32}$ "	Slot
21-2079	Cheese head	"	No. 10 UNF	$\frac{1}{2}$ "	Pozidrive
14-0604	Cheese head	"	$\frac{1}{4}$ " UNF	$\frac{1}{2}$ "	Cross recess
14-6505	Countersunk (82°)	"	$\frac{1}{4}$ " UNC	$\frac{7}{8}$ "	Cross recess
14-6607	Cheese head	"	$\frac{1}{4}$ " UNC	$\frac{7}{8}$ "	Cross recess
14-6608	Cheese head	"	$\frac{1}{4}$ " UNC	1"	Cross recess
14-6609	Cheese head	"	$\frac{1}{4}$ " UNC	$1\frac{1}{4}$ "	Cross recess
14-7019	Socket head	"	$\frac{5}{16}$ " UNC	$\frac{7}{8}$ "	Hex. socket
14-7024	Socket head	"	$\frac{5}{16}$ " UNC	2"	Hex. socket

WASHERS—PLAIN

Part No.	Material	i/dia.	o/dia.	Thickness
60-4245	Steel	0.273"	0.563"	0.048"
60-4246	Steel	0.398"	0.750"	0.063"
60-4247	Steel	0.336"	0.625"	0.063"
37-2027	Steel	0.531"	1.031"	0.092"
60-4248	Steel	0.266"	0.469"	0.064"

WASHERS—SPRING

Part No.	Material	i/dia.	o/dia.	o/a height	Thickness
60-4259	Spring Steel	$\frac{3}{8}$ " clearance	$\frac{19}{32}$ "	$\frac{7}{32}$ "	0.104"
60-4250	" "	$\frac{1}{4}$ " clearance	$\frac{13}{32}$ "	$\frac{3}{16}$ "	0.064"
60-3541	" "	$\frac{17}{32}$ "	$\frac{7}{8}$ "	$\frac{3}{32}$ "	0.040**
21-0648	" "	$\frac{5}{16}$ " clearance	$\frac{1}{2}$ "	$\frac{5}{32}$ "	0.080"

** Double coil.