

TRIUMPH
Twenty one

REPLACEMENT PARTS

CATALOGUE NO. 1

From Engine No. 21 - H1

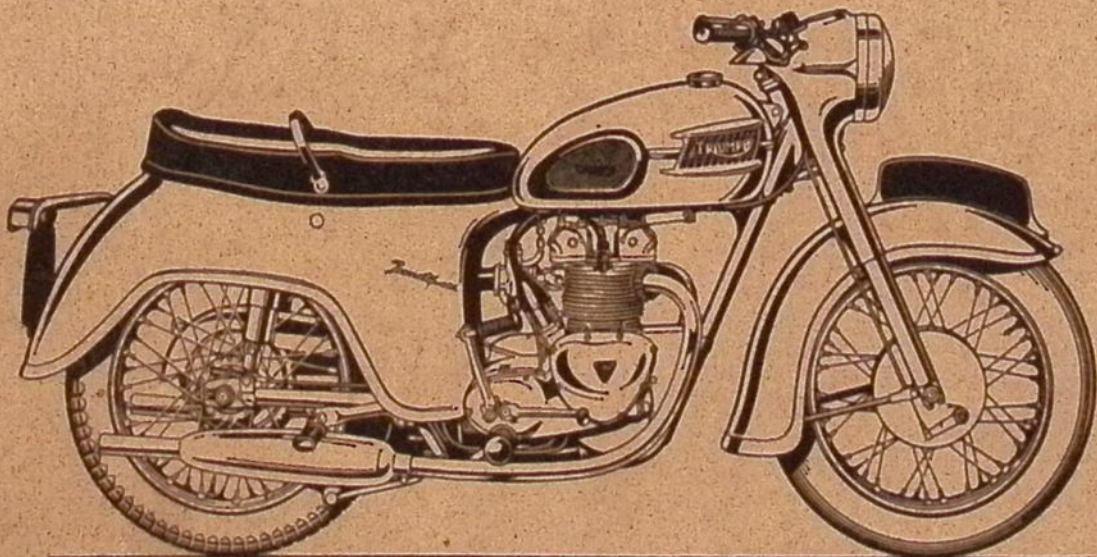

REPLACEMENT PARTS

for

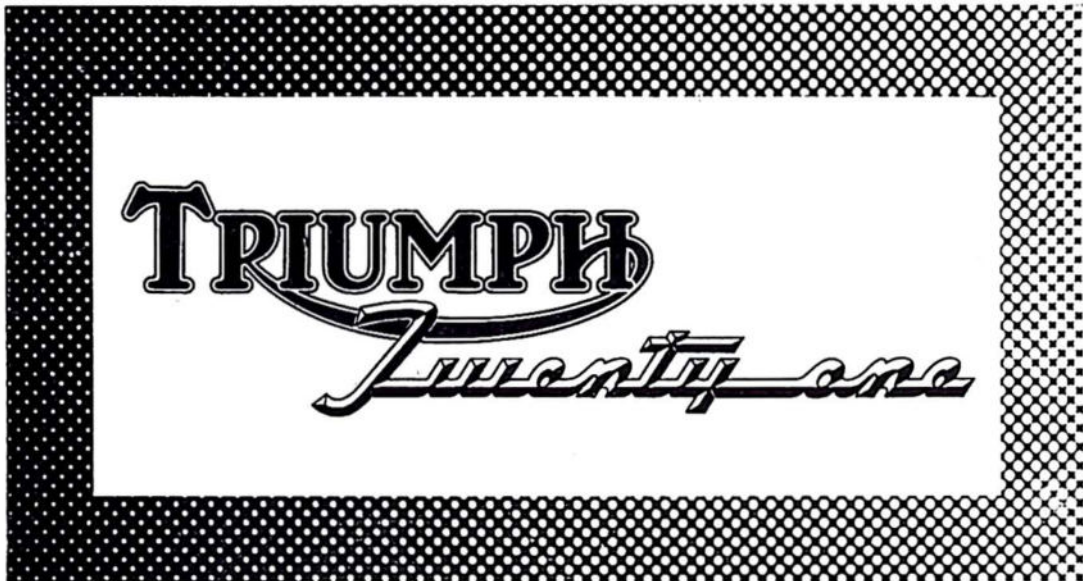

TRIUMPH ENGINEERING COMPANY LIMITED
MERIDEN WORKS · ALLESLEY · COVENTRY · ENGLAND
TELEPHONE MERIDEN 331 TELEGRAMS "TRUSTY COVENTRY"

PREFACE

BEFORE ordering parts for your machine, please read very carefully the instructions contained in the next paragraph. In a large number of cases, the information given in orders is not sufficient to enable us to identify customers' requirements with certainty. Delay is frequently occasioned by our having to refer the order back for further particulars before we can supply.

HOW TO ORDER. Every part is indicated by number, and this should be quoted together with the description. In order to assist customers, dimensions have been given in many cases where parts are similar. Parts where possible have been listed in order of assembly and a number of the illustrations show the assembly order also. With these aids there should be no difficulty in identifying the parts you require. Always head your order with the engine number, stamped on the drive side of the crank case underneath the cylinder flange, together with the prefix letters. Use a separate sheet for your order if you are sending a letter as well.

SPECIMEN ORDER

25/6/57

To Triumph Engineering Co. Ltd.,
Spares Department,
Meriden Works,
Allesley,
Coventry.

Engine No. 21-H1457

Please supply :—

1 - CP.164/20 - Piston Assy. + .020"
1 - E3208 - Guide, inlet valve

*Send C.O.D.

Wm. Smith,
1a, Ewell Avenue,
Ewell, Surrey.

**For terms of business see page 3.*

TELEGRAPHIC ORDERS. Orders by telegram should be addressed to "Trusty 60221 Coventry." They are then telephoned to us, which prevents delay in delivery. It is only necessary to quote part numbers in telegraphic orders, the description can be omitted.

PATTERNS AND PARTS FOR REPAIR. It is not necessary to send patterns if the part number is quoted. The sending of patterns often delays the order as parcel post or rail takes longer than letter post.

Parts sent to Coventry for repair, replacement or as patterns should bear the sender's name and address and clear instructions should accompany the parts. All parts must be forwarded carriage paid and care should be taken to ensure that all remittances are sent separately and not enclosed with the parts. Fragile units such as cylinders, etc., should always be boxed to avoid damage in transit. Complete machines should have all fitments such as horns, driving mirrors, tools, etc., removed by the sender before despatch, as it is impossible for us to accept responsibility in the event of loss in transit. We are always please to give estimates for overhauling and repairs, but should an estimate not be accepted, a charge will be made covering cost of dismantling and re-assembling, if carried out.

Communications relating to Parts should be addressed to the SPARES MANAGER and for repairs, guarantee claims and technical advice to the SERVICE MANAGER, Triumph Engineering Co. Ltd., Meriden Works, Allesley, Coventry. In order to facilitate quick reference, the quoting of any number, invoice number or reference from previous communications is of essential importance. **Accessories not of our manufacture should be sent direct to the actual makers, whose names and addresses appear on Page 51.**

WHERE TO OBTAIN. Triumph Spare Parts may be obtained from any Triumph Dealer, and we recommend our customers to place their orders with the Triumph Dealer in their district, as we do not normally supply direct. When parts not usually asked for are required, and for which the Dealer may have to wire or obtain specially, the postage or carriage incurred becomes payable.

We are not able to supply Transfers as originally affixed to Triumph Motor Cycles, but we are at all times willing to supply a transfer denoting that the machine is of genuine Triumph manufacture, provided the Frame and Engine prefix letters and numbers are quoted.

Customers are warned against the risk incurred by purchasing parts that are not of genuine Triumph manufacture. This risk is eliminated if parts are ordered as instructed, either from our recognised Dealers, or direct from the Spares Department, Meriden Works, Allesley, Coventry.

TERMS OF BUSINESS

THE most convenient method of paying for Spare Parts is by the C.O.D. system. By this method you pay the postman for the goods when he delivers them to you. As the minimum C.O.D. collection fee is 1/2, only goods to the value of 2/- and over can be sent by this system. We do not despatch goods by rail C.O.D.

Where goods are not sent C.O.D., cash must accompany the order. All remittances should be made payable to the Triumph Engineering Co. Ltd., and crossed "Barclay's Bank Ltd." if in the form of Postal Order or cheque. Letters containing currency notes must be registered.

Should a remittance be forwarded by telegraphic money order, the name and address of the sender must be inserted in the space provided on the Post Office requisition form for a private message from remitter to payee. Unless this is complied with the Post Office omit such information from the telegram and we are not then in a position to trace the sender.

Postage, carriage and packing is charged at 5% on the value of the goods, minimum charge 1/-. Packing boxes, cases, crates, etc., are charged for at cost and are returnable.

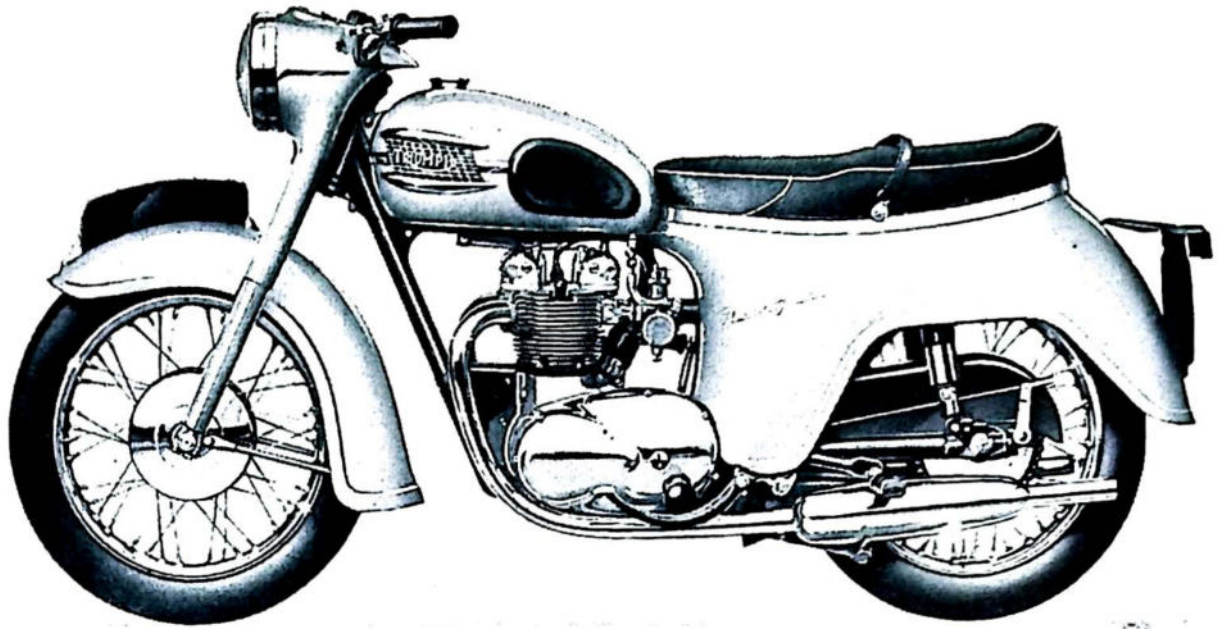

THE

TRIUMPH

MODEL "TWENTY-ONE"

350 c.c. (21 cu. ins.) O.H.V. TWIN

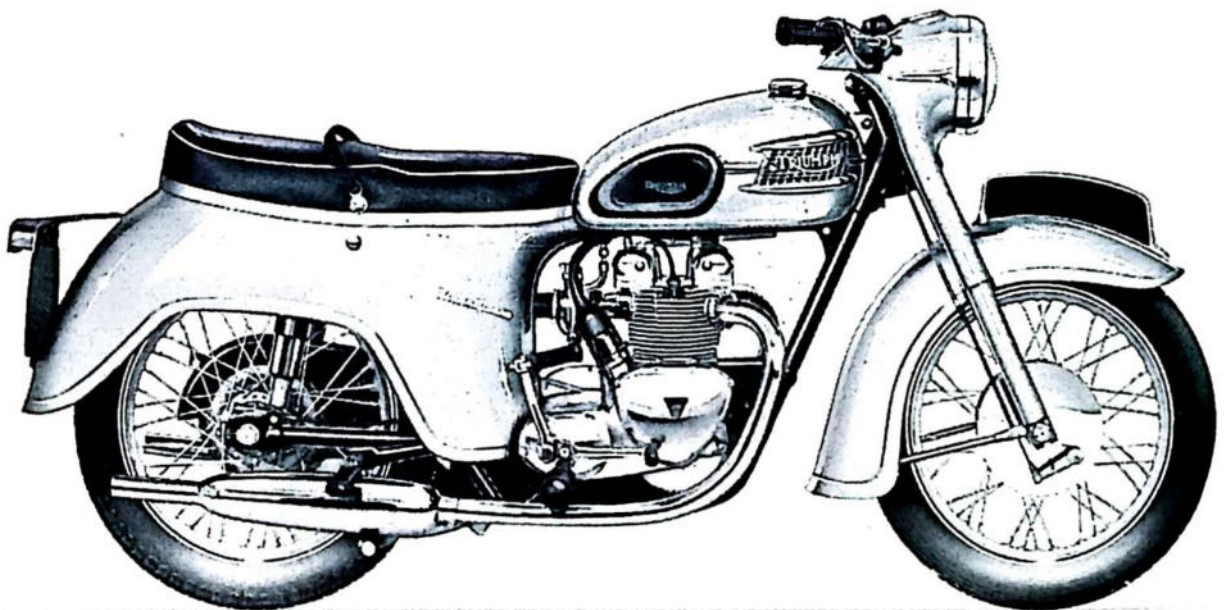

CARTON PACK — GROUP I

CARTON PACK COMPONENT LIST—GROUP I

The following sub-assemblies are supplied in carton packs under the C.P. part number stated. The contents of these carton packs are preserved and will not deteriorate under adverse conditions.

Part No.		Description and Contents						
Brake Lining								
CP38/DMI	...	2	NW243/DMI	Lining, brake
		16	W129	Rivet
Crankcase Bearings								
CPI69	...	1	E3790	Bearing, R.H. main
		1	E3835	Bearing, L.H. main (Ball Journal)
Fork Service Pack								
CPI68	...	2	H441	Bearing, upper
		2	H443	Bearing, lower
		4	H430	Washer, fibre
		2	H1062	Washer, aluminium
		2	H420	Washer, felt
		2	H1168	Seal, oil
Piston Assemblies								
CPI64	...	1	E3689	Piston, standard
		1	E3691	Ring, top (plain)
		1	E3690	Ring, middle (taper)
		1	E3692	Ring, bottom (scraper)
		1	E1750	Pin, gudgeon
		2	E1767	Circlip
CPI64/10	...	1	E3689/10	Piston, + .010"
		1	E3691/10	Ring, top (plain)
		1	E3690/10	Ring, middle (taper)
		1	E3692/10	Ring, bottom (scraper)
		1	E1750	Pin, gudgeon
		2	E1767	Circlip
CPI64/20	...	1	E3689/20	Piston, + .020"
		1	E3691/20	Ring, top (plain)
		1	E3690/20	Ring, middle (taper)
		1	E3692/20	Ring bottom (scraper)
		1	E1750	Pin, gudgeon
		2	E1767	Circlip

GROUP I — CARTON PACK

Part No.		Description and Contents						
Piston Assemblies								
CPI64/40	...	1	E3689/40	Piston, + .040"
		1	E3691/40	Ring, top (plain)
		1	E3690/40	Ring, middle (taper)
		1	E3692/40	Ring, bottom (scraper)
		1	E1750	Pin, gudgeon
		2	E1767	Circlip
Piston Rings								
CPI65	...	2	E3691	Ring, top (plain)
		2	E3690	Ring, middle (taper)
		2	E3692	Ring, bottom (scraper)
CPI65/10	...	2	E3691/10	Ring, top (plain)
		2	E3690/10	Ring, middle (taper)
		2	E3692/10	Ring, bottom (scraper)
CPI65/20	...	2	E3691/20	Ring, top (plain)
		2	E3690/20	Ring, middle (taper)
		2	E3692/20	Ring, bottom (scraper)
CPI65/40	...	2	E3691/40	Ring, top (plain)
		2	E3690/40	Ring, middle (taper)
		2	E3692/40	Ring, bottom (scraper)
Steering Races								
CPI67	...	1	H1110	Cone
		1	H1140	Cone and dust cover
		2	H1130	Cup
		48	S70-4	Balls
Valves								
CPI66	...	2	E3738	Valve, inlet
		2	E3739	Valve, exhaust
Valve Guides								
CPI70	...	4	E3208	Guide, valve inlet and exhaust
		4	E3209	Circlip, valve guide
Valve Springs								
CPI71	...	4	E3741	Spring, valve outer
		4	E3942	Spring, valve inner

PLEASE NOTE

THROUGHOUT THIS LIST, ASSEMBLIES ARE PRINTED IN CAPITALS AND THE COMPONENTS INCLUDED IN THAT ASSEMBLY ARE INDENTED IN THE DESCRIPTION COLUMN, REVERTING TO THE ORIGINAL ALIGNMENT WHEN THE ASSEMBLY IS COMPLETE. TO ORDER THE COMPLETE ASSEMBLY IT IS NECESSARY ONLY TO QUOTE THE ASSEMBLY NUMBER. ANY COMPONENT PARTS LISTED MAY ALSO BE OBTAINED SEPARATELY, IF REQUIRED.

GROUP 2—ENGINE

REPLACEMENT PARTS

REF. No.	PART No.	DESCRIPTION	QUANTITY
ENGINE—GROUP 2			
CYLINDER BLOCK			
1	E3698	Block, cylinder	1
2	E3798	Washer, cylinder base	1
3	E2412	Nut, cylinder base	8
PISTONS			
4	CPI64	PISTON COMPLETE 7.5 : 1 CR Standard	2
5	E3691	Ring (plain)	2
6	E3690	Ring, middle (taper)	2
7	E3692	Ring, (scraper)	2
8	E1750	Pin, gudgeon	2
9	E1767	Circlip	2
For oversizes see Page 5			
CYLINDER HEAD AND VALVE GUIDES			
10	E3879	HEAD, CYLINDER C/W GUIDES	1
11	E3208	Guide, valve	4
12	E3209	Circlip, valve guide	4
13	E3737	Adaptor, exhaust pipe	2
14	E3769	Gasket, cylinder head	1
15	E3793	Bolt, cylinder head, short, $2\frac{3}{16}$ " U.H.	4
16	E3794	Bolt, cylinder head, long, $5\frac{7}{16}$ " U.H.	2
17	E3795	Bolt, cylinder head and torque stay, $5\frac{7}{16}$ " U.H.	2
18	F2184	Washer, head bolts	8
INLET MANIFOLD			
19	E3761	Manifold, inlet	1
20	E2967	Washer, manifold joint	2
21	E3796	Stud, manifold to head, short, $1\frac{1}{2}$ " O.A.	2
22	E3797	Stud, manifold to head, long, 2" O.A.	2
23	S25-13	Washer, manifold nut	4
24	W103	Nut, head manifold stud	4
25	E3880	Stud, carburetter fixing, $1\frac{1}{4}$ " O.A.	2
26	NA43	Washer, carburetter joint	1
27	E3834	Block, insulating	1
28	244/765	"O" ring, carburetter to manifold	1
29	S25-3	Washer, carburetter nut	2
30	SI-51	Nut, carburetter to manifold	2

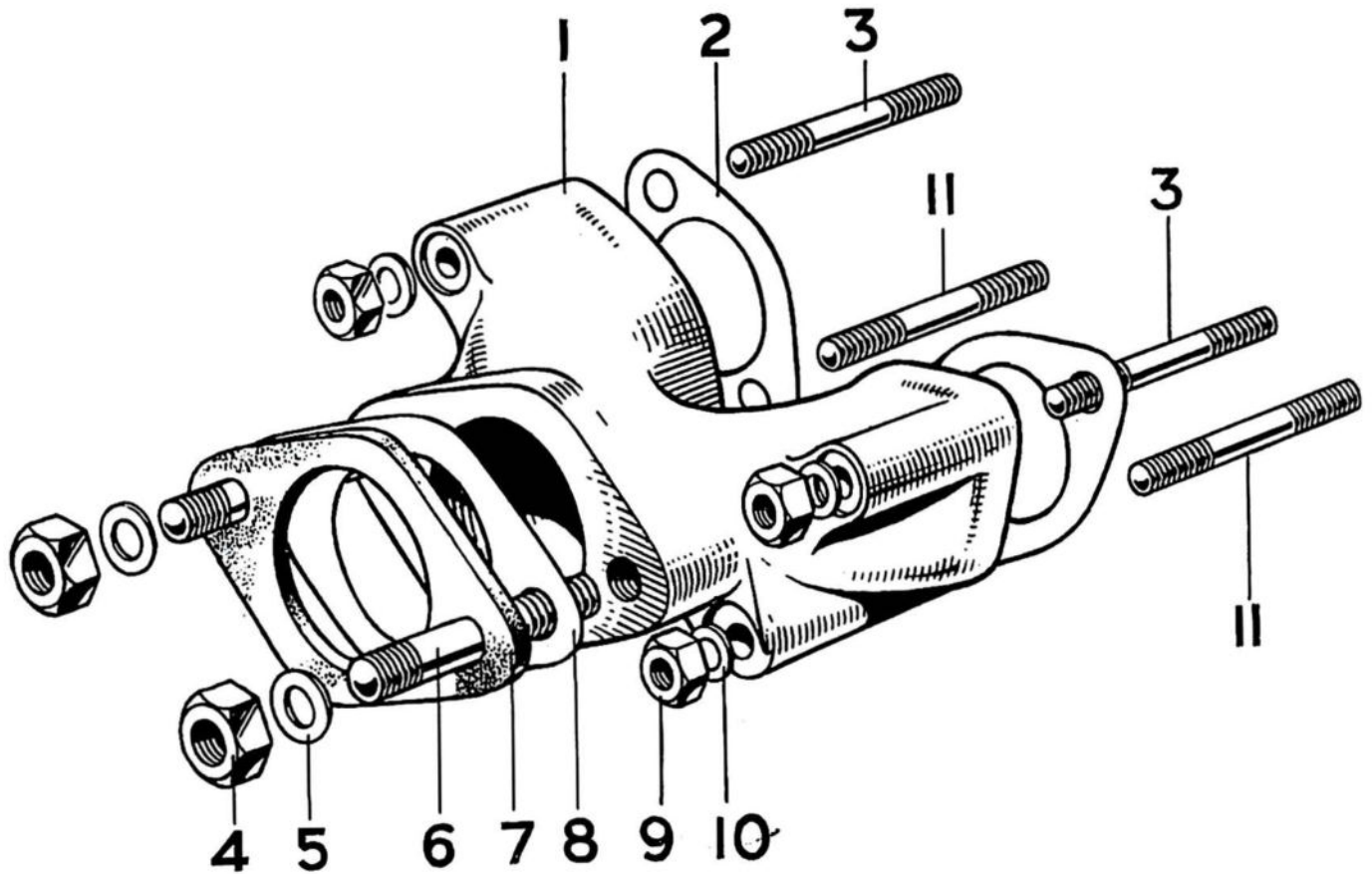

FIG. I INLET MANIFOLD

INDEX TO FIG. I

<i>Illust. No.</i>	<i>Part No.</i>	<i>Page No.</i>	<i>Ref. No.</i>
1	E3761	8	19
2	E2967	8	20
3	E3796	8	21
4	S1-51	8	30
5	S25-3	8	29
6	E3880	8	25
7	E3834	8	27
8	NA43	8	26
9	W103	8	24
10	S25-13	8	23
11	E3797	8	22

GROUP 2 — ENGINE

REF. No.	PART No.	DESCRIPTION	QUANTITY
VALVES AND SPRINGS			
1	E3738	Valve, inlet	2
2	E3739	Valve, exhaust	2
3	E3740	Cup, spring, bottom	4
4	E3741	Spring, valve, outer	4
5	E3942	Spring, valve, inner	4
6	E3742	Collar, spring top	4
7	WE259A	Split cotter, valve	8
ROCKER BOXES AND ROCKER GEAR			
8	E3744	Box, exhaust rocker	1
9	E3745	Box, inlet rocker	1
10	E3743	Washer, rocker box joint	2
11	E3752	Cap, inspection	4
12	E3751	Washer, cap joint	4
13	E3858	Stud, to head, $\frac{15}{16}$ " O.A.	4
14	E3302	Washer, stud nut	4
15	F879	Nut, rocker box stud	4
16	E3668	Screw, to head, $\frac{15}{16}$ " U.H.	4
17	E3857	Washer, screw	4
18	E3748	Spindle, rocker	2
19	E3253	Sealing ring, rocker spindle	2
20	E3749	LEVER, ROCKER, R.H. EXHAUST, L.H. INLET	2
21	E3750	LEVER, ROCKER. L.H. EXHAUST, R.H. INLET	2
22	E3222	Ball pin	4
23	E3223	Adjuster, rocker	4
24	GS662	Nut, adjuster lock	4
25	E3224	Washer, Thackeray (spring)	4
26	E2534	Washer, thrust ($\frac{7}{16}$ " I.D.)	6
27	E1330	Washer, thrust ($\frac{3}{8}$ " I.D.)	2
28	E1335	Washer, copper	2
29	E1435	Nut, rocker spindle	2
ROCKER OIL FEED PIPE			
30	E3809	Bolt, oil feed hollow	2
31	F1880	Washer, copper	6
32	H400	Nut, domed	2
33	E3805	Pipe, rocker oil feed	1

ENGINE — GROUP 2

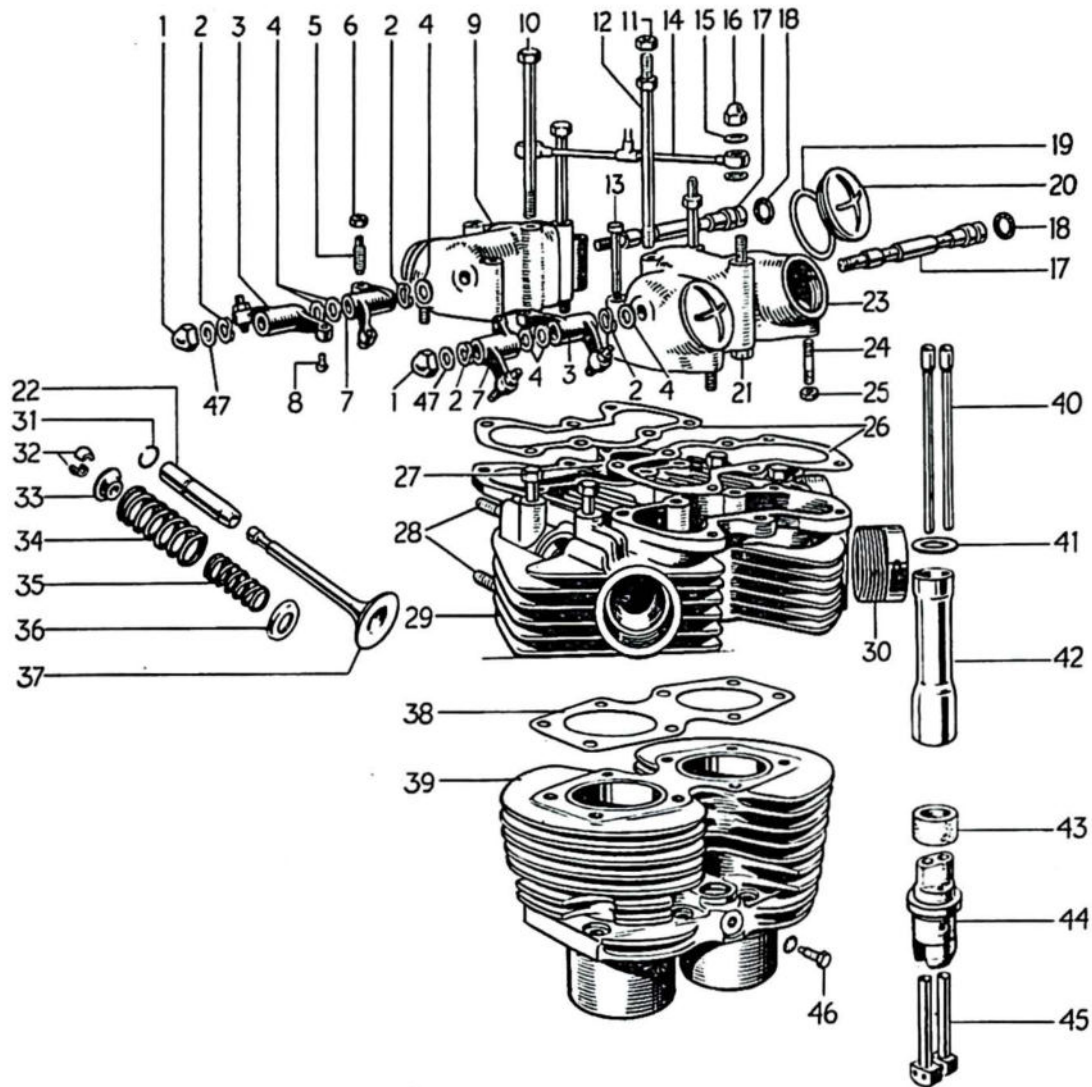

**FIG. 2 CYLINDER BLOCK AND HEAD
INDEX TO FIG. 2**

Illust. No.	Part No.	Page No.	Ref. No.	Illust. No.	Part No.	Page No.	Ref. No.
1	E1435	10	29	25	F879	10	15
2	E3224	10	25	26	E3743	10	10
3	E3750	10	21	27	E3793	8	15
4	E2534	10	26	28	E3796	8	21
5	E3223	10	23		E3797	8	22
6	GS662	10	24	29	E3879	8	10
7	E3749	10	20	30	E3737	8	13
8	E3222	10	22	31	E3209	8	12
9	E3745	10	9	32	WE259A	10	7
10	E3794	8	16	33	E3742	10	6
11	SI-52	26	33	34	E3741	10	4
12	E3795	8	17	35	E3942	10	5
13	E3668	10	16	36	E3740	10	3
14	E3805	10	33	37	E3738	10	1
15	F1880	10	31	38	E3769	8	14
16	H400	10	32	39	E3698	8	1
17	E3748	10	18	40	E3759	16	5
18	E3253	10	19	41	E3547	16	7
19	E3751	10	12	42	E3755	16	6
20	E3752	10	11	43	E3758	16	8
21	E3809	10	30	44	E3736	16	1
22	E3208	8	11	45	E3753	16	4
23	F3744	10	8	46	H200	16	2
24	E3858	10	13	47	E1330	10	27

GROUP 2 — ENGINE

REF. No.	PART No.	DESCRIPTION	QUANTITY
CRANKSHAFT			
1	E3707	FLYWHEEL AND CRANKSHAFT ASSEMBLY	1
2	E3875	Crankshaft assembly	1
3	E3709	Tube, crankshaft oil	1
4	E3710	Plug, crankshaft L.H.	1
5	E3711	Plug, crankshaft R.H.	1
6	E3712	Flywheel	1
7	E2288	Washer, shakeproof	3
8	E3713	Bolt, flywheel to crankshaft	3
CONNECTING RODS			
9	E3702	ROD, CONNECTING	2
10	E1762	Bush, connecting rod small end	2
11	E3705	Bolt, connecting rod to cap	4
12	E2922	Nut, connecting rod bolt	4
13	E3706	Bearing, big end, standard	4
14	E3706/10	Bearing, big end, 0.010" undersize	A
15	E3706/20	Bearing, big end, 0.020" undersize	A
16	E3706/30	Bearing, big end, 0.030" undersize	A
17	E3706/40	Bearing, big end, 0.040" undersize	A
CRANKCASE			
18	E3687/8	CRANKCASE C/W STUDS AND R.H. MAIN BEARING ...	1
19	E3716	Dowel, hollow crankcase halves	1
20	E3717	Stud, oil pipes junction, 1½" O.A.	1
21	E3718	Stud, oil pump, 1⅝" O.A.	2
22	E3820	Stud, cylinder base inner, 1½" O.A.	4
23	E3819	Stud, cylinder base (dowels), 1⅞" O.A.	2
24	E1534A	Dowel, cylinder base	2
25	E3818	Stud, cylinder base, 1⅞" O.A.	2
26	E3859	Screw, at camshaft bosses, ⅜" U.H.	2
27	E3803	Stud, rear, crankcase halves, 3¾" O.A.	2
28	E3804	Stud, bottom front, 3" O.A.	1
29	E3799	Bolt, top rear, 1⅝" U.H.	1
30	S25-3	Washer, studs and bolt	5
31	S1-51	Nut, front and rear studs	4
32	E3719	Pipe, oil scavenge	1
33	E1509	Clip, scavenge pipe	1
34	E1645	Screw, clip, ⅜" U.H.	1
35	E3172	Pin, breather disc	1
36	E3822	Disc, breather	1

ENGINE — GROUP 2

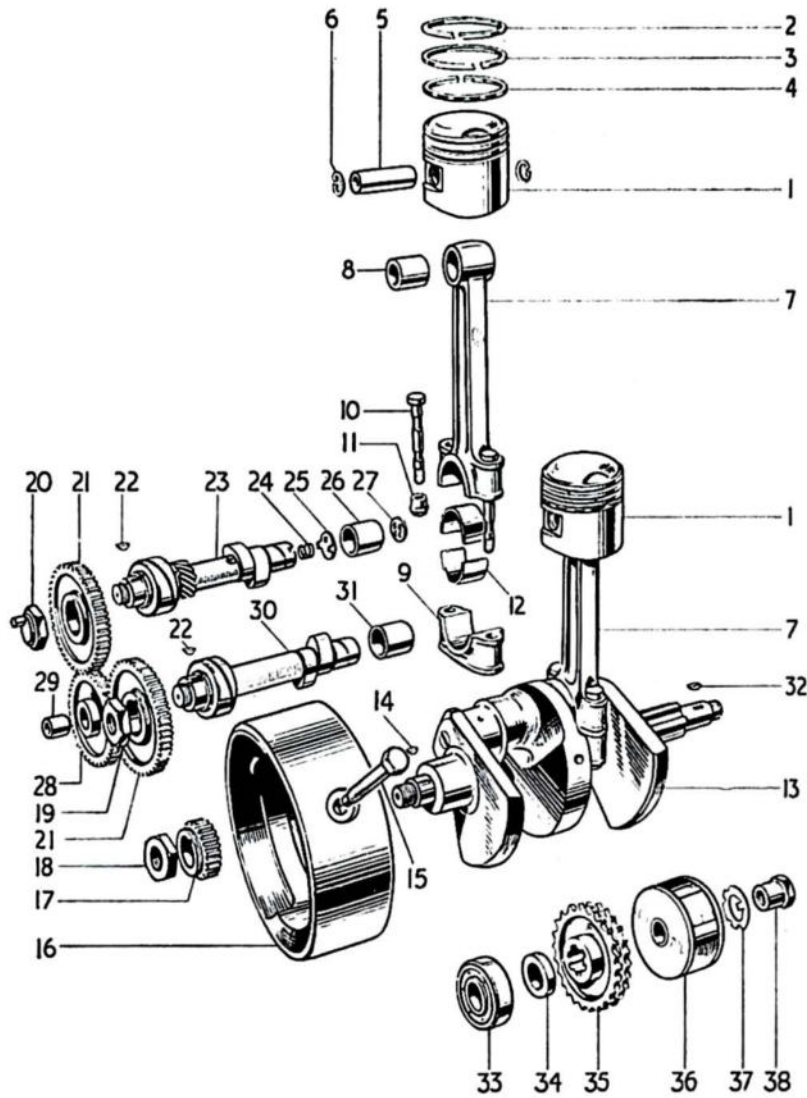

FIG. 3 CRANKSHAFT AND CONNECTING RODS
INDEX TO FIG. 3

Illust. No.	Part No.	Page No.	Ref. No.	Illust. No.	Part No.	Page No.	Ref. No.
1	CP164	8	4	20	E1463	14	31
2	E3691	8	5	21	E1486A	14	29
3	E3690	8	6	22	E1558	14	30
4	E3692	8	7	23	E3838	14	33
5	E1750	8	8	24	E2256	14	22
6	E1767	8	9	25	E2254	14	21
7	E3749	12	9	26	E3824	14	1
8	E1762	12	10	27	E3822	12	36
9	E3702	12	9	28	E2202	14	27
10	E3705	12	11	29	E440	14	28
11	E2922	12	12	30	E3839	14	34
12	E3706	12	13	31	E3823	14	3
13	E3875	12	2	32	E3851	55	2
14	E1580	14	25	33	E3835	14	14
15	E3713	12	8	34	E3733	17	1
16	E3712	12	6	35	E3734	17	2
17	E1771	14	24	36	4235C6	55	1
18	E398	14	26	37	E3852	17	1
19	E1492	14	32	38	E3735	17	4

GROUP 2 — ENGINE

REF. No.	PART No.	DESCRIPTION	QUANTITY
1	E3824	Bush, inlet camshaft (breather)	1
2	E3877	Bush, distributor shaft	1
3	E3823	Bush, exhaust camshaft	1
4	E2724	Pipe, breather (steel)	1
5	E375	Spindle, intermediate timing gear	1
6	E3885	Jet, chain oiler	1
7	E3884	Tube, chain oiler	1
8	T912	Peg, R.H., main bearing	1
9	E3790	Bearing, R.H. main, standard	1
10	E3790/10	Bearing, R.H. main, 0.010" undersize	A
11	E3790/20	Bearing, R.H. main, 0.020" undersize	A
12	E3790/30	Bearing, R.H. main, 0.030" undersize	A
13	E3790/40	Bearing, R.H. main, 0.040" undersize	A
CRANKCASE BEARINGS			
14	E3835	Bearing, L.H. ball journal	1
15	E3876	Seal, oil, L.H. bearing	1
CRANKCASE FITTINGS			
16	E3724	Spring, crankcase filter	1
17	E3722	Filter, crankcase scavenge	1
18	E3723	Washer, filter sealing	1
19	E1564	Cap, crankcase filter	1
20	E1577	Washer, cap joint	1
21	E2254	Valve, rotary breather	1
22	E2256	Spring, breather valve	1
23	E3078	Pipe, breather extension (P.V.C.)	1
TIMING GEARS AND CAMSHAFTS			
24	E1771	Pinion, timing	1
25	E1580	Key, timing pinion	1
26	E398	Nut, timing pinion	1
27	E2202	WHEEL, INTERMEDIATE TIMING	1
28	E440	Bush, intermediate wheel	1
29	E1486A	Pinion, camshaft	2
30	E1558	Key, camshaft pinion	2
31	E1463	Nut, inlet camshaft (oil pump drive)	1
32	E1492	Nut, exhaust camshaft	1
33	E3838	Camshaft, inlet	1
34	E3839	Camshaft, exhaust	1
35	E3727	Plate, camshaft retaining	2
36	E3728	Screw, retaining plate, $\frac{1}{8}$ " U.H.	4
37	E3729	Pinion, distributor drive	1
38	404314	Pin, distributor pinion	1

ENGINE — GROUP 2

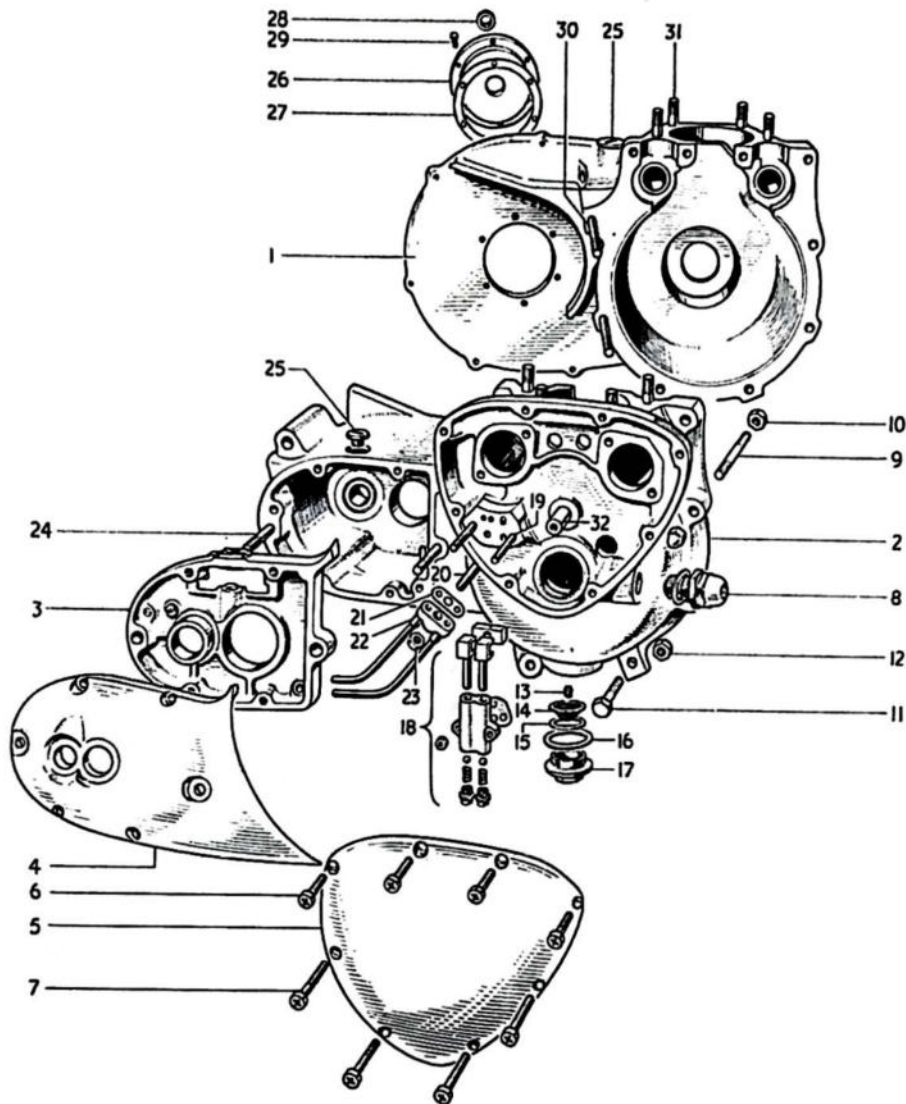

FIG. 4 CRANKCASE AND COVERS

INDEX TO FIG. 4

Illust. No.	Part No.	Page No.	Ref. No.	Illust. No.	Part No.	Page No.	Ref. No.
1	E3687/8	12	18	18	E3878	16	9
2	E3687/8	12	18	19	E3718	12	21
3	T1448	20	9	20	E3717	12	20
4	T1450	20	24	21	E3763	44	17
5	E3693	16	20	22	E3853	44	16
6	E3800	16	23	23	E1310	44	18
7	E3801	16	24	24	T1399	18	22
8	E2795	16	25	25	E732	18	27
9	E3908	26	12	26	E3789	22	26
10	H400	16	14	27	E3832	22	27
11	E3804	12	28	28	E3833	22	28
12	SI-51	12	31	29	E3821	22	29
13	E3724	14	16	30	E3803	12	27
14	E3722	14	17	31	E3820	12	22
15	E3723	14	18		E3819	12	23
16	E1577	14	20		E3818	12	25
17	E1564	14	19	32	E375	14	5

GROUP 2 — ENGINE

REF. No.	PART No.	DESCRIPTION	QUANTITY
TAPPETS AND PUSH RODS			
1	E3736	Block, tappet guide	2
2	H200	Bolt, lock	2
3	E2312	Washer, shakeproof	2
4	E3753	Tappet	4
5	E3759	Rod, valve push	4
6	E3755	Tube, push rod cover	2
7	E3547	Washer, cover tube top	2
8	E3758	Washer, cover tube bottom	2
OIL PUMP			
9	E3878	PUMP, OIL	1
10	E3731	Body, oil pump	1
11	S70-7	Ball, valve	2
12	E403	Spring, valve	2
13	E2360	Plug, body	2
14	GS153	Plunger, feed	1
15	E1476	Plunger, scavenge	1
16	E495	Block, pump drive	1
17	E3730	Washer, pump to crankcase	1
18	E3732	Nut, pump to crankcase	2
19	E3887	Washer, pump nut	2
TIMING COVER			
20	E3693	COVER, TIMING GEARS	1
21	E3874	Plate, patent number	1
22	D208-5	Screw, hammer drive	3
23	E3800	Screw, short, $\frac{7}{8}$ " U.H.	4
24	E3801	Screw, long, $1\frac{1}{8}$ " U.H.	4
OIL PRESSURE RELEASE VALVE			
25	E2795	VALVE, OIL PRESSURE RELEASE	1
26	E2794	Body, release valve	1
27	GS254	Washer, cap to body	1
28	E2790	Cap, release valve	1
29	GS251	Piston, release valve	1
30	E2791	Shaft and button, release valve	1
31	E2792	Nut, shaft	1
32	E2793	Seal, rubber	1
33	E2788	Spring, main	1
34	E2789	Spring, auxiliary	1
35	E1670	Washer, valve to crankcase	1

ENGINE — GROUP 2

REF. No.	PART No.	DESCRIPTION	QUANTITY
ENGINE SPROCKET			
1	E3733	Collar, distance (oil seal)	1
2	E3734	Sprocket, engine, 26T Duplex	1
3	E3852	Washer, tab	1
4	E3735	Nut, sprocket and rotor	1

See Page 55 for rotor and key

PLEASE NOTE

THROUGHOUT THIS LIST, ASSEMBLIES ARE PRINTED IN CAPITALS AND THE COMPONENTS INCLUDED IN THAT ASSEMBLY ARE INDENTED IN THE DESCRIPTION COLUMN, REVERTING TO THE ORIGINAL ALIGNMENT WHEN THE ASSEMBLY IS COMPLETE. TO ORDER THE COMPLETE ASSEMBLY IT IS NECESSARY ONLY TO QUOTE THE ASSEMBLY NUMBER. ANY COMPONENT PARTS LISTED MAY ALSO BE OBTAINED SEPARATELY, IF REQUIRED.

GROUP 3 — GEARBOX

REF. No.	PART No.	DESCRIPTION	QUANTITY
----------	----------	-------------	----------

GEARBOX — GROUP 3

SHAFTS AND GEARS

1	T1403	GEAR, MAINSHAFT HIGH (26T)	1
2	T1405	Bush, mainshaft high gear	1
3	T1406	MAINSHAFT, CLUSTER, THIRD AND LOW GEARS ...	1
4	T1391	Bush, mainshaft for clutch rod	1
5	T1410	Gear, mainshaft second (23T)	1
6	T1411	Distance piece, mainshaft R.H.	1
7	T1479	Layshaft cluster, second and high gears	1
8	T1413	Gear, layshaft third (23T)	1
9	T1414	GEAR, LAYSHAFT LOW (32T)	1
10	T1393	Bush, layshaft low gear	1
11	T1426	Disc, layshaft low gear	1

GEARBOX BEARINGS

12	T665	Bearing, ball journal L.H., high gear	1
13	T1478	Seal, high gear oil	1
14	W680	Circlip, seal and bearing	1
15	T1367	Bush, layshaft L.H.	1
16	T912	Peg, layshaft bush	1
17	T981	Disc, layshaft bush	1
18	T1469	Bearing, ball journal R.H. mainshaft	1
19	T280	Circlip, bearing to inner cover	1
20	T732	Washer, tab	1
21	E2419	Nut, mainshaft R.H.	1

GEARBOX CASING FITTINGS

22	T1399	Stud, gearbox covers, $3\frac{1}{16}$ " O.A.	2
23	T1112	Plug, gearbox drain (with level tube)	1
24	WE170	Washer, drain plug	1
25	T361	Plug, gearbox level	1
26	T1257	Washer, level plug	1
27	E732	Plug, gearbox filler	1
28	NE507	Washer, filler plug	1
29	T1471	Plunger, camplate index	1
30	T373	Spring, camplate plunger	1
31	T1437	Plug, plunger housing	1

GEARBOX — GROUP 3

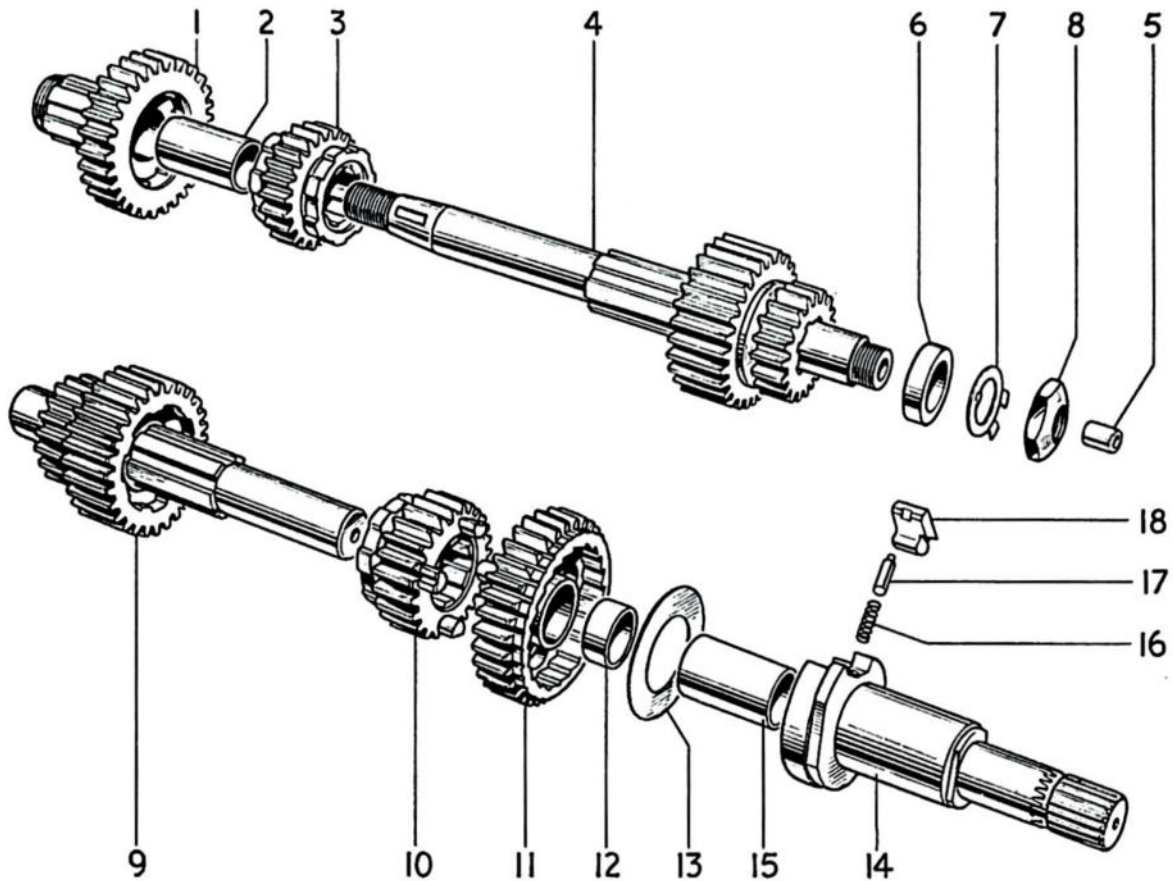

FIG. 5 SHAFTS AND GEARS

INDEX TO FIG. 5

<i>Illust. No.</i>	<i>Part No.</i>	<i>Page No.</i>	<i>Ref. No.</i>
1	T1403	18	1
2	T1405	18	2
3	T1410	18	5
4	T1406	18	3
5	T1391	18	4
6	T1411	18	6
7	T732	18	20
8	E2419	18	21
9	T1479	18	7
10	T1413	18	8
11	T1414	18	9
12	T1393	18	10
13	T1426	18	11
14	T1445	20	13
15	T1446	20	14
16	T1161	20	17
17	T1282	20	16
18	T1431	20	15

GROUP 3 — GEARBOX

REF. No.	PART No.	DESCRIPTION	QUANTITY
GEAR CHANGE MECHANISM			
1	T1480	Fork, mainshaft selector	1
2	T1481	Fork, layshaft selector	1
3	T1457	Spindle, selector forks	1
4	T1458	Camplate, gear selector	1
5	T1418	Spindle, camplate	1
6	—	Split pin, spindle $\frac{1}{8}$ " x 1"	1
7	T1416	Finger, gear indicator	1
8	H688	Screw, finger to spindle, $\frac{5}{16}$ " U.H.	1
INNER COVER AND KICKSTARTER			
9	T1448	Cover, gearbox inner	1
10	T1417	Plate, gear positions	1
11	D208-5	Screw, hammer drive	2
12	T1440	Dowel, hollow	2
13	T1445	SPINDLE, KICKSTARTER	1
14	T1446	Bush, layshaft to spindle	1
15	T1431	Pawl, kickstarter spindle	1
16	T1282	Plunger, kickstarter pawl	1
17	T1161	Spring, plunger	1
18	T1157	Plate, kickstarter stop	1
19	T1390	Screw, stop plate and spring anchor	1
20	T1464	Distance piece, spindle	1
21	T1441	Spring, kickstarter return	1
22	T1422	Plate, return spring	1
23	E3204	Screw, inner cover to casing, 1" U.H.	2
OUTER COVER AND CLUTCH LEVER			
24	T1450	COVER, GEARBOX OUTER	1
25	T1395	Bush, gear change spindle	1
26	T1388	Stud, spring housing, $1\frac{9}{16}$ " O.A.	2
27	E1987	Stud, spring housing, $1\frac{11}{16}$ " O.A.	1
28	T1483	QUADRANT, GEARCHANGE	1
29	T1474	Pin, spring anchoring	2
30	T1436	Spring, plunger	2
31	T1496	Plunger, gear selector	2
32	—	Split pin, $\frac{5}{16}$ " x $\frac{3}{4}$ "	2
33	T1484	LEVER AND WORM, CLUTCH OPERATING	1
34	S70-7	Ball, for clutch rod	1
35	T1462	Abutment, cable	1
36	E3302	Washer, cable abutment	1
37	—	Split pin, $\frac{1}{16}$ " x $\frac{3}{4}$ "	2

GEARBOX — GROUP 3

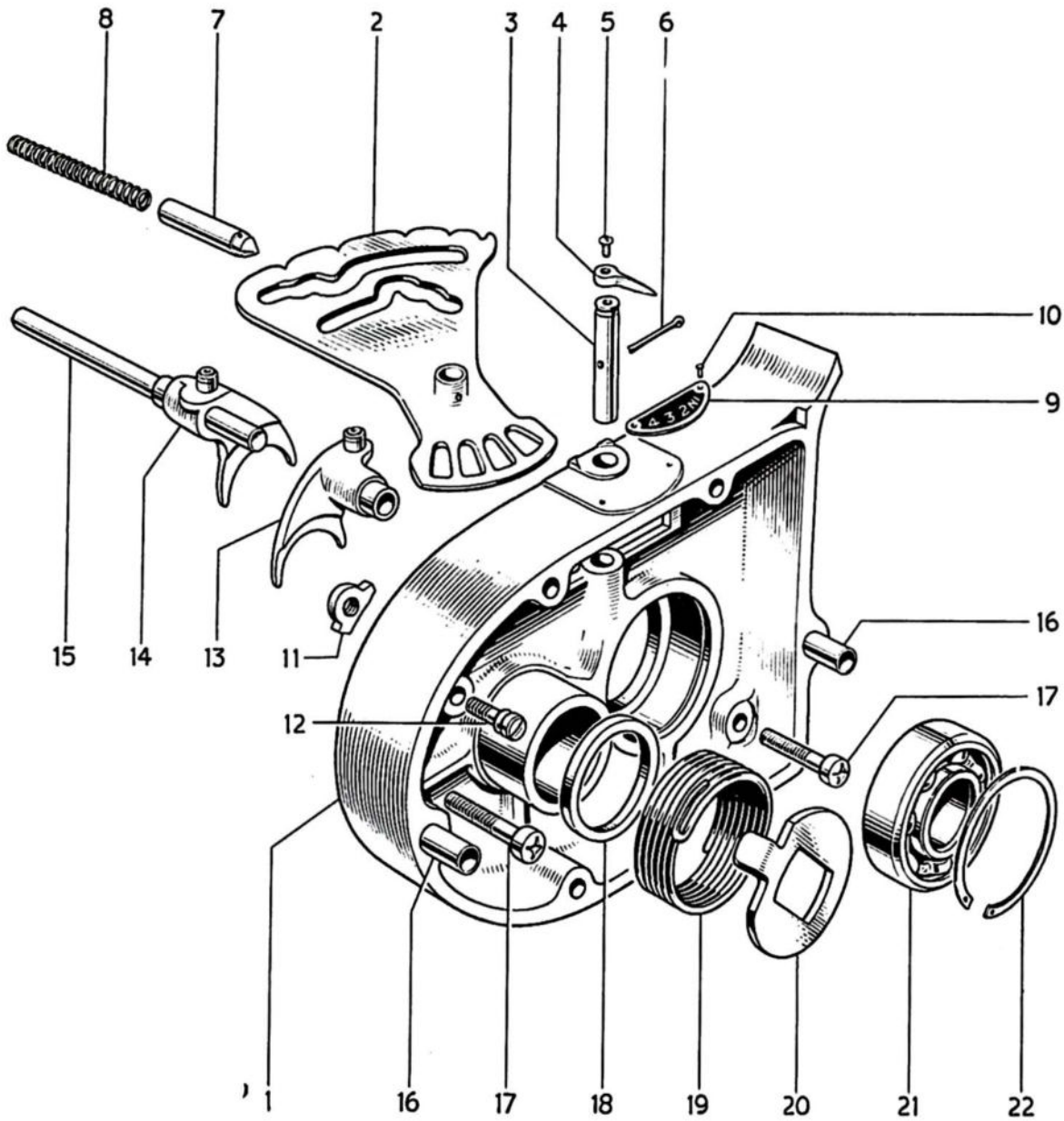

FIG. 6 GEARBOX INNER COVER

INDEX TO FIG. 6

Illust. No.	Part No.	Page No.	Ref. No.	Illust. No.	Part No.	Page No.	Ref. No.
1	T1448	20	9	12	T1390	20	19
2	T1458	20	4	13	T1481	20	2
3	T1457	20	3	14	T1480	20	1
4	T1416	20	7	15	T1457	20	3
5	H688	20	8	16	T1440	20	12
6	1/8" x 1" Split Pin	20	6	17	E3204	20	23
7	T1471	18	29	18	T1464	20	20
8	T373	18	30	19	T1441	20	21
9	T1417	20	10	20	T1422	20	22
10	D208-5	20	11	21	T1469	18	18
11	T1157	20	18	22	T280	18	19

GROUP 3 — GEARBOX

REF. No.	PART No.	DESCRIPTION	QUANTITY
1	T1385	Housing, quadrant return springs	1
2	T1432	Spring, quadrant return	2
3	T1433	Button, return spring	2
4	T1394	Cover, springs	1
5	S25-1	Washer, short stud	1
6	W103	Nut, housing to cover	3
7	T1465	Spring, clutch cable	1
8	E3475	Grommet, clutch cable	1
9	S1-51	Nut, cover to casing	2
10	S25-3	Washer	2
11	T1401	Screw, cover to casing, 2 $\frac{3}{8}$ " U.H.	2
12	T1402	Screw, cover to casing, 2 $\frac{5}{8}$ " U.H.	2

GEARCHANGE AND KICKSTARTER LEVERS

13	T1435	Lever, gearchange	1
14	T449	Rubber, gearchange lever	1
15	W932	Bolt, gearchange lever, 1" U.H.	1
16	T1485	LEVER, KICKSTARTER FOLDING	1
17	T1438	Crank, kickstarter	1
18	T1272	Pedal, kickstarter	1
19	S70-3	Ball, pedal index	1
20	T1167	Spring, pedal index	1
21	T1273	Bolt, pedal pivot	1
22	T1439	Bolt, lever clamp, 1 $\frac{3}{16}$ " U.H.	1
23	F1814	Rubber, kickstarter lever	1

GEARBOX SPROCKET AND COVER PLATE

24	T1476	Sprocket, gearbox (18 teeth)	1
25	T1434	Nut, gearbox sprocket	1
26	E3789	Plate, sprocket cover	1
27	E3832	Washer, cover plate joint	1
28	E3833	Seal, mainshaft oil	1
29	E3821	Screw, plate to crankcase, $\frac{5}{16}$ " U.H.	6

CLUTCH AND SHOCK ABSORBER

30	T1486	CLUTCH COMPLETE	1
31	T1386	Hub, clutch to shaft	1
32	T394	Roller, sprocket to hub	1
33	T1442	Sprocket and housing	1
34	T1041	Spider, shock absorber	1
35	T1039	Plate, shock absorber, inner	1
36	T1037	Centre housing, clutch	1

GEARBOX — GROUP 3

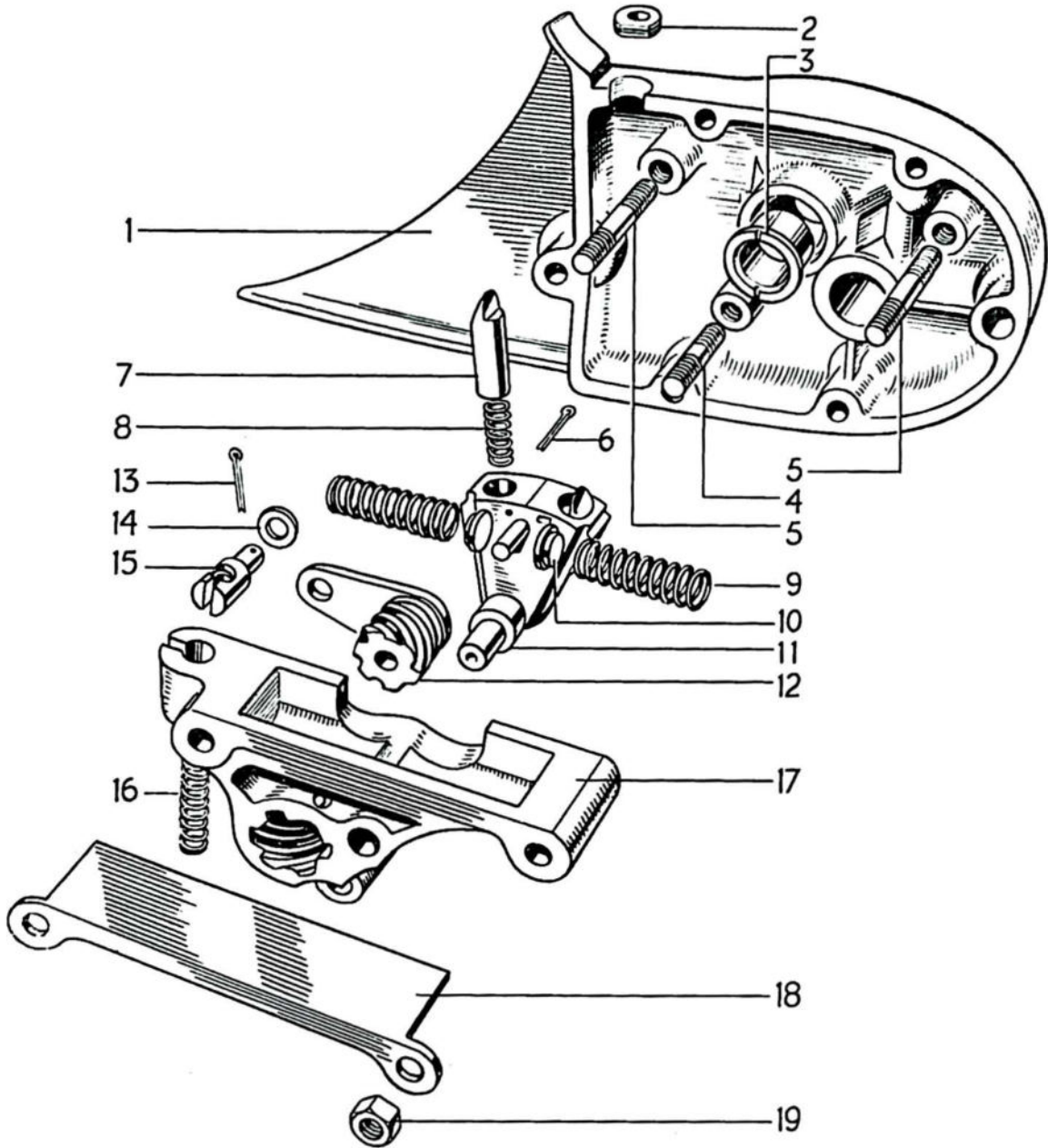

FIG. 7
GEARBOX OUTER COVER

INDEX TO FIG. 7

Illust. No.	Part No.	Page No.	Ref. No.	Illust. No.	Part No.	Page No.	Ref. No.
1	T1450	20	24	11	T1483	20	28
2	E3475	22	8	12	T1484	20	33
3	T1395	20	25	13	Split pin	20	37
4	E1987	20	27	14	E3302	20	36
5	T1388	20	26	15	T1462	20	35
6	Split pin	20	32	16	T1465	22	7
7	T1496	20	31	17	T1385	22	1
8	T1436	20	30	18	T1394	22	4
9	T1432	22	2	19	W103	22	6
10	T1433	22	3				

GROUP 3 — GEARBOX

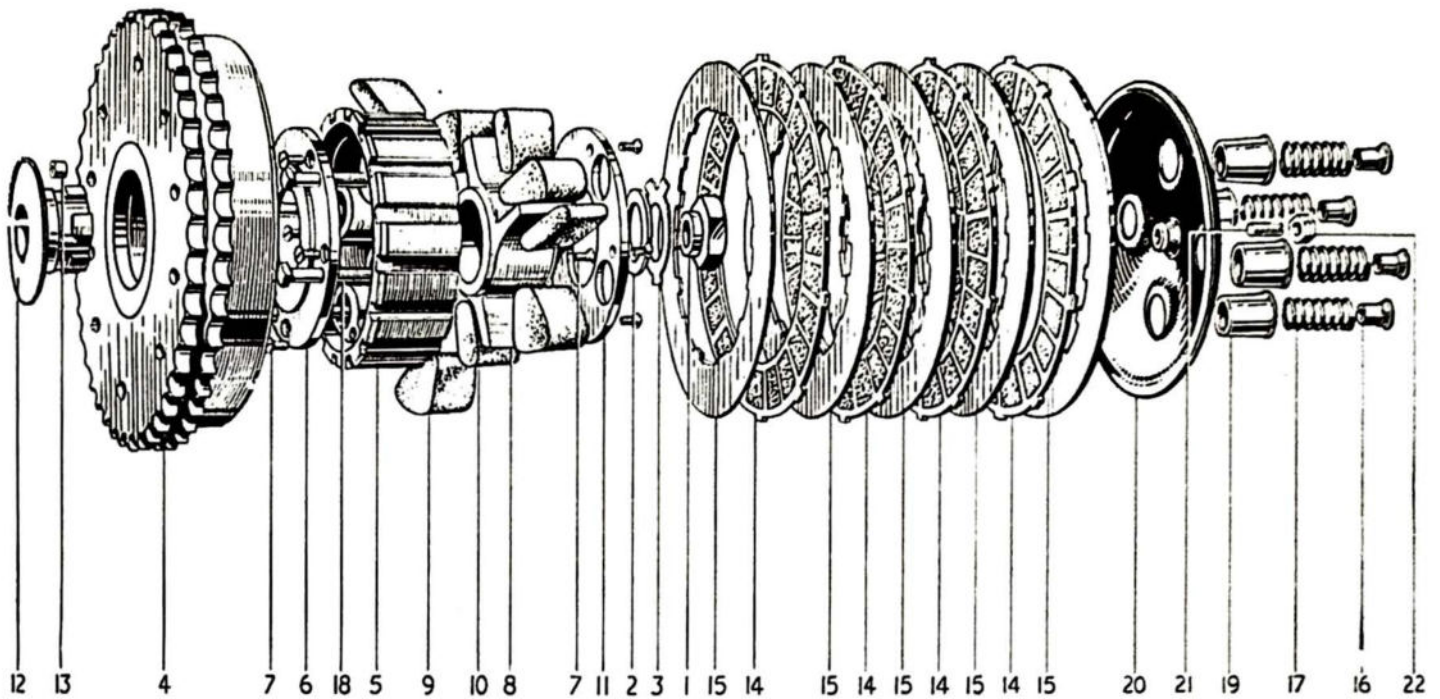

FIG. 8 CLUTCH AND SHOCK ABSORBER

INDEX TO FIG. 8

Illust. No.	Part No.	Page No.	Ref. No.	Illust. No.	Part No.	Page No.	Ref. No.
1	T1047	25	10	12	T1386	22	31
2	T1045	25	8	13	T394	22	32
3	T1046	25	9	14	T1362	24	6
4	T1442	22	33	15	T1363	24	7
5	T1037	22	36	16	T427	25	6
6	T1039	22	35	17	T429	25	5
7	T1040	24	4	18	T423	24	5
8	T1041	22	34	19	T425	25	4
9	T1472	24	1	20	T1466	25	1
10	T1473	24	2	21	T1256	25	2
11	T1044	24	3	22	GS662	25	3

REF. No.	PART No.	DESCRIPTION	QUANTITY
1	T1472	Rubber, driving (large)	4
2	T1473	Rubber, rebound (small)	4
3	T1044	Plate, shock absorber, outer	1
4	T1040	Screw, shock absorber plates, 0.417" U.H.	8
5	T423	Pin, pressure spring, 1 $\frac{1}{8}$ " U.H.	4
6	T1362	Plate, driving (with linings)	4
7	T1363	Plate, driven (plain)	5

GEARBOX — GROUP 3

EXHAUST SYSTEM — GROUP 4

REF. No.	PART No.	DESCRIPTION	QUANTITY
1	T1466	Plate, clutch pressure	1
2	T1256	Adjuster, pressure plate	1
3	GS662	Nut, adjuster lock	1
4	T425	Cup, pressure spring	4
5	T429	Spring, clutch pressure	4
6	T427	Nut, pressure spring	4
7	S66-1	Key, clutch to mainshaft	1
8	T1045	Washer, cupped	1
9	T1046	Washer, tab	1
10	T1047	Nut, clutch to mainshaft	1
11	T1456	Rod, clutch operating	1

CHAINCASE COVER

12	E3701	Cover, chaincase	1
13	E3850	Washer, cover joint	1
14	DS57	Plug, drain and level	2
15	WE170	Washer, drain and level plugs	2
16	E732	Plug, adjuster cover and filler	2
17	NE507	Washer, adjuster cover plug	2
18	E3802	Screw, chaincase cover, 2 $\frac{3}{4}$ " U.H.	3
19	E3668	Screw, chaincase cover, 1 $\frac{5}{16}$ " U.H.	7

For chain oiler jet see Page 13

EXHAUST SYSTEM—GROUP 4

20	E3864	Pipe, exhaust L.H.	1
21	E3865	Pipe, exhaust R.H.	1
22	E2269	Clip, pipe to head	2
23	E410A	Washer, clip bolt	2
24	E409	Bolt, clip, 1 $\frac{3}{16}$ " U.H.	2
25	F4283	Bracket, to bottom engine stud	2
26	DS57	Bolt, pipe to bracket, $\frac{7}{16}$ " U.H.	2
27	E1612	Washer, shakeproof	2
28	F879	Nut, bracket bolt	2
29	E3935	Silencer, L.H.	1
30	E3936	Silencer, R.H.	1
31	E2271	Clip, silencer to pipe	2
32	TE164E	Bolt, silencer clip, 1 $\frac{3}{16}$ " U.H.	2
33	TE164D	"D" Washer, clip bolt	2
34	TE164C	"D" nut, clip bolt	2

GROUP 5 — FRAME

REF. No.	PART No.	DESCRIPTION	QUANTITY
FRAME—GROUP 5			
1	F4157	Frame, front	1
2	KW194	Lubricator, fork pivot (grease nipple)	1
3	WE170	Washer, lubricator	1
4	F4158	Frame, rear	1
5	F2842	Stud, top rear frame, 3 $\frac{7}{8}$ " O.A.	1
6	S26-1	Washer, spring	2
7	SI-52	Nut, top stud	2
8	*F3780	Bolt, bottom rear frame, 1 $\frac{1}{16}$ " U.H.	2
9	PCW73A	Washer, spring	2

*Footrest bolts Page 27 also secure the lower frame joint

ENGINE PLATES AND STUDS

10	F4275	Plate, engine front L.H.	1
11	F4276	Plate, engine front R.H.	1
12	E3908	Stud, engine plates to crankcase, 3 $\frac{3}{16}$ " O.A.	3
13	S26-3	Washer, spring	6
14	H400	Nut, domed	6
15	F2825	Stud, engine plates to frame, 3 $\frac{1}{4}$ " O.A.	1
16	S26-1	Washer, spring	2
17	E1435	Nut, domed	2
18	E3812	Stud, engine bottom, 7 $\frac{13}{16}$ " O.A.	1
19	F4197	Distance piece, bottom stud	2
20	S26-1	Washer, spring	2
21	P0172A	Nut, bottom stud	2
22	F4229	Plate, engine rear L.H.	1
23	F4230	Plate, engine rear R.H.	1
24	F3665	Stud, engine plates to crankcase, 4 $\frac{1}{4}$ " O.A.	1
25	S26-1	Washer, spring	2
26	P0172A	Nut, engine plates stud	2
27	E3695	Stud, engine plates to frame, 4 $\frac{1}{8}$ " O.A.	2
28	S26-3	Washer, spring	4
29	SI-51	Nut, engine plates stud	4

ENGINE TORQUE STAYS

30	E3860	Stay, engine torque L.H.	1
31	E3861	Stay, engine torque R.H.	1
32	S26-1	Washer, spring	2
33	SI-52	Nut, cylinder head bolts	2
34	E3862	Clip, stays to frame	1
35	DS58	Bolt, clip, $\frac{3}{8}$ " U.H.	1
36	S26-3	Washer, spring	1
37	SI-51	Nut, clip bolt	1

FRAME — GROUP 5

REF. No.	PART No.	DESCRIPTION	QUANTITY
SWINGING FORK			
1	F4190	FORK, SWINGING C/W BUSHES	1
2	F4076	Bush, fork pivot	2
3	F4195	Spindle, swinging fork	1
4	F4078	Washer, spacing R.H.	1
5	F4385	Shim, .003" thick	as necessary
6	F4386	Shim, .005" thick	as necessary
7	F3797	Rod, spindle caps	1
8	F4196	Cap, spindle retaining	2
9	F3799	Nut, retaining rod	1
CENTRE STAND			
10	F4402	Stand, centre	1
11	T449	Rubber, extension arm	1
12	F3617	Spring, stand return	1
13	F3619	Bolt, pivot	2
14	F2725	Nut, pivot bolt	2
PROP STAND			
15	F4388	Stand, prop	1
16	F3097	Pin, stand swivel	1
17	F3096	Washer, tab	1
18	F2610	Spring, stand return	1
FOOTRESTS			
19	F4214	Footrest, L.H.	1
20	F4215	Footrest, R.H.	1
21	NF704	Rubber, footrest	2
22	F4369	Bolt, footrests to frame, 2 $\frac{11}{16}$ " U.H.	2
23	F4370	Washer, footrest nut	2
24	DS47	Nut, footrest bolt	2
PILLION FOOTRESTS			
25	F4407	Support, pillion footrest L.H.	1
26	F4410	Support, pillion footrest R.H.	1
27	E1396	Stud, support to frame, $\frac{11}{16}$ " O.A.	4
28	S1-51	Nut, support stud	4
29	S26-3	Washer, spring	4
30	F4327	FOOTREST, PILLION COMPLETE	2
31	F1694	Pedal, pillion footrest	2
32	F2268	Hanger, pillion footrest	2
33	F4309	Stud, hanger, 1 $\frac{3}{8}$ " O.A.	2
34	F2271	Bolt, pivot	2
35	F2277	Washer, Thackeray	2
36	S1-51	Nut, pivot bolt	2
37	P0172A	Nut, hanger stud	2
38	S26-1	Washer, spring	2
39	F1695	Rubber, pillion footrest	2

GROUP 5 — FRAME

REF. No.	PART No.	DESCRIPTION	QUANTITY
BRAKE PEDAL			
1	F4284	Spindle, brake pedal	1
2	DS48	Nut, spindle to frame	1
3	SCZ45	Washer, spring	1
4	F4314	Pedal, brake	1
5	F1149	Adjuster, pedal position, $\frac{15}{16}$ " U.H.	1
6	F879	Nut, adjuster lock	1
7	S26-16	Washer, spring outer	1
8	S25-2	Washer, plain outer	1
9	S1-52	Nut, outer	1
10	F3597	Rod, brake operating	1
11	S25-13	Washer, split pin	1
12	—	Split pin, rod to pedal, $\frac{1}{16}$ " x $\frac{1}{2}$ "	1
13	F3667	Nut, thumb adjuster brake rod	1

INDEX TO FIG. 9

Illust. No.	Part No.	Page No.	Ref. No.	Illust. No.	Part No.	Page No.	Ref. No.
1	F4157	26	1	26	E3695	26	27
2	F2842	26	5	27	F4283	25	25
3	S1-52	26	7	28	H1130	33	1
4	F4276	26	11	29	F1695	27	39
5	F2825	26	15	30	F4402	27	10
6	E1435	26	17	31	F3619	27	13
7	F4275	26	10	32	F2725	27	14
8	F4230	26	23	33	F4314	28	4
9	F4229	26	22	34	F4284	28	1
10	F3665	26	24	35	S1-52	28	9
11	F4158	26	4	36	S25-2	28	8
12	F3780	26	8	37	S26-16	28	7
13	E1396	27	27	38	F3597	28	10
14	F4407	27	25	39	Split pin	28	12
	F4410	27	26	40	S25-13	28	11
15	F4327	27	30	41	F3667	28	13
16	F4190	27	1	42	F4214	27	19
17	F4076	27	2	43	NF704	27	21
18	F4078	27	4	44	F4369	27	22
19	F4195	27	3	45	DS47	27	24
20	F3797	27	7	42	F4214	27	19
21	F4196	27	8		F4215	27	20
22	F3799	27	9	43	NF704	27	21
23	E3812	26	18	44	F4369	27	22
24	PO172A	26	21	45	DS47	27	24
25	F4197	26	19				

FRAME — GROUP 5

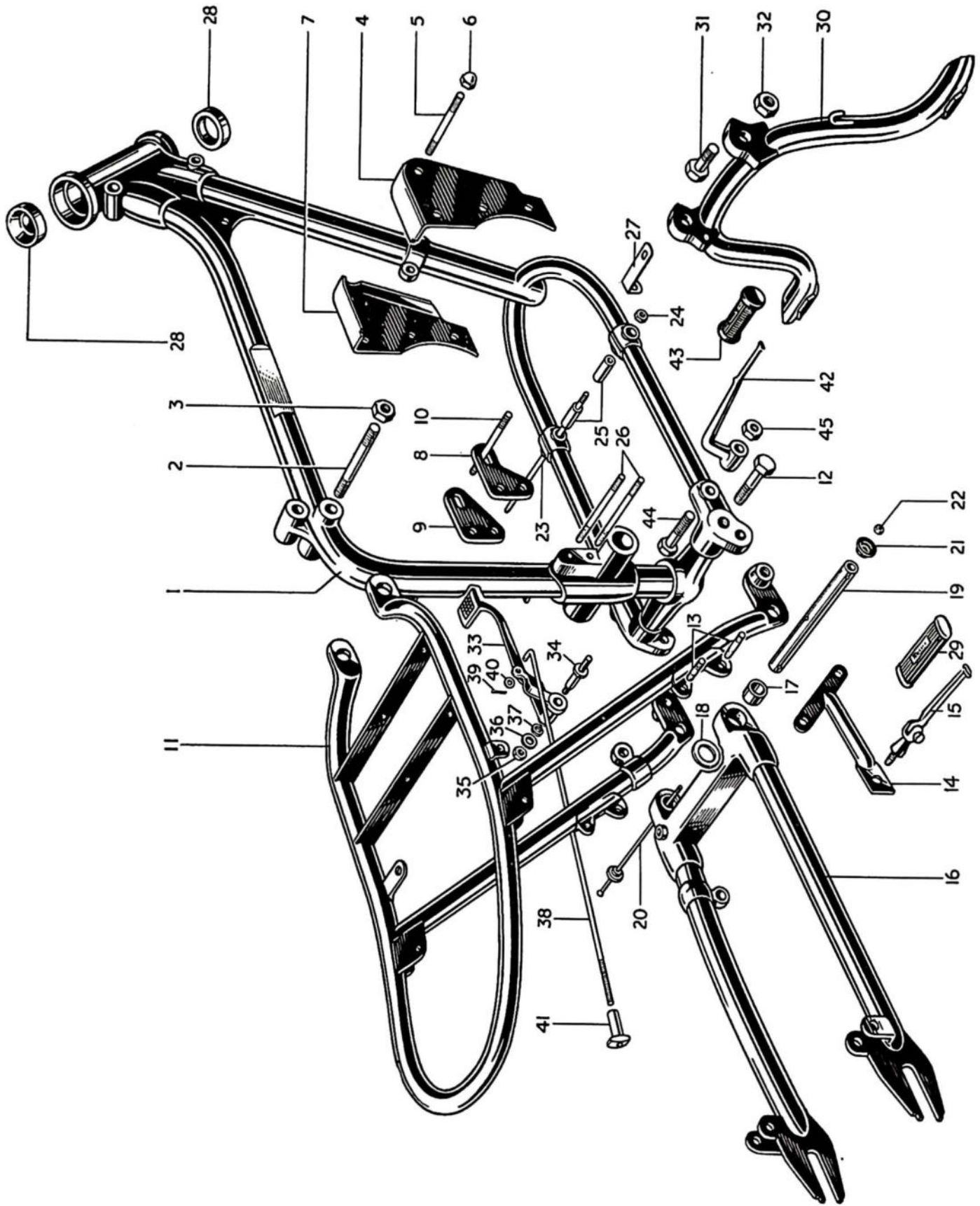

FIG. 9 FRAME AND FITTINGS

GROUP 6 — FRONT FORK

REF. No.	PART No.	DESCRIPTION	QUANTITY
TELESCOPIC FRONT FORK—GROUP 6			
1	H1174	FORK ASSEMBLY	1
2	H1112	Lug, middle and stem	1
3	H941	Bolt, middle lug pinch, 2 $\frac{1}{4}$ " U.H.	2
4	S25-2	Washer, pinch bolt	2
5	E2412	Nut, pinch bolt	2
6	H1108	Lug, fork top	1
7	F1760	Bolt, top lug pinch, 1 $\frac{11}{16}$ " U.H.	1
8	H379	Nut, pinch bolt	1
9	H660	"U" bolt, handlebar clamp	2
10	S25-3	Washer, plain	4
11	E1310	Nut, "U" bolt	4
12	H1141	Nut, fork stem sleeve	1
13	H1123	STANCHION C/W BEARING	2
14	H443	Bearing, stanchion lower	2
15	H1058	Nut, bearing to stanchion	2
16	H519A	Plug, stanchion oil filler, $\frac{3}{16}$ " U.H.	2
17	H430	Washer, fibre	2

INDEX TO FIG. 10

Illust. No.	Part No.	Page No.	Ref. No.	Illust. No.	Part No.	Page No.	Ref. No.
1	H1108	30	6	27	H1123	30	13
2	F1760	30	7	28	H519A	30	16
3	H379	30	8	29	H430	30	17
4	H660	30	9	30	H1065	32	26
5	E1310	30	11	31	H443	30	14
6	H1112	30	2	32	H1058	30	15
7	H1141	30	12	33	H1127	32	22
8	H941	30	3	34	H1062	32	12
9	E2412	30	5	35	H1063	32	11
10	H1145	32	27	36	H565	32	31
11	H1146	32	28	37	H1110	33	3
12	H1144	33	5	38	H408	32	32
13	H877	33	12	39	H409	32	33
14	H878	33	13	40	H1142	32	30
15	H1196	32	17	41	H1111	32	35
16	H1117	32	1	42	F3468	32	37
17	H1118	32	5	43	S1-51	32	39
18	H1071	32	9	44	H435	32	34
19	H430	32	10	45	H95	32	36
20	H1053	32	2	46	F3098	32	38
21	H1070	32	4	47	H1066	32	25
22	H1195	32	15	48	H1051	32	24
23	H1168	32	16	49	H1125	32	21
24	H441	32	14	50	H1061	32	19
25	H1126	32	13	51	H1060	32	20
26	H420	32	29	52	H1140	33	2

FRONT FORK — GROUP 6

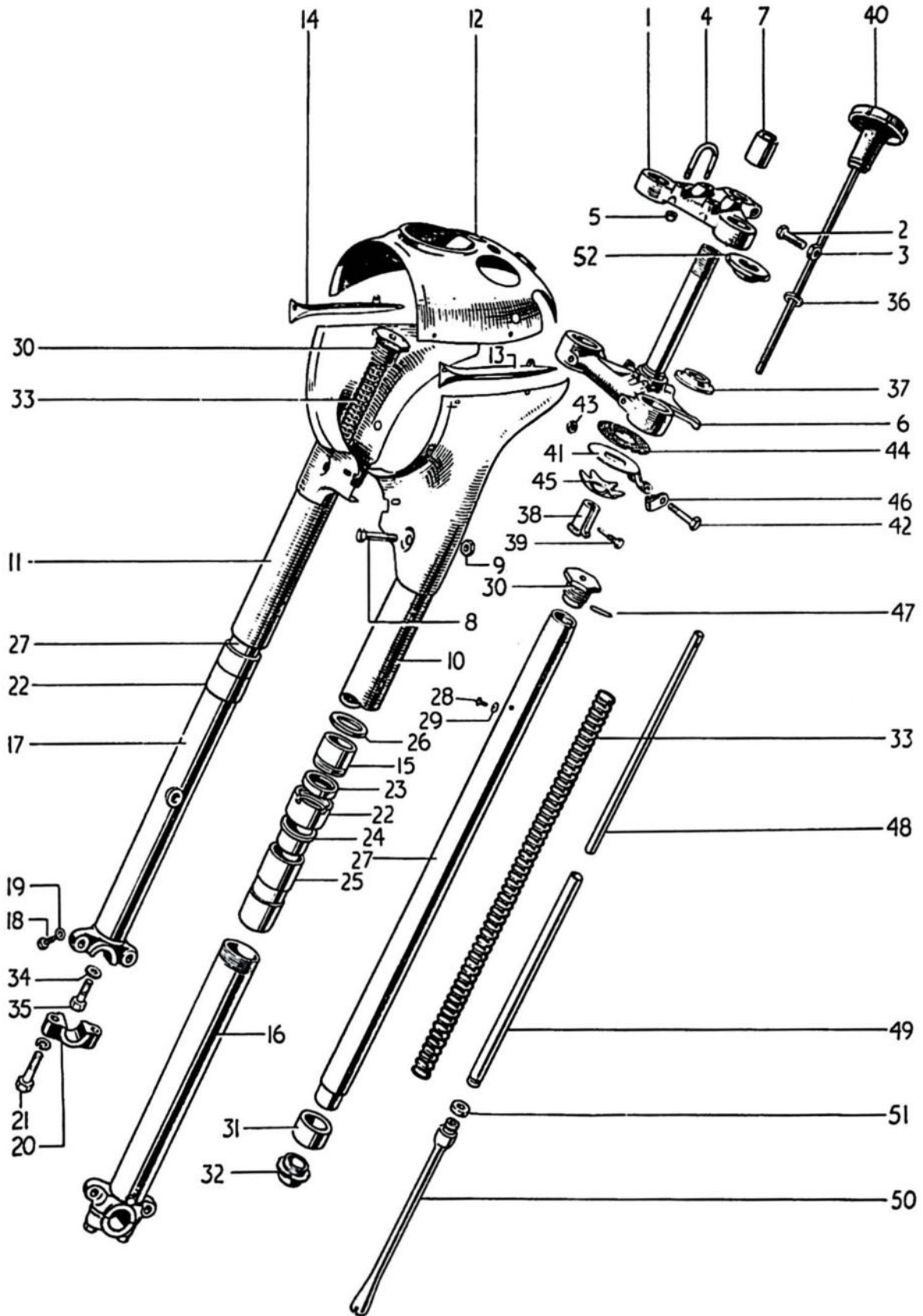

FIG. 10 TELESCOPIC FRONT FORK

FRONT FORK — GROUP 6

REF. No.	PART No.	DESCRIPTION	QUANTITY
1	H1117	BOTTOM MEMBER, L.H. COMPLETE	1
2	H1053	Cap, wheel spindle	1
3	S26-3	Washer, spring	2
4	H1070	Bolt, spindle cap, $1\frac{7}{16}$ " U.H.	2
5	H1118	BOTTOM MEMBER, R.H. COMPLETE	1
6	H1053	Cap, wheel spindle	1
7	S26-3	Washer, spring	2
8	H1070	Bolt, spindle cap, $1\frac{7}{16}$ " U.H.	2
9	H1071	Plug, drain	2
10	H430	Washer, fibre	2
11	H1063	Bolt, restrictor to bottom lug, $\frac{7}{8}$ " U.H.	2
12	H1062	Washer, aluminium	2
13	H1126	Sleeve, bottom member	2
14	H441	Bearing, bottom member	2
15	H1195	Nut, dust excluder sleeve	2
16	H1168	Seal, oil	2
17	H1196	Shroud, dust excluder	2
18	H1124	RESTRICTOR ROD ASSEMBLY	2
19	H1061	Rod, restrictor	2
20	H1060	Washer, spring support	2
21	H1125	Tube, lower guide	2
22	H1127	Spring, main (identification YELLOW)	2
23	H1064	CAP NUT ASSEMBLY	2
24	H1051	Tube, upper guide	2
25	H1066	Pin, tube to nut	2
26	H1065	Nut, stanchion cap	2
27	H1145	Cover, nacelle L.H.	1
28	H1146	Cover, nacelle R.H.	1
29	H420	Washer, felt nacelle cover	2
30	H1142	Rod and knob, steering damper	1
31	H565	Washer, abutment	1
32	H408	Sleeve, damper adjusting	1
33	H409	Pin, sleeve to middle lug	1
34	H435	Disc, friction	1
35	H1111	Plate, damper anchor	1
36	H95	Spring, anchor plate	1
37	F3468	Bolt, damper anchor, $2\frac{1}{16}$ " U.H.	1
38	F3098	Clip, speedometer cable	1
39	SI-51	Nut, anchor bolt	1

FRONT FORK — GROUP 6

REF. No.	PART No.	DESCRIPTION	QUANTITY
STEERING RACES			
1	H1130	Cup, frame lug, top and bottom	2
2	H1140	Cone and dust cover, top lug	1
3	H1110	Cone, middle lug	1
4	S70-4	Ball, top and bottom races, $\frac{3}{16}$ " dia.	48
NACELLE TOP AND MOTIFS			
5	H1144	Top unit, nacelle	1
6	H961	Grommet, control cables	3
7	H669	Grommet, handlebar	2
8	H992	Grille, horn	1
9	H993	Screw, grille fixing, 0.540" U.H.	2
10	GS299	Washer, shakeproof	2
11	F3799	Nut, grille screw	2
12	H877	Motif (flash), L.H.	1
13	H878	Motif (flash), R.H.	1
14	H688	Screw, motif front, $\frac{5}{16}$ " U.H.	2
15	H689	Screw, top and bottom units, $\frac{1}{4}$ " U.H.	2
16	E2880	Washer, shakeproof	4
17	H691	Nut, front and rear screws	4
18	H687	Screw, motif to top lug, $\frac{3}{8}$ " U.H.	2

SPECIAL WORKSHOP TOOLS

A COMPLETE LIST OF WORKSHOP TOOLS CAN BE MADE AVAILABLE BY EITHER CONTACTING YOUR DEALER OR APPLYING DIRECT TO THE TRIUMPH SERVICE DEPARTMENT. IN MOST CASES THESE TOOLS ARE VERY COSTLY AS THEY ARE MADE ENTIRELY FOR WORKSHOP USE, AND THEREFORE, IT IS NOT RECOMMENDED THAT THE PRIVATE OWNER PURCHASES THE TOOLS IN ORDER TO AID SERVICING THE MACHINE ONCE OR TWICE ONLY. IN THESE CIRCUMSTANCES IT IS FAR MORE ECONOMICAL TO GET IN TOUCH WITH A RECOGNISED DEALER.

GROUP 7 — FRONT WHEEL

REF. No.	PART No.	DESCRIPTION	QUANTITY
FRONT WHEEL—GROUP 7			
1	WI311	WHEEL, FRONT COMPLETE	1
2	WI273	RIM, SPOKES AND HUB ASSEMBLY	1
3	WI274	Rim, WM2-17	1
4	WI275	Spoke, straight, 5 $\frac{1}{16}$ " c/w nipple	40
5	S79-2	Nipple	40
6	WI231	Brake drum and hub	1
7	WI334	Plate, hub cover L.H.	1
8	W653	Bearing, L.H. and R.H.	2
9	WI237	Cover, L.H. bearing	1
10	T280	Circlip, L.H. bearing cover	1
11	WI238	Ring, R.H., bearing backing	1
12	W582	Ring, nut, R.H., bearing retaining	1
13	WI239	Spindle, front wheel	1

INDEX TO FIG. II

Illust. No.	Part No.	Page No.	Ref. No.	Illust. No.	Part No.	Page No.	Ref. No.
1	WI334	34	7	13	WI301	36	1
2	T280	34	10	14	W592	36	12
3	WI237	34	9	15	WI298	36	11
4	W653	34	8	16	S25-6	36	14
5	WI239	34	13	17	SI-52	36	13
6	S79-2	34	5	18	WI35	36	9
7	WI275	34	4	19	WI302	36	2
8	WI231	34	6	20	NW243	36	7
9	WI238	34	11	21	WI29	36	8
10	W582	34	12	22	WI246	36	10
11	W93	36	6	23	S25-2	36	3
12	WI243	36	5	24	EI435	36	4

FRONT WHEEL — GROUP 7

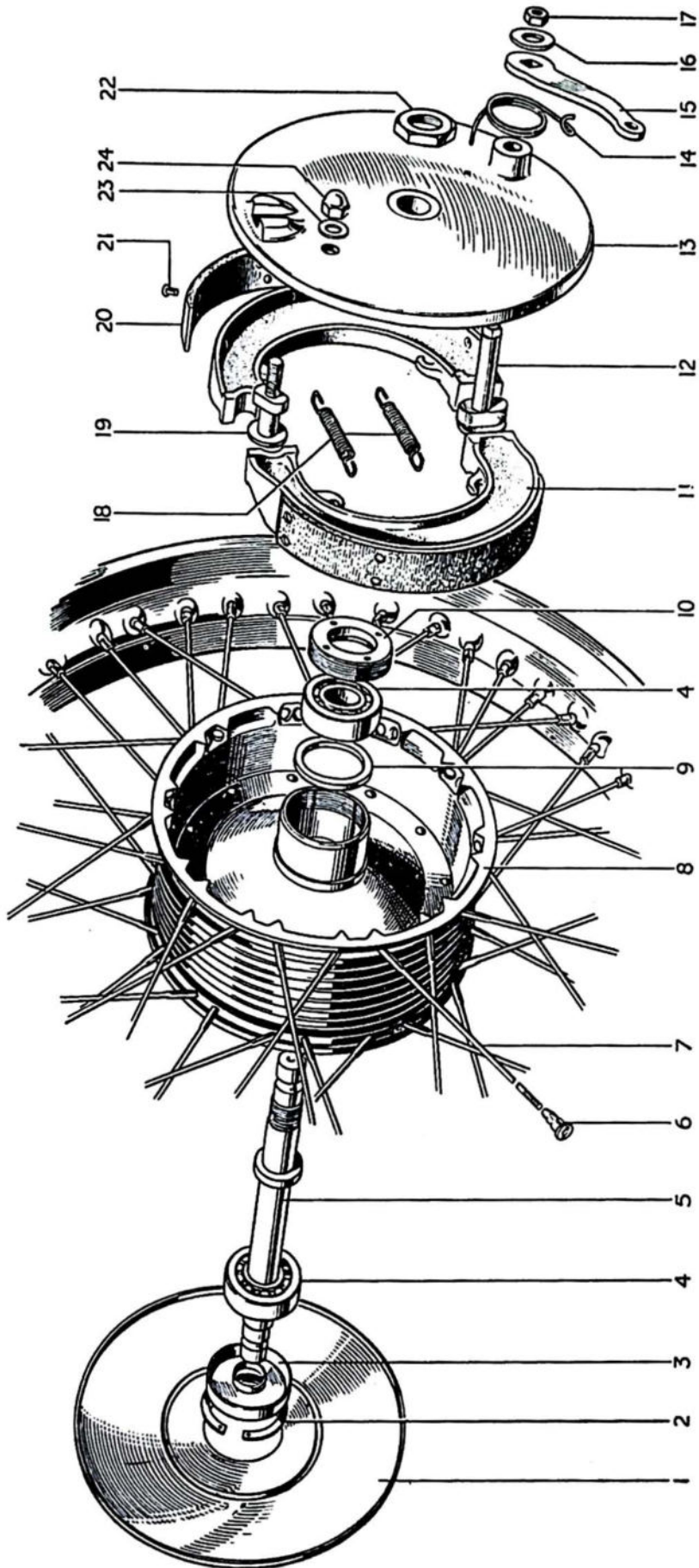

FIG. 11 FRONT WHEEL

GROUP 7 — FRONT WHEEL

REF. No.	PART No.	DESCRIPTION	QUANTITY
FRONT BRAKE			
1	WI301	Plate, front brake anchor	1
2	WI302	Pin, shoe fulcrum	1
3	S25-2	Washer, nut	1
4	E1435	Nut, fulcrum pin domed	1
5	WI243	Cam, brake operating	1
6	W93	SHOE, BRAKE C/W LINING	2
7	NW243	Lining, brake shoe	2
8	WI29	Rivet, brake lining	16
9	WI35	Spring, shoe return	2
10	WI246	Nut, anchor plate to spindle	1
11	WI298	Lever, brake cam	1
12	W592	Spring, lever return	1
13	S1-52	Nut, lever to cam	1
14	S25-6	Washer, lever nut	1
15	WF32	Pin, cable to lever	1
16	—	Split pin, $\frac{1}{16}$ " \times $\frac{1}{2}$ "	1

INDEX TO FIG. 12

Illust. No.	Part No.	Page No.	Ref. No.	Illust. No.	Part No.	Page No.	Ref. No.
1	F1747	38	39	20	S1-52	38	26
2	WI282	38	28	21	WI090	38	25
3	WI316	38	24	22	WI35	38	23
4	WI112	38	18	23	WI083	38	19
5	W93	38	20	24	WI079	38	16
6	NW243	38	21	25	WI021	38	15
7	WI29	38	22	26	WI022	38	14
8	WI024	38	27	27	WI266	38	7
9	WI276	38	8	28	WI271	38	5
10	W63	38	10	29	S79-2	38	6
11	W62	38	9	30	WI270	38	4
12	WI278	38	17	31	WI281	38	12
13	WI271	38	5	32	WI277	38	29
14	WI270	38	4	33	S1-51	38	11
15	W653	38	13	34	WI272	38	3
16	DS57	38	30	35	D373	38	33
17	WI134	38	36	36	WI279	38	32
18	WI015	38	37	37	WI280	38	34
19	WI058	38	38				

REAR WHEEL — GROUP 8

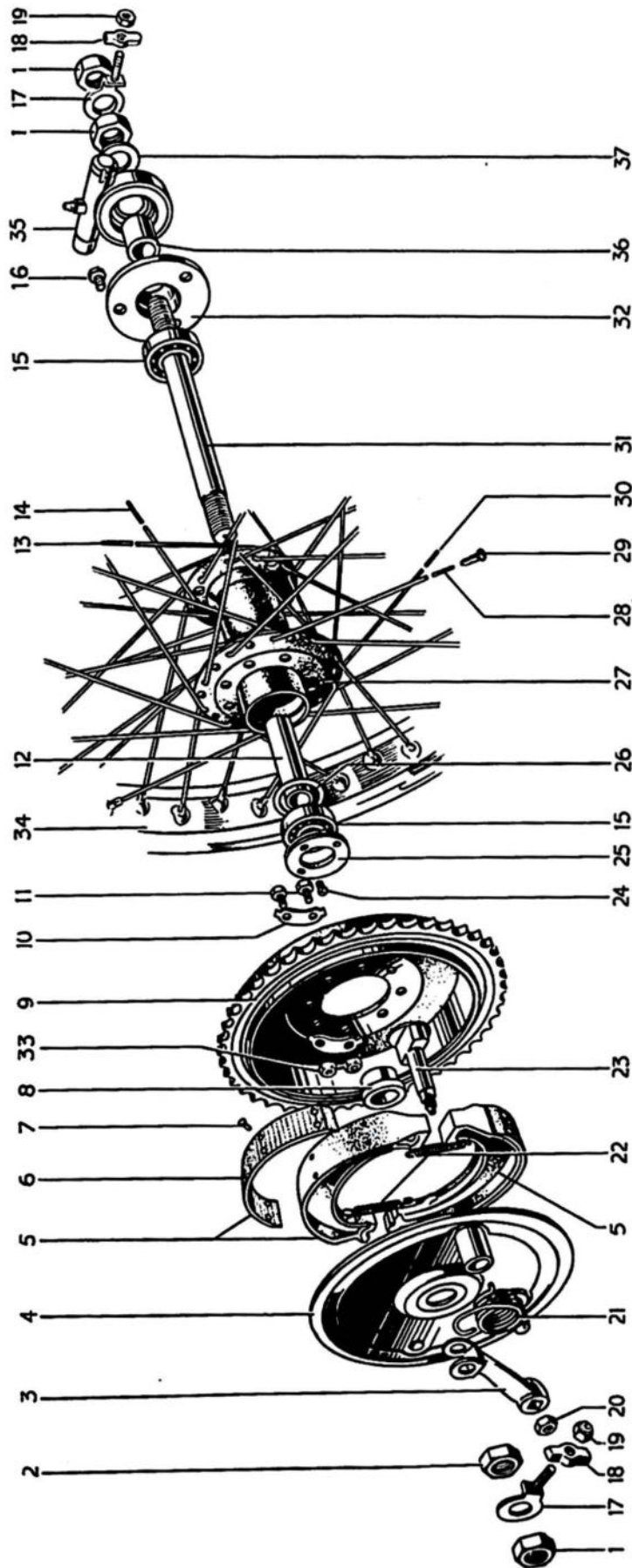

FIG. 12 REAR WHEEL

GROUP 8 — REAR WHEEL

REF. No.	PART No.	DESCRIPTION	QUANTITY
REAR WHEEL—GROUP 8			
1	WI313	WHEEL, REAR COMPLETE	1
2	WI265	RIM, SPOKES AND HUB ASSEMBLY	1
3	WI272	Rim, WM2-17	1
4	WI270	Spoke, inner, 110° x 7 $\frac{1}{8}$ " c/w nipple	20
5	WI271	Spoke, outer, 90° x 7 $\frac{1}{8}$ " c/w nipple	20
6	S79-2	Nipple	40
7	WI266	Hub	1
8	WI276	Brake drum and sprocket, 43T	1
9	W62	Bolt, drum to hub, $\frac{11}{16}$ " U.H.	8
10	W63	Lockplate, bolt and nut	8
11	SI-51	Nut, drum bolt	8
12	WI281	Spindle, wheel	1
13	W653	Bearing, L.H. and R.H.	2
14	WI022	Ring, L.H., bearing backing	1
15	WI021	RING, L.H., BEARING RETAINING	1
16	WI079	Screw, retainer locking	1
17	WI278	Tube, bearing distance	1
REAR BRAKE			
18	WI112	Plate, rear brake anchor	1
19	WI083	Cam, brake operating	1
20	W93	SHOE, BRAKE C/W LINING	2
21	NW243	Lining, brake shoe	2
22	WI29	Rivet, brake lining	2
23	WI35	Spring, shoe return	2
24	WI316	Lever, brake operating	1
25	WI090	Spring, lever return	1
26	SI-52	Nut, lever to cam	1
27	WI024	Distance, piece, anchor plate	1
28	WI282	Nut, anchor plate to spindle	1
SPEEDOMETER DRIVE			
29	WI277	Adaptor, speedometer drive	1
30	DS57	Bolt, adaptor to hub, $\frac{7}{16}$ " U.H.	3
31	E1612	Washer, shakeproof	3
32	WI279	Distance piece, gearbox	1
33	D373	Gearbox, speedometer drive	1
34	WI280	Washer, plain	1
35	FI747	Nut, gearbox to spindle	1
CHAIN ADJUSTERS			
36	WI134	Adjuster, rear chain	2
37	WI015	Plate, adjuster end	2
38	WI058	Nut, adjuster end plate	2
39	FI747	Nut, spindle outer	2

FRONT MUDGUARD — GROUP 9 REAR MUDGUARD — GROUP 10

REF. No.	PART No.	DESCRIPTION	QUANTITY
FRONT MUDGUARD—GROUP 9			
1	H1097	Mudguard, front	1
2	F4299	Washer, mudguard bolt	2
3	F929	Bolt, mudguard to fork leg, $\frac{1}{2}$ " U.H.	2
4	H1171	Clip, front brake cable	1
5	H916	Screw, clip, $\frac{9}{32}$ " U.H.	1
6	GS299	Washer, clip	1
7	H745	Nut, clip	1
FRONT STAND			
8	H1100	Stand, front	1
9	W62	Bolt, stand pivot, $\frac{11}{16}$ " U.H.	2
10	S25-2	Washer, pivot bolt	2
11	NS362	Nut, mudguard to stand	1
FRONT NUMBER PLATE			
12	F2698	Plate, front number	1
13	H251	Beading, rubber	1
14	F4332	Packing piece, front	1
15	F879	Nut, plate to mudguard	2
16	S26-2	Washer, spring	2
LICENCE HOLDER			
17	D261	Licence holder	1
18	DS57	Bolt, to mudguard, $\frac{7}{16}$ " U.H.	1
19	E1612	Washer, shakeproof	1
20	F879	Nut	1
REAR MUDGUARD AND PANELS—GROUP 10			
REAR MUDGUARD			
21	F4297	Mudguard, rear	1
22	DS57	Bolt, to bottom frame lug, $\frac{7}{16}$ " U.H.	1
23	S26-2	Washer, spring	1
24	GS218	Bolt, to top rail bracket, $\frac{9}{16}$ " U.H.	1
25	S25-13	Washer, top bolt	1
26	F879	Nut, top bolt	1
REAR PANELS			
27	F4144	Panel, L.H., rear	1
28	F4145	Panel, R.H., rear	1
29	F4312	Motif, "Twenty-one"	2
30	F4317	Spire nut, motif	6
31	F4325	Screw, self-tapping (4 top, 2 front)	6
32	F4326	Spire nut, front screws	2
33	F4249	Beading, rubber rear	1
34	F1369	Bolt, rear joint and number plate top, $\frac{5}{8}$ " U.H.	3
35	S25-13	Washer, plain	3
36	F879	Nut	3

GROUP 10 — REAR MUDGUARD
GROUP 11 — REAR CHAINGUARD

REF. No. PART No. DESCRIPTION QUANTITY

REAR NUMBER PLATE

1	F4245	Plate, rear number	1
2	F1369	Bolt, bottom, $\frac{5}{8}$ " U.H.	2
3	S26-2	Washer, spring	2
4	F879	Nut	2

Top bolt also secures panel joint

5
6
7

REAR CHAINGUARDS—GROUP 11

UPPER REAR CHAINGUARD

5	F4198	Chainguard, upper	1
6	F4134	Bracket, front pivot	1
7	DS57	Bolt, bracket to fork, $\frac{7}{16}$ " U.H.	1
8	S26-2	Washer, spring	1
9	F4135	Bolt, pivot	1
10	F2277	Washer, Thackeray (spring)	1
11	S25-13	Washer, plain	1
12	F879	Nut, pivot bolt	1
13	F4136	Bolt, rear	1
14	S25-3	Washer, plain	1
15	SI-51	Nut, rear bolt	1

LOWER REAR CHAINGUARD

16	F4199	Chainguard, lower	1
17	W840	Bolt, chainguard to fork, $\frac{13}{16}$ " U.H.	1
18	E2288	Washer, shakeproof	1
19	DS47	Nut, chainguard to brake plate	1
20	PCW73A	Washer, spring	1

INDEX TO FIG. 13

Illust. No.	Part No.	Page No.	Ref. No.	Illust. No.	Part No.	Page No.	Ref. No.
1	F4145	39	28	12	DS57	39	22
2	F4144	39	29	13	F4198	40	5
3	F4325	39	31	14	F4136	40	13
4	F4249	39	33	15	SI-51	40	15
5	F4245	40	1	16	F4134	40	6
6	F1369	40	2	17	F2277	40	10
7	F1369	39	34	18	F4135	40	9
8	F879	39	36	19	F879	40	12
9	F4312	39	29	20	DS57	40	7
10	F4317	39	30	21	F4199	40	16
11	F4297	39	21	22	W840	40	17

REAR CHAINGUARD — GROUP II

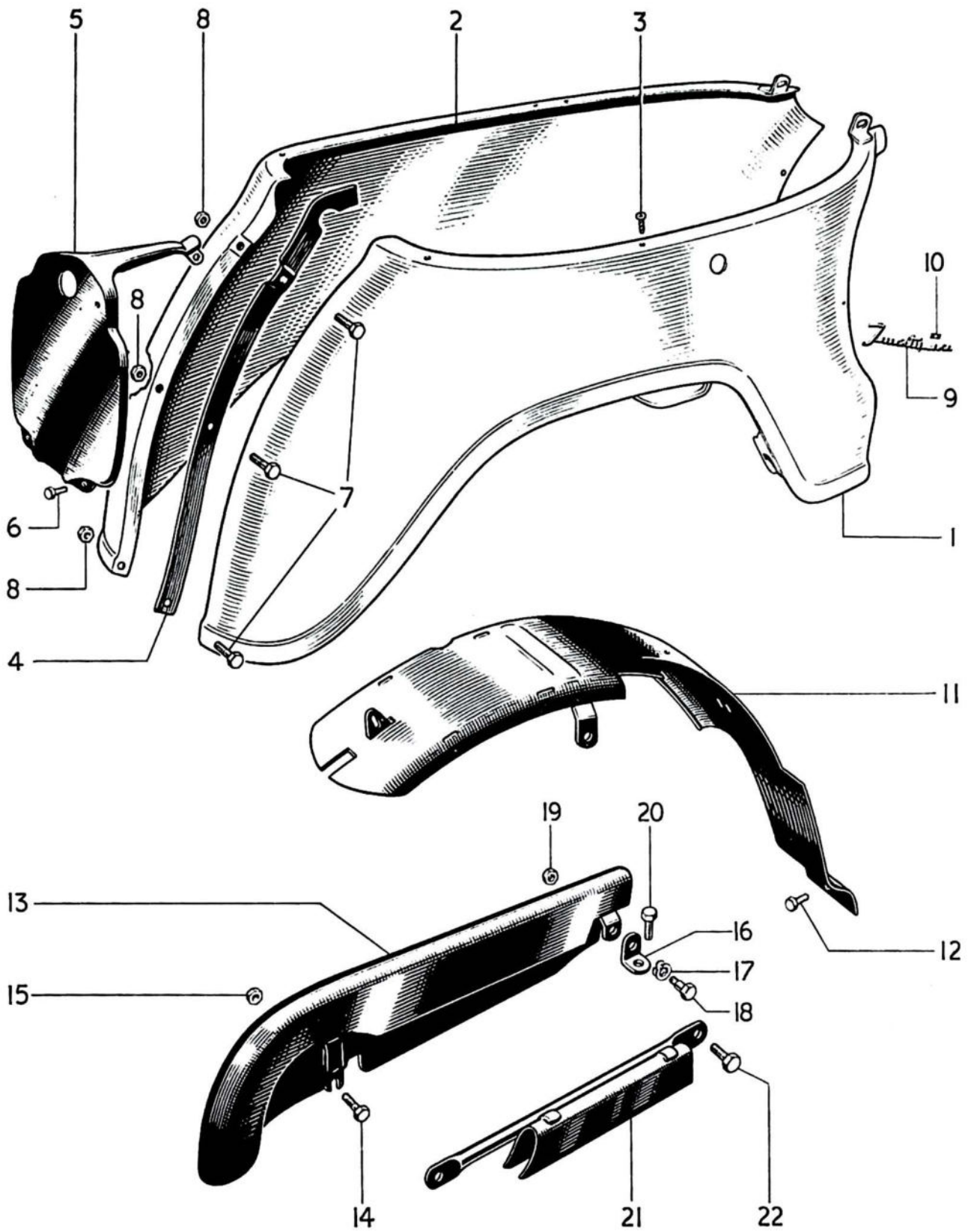

FIG. 13 REAR MUDGUARD, CHAINGUARD AND PANELS

GROUP 12 — PETROL TANK

REF. No.	PART No.	DESCRIPTION	QUANTITY
PETROL TANK—GROUP 12			
1	F4232	Tank, petrol	1
2	F3220	CAP, PETROL FILLER	1
3	F4048	Washer, cap joint	1
4	F4235	Styling strip, L.H., front	1
5	F4323	Styling strip, L.H., rear	1
6	F4237	Styling strip, R.H., front	1
7	F4324	Styling strip, R.H., rear	1
8	F4127	Styling unit, L.H.	1
9	F4128	Styling unit, R.H.	1
10	F4129	Screw, unit securing, .435" U.H.	4
11	F4398	Styling strip, centre	1
12	F4019	Washer, shakeproof	1
13	H919	Nut, centre strip	1
14	F2551	Knee grip, L.H.	1
15	F2552	Knee grip, R.H.	1
16	F1953	Screw, knee grip securing, $\frac{5}{8}$ " U.H.	4
17	F4384	Plug, parcel grid screw holes	4
18	F4382	Bolt, tank to frame front, $3\frac{1}{2}$ " U.H.	1
19	E1435	Nut, front bolt domed	1
20	E327	Bolt, tank to frame rear, $3\frac{3}{8}$ " U.H.	1
21	W76	Nut, rear bolt	1
22	E2288	Washer, shakeproof front and rear	2

PETROL TAP AND PIPE

23	F1717	Tap, petrol feed	1
24	F1511	Washer, tap to tank	1
25	F4308	Pipe, petrol feed (complete)	1

INDEX TO FIG. 14

Illust. No.	Part No.	Page No.	Ref. No.	Illust. No.	Part No.	Page No.	Ref. No.
1	F4232	42	1	14	F4127	42	8
2	F3220	42	2	15	F4235	42	4
3	F3917	44	1	16	F4233	44	3
4	F2936	44	2	17	F4316	44	4
5	F4398	42	11	18	SI-51	44	10
8	F4019	42	12	19	F1213	44	8
9	H919	42	13	20	F1713	44	13
10	F2551	42	14	21	F3179	44	12
11	F1717	42	23	22	E1335	44	7
12	F4323	42	5	23	F1792	44	6
13	F4129	42	10				

PETROL TANK — GROUP 12

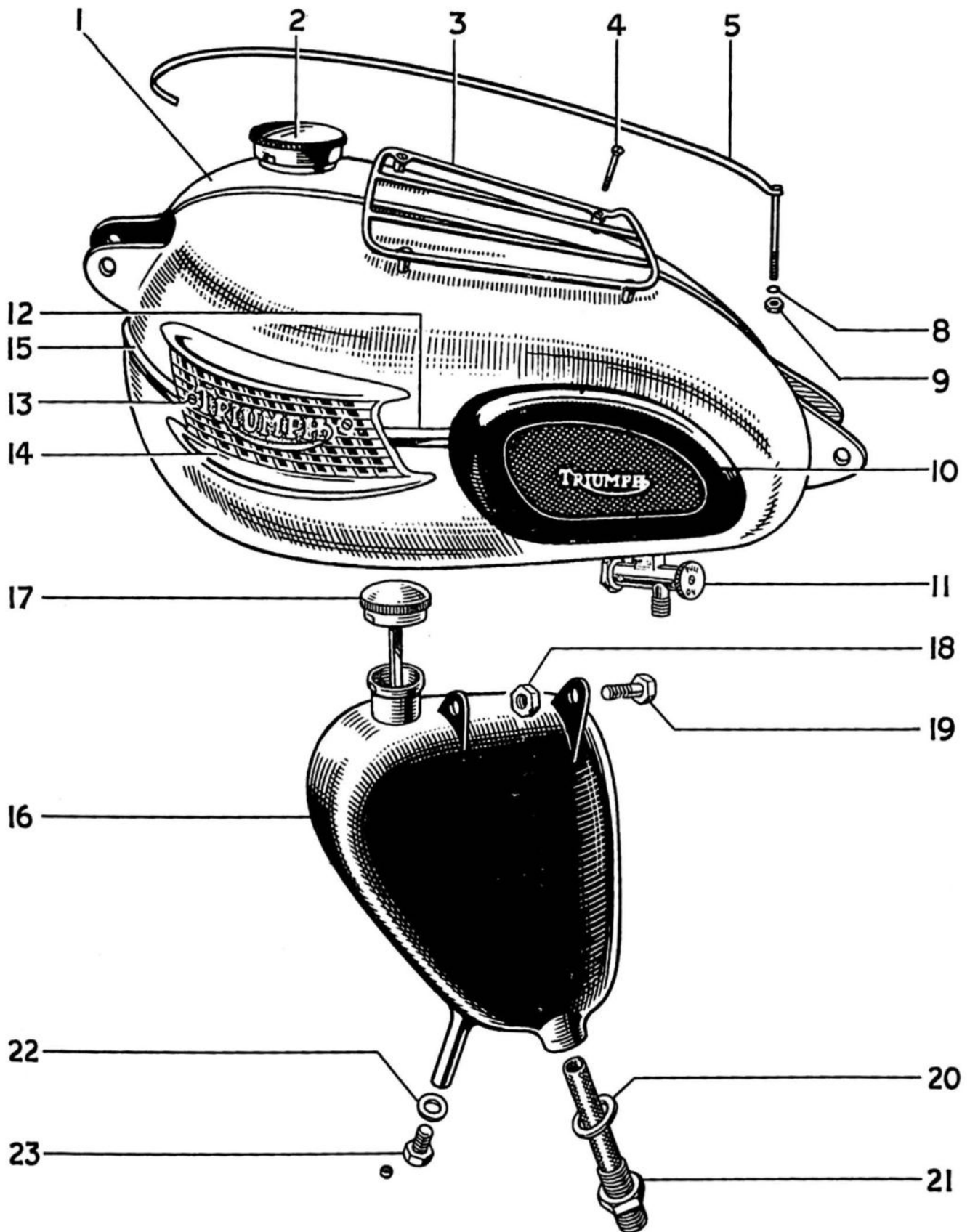

FIG. 14 PETROL AND OIL TANKS

GROUP 12 — PETROL TANK

GROUP 13 — OIL TANK

GROUP 14 — TOOL KIT

REF. No.	PART No.	DESCRIPTION	QUANTITY
PARCEL GRID			
1	F3917	Grid, petrol tank parcel	1
2	F2936	Screw, grid to tank, 1 $\frac{1}{8}$ " U.H.	4
OIL TANK—GROUP 13			
3	F4233	Tank, oil	1
4	F4316	CAP, OIL FILLER	1
5	F4047	Washer, cap joint	1
6	F1792	Plug, oil drain	1
7	E1335	Washer, copper drain plug	1
8	F1213	Bolt, tank to top bracket, $\frac{11}{16}$ " U.H.	2
9	S26-3	Washer, spring	2
10	S1-51	Nut, tank bolt	2
11	T1203	Pipe, tank vent (flexible)	1
OIL FILTER AND PIPES			
12	F3179	Filter, oil tank	1
13	F1713	Washer, filter to tank	1
14	F3655	Pipe, oil feed top half	1
15	F3182	Nut, pipe to filter union	1
16	E3853	Junction block, oil pipes to engine	1
17	E3763	Washer, junction block to crankcase	1
18	E1310	Nut, junction block stud	1
19	S25-3	Washer, plain	1
20	MF119/20	Connection, feed and return pipes (rubber)	2
21	E3383	Connection, rocker oil feed pipe (rubber)	1
TOOLKIT—GROUP 14			
22	F4319	Tooltray, rubber moulded	1
23	D360	Spanner, open ended, $\frac{1}{8}$ " x $\frac{5}{16}$ " Whit.	1
24	NA55	Spanner, open ended, $\frac{1}{4}$ " x $\frac{5}{16}$ " Whit.	1
25	DA16	Spanner, open ended, $\frac{3}{8}$ " x $\frac{7}{16}$ " Whit.	1
26	D370	Spanner, closed, $\frac{3}{16}$ " x $\frac{1}{4}$ " Whit.	1
27	PA57	Spanner, closed, $\frac{1}{2}$ " x $\frac{9}{16}$ " Whit.	1
28	D311	Spanner, closed, $\frac{5}{8}$ " x $\frac{11}{16}$ " Whit.	1
29	D362	Spanner, "C" and tappet key	1
30	DA50/1	Extractor, clutch centre	1
31	D87	Spanner, box sparking plug	1
32	D363	Tommybar, tyre lever and screwdriver	1
33	D364	Clutch key and tyre lever	1
34	D336	Screwdriver, Phillips No. 3	1
35	400935	Screwdriver, ignition and feeler gauge	1
36	D296	Inflator, tyre (12" long)	1

TOOLKIT — GROUP 14

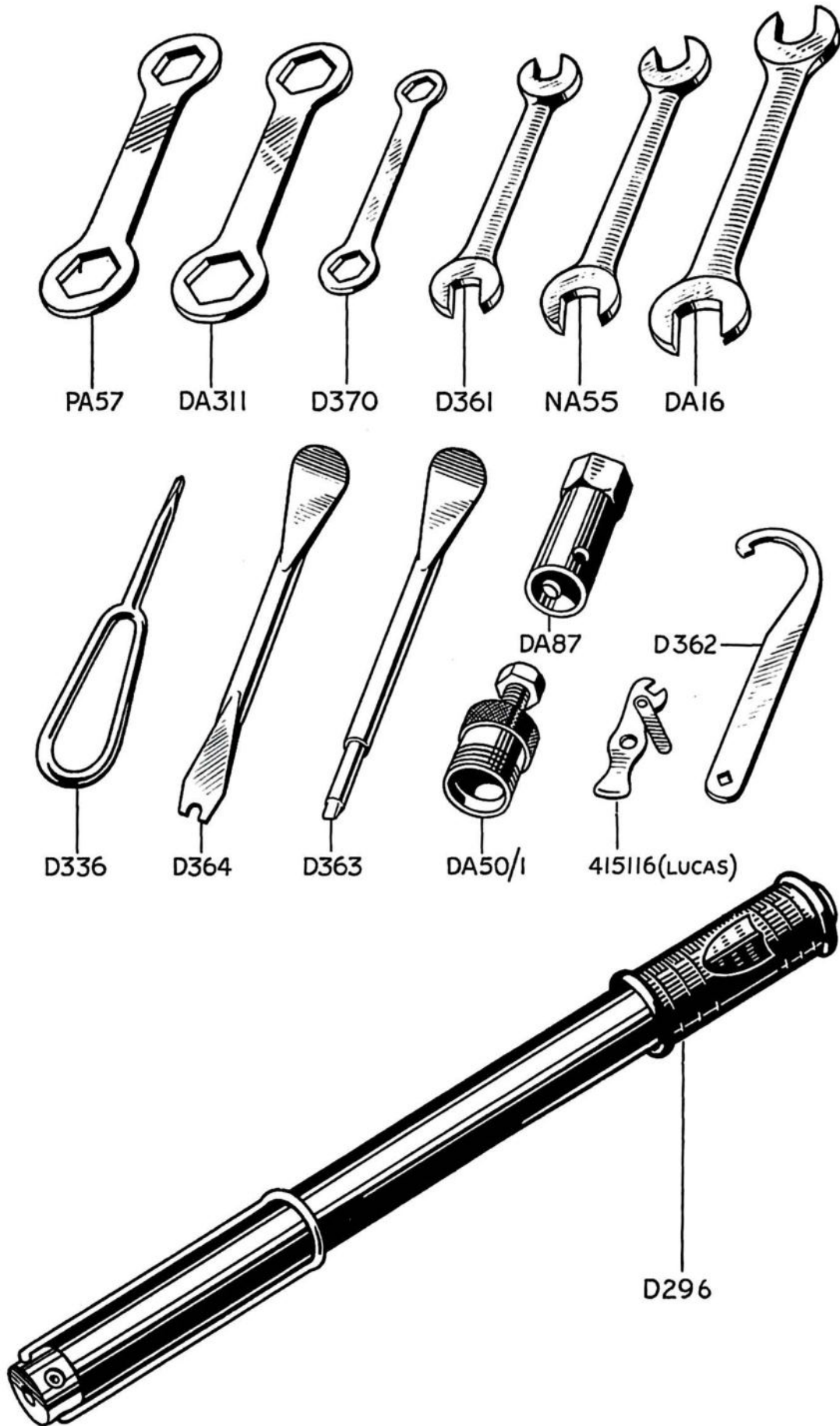

FIG. 15 TOOLKIT

GROUP 15 — TWINSEAT

REF. No.	PART No.	DESCRIPTION	QUANTITY
TWINSEAT—GROUP 15			
1	F4360	TWINSEAT C/W SAFETY STRAP (EXPORT)	A
2	F4239	TWINSEAT	1
3	F4242	Rubber pad, for battery	1
4	F4361	Strap assembly (EXPORT)	A
5	F4365	Screw, strap to seat (4 off)	A
6	F4244	Cover, twinseat c/w clips	1
7	66/4	Clip, cover to pan	as required
8	F4222	Hinge, twinseat	2
9	DS57	Bolt, hinge to seat, $\frac{7}{16}$ " U.H.	4
10	S26-2	Washer, spring	4
11	D374	Wire, check	1
12	F4325	Screw, check wire to seat	1
13	F4226	Plunger, seat catch	1
14	F4228	Spring, seat catch	1
15	E1719A	Washer, plain	1
16	—	Split pin, $\frac{3}{32}$ " x $\frac{3}{4}$ "	1
17	F4227	Knob, seat catch	1

INDEX TO FIG. 16

Illust. No.	Part No.	Page No.	Ref. No.	Illust. No.	Part No.	Page No.	Ref. No.
1	F4239	46	2	8	DS57	46	9
2	F4361	46	4	9	F4227	46	17
3	F4365	46	5	10	F4226	46	13
4	F4242	46	3	11	F4228	46	14
5	D374	46	11	12	E1719A	46	15
6	F4325	46	12	13	$\frac{3}{32}$ " x $\frac{3}{4}$ " Split pin	46	16
7	F4222	46	6				

TWINSEAT — GROUP 15

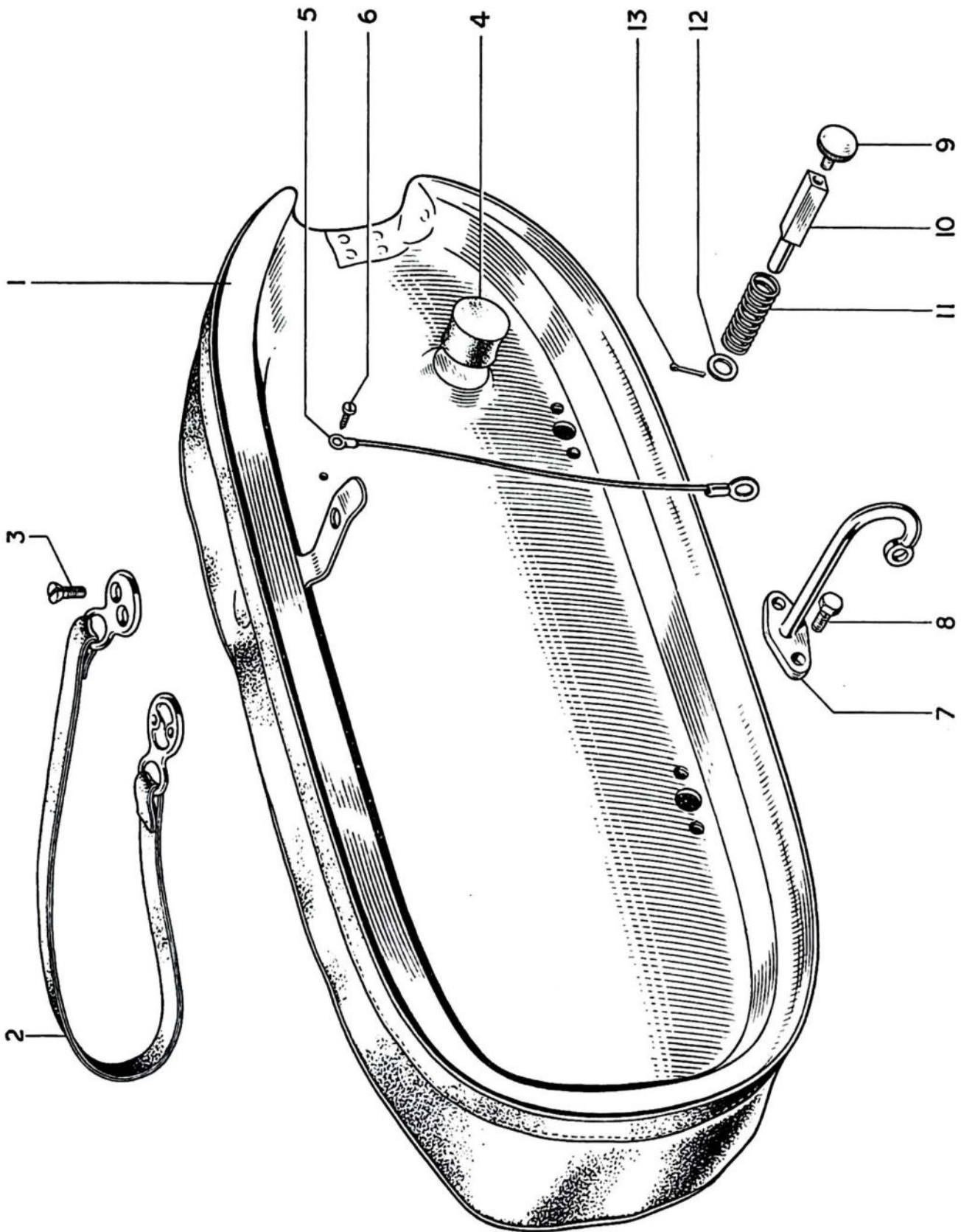

FIG. 16 TWINSEAT AND FITTINGS

GROUP 16 — HANDLEBAR

REF. No.	PART No.	DESCRIPTION	QUANTITY
----------	----------	-------------	----------

HANDLEBAR—GROUP 16

1	H1176	HANDLEBAR C/W CONTROLS	1
2	H1131	Handlebar	1
3	H230	Grip, handlebar L.H. rubber	1

THROTTLE CONTROL

4	H697	TWISTGRIP ASSEMBLY	1
5	H698	Head assembly, twistgrip	1
6	H665	Screw, friction adjuster	1
7	H685	Spring, adjuster screw	1
8	H686	Spring, friction	1
9	H234	Thimble, throttle cable	1
10	H237	Grubscrew, twistgrip	1
11	H700	Sleeve, twistgrip	1
12	H233	Plate, sleeve retaining	2
13	H232	Circlip, sleeve retaining	1
14	H230	Grip, twistgrip rubber	1

FRONT BRAKE CONTROL

15	18/886	LEVER ASSEMBLY, FRONT BRAKE	1
16	18/535	Lever only, R.H.	1
17	18/890	Bracket, lever fulcrum	1
18	18/838	Screw, adjuster	1
19	18/839	Nut, thumb	1
20	12/044	Clamp, lever bracket	1
21	11/014	Screw, bracket to clamp	2
22	18/087	Screw, lever fulcrum	1
23	18/053	Nut, fulcrum screw	1
24	18/880	Nipple, slotted barrel	1

INDEX TO FIG. 17

Illust. No.	Part No.	Page No.	Ref. No.	Illust. No.	Part No.	Page No.	Ref. No.
1	H1131	48	2	11	61/004	50	7
2	H230	48	3	12	18/087	50	8
3	H698	48	5	13	18/053	50	9
4	H234	48	9	14	18/886	48	15
5	H700	48	11	15	H689	59	22
6	H233	48	12	16	31563A	59	20
7	H232	48	13		863082	59	21
8	18/528	50	2	17	18/839	50	5
9	18/892	50	3	18	18/834	50	4
10	H668	50	6				

HANDLEBAR — GROUP 16

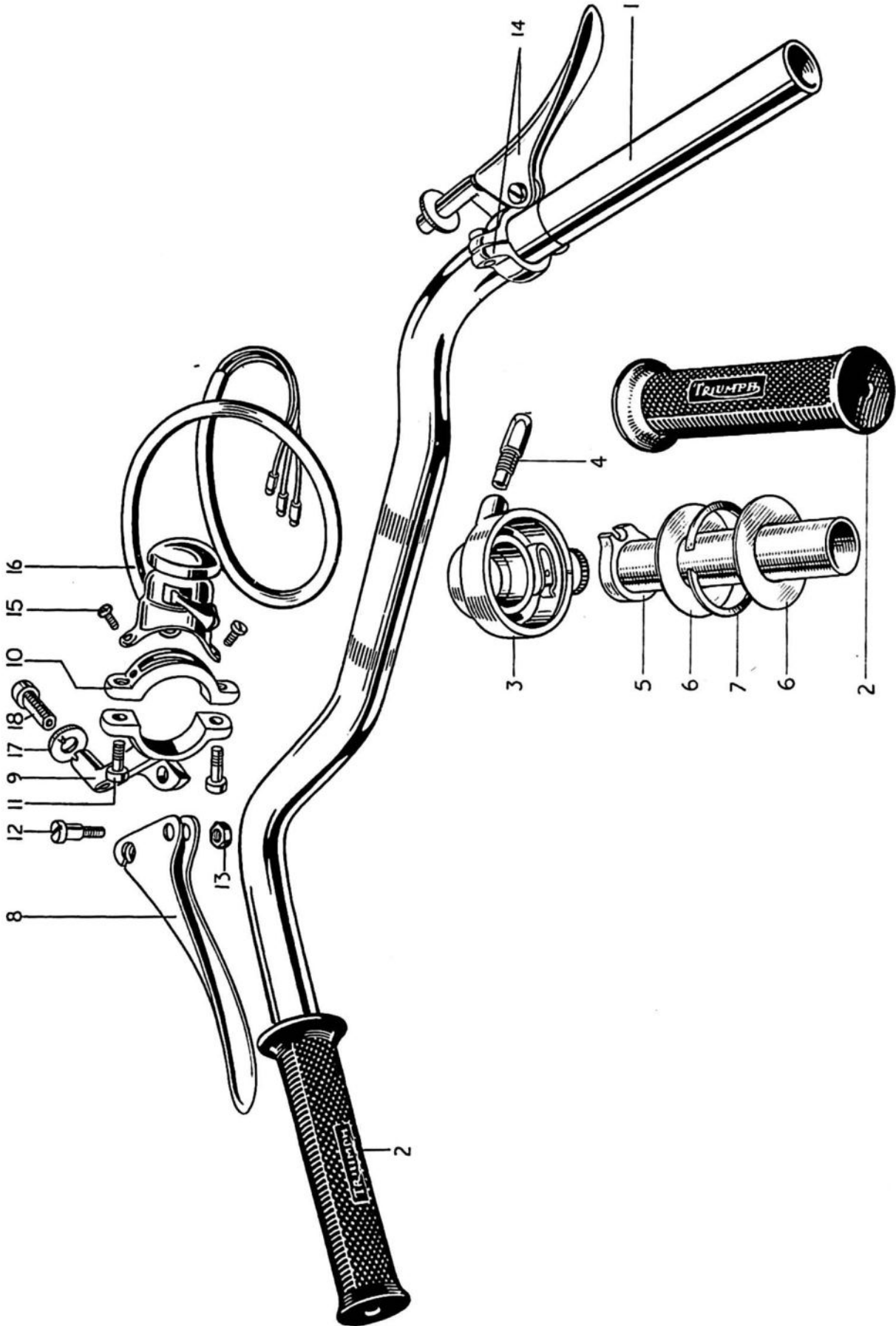

FIG. 17 HANDLEBAR AND CONTROLS

GROUP 16 — HANDLEBAR
GROUP 17 — CONTROL CABLES

REF. No.	PART No.	DESCRIPTION	QUANTITY
CLUTCH CONTROL			
1	18/894	LEVER ASSEMBLY, CLUTCH	1
2	18/528	Lever only, L.H.	1
3	18/892	Bracket, lever fulcrum	1
4	18/838	Screw, adjuster	1
5	18/839	Nut, thumb	1
6	H668	Clamp, lever bracket	1
7	61/004	Screw, bracket to clamp	2
8	18/087	Screw, lever fulcrum	1
9	18/053	Nut, fulcrum screw	1
10	18/880	Nipple, slotted barrel	1
CONTROL CABLES—GROUP 17			
11	XA69	Clip, cables to frame	as required
THROTTLE CABLE			
12	D383	CABLE ASSEMBLY, THROTTLE	1
13	D383W	Wire only, throttle	1
14	D383C	Casing only, throttle	1
15	D101	Ferrule, throttle casing	3
16	H670	Guide tube, throttle wire	1
17	D83	Nipple, twistgrip end	1
18	D104	Adjuster assembly	1
19	6/132A	Ferrule, at carburetter	1
20	NS191	Nipple, at carburetter	1
FRONT BRAKE CABLE			
21	D367	CABLE ASSEMBLY, FRONT BRAKE	1
22	D367W	Wire only, front brake	1
23	D367C	Casing only, front brake	1
24	D103	Ferrule, casing	2
25	D368	Nipple, lever end	1
26	W593	Fork end, lower	—
CLUTCH CABLE			
27	D366	CABLE ASSEMBLY, CLUTCH	1
28	D366W	Wire only, clutch	1
29	D366C	Casing only, clutch	1
30	D103	Ferrule, casing	2
31	D368	Nipple, lever end	1
32	DS73	Nipple, gearbox end	1

PROPRIETARY GROUP

Ancillary equipment which is fitted to our motor cycles is of the highest quality and is guaranteed by the manufacturers and not by ourselves. Any repairs or claims should be made to the actual maker who will always give owners every possible assistance. The following are the addresses of the various manufacturers :

CARBURETTERS	Messrs. Amal Ltd., Holdford Road, Witton, Birmingham, 6.
		The S.U. Carburetter Co., Ltd., Wood Lane, Erdington, Birmingham, 24.
CHAINS	The Renold and Coventry Chain Co. Ltd., Wythenshawe, Manchester.
ELECTRICAL EQUIPMENT	...	Messrs. J. Lucas, Ltd., Gt. Hampton Street, Birmingham, 18.
SPARKING PLUGS	Champion Sparking Plug Co. Ltd., Feltham, Middlesex.
		K.L.G. Sparking Plugs Ltd., Cricklewood Works, London, N.W.2.
		Lodge Plugs Ltd., Rugby, Warwickshire.
SPEEDOMETERS	Messrs. Smiths Motor Accessories Ltd., Cricklewood Works, London, N.W.2.
SUSPENSION UNITS	Messrs. Girling Ltd., Kings Road, Tyseley, Birmingham, 11.
TYRES	Dunlop Rubber Co. Ltd., Fort Dunlop, Birmingham, 24.

GROUP 18 — CARBURETTER

REF. No.	PART No.	DESCRIPTION	QUANTITY
CARBURETTER—GROUP 18			
1	375/23	CARBURETTER, COMPLETE	1
2	375/004	Body, mixing chamber	1
3	375/058	Block, jet	1
4	375/067	Washer, jet block	1
5	376/070	Peg, jet block locating	1
6	375/107	Top, mixing chamber	1
7	375/065	Cap ring, mixing chamber	1
8	4/276	Spring, mixing chamber cap	1
9	4/241	Screw, cap spring	1
10	4/137A	Screw, plug	1
11	375/060	Valve, throttle (3½" cutaway)	1
12	375/061	Spring, throttle valve	1
13	375/063	Needle, throttle slide	1
14	4/230	Clip, needle	1
15	376/072	Jet, needle (.105)	1
16	376/100	Jet, main (110)	1
17	376/100	Jet, main (120, less air filter)	A
18	376/073	Holder, main jet	1
19	376/074	Washer, main jet holder	1
20	376/075	Nut, main jet cover	1

INDEX TO FIG. 18

Illust. No.	Part No.	Page No.	Ref. No.	Illust. No.	Part No.	Page No.	Ref. No.
1	4/137A	52	10	16	376/073	52	18
2	4/276	52	8	17	376/100	52	16
3	375/065	52	7	18	376/075	52	20
4	375/107	52	6	19	375/058	52	3
5	375/061	52	12	20	376/091	54	14
6	375/060	52	11	21	F4308	42	25
7	375/063	52	13	22	376/093	54	22
8	375/004	52	2	23	E3815	54	29
9	244/765	54	23	24	229/048	54	24
10	332/017	54	4	25	376/088	54	12
11	376/070	52	5	26	376/077	54	19
12	376/072	52	15	27	376/079	54	21
13	376/068	54	6	28	376/094	54	10
14	376/076	54	1	29	376/083	54	8
15	376/095	54	2	30	376/089	54	11

CARBURETTER — GROUP 18

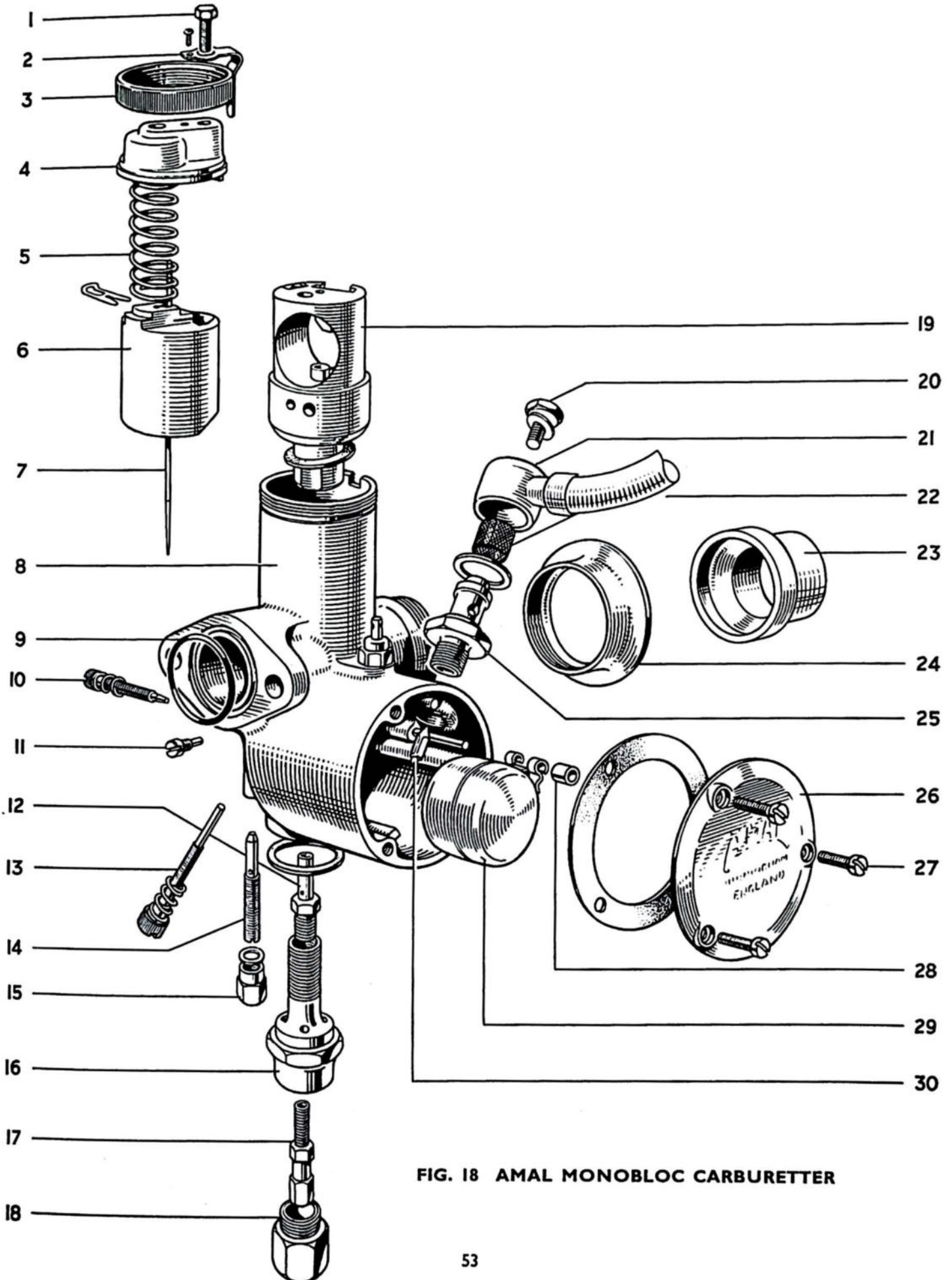

FIG. 18 AMAL MONOBLOC CARBURETTER

GROUP 18 — CARBURETTER

GROUP 19 — AIR FILTER

GROUP 20 — CHAINS

REF. No.	PART No.	DESCRIPTION	QUANTITY
1	376/076	Jet, pilot (25)	1
2	376/095	Nut, pilot jet cover	1
3	116/162	Washer, cover nut	1
4	332/017	Screw, air adjusting	1
5	4/148	Spring, air adjusting screw	1
6	376/068	Screw, throttle stop	1
7	376/069	Spring, throttle stop screw	1
8	376/083	Float	1
9	376/085	Spindle, float hinge	1
10	376/094	Bush, float spindle	1
11	376/089	Needle, float	1
12	376/088	Seating, needle	1
13	14/175	Washer, banjo seating	1
14	376/091	Bolt, banjo	1
15	376/092	Washer, banjo bolt	1
16	376/086	Tickler	1
17	343/011	Body, tickler	1
18	376/087	Spring, tickler	1
19	376/077	Cover, float chamber	1
20	376/078	Washer, float chamber cover	1
21	376/079	Screw, float chamber cover	3
22	376/093	Filter, gauze	1
23	244/765	"O" ring, carburetter to manifold	1
24	229/048	Tube, air intake	A

AIR FILTER—GROUP 19

25	F4218	Air filter	1
26	DS57	Bolt, filter to frame, $\frac{7}{16}$ " U.H.	2
27	S25-43	Washer, plain	2
28	F879	Nut, filter bolt	2
29	E3815	Connection, rubber, carburetter to filter	1
30	F3859	Clip, connection to carburetter	1

CHAINS—GROUP 20

31	D358	Chain, primary, 78L x $\frac{3}{8}$ " x $\frac{1}{4}$ " Duplex	1
32	D304	Chain, rear, 100L x $\frac{5}{8}$ " x $\frac{3}{8}$ "	1
33	110056/59	Kit, rear chain spares	1

ELECTRICAL EQUIPMENT — GROUP 21

REF. No.	PART No.	DESCRIPTION	QUANTITY
ELECTRICAL EQUIPMENT—GROUP 21			
ALTERNATOR			
1	413506	Rotor	1
2	E3851	Key, rotor to shaft	1
3	468973	STATOR, complete	1
4	862898	Cable, stator output	1
5	E3811	Stud, stator to crankcase, 3 ⁵ / ₁₆ " O.A.	3
6	E3810	Distance piece, stator	3
7	S25-3	Washer, plain	3
8	SI-51	Nut, stator fixing	3
9	E3764	Ring, cable sealing (rubber)	1
10	E3765	Nut, cable sealing	1
11	E1509	Clip, cable to crankcase	1
12	T361	Bolt, clip, 1/4" U.H.	1
AMMETER			
13	36189A	Ammeter, type BM4	1
BATTERY			
14	PUZ7E-10	Battery	1
15	F4219	Carrier, battery	1
16	DS57	Bolt, battery carrier, 7/16" U.H.	3
17	F879	Nut, carrier bolts	3
18	S25-43	Washer, plain, bottom nut	1
COIL			
19	45077A	Coil, 6 volt MA6	1
20	DS57	Bolt, coil to frame, 7/16" U.H.	2
21	F879	Nut, coil bolt	2
22	E2312	Washer, shakeproof	2
23	422567	Grommet, rubber	1
24	421863	Clip, cable contact	1
DISTRIBUTOR			
25	40573A	DISTRIBUTOR	1
26	425049	Cap assembly	1
27	404435	Brush and spring	1
28	421554	Grommet, rubber cable	3
29	421863	Clip, cable contact	3
30	423486	Rotor	1
31	423110	Bush, shaped insulating	1
32	423108	Connector, terminal to condenser	1
33	423109	Bush, insulating	1
34	421748	Condenser	1
35	421569	Cover, rubber condenser	1
36	425219	Contact set	1
37	423113	Plate, contact breaker base	1

GROUP 21 — ELECTRICAL EQUIPMENT

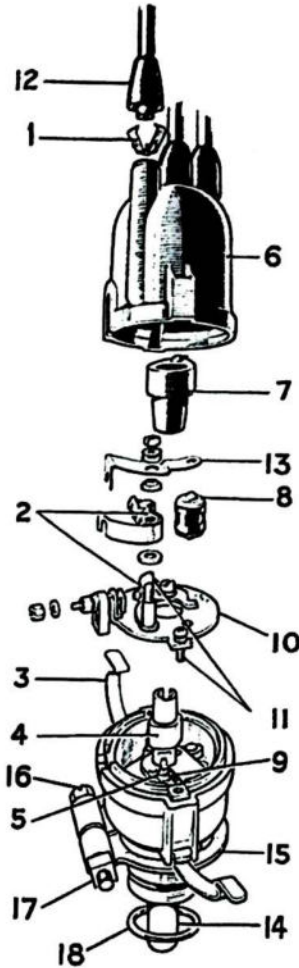

FIG. 19 LUCAS DISTRIBUTOR TYPE 18D2

INDEX TO FIG. 19

<i>Illust. No.</i>	<i>Part No.</i>	<i>Page No.</i>	<i>Ref. No.</i>	<i>Illust. No.</i>	<i>Part No.</i>	<i>Page No.</i>	<i>Ref. No.</i>
1	421863	55	29	10	423113	55	37
2	425219	55	36	11	425243	57	8
3	424158/S	57	6	12	421554	55	28
4	424972	57	1	13	423108	55	32
5	421056/S	57	3	14	424967	57	5
6	425049	55	26	15	E3825	57	10
7	423486	55	30	16	112917	57	13
8	421748	55	34	17	173857	57	15
9	422655/S	57	2	18	E3309	57	9

ELECTRICAL EQUIPMENT — GROUP 21

REF. No.	PART No.	DESCRIPTION	QUANTITY
1	424972	Cam	1
2	422655/S	Spring set	1
3	421056/S	Weight set	1
4	424974	Cup, thrust, sealing	1
5	424967	Shaft and action plate	1
6	424158/S	Clip, cap retaining	1
7	423571	Bush, shaft	1
8	425243	Sundry parts set	1
9	188639	Ring, sealing	1
10	E3825	Plate, distributor clamp	1
11	DS57	Bolt, clamp plate to crankcase, $\frac{7}{16}$ " U.H.	1
12	S25-3	Washer, plain	1
13	112917	Bolt, distributor clamp	1
14	185051	Washer, spring	1
15	173857	Nut, clamp bolt	1
16	E3853	Sheath, distributor leads	1

HORN

17	70148A	Horn	1
18	701851	Bracket, triangular	2
19	H1172	Bracket, angle (to handlebar "U" bolt nuts)	1
20	142689	Screw, horn bracket	2
21	185051	Washer, bracket screw	2

HEADLAMP

22	51860A	HEADLAMP ASSEMBLY	1
23	553248	Rim, front	1
24	555309	Glass and reflector light unit	1
25	504665	Fixing wire, light unit	6
26	373	Bulb, prefocus 30/24W	1
27	554602	Adaptor, bulb	1
28	988	Bulb, pilot 3W	1
29	554710	Bulbholder, pilot	1
30	553267	Ring, lamp fixing	1
31	144921	Screw, rim fixing	1
32	554408	Plate, rim fixing	1
33	H689	Screw, fixing ring, $\frac{1}{4}$ " U.H.	2
34	H690	Nut, fixing screw	2

GROUP 21 — ELECTRICAL EQUIPMENT

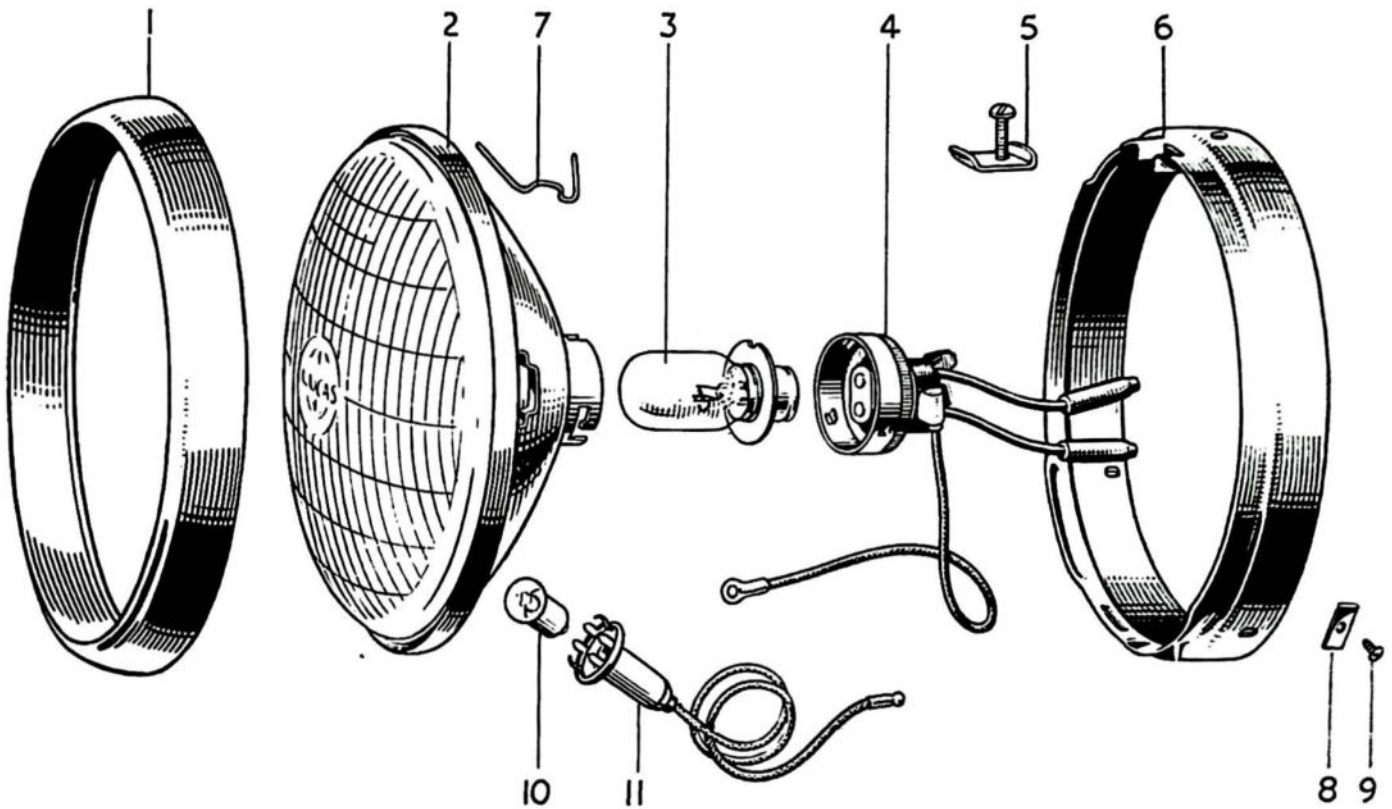

FIG. 20 LUCAS HEADLAMP TYPE MCF700P

INDEX TO FIG. 20

<i>Illust. No.</i>	<i>Part No.</i>	<i>Page No.</i>	<i>Ref. No.</i>	<i>Illust. No.</i>	<i>Part No.</i>	<i>Page No.</i>	<i>Ref. No.</i>
1	553248	57	23	6	553267	57	30
2	555309	57	24	7	504665	57	25
3	373	57	26	8	H690	57	34
4	554602	57	27	9	H689	57	33
5	144921	57	31	10	988	57	28
	554408	57	32	11	554710	57	29

ELECTRICAL EQUIPMENT — GROUP 21

REF. No.	PART No.	DESCRIPTION	QUANTITY
REAR LAMP			
1	53432B	LAMP, STOP AND TAIL	1
2	573839	Lens	1
3	575200	Window	1
4	575208	Gasket, lens seating	1
5	575219	Nut, lens retaining	2
6	576002	Base assembly	1
7	575209	Bulbholder	1
8	575207	Grommet, bulbholder	1
9	573828	Contact assembly	1
10	573825	Grommet, cable	1
11	384	Bulb, 6/18W, offset pin	1
RECTIFIER			
12	47111A	Rectifier	1
13	F3600	Nut, rectifier to frame	1
LIGHTING AND IGNITION SWITCH			
14	31443E	LIGHTING AND IGNITION SWITCH	1
15	318323	Grommet, for key	1
16	318241	Key	1
17	319333	Screw, for knob	1
18	318346	Knob	1
19	318343	Plate, index	1
HORN PUSH AND DIP SWITCH			
20	31563A	Horn push and dip switch	1
21	863082	Cable, dip switch	1
22	H689	Screw, switch to clutch lever, $\frac{1}{4}$ " U.H.	2
STOP LAMP SWITCH			
23	31688A	Switch, stop lamp	1
24	360363	Cover, rubber terminal	1
WIRING HARNESS			
25	838601	Wiring harness	1
26	862566	Grommet, at rectifier	1
27	838604	Lead, twin stop-tail lamp	1
28	900288	Connector, snap	as required
29	900269	Nipple, snap connector	as required

GROUP 22 — SPARKING PLUGS
GROUP 23 — SPEEDOMETER
GROUP 24 — SUSPENSION UNITS

REF. No.	PART No.	DESCRIPTION	QUANTITY
SPARKING PLUGS—GROUP 22			
1	NA10	Plug, sparking (Champion)	A
2	HLN	Plug, sparking (Lodge)	A
3	FE100 (3 point)	Plug, sparking (K.L.G.)	A
4	D297	Cover and suppressor, plug	2
SPEEDOMETER—GROUP 23			
5	S467/227	Speedometer head M.P.H.	1
6	S467/231N	Speedometer head K.P.H.	A
7	P53279/1	BULB HOLDER C/W BULB	1
8	P52305	Bulb only	1
9	P22469	Rubber ring, speedometer head	1
10	25578/2	Clamp bar	1
11	NI253	Nut, clamp bar	2
12	D356	Cable, speedometer drive, 58" long	1
SUSPENSION UNITS—GROUP 24			
13	SB3/242	SUSPENSION UNIT, COMPLETE	2
14	9054/151	Dirt shield, outer	2
15	9054/171	Retainer, split	4
16	9054/47	Dirt shield, inner	2
17	9054/280	Spring, 100 lbs. rate	2
18	9054/316A	Bush and sleeve, bonded	4
19	E2113	Bolt, unit fixing, 1 $\frac{5}{16}$ " U.H.	4
20	F2184	Washer, bottom bolts	2
21	P0172A	Nut, fixing bolt	4
22	S26-1	Washer, spring	4

SUSPENSION UNITS — GROUP 24

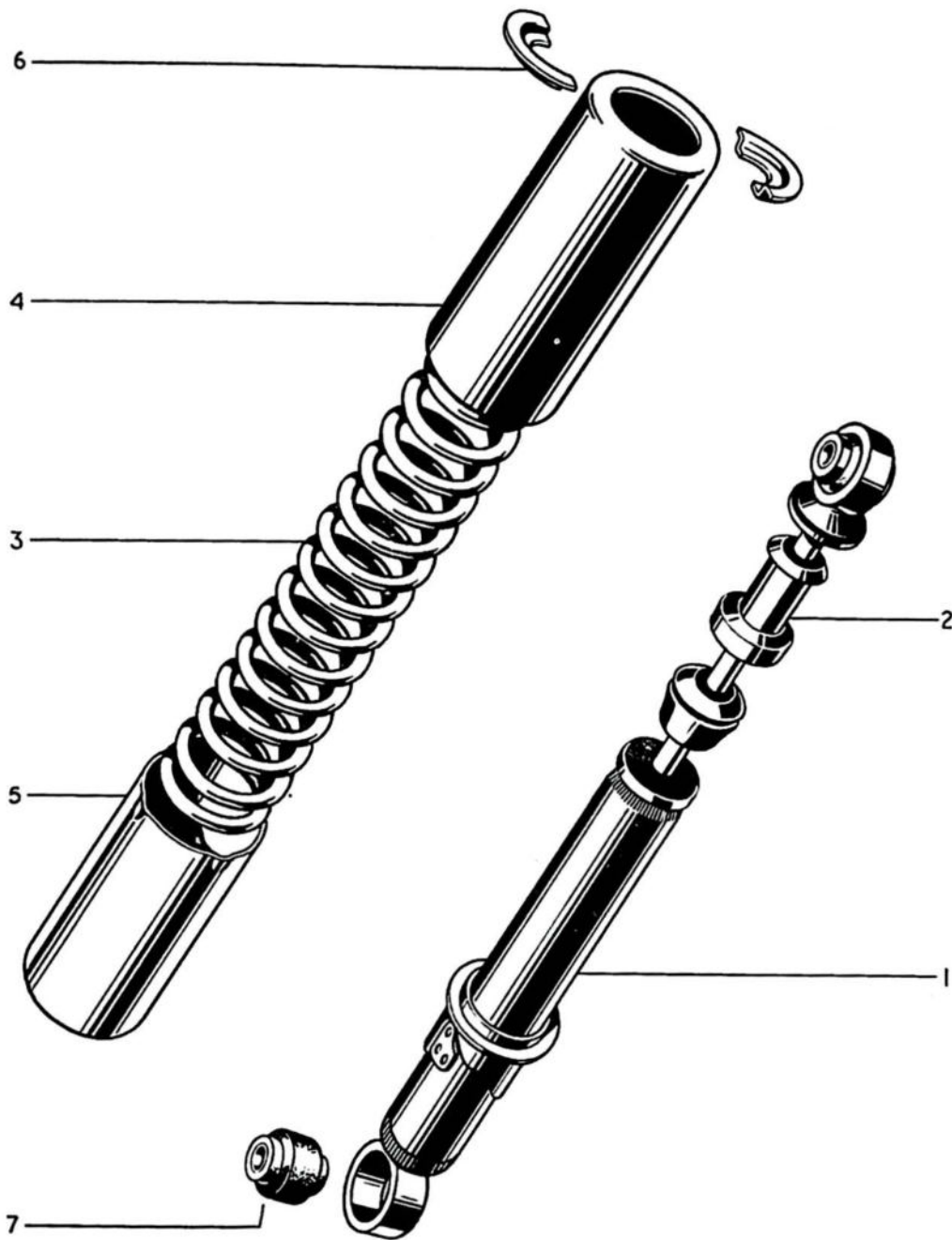

FIG. 21 GIRLING SUSPENSION UNIT

INDEX TO FIG. 21

Illust. No.	Part No.	Page No.	Ref. No.	Illust. No.	Part No.	Page No.	Ref. No.
1	SB3/242	60	13	4	9054/151	60	14
2	Not supplied separately			5	9054/47	60	16
3	9054/280	60	17	6	9054/171	60	15
				7	9054/316A	60	18

GUARANTEE

WE give the following guarantee with our motor cycles, motor cycle combinations and sidecars. This guarantee is given in place of any implied conditions or warranties or any liabilities whatsoever statutory or otherwise ; no guarantee except that hereinafter contained and no conditions or warranty whatsoever statutory or otherwise is given or is to be implied, nor are we to be under any liability whatsoever except under the guarantee hereinafter contained. Any statement, description, condition or representation contained in any catalogue, advertisement, leaflet or other publication shall not be construed as enlarging, varying or overriding anything herein contained. In the case of machines (a) which have been used for "hiring out" purposes or (b) any motor cycle and/or sidecar used for any dirt tracks, cinder tracks or grass track racing or competitions (or any competition of any kind within an enclosure for which a charge is made for admission to take part in or view the competition) or (c) machines from which the trade mark, name or manufacturing number has been altered or removed or (d) any machines in which parts have been used not supplied by or approved by the motor cycle manufacturer, or (e) any machine from which the silencing system as fitted by the manufacturer has been partially or wholly removed or interfered with, no guarantee, condition or warranty of any kind statutory or otherwise is given or is to be implied nor are we to be under any liability whatsoever in respect of any such machine.

We guarantee, subject to the conditions mentioned below, that all precautions which are usual and reasonable have been taken by us to secure excellence of materials and workmanship, but this guarantee is to extend and be in force for six months only in the U.K. and ninety days overseas from date of purchase, or date of exchange in case of any part supplied by way of exchange as hereinafter provided, and damages for which we make ourselves responsible under this guarantee are limited to the free repair of or supply of a new part in exchange for the part of the motor cycle, motor cycle combination or sidecar which may have proved defective. We undertake, subject to the conditions mentioned below, to make good in manner aforesaid any part covered by this guarantee which has proved defective within the said period. We do not undertake to replace or refix, or bear the cost of replacing or refixing any such new part in the motor cycle, motor cycle combination or sidecar. As motor cycles, motor cycle combinations and sidecars are easily liable to derangement by neglect or misuse, this guarantee does not apply to defects caused by wear and tear, misuse or neglect.

The term "misuse" shall include amongst others the following acts :—

1. The attaching of a sidecar to a motor cycle in such a manner as to cause damage or calculated to render the latter unsafe when ridden.
2. The use of a motor cycle or of a motor cycle and sidecar combined, when carrying more persons or a greater weight than that for which the machine was designed by the manufacturers.
3. The attaching of a sidecar to a motor cycle by any form of attachment not provided, supplied, or approved by the manufacturers, or to a motor cycle which is not designed for such use.

We do not guarantee specialities such as tyres, saddles, chains, carburettors, electrical equipment, lamps, etc., or any accessories or component parts supplied to the order of the purchaser differing from those comprised in the standard specifications supplied with our motor cycles, motor cycle combinations or sidecars. As regards all such specialities, accessories or component parts, no guarantee, condition, or warranty of any kind statutory or otherwise is given or is to be implied, and we are to be under no liability whatsoever in respect thereof.

CONDITIONS OF GUARANTEE

If a defective part should be found in our motor cycles, motor cycle combinations or sidecars, or in any part supplied by way of exchange as before provided, it must be sent to us **CARRIAGE PAID**, and accompanied by an intimation from the owner that he desires to have it repaired or exchanged free of charge under our guarantee and he must also furnish us at the same time with the frame number of the machine, the date of purchase or the date when the alleged defective part was exchanged as the case may be.

Failing compliance with the above, such articles will lie here at **THE RISK OF THE OWNER**, and this guarantee and any implied guarantee, warranty or condition, shall not be enforceable.

REPAIRS

Any motor cycle, motor cycle combination or sidecar sent to us to be plated, enamelled or repaired will be repaired upon the following conditions, i.e., we guarantee that all precautions which are usual and reasonable have been taken by us to secure excellence of materials and workmanship, such guarantee to extend and be in force for three months only from the time such work shall have been executed, and this guarantee is in lieu and in exclusion of all conditions and warranties statutory or otherwise and all liabilities whatsoever and the damages recoverable are limited to the cost of any further work which may be necessary to amend and make good the work found to be defective.

NOTICE

We do not appoint agents for the sale on our behalf of our motor cycles or other goods, but we assign to motor cycle Dealer areas in which we supply to such Dealers exclusively for re-sale in such areas. No such Dealer is authorised to transact any business, give any warranty, make any representation or incur any liability on our behalf. All goods are offered for sale subject to the price ruling at time of delivery. We reserve the right to modify or deviate from the published specification.

INDEX

	<i>Page No.</i>
Group 1—CARTON PACKS	5
Group 2—ENGINE	8
Cylinder block	8
Pistons	8
Cylinder head and valve guides	8
Inlet manifold	8
Valve and springs	10
Rocker boxes and rocker gear	10
Rocker oil feed pipe	10
Crankshaft	12
Connecting rods	12
Crankcase	12
Crankcase fittings	14
Timing gears and camshafts	14
Tappets and push rods	16
Oil pump	16
Timing cover	16
Oil pressure release valve	16
Engine sprocket	17
Group 3—GEARBOX	18
Shafts and Gears	18
Gearbox bearings	18
Gearbox casing fittings	18
Gearchange mechanism	20
Inner cover and kickstarter	20
Outer cover and clutch lever	20
Gearchange and kickstart levers	22
Gearbox sprocket and cover plate	22
Clutch and shock absorber	22
Chaincase cover	25
Group 4—EXHAUST SYSTEM	25
Group 5—FRAME	26
Engine plates and studs	26
Engine torque stays	26
Swinging fork	27
Centre stand	27
Prop stand	27
Footrests	27
Brake pedal	28

Group 6—TELESCOPIC FRONT FORK	30
Steering races	33
Nacelle top and motifs	33
Group 7—FRONT WHEEL	34
Front brake	36
Group 8—REAR WHEEL	38
Rear brake	38
Speedometer drive	38
Chain adjusters	38
Group 9—FRONT MUDGUARD	39
Front stand	39
Front number plate	39
Licence holder	39
Group 10—REAR MUDGUARD AND PANELS	39
Rear mudguard	39
Rear panels	39
Rear number plate	40
Group 11—REAR CHAINGUARDS	40
Upper rear chainguard	40
Lower rear chainguard	40
Group 12—PETROL TANK	42
Petrol tap and pipe	42
Parcel grid	44
Group 13—OIL TANK	44
Oil filter and pipes	44
Group 14—TOOLKIT	44
Group 15—TWINSEAT	46
Group 16—HANDLEBARS	48
Throttle control	48
Front brake control	48
Clutch control	50

Group 17—CONTROL CABLES	50
--------------------------------	-----	-----	-----	-----	-----	-----	-----	-----	-----	----

PROPRIETARY FITTINGS

Group 18—CARBURETTER	52
-----------------------------	-----	-----	-----	-----	-----	-----	-----	-----	-----	----

Group 19—AIR FILTER	54
----------------------------	-----	-----	-----	-----	-----	-----	-----	-----	-----	----

Group 20—CHAINS	54
------------------------	-----	-----	-----	-----	-----	-----	-----	-----	-----	----

Group 21—ELECTRICAL EQUIPMENT	55
--------------------------------------	-----	-----	-----	-----	-----	-----	-----	-----	-----	----

Alternator	55
Ammeter	55
Battery	55
Coil	55
Distributor	55
Horn	57
Headlamp	57
Rear lamp	59
Rectifier	59
Switches	59
Wiring harness	59

Group 22—SPARKING PLUGS	60
--------------------------------	-----	-----	-----	-----	-----	-----	-----	-----	-----	----

Group 23—SPEEDOMETER	60
-----------------------------	-----	-----	-----	-----	-----	-----	-----	-----	-----	----

Group 24—SUSPENSION UNITS	60
----------------------------------	-----	-----	-----	-----	-----	-----	-----	-----	-----	----

INDEX TO ILLUSTRATIONS

	<i>Page No.</i>
Fig. 1. Inlet manifold	9
„ 2. Cylinder block and head	11
„ 3. Crankshaft and connecting rods	13
„ 4. Crankcase and covers	15
„ 5. Shaft and gears	19
„ 6. Gearbox inner cover	21
„ 7. Gearbox outer cover	23
„ 8. Clutch and shock absorber	24
„ 9. Frame and fittings	29
„ 10. Telescopic front fork	31
„ 11. Front wheel	35
„ 12. Rear wheel	37
„ 13. Rear mudguard, chainguard and panels	41
„ 14. Petrol and oil tanks	43
„ 15. Toolkit	45
„ 16. Twinseat	47
„ 17. Handlebar and controls	49
„ 18. Amal monobloc carburetter	53
„ 19. Lucas distributor, Type I8D2	56
„ 20. Lucas headlamp, Type MCF700P	58
„ 21. Girling suspension unit	61

To assist the owner and dealer in identifying requirements, this book contains numerous exploded views of the major assemblies. Each component part on the illustration is numbered, and by cross reference to the appropriate index, the part number of the component will be found. Against each part number a page and reference number is shown and by referring to the appropriate page, the full description of the part will be found against the reference number.

EXAMPLE

To find the part number of the cylinder head gasket :

1. Refer to the illustration index above, where it will be found that the engine is illustrated on page 11.
2. Note that the number of the gasket in the illustration is 38.
3. Refer to the index on page 11.
4. Note that illustration number 38 is part number E3769 listed on page 8, line 14.

*Tournez s'il vous plait.
Vease al dorso.
Bitte wenden.*