



September, 1958.

BRITCYCLE
www.britcycle.com.au

LIST No. 560
(ISSUE No. 2)

Spare Parts List

for

Handlebars and Controls

**All illustrations full size
(except Handlebar Assemblies)**

For Prices refer to Supplementary List No. 561

For Twist Grip Parts refer to List No. 521

GUARANTEE.—The Company take all possible reasonable care in the manufacture and the quality of their products. Purchasers are informed that, any part proved to be defective in manufacture or quality, and returned to the works within six months of its purchase new, will be replaced. The Company must respectfully point out however, that its responsibility and that of its agents, stockists and dealers, is limited to this Guarantee, and that they cannot under any circumstances, be held responsible for any loss or for any contingent or resulting liability arising through any defect. These conditions of sale and use also apply when the Company's products form part of the original equipment of machines purchased new.

1000/9/58. W.

Printed in England

www.britcycle.com.au

**AMAL LTD., HOLDFORD ROAD, WITTON,
BIRMINGHAM 6, ENGLAND**

'Phone : Birmingham, BIRchfields 4571.
(P.B.X. 6 lines)

Telegrams : "AMALCARB, 'PHONE.
BIRMINGHAM."

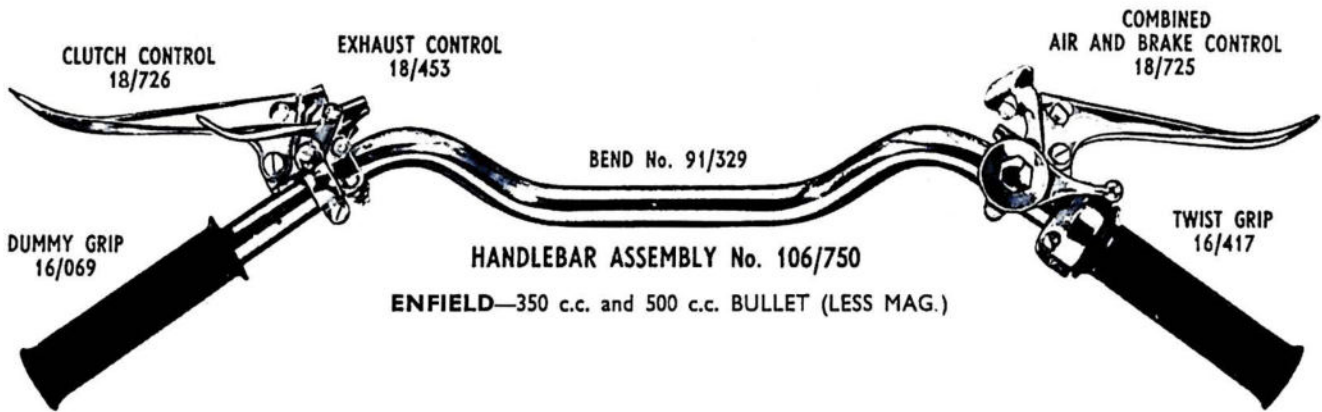
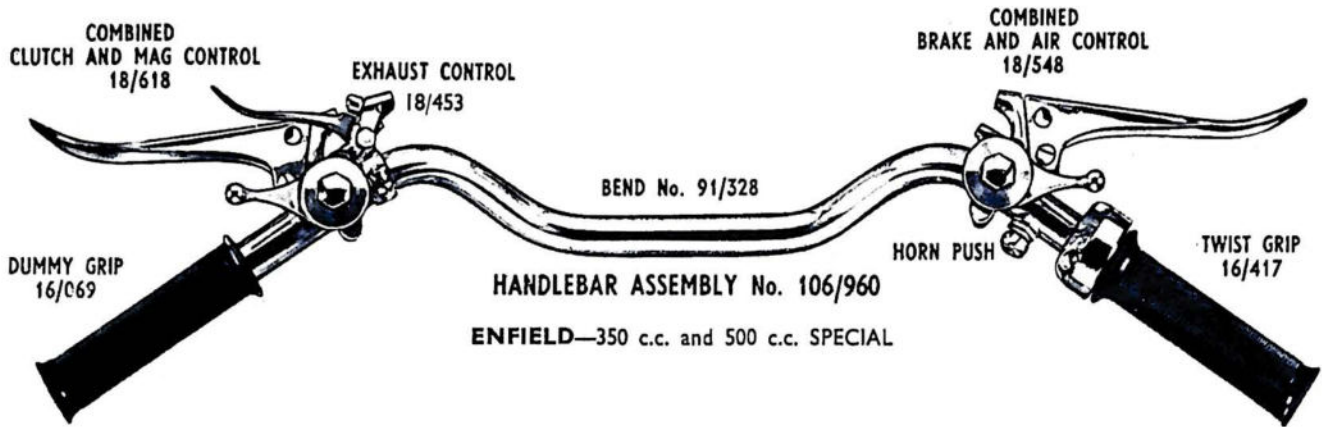
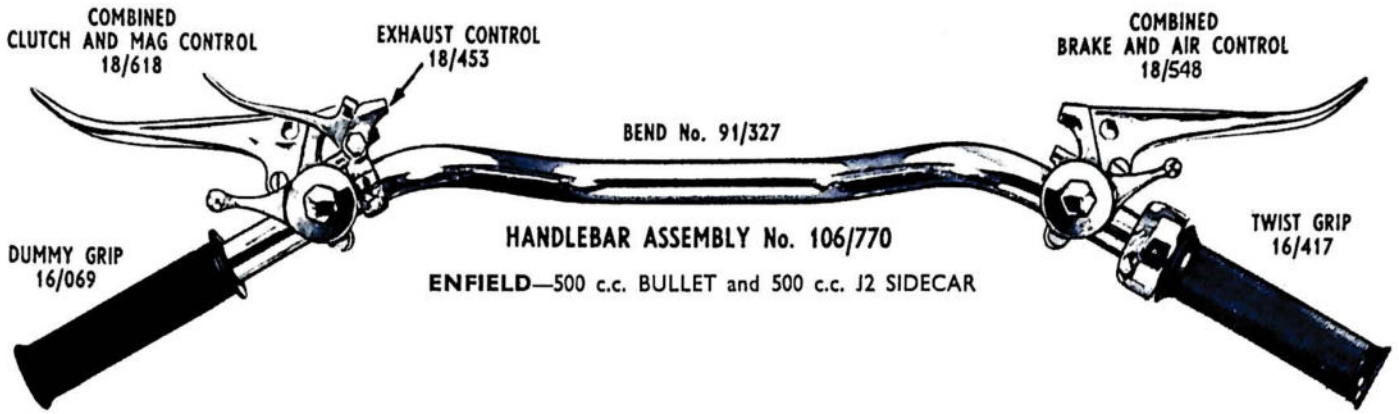

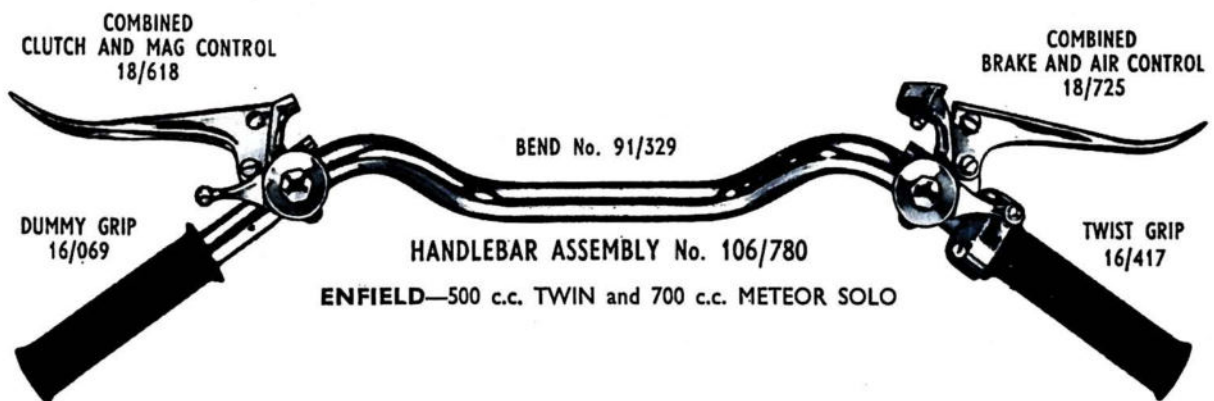
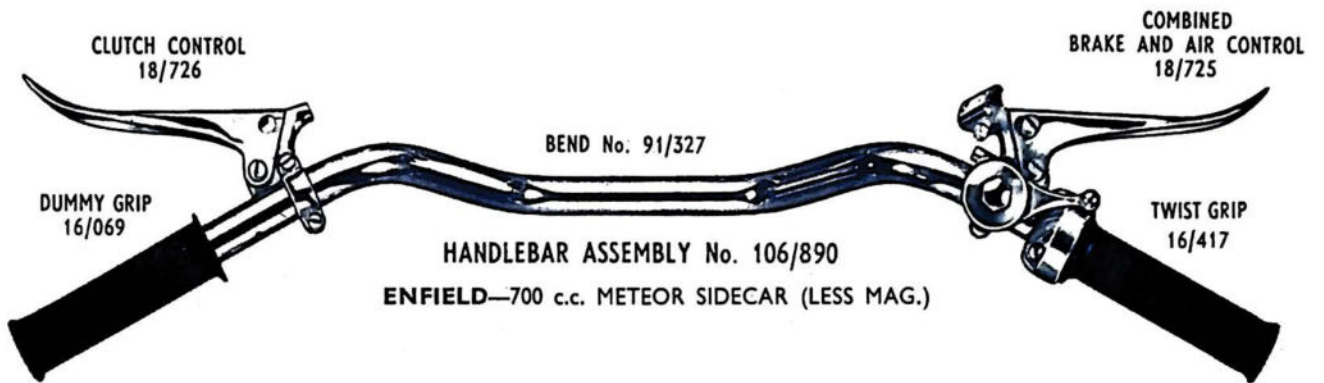
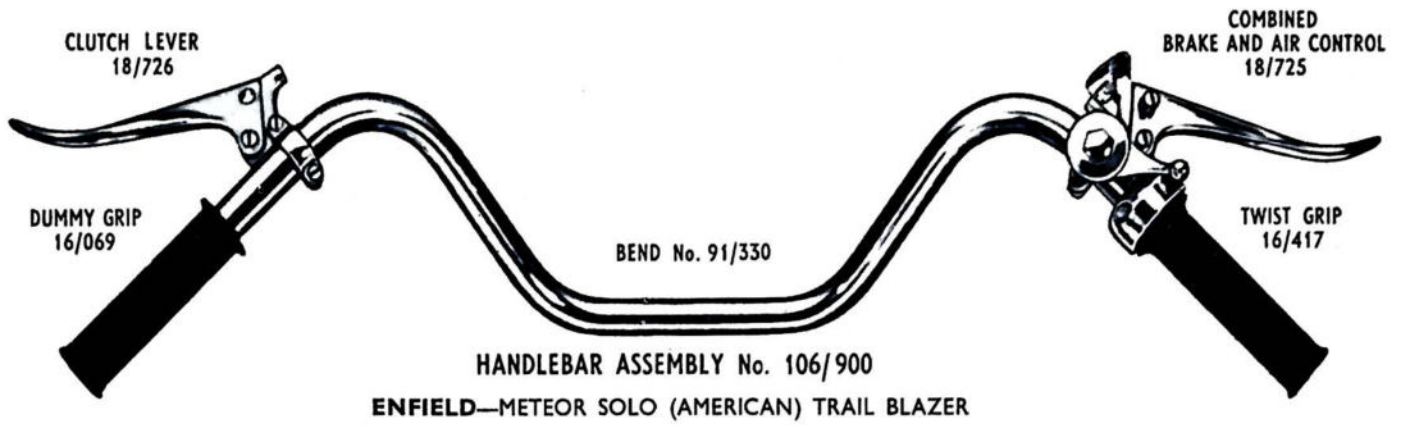

TWIST GRIP 16/417 NOW REPLACED BY 366/1

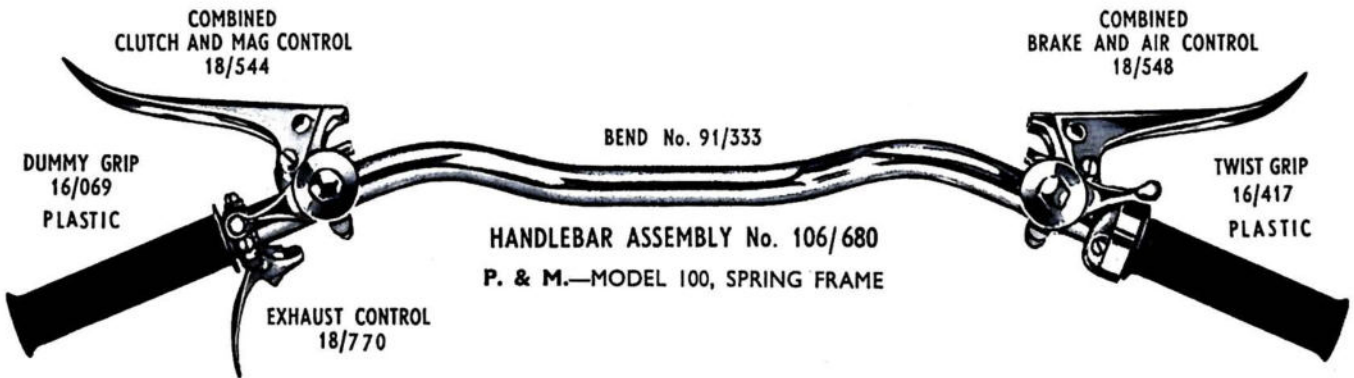
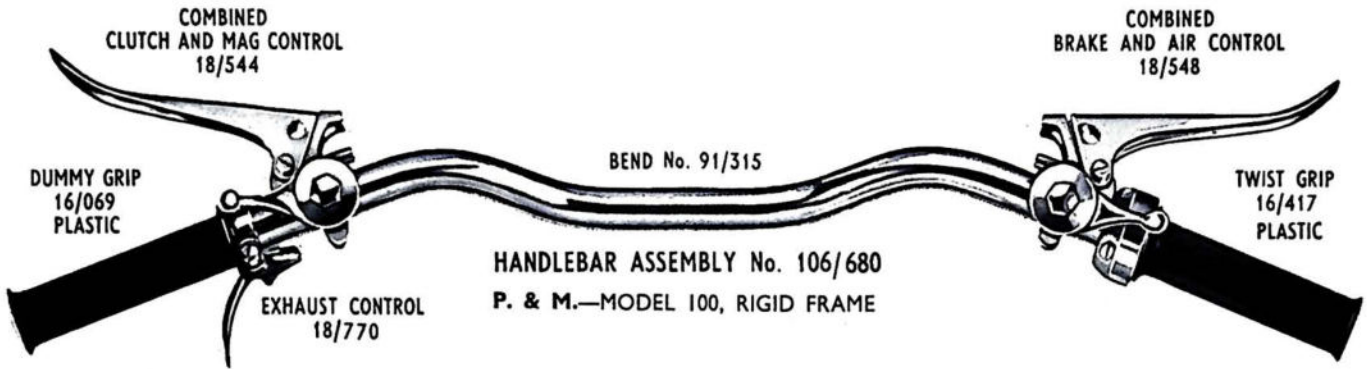

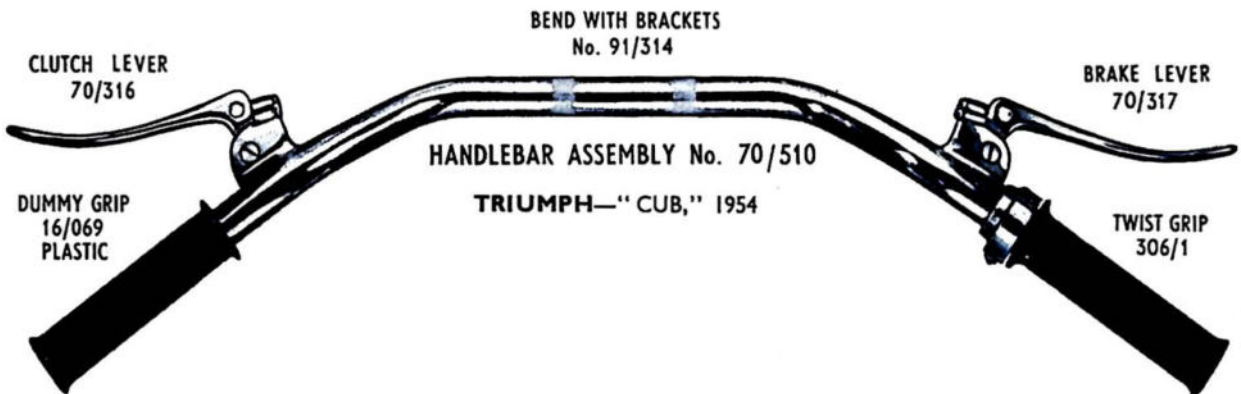
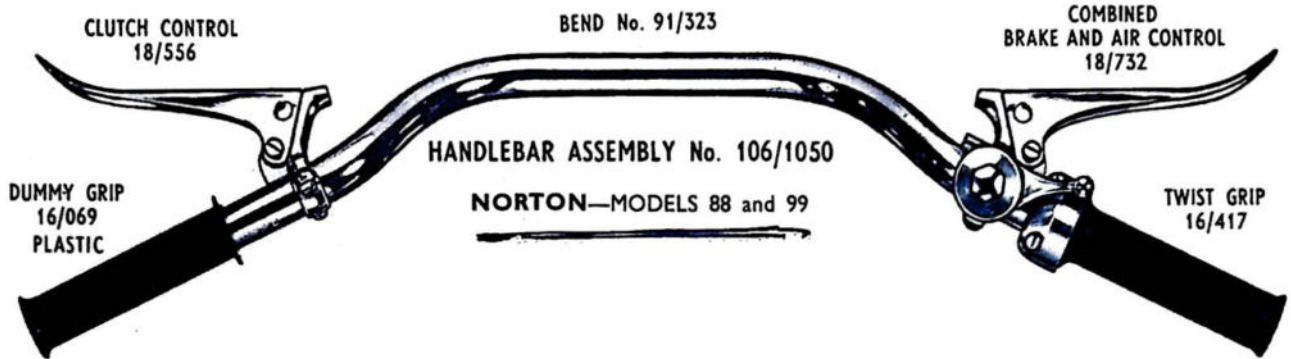

TWIST GRIPS 16/417 AND 306/1 REPLACED BY 366/1

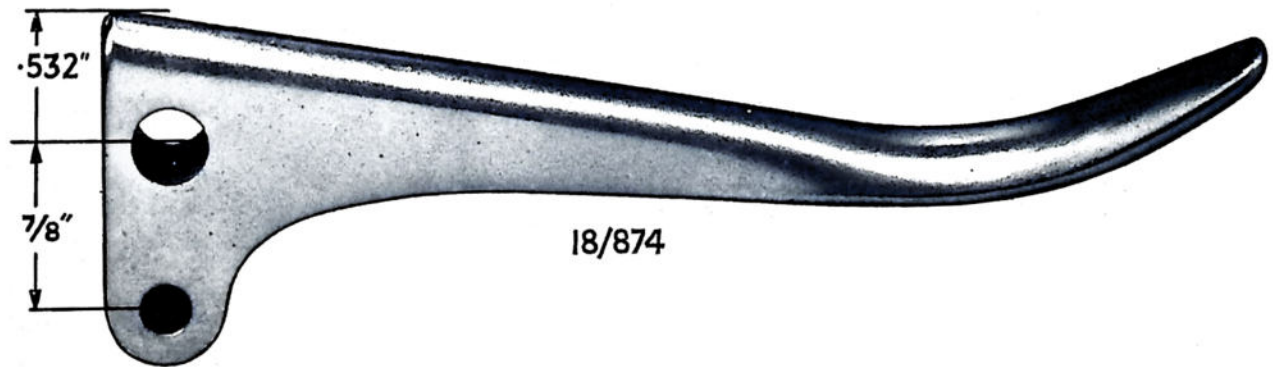
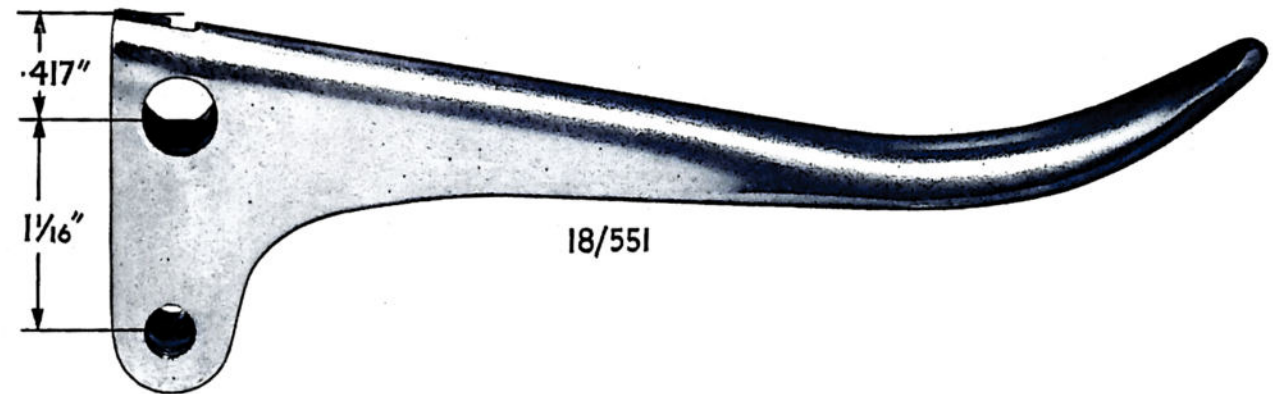
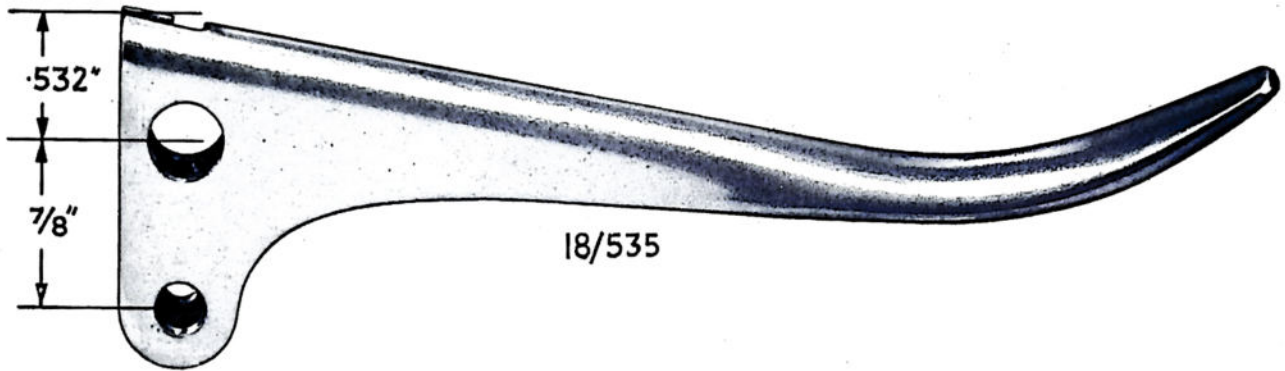
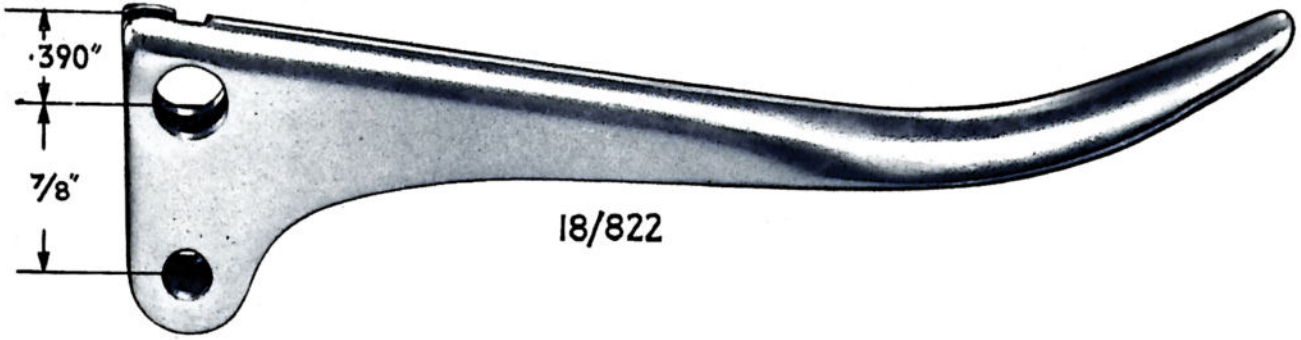

ACTUAL SIZE ILLUSTRATIONS

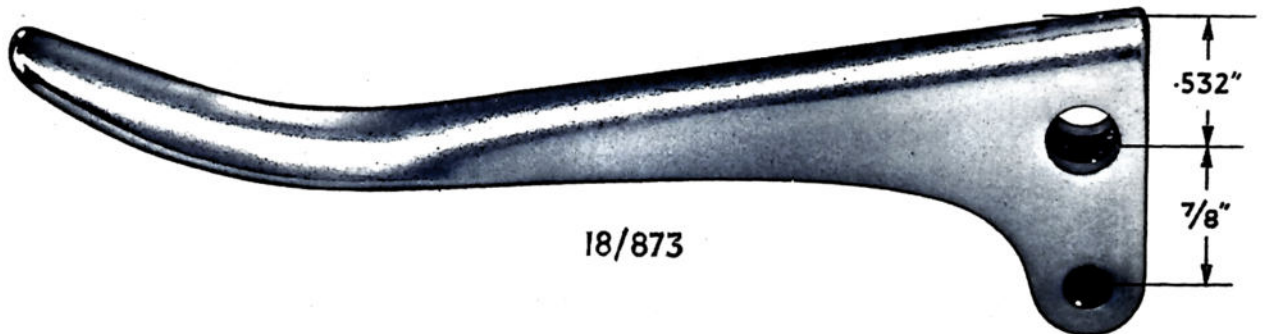
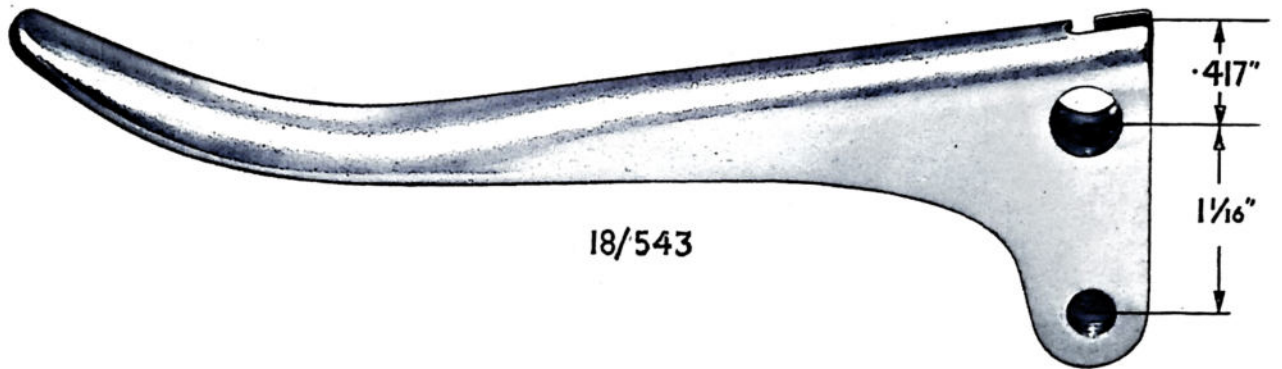
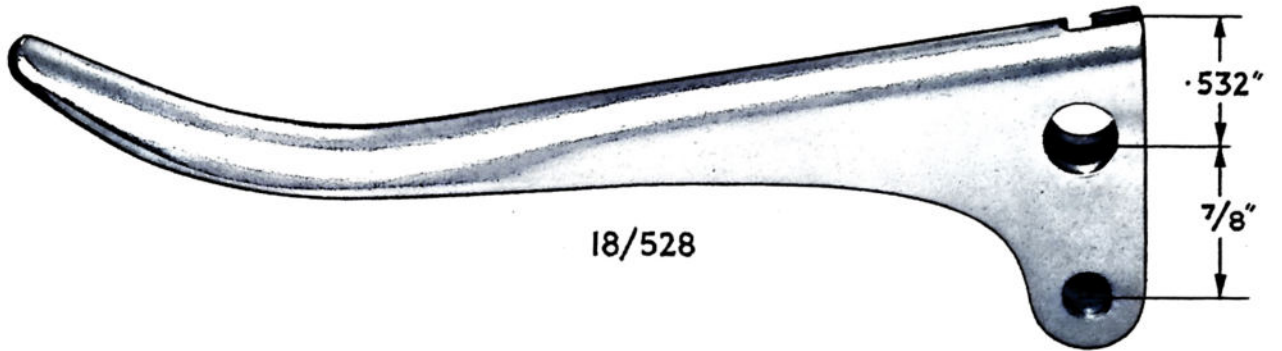
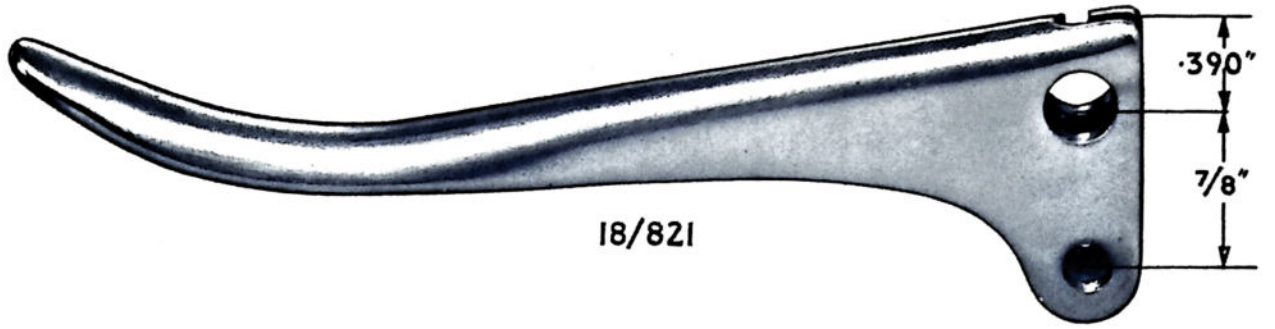

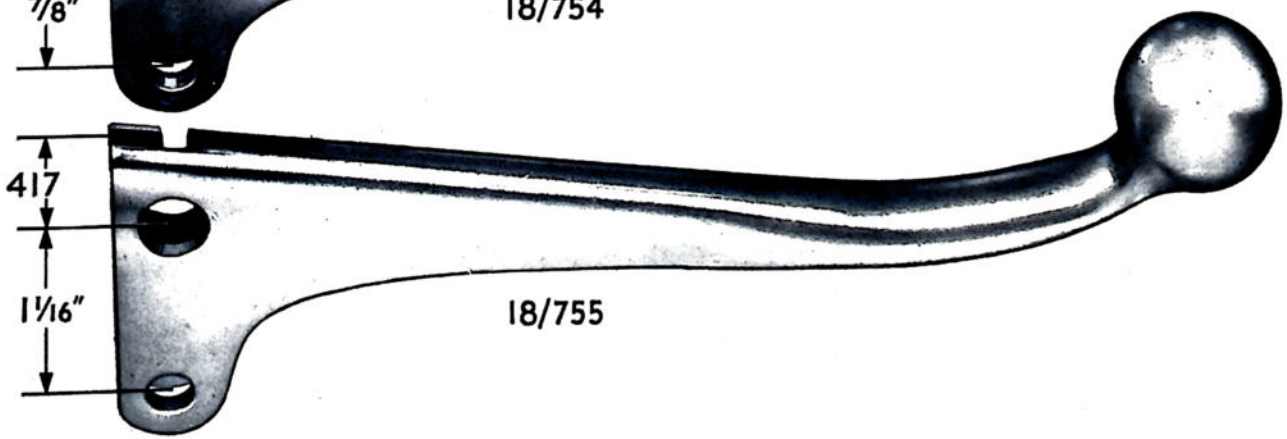
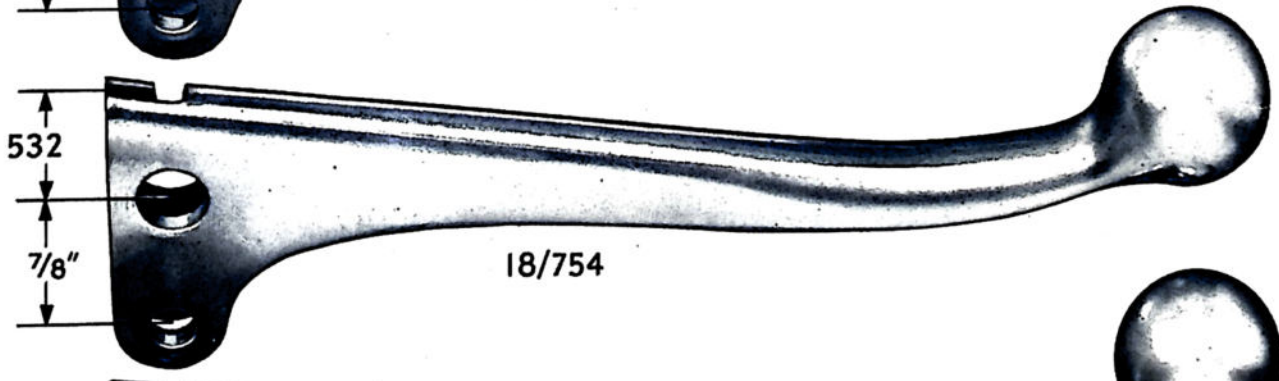
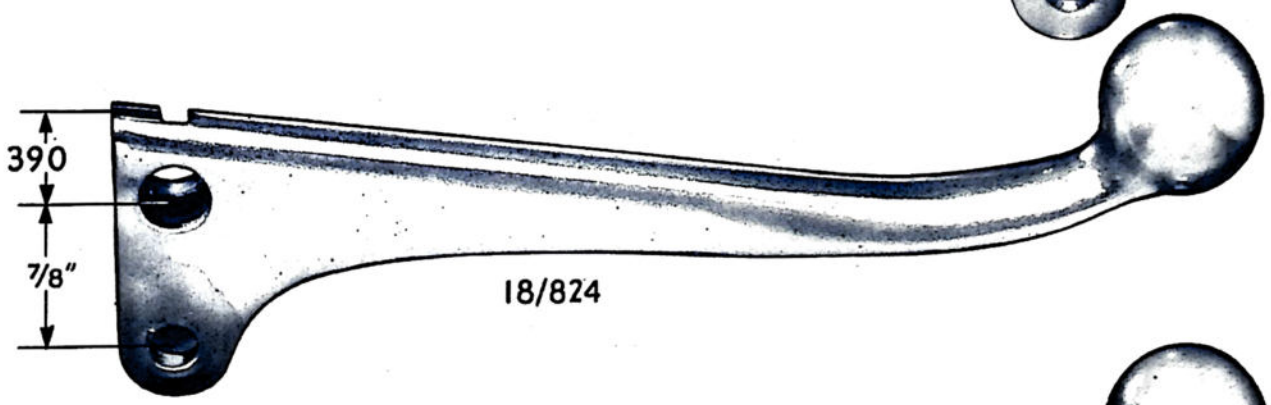
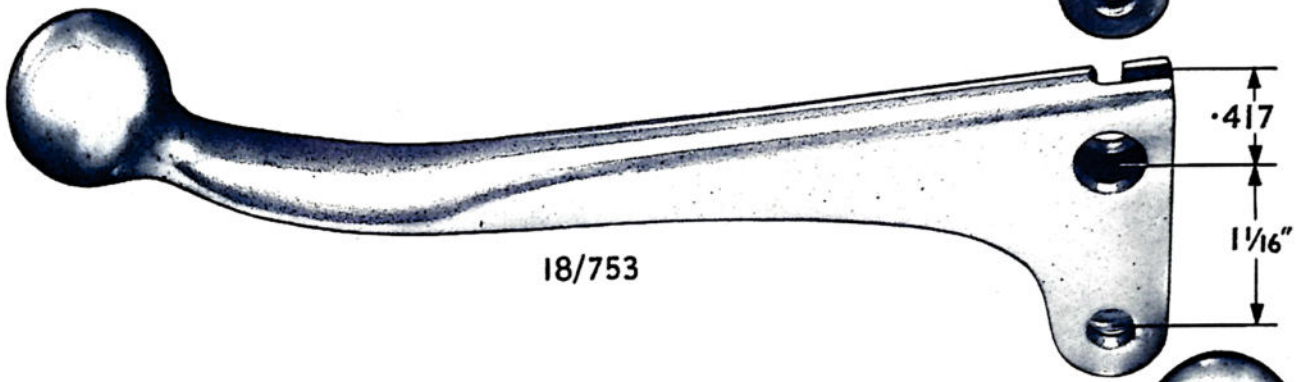
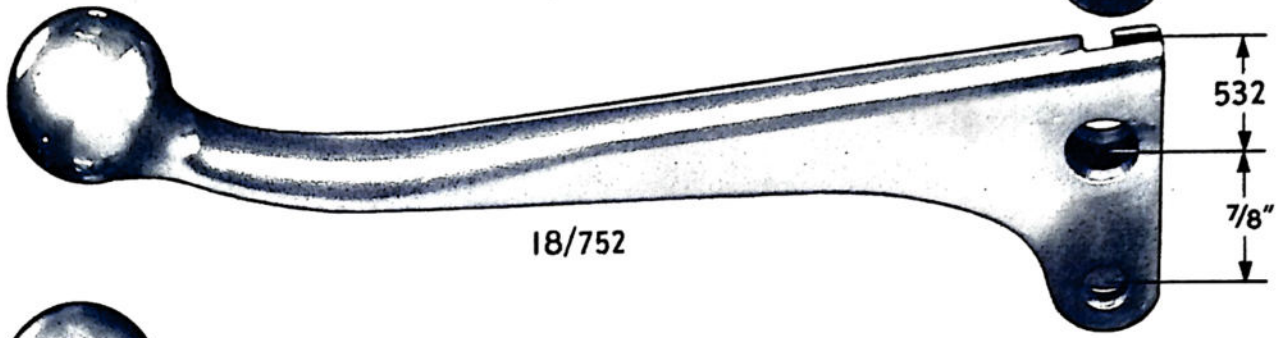
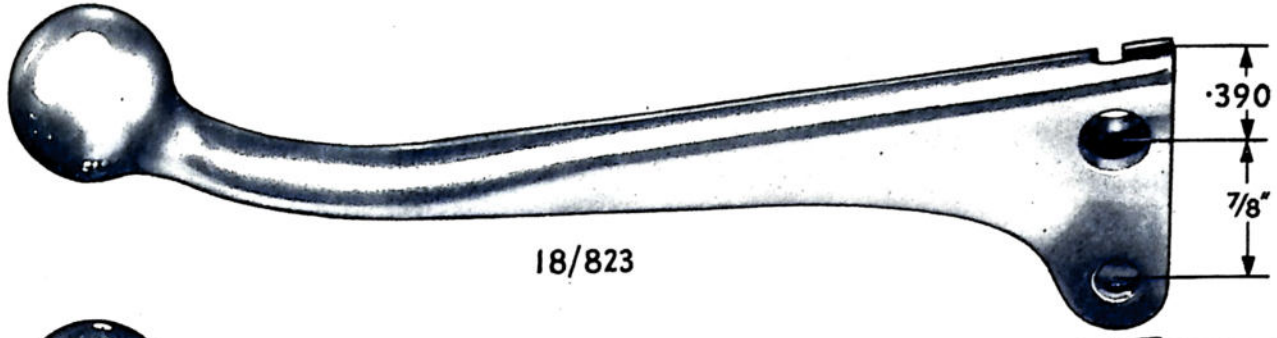

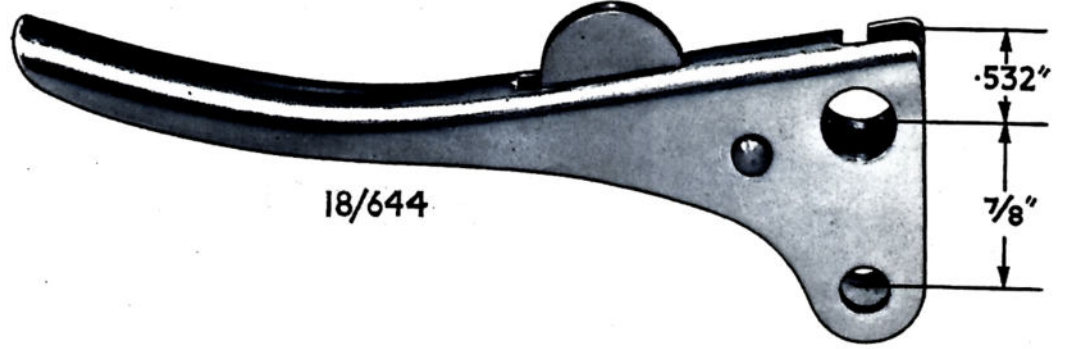
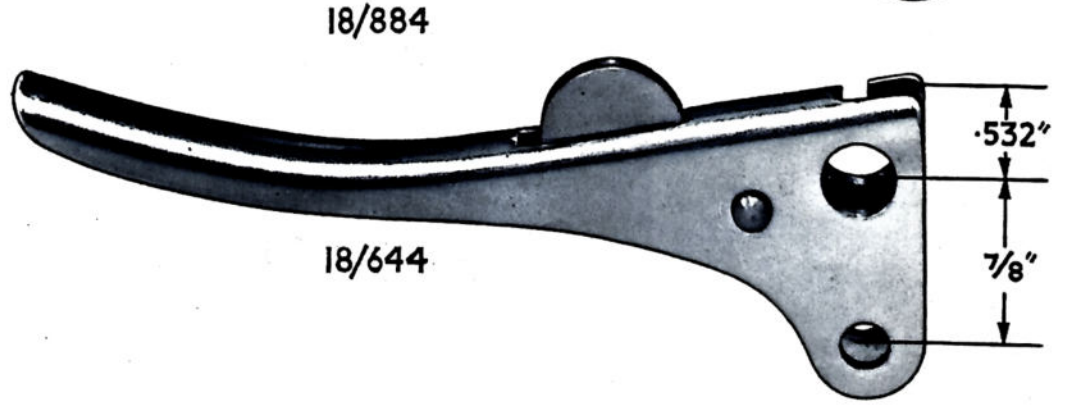
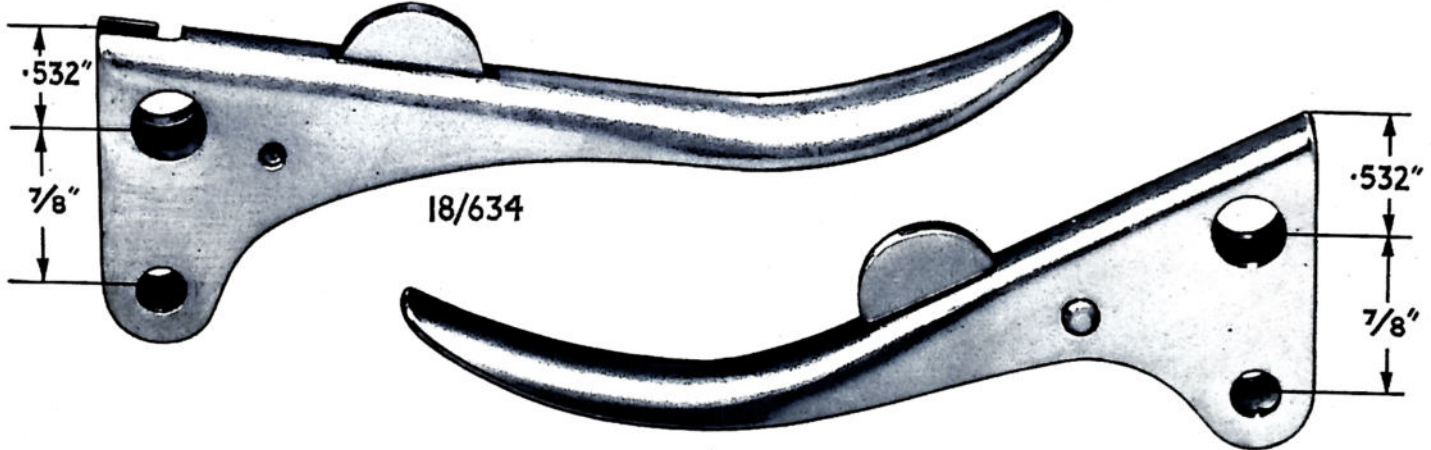
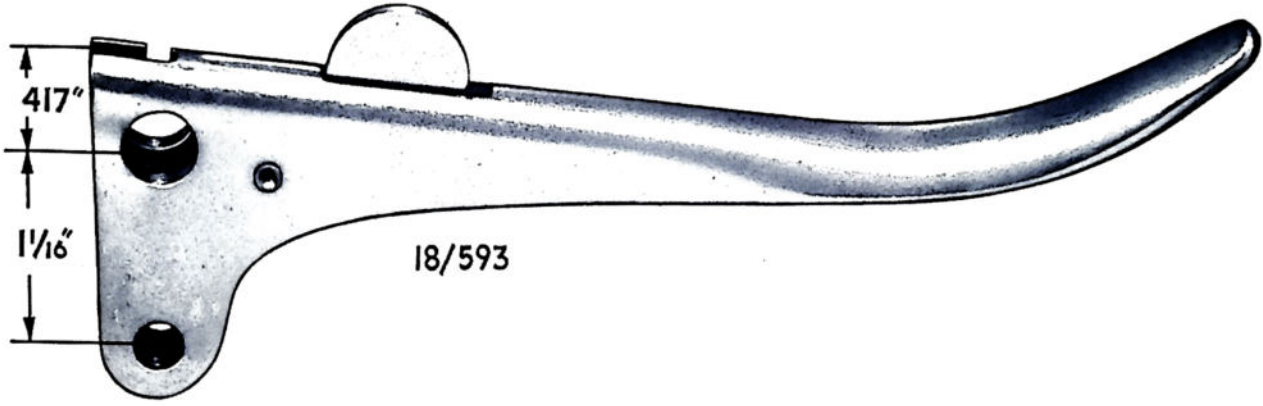
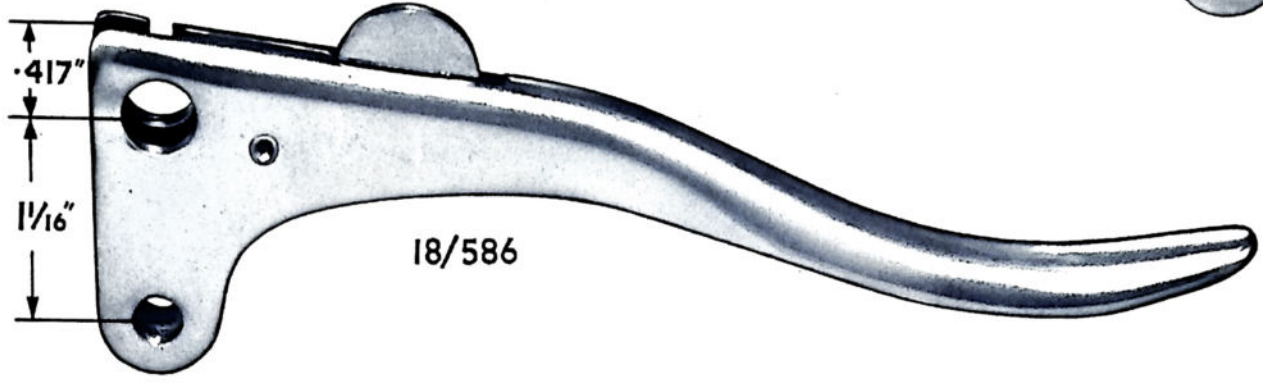
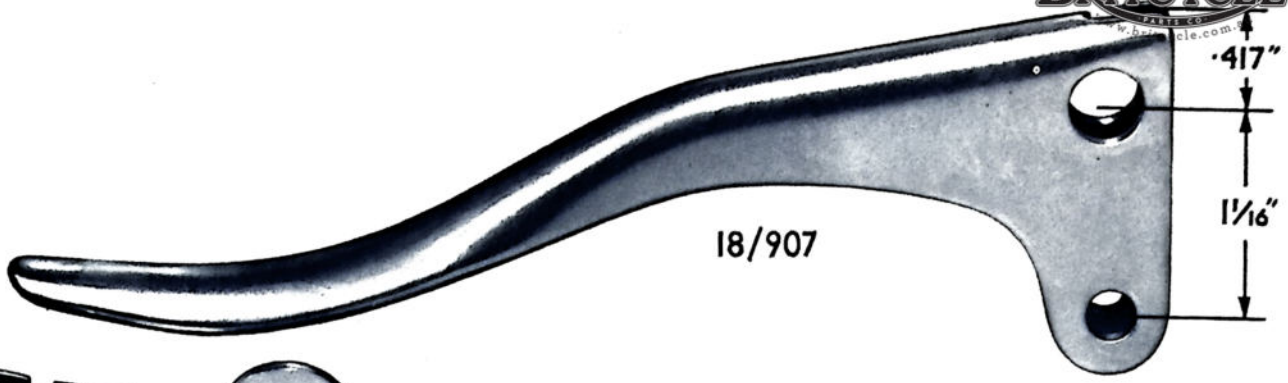

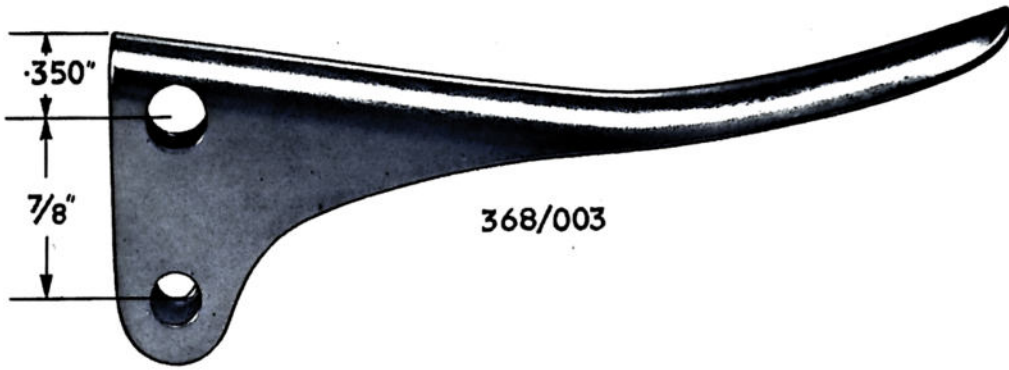

368/003

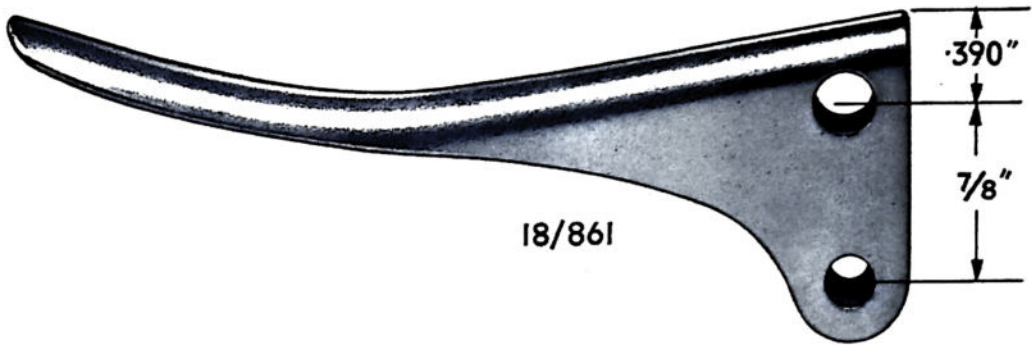

18/861

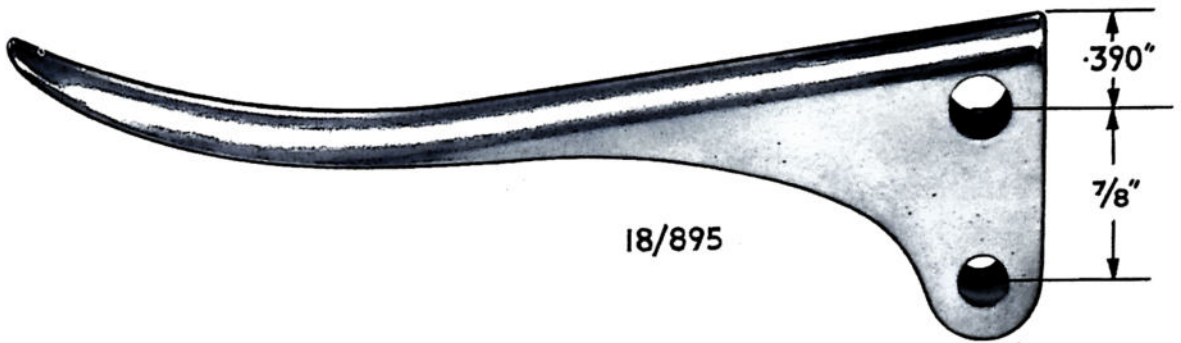

18/895



368/009

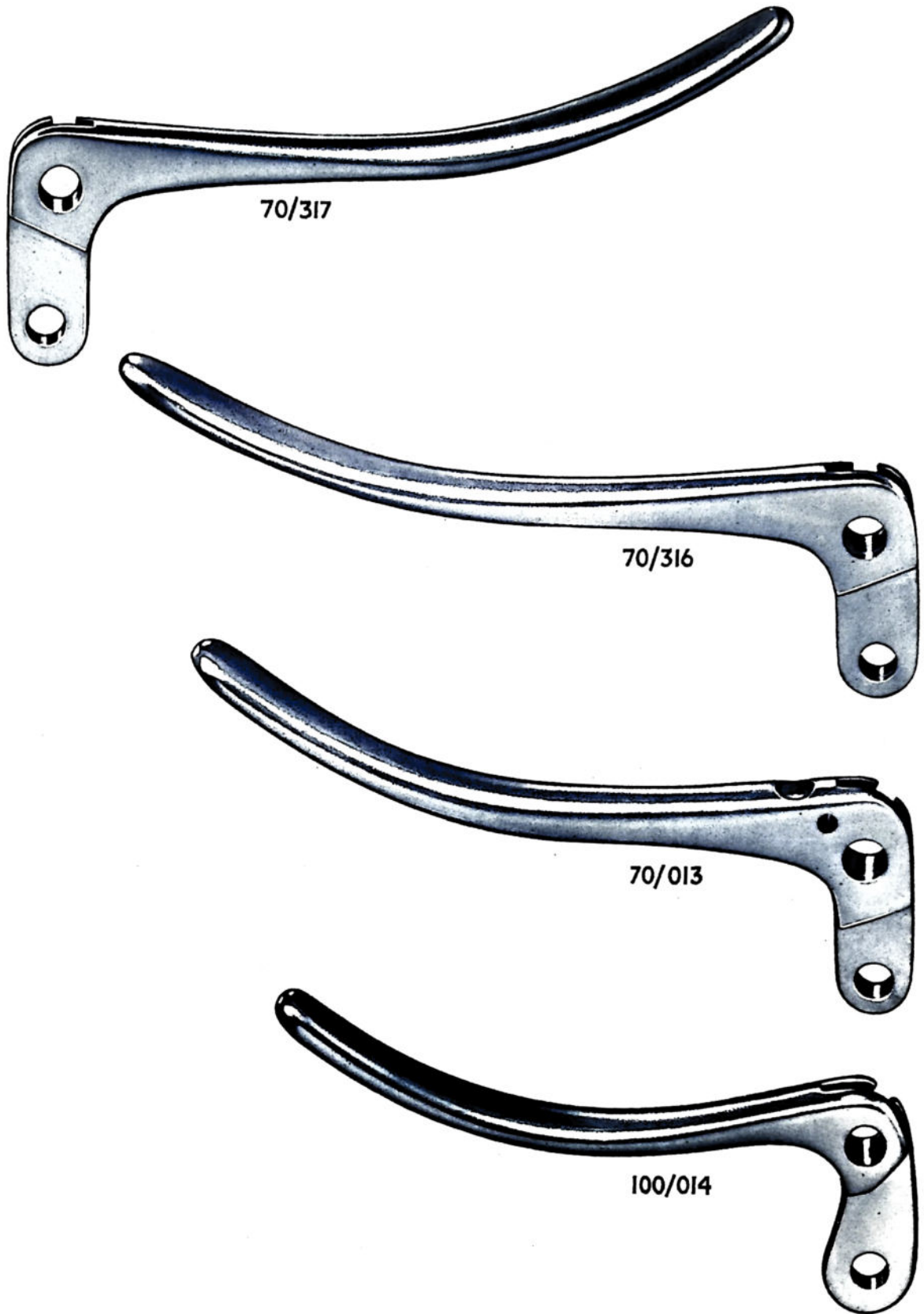

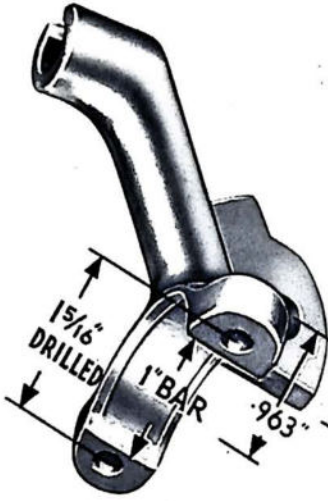

18/600

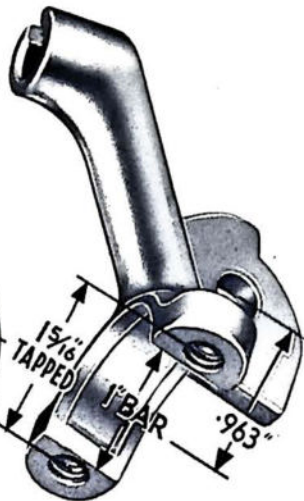

18/174

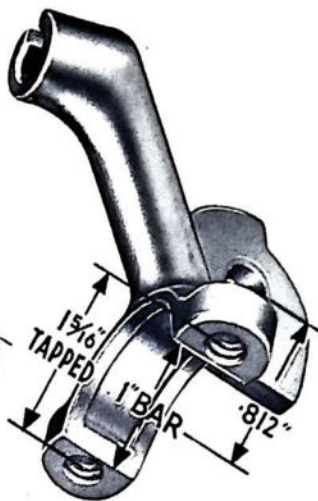

18/247

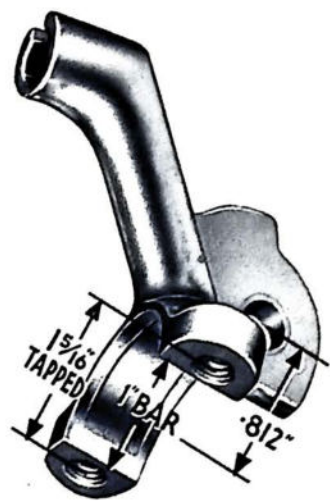

18/585

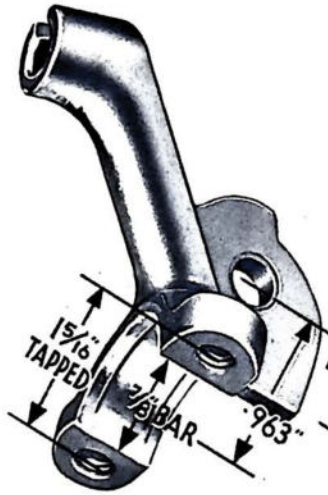

18/234

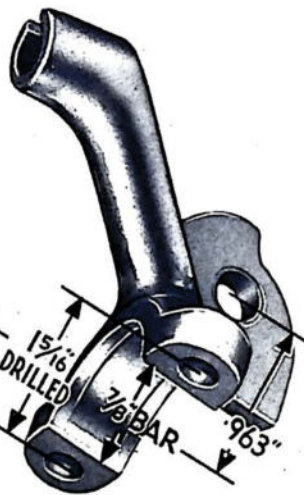

18/605

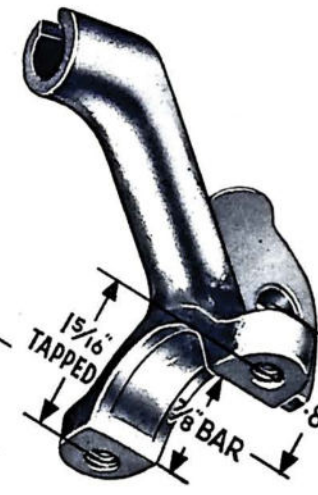

18/231

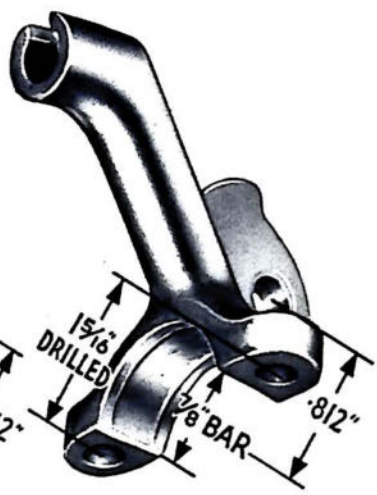

18/584



18/645



18/626



18/678

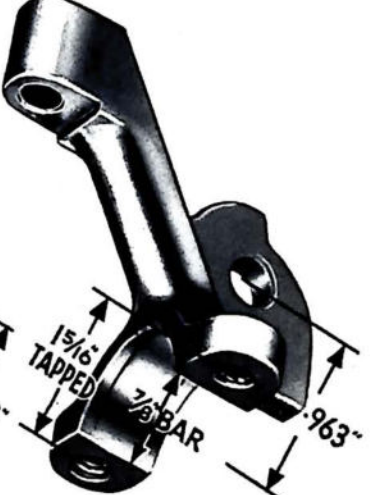

Cancelled

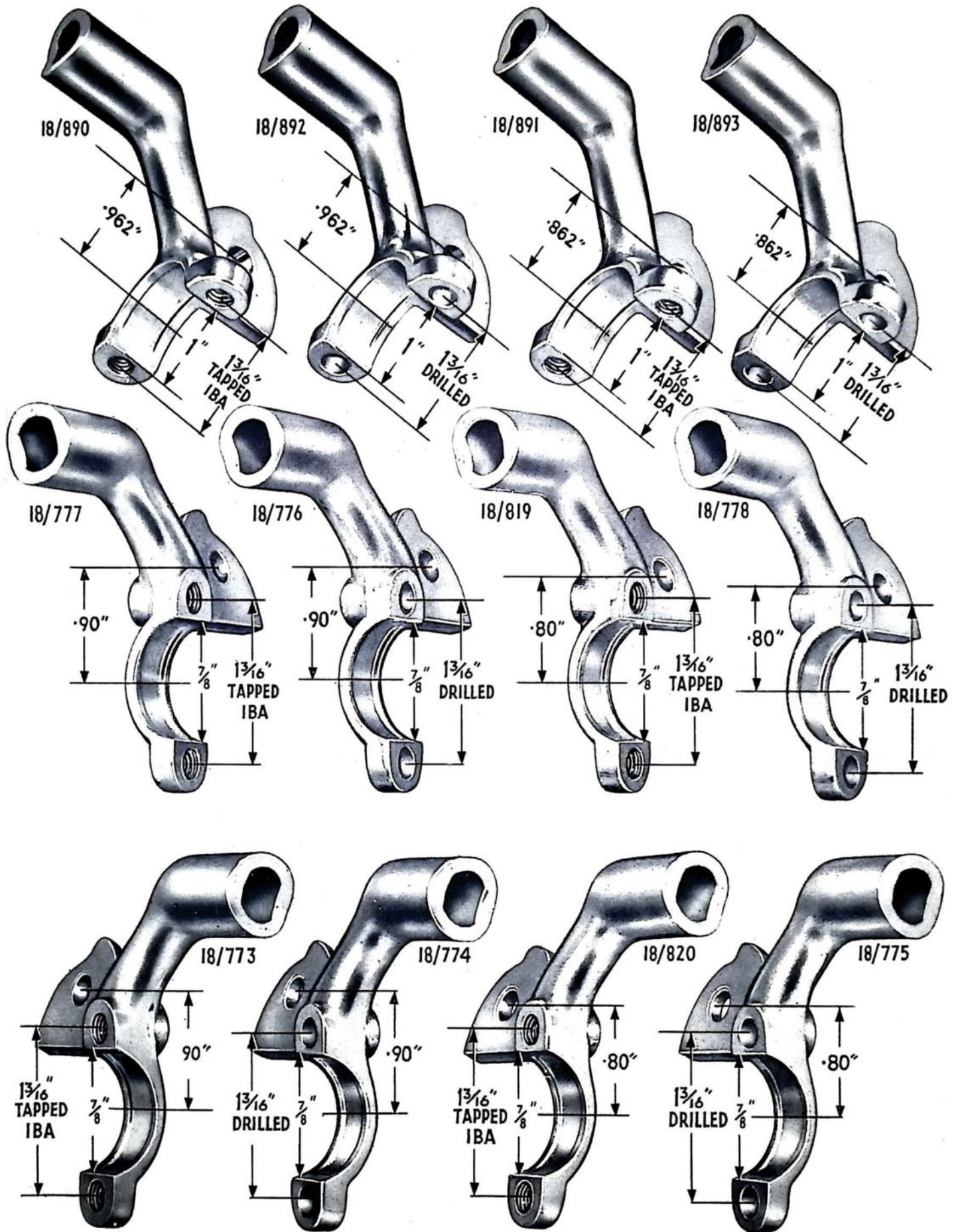

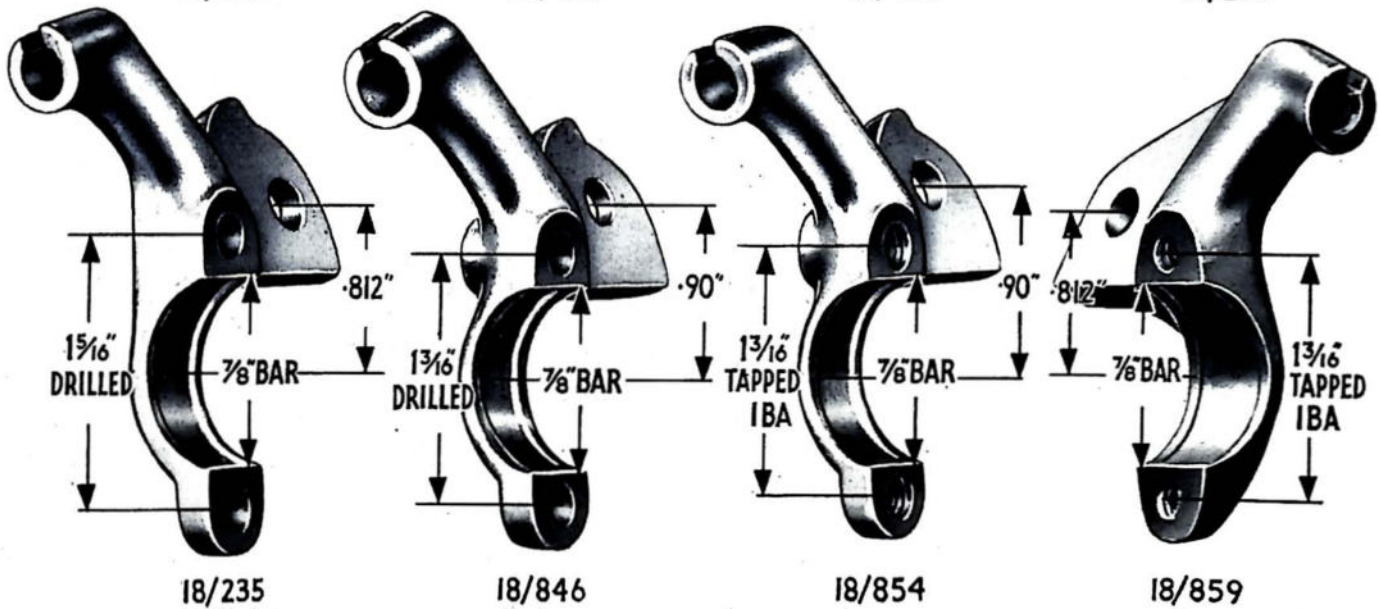
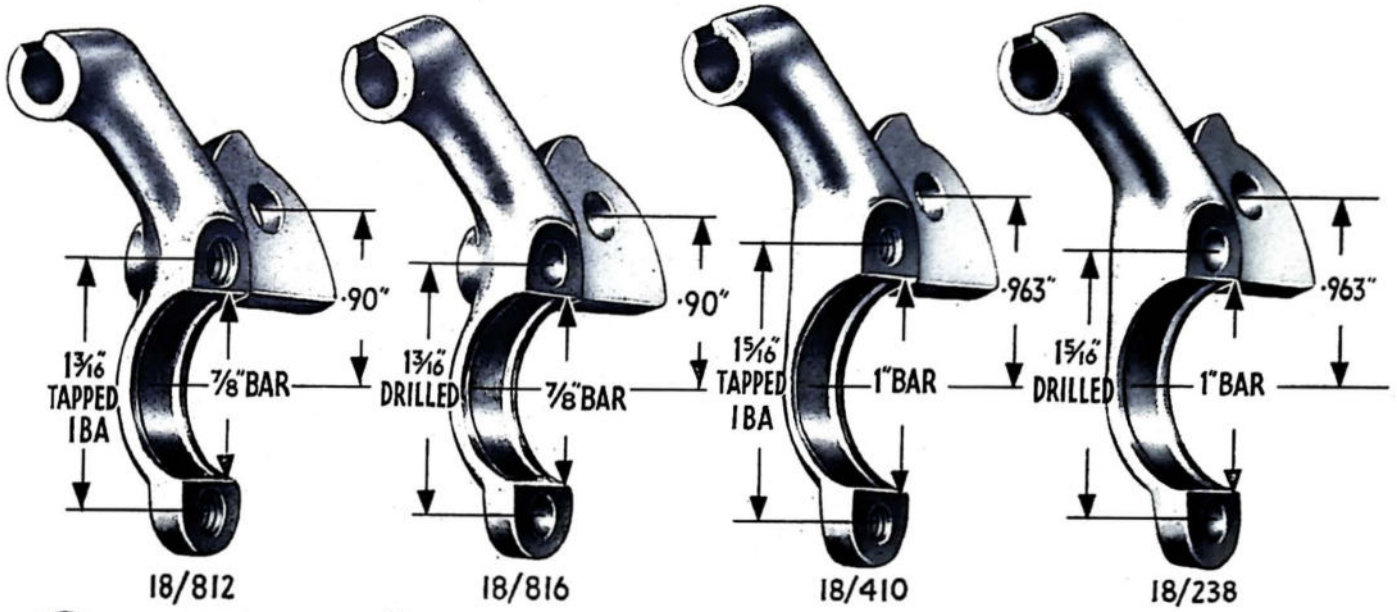
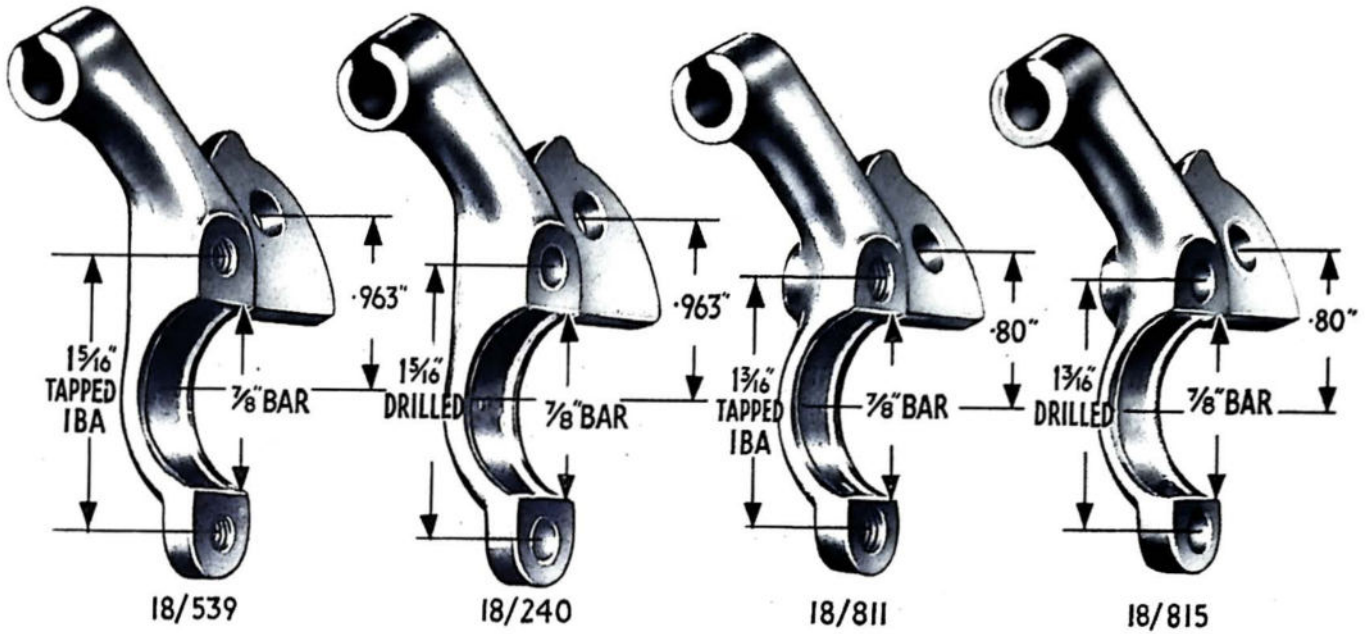

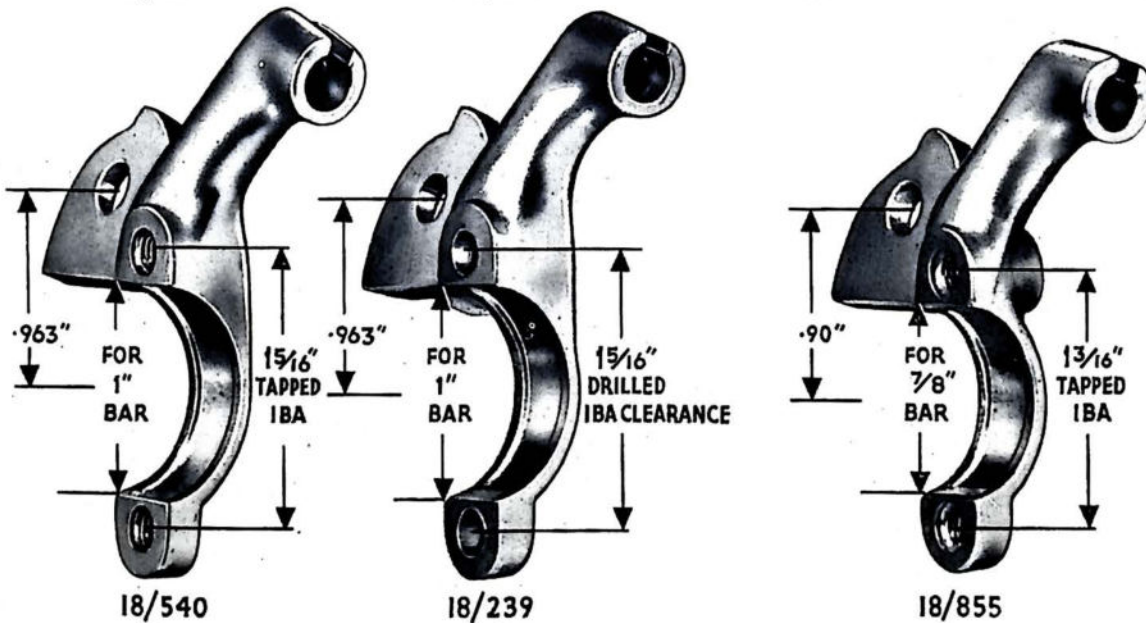
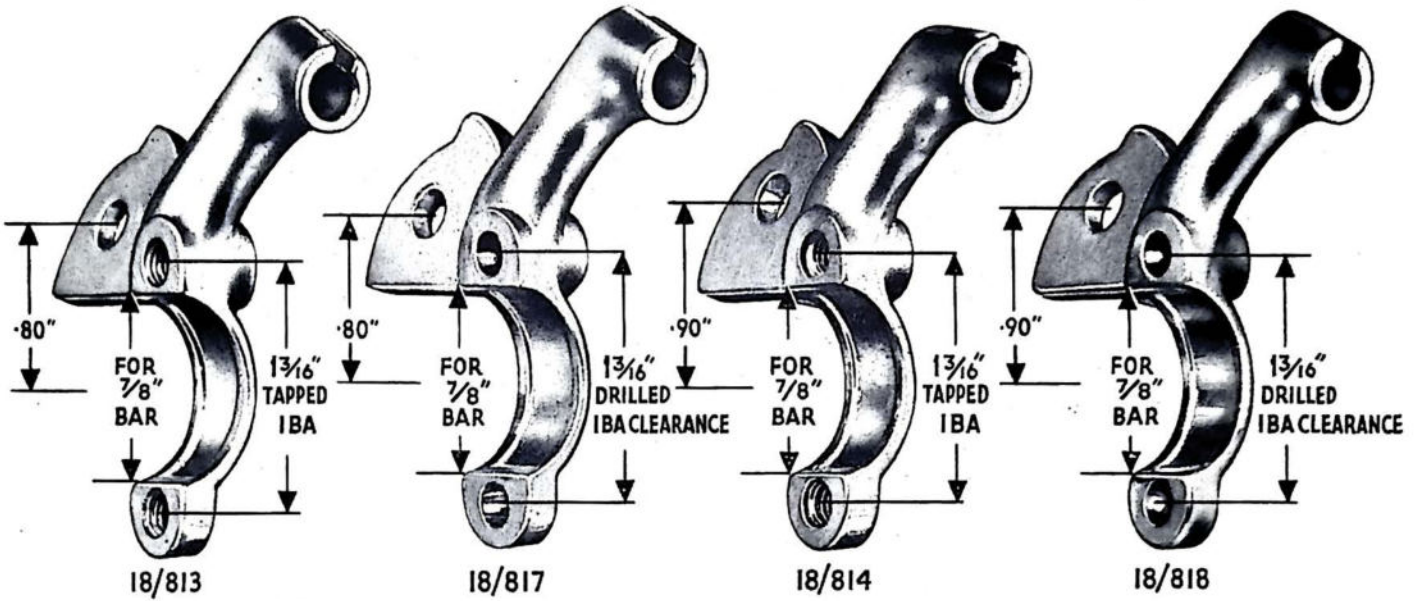
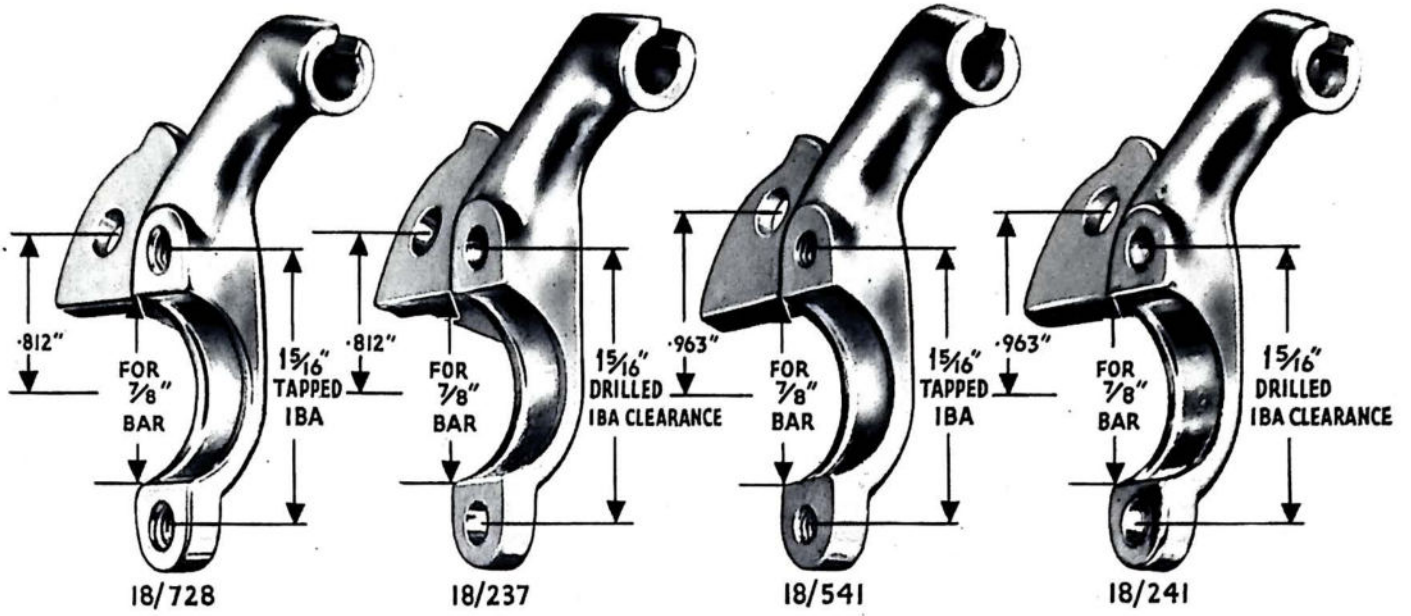



18/021



18/023



18/161



18/320



18/020



18/022



18/221



18/636



18/162



18/059



18/771



12/044



12/040



18/060

11/014

CLAMP SCREW
& FULCRUM PIN



12/012



12/434



12/014

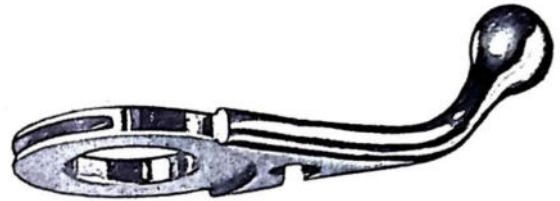

12/408



12/016



12/566



12/523

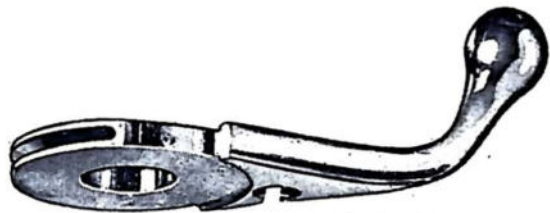

12/553

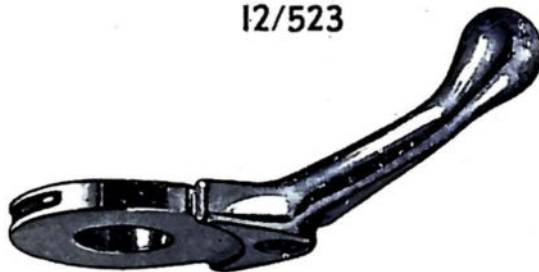

12/556



12/550



12/057

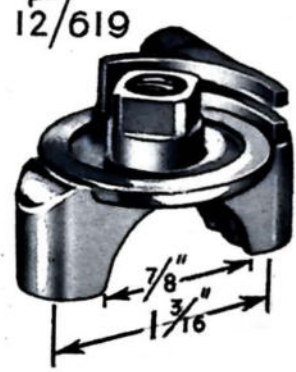
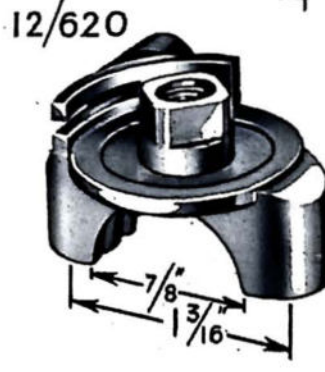
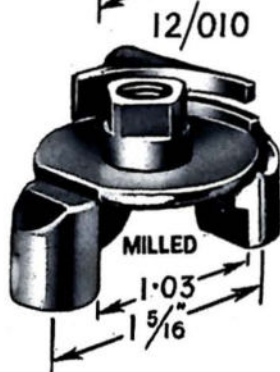
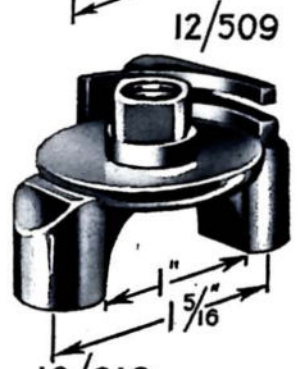
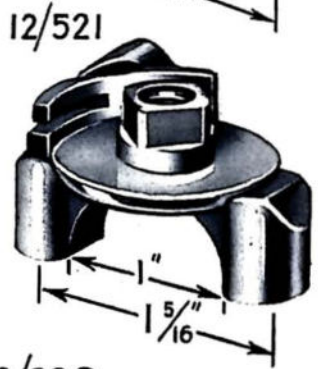
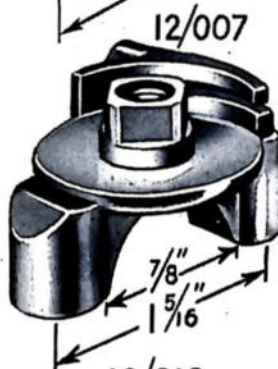
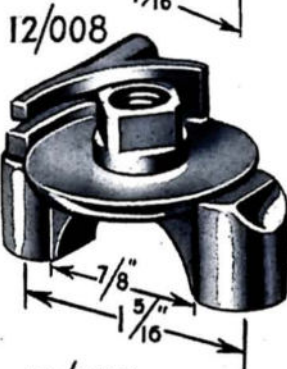
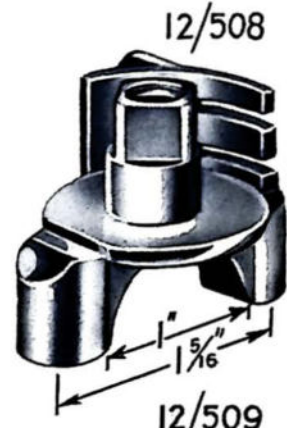
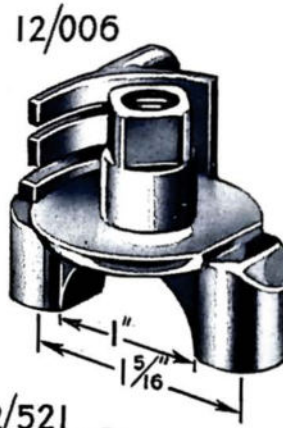
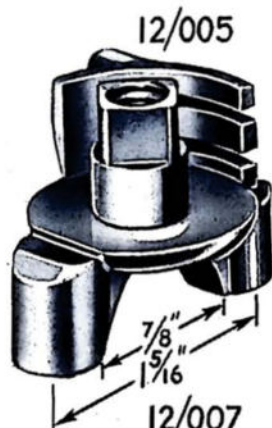
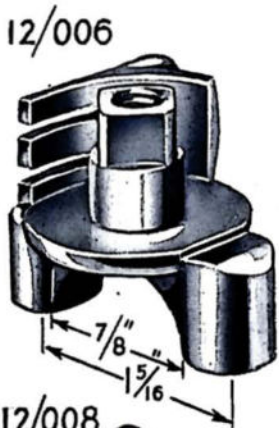
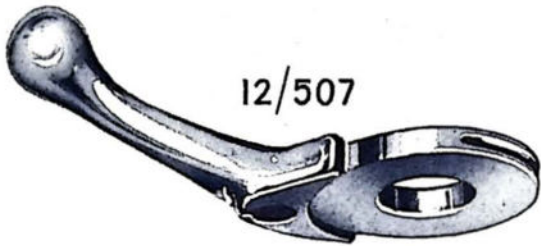
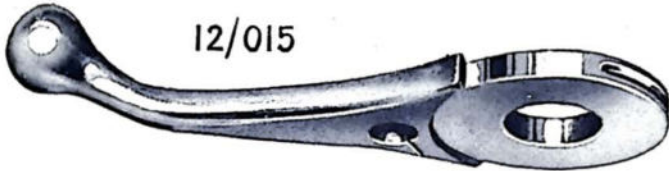
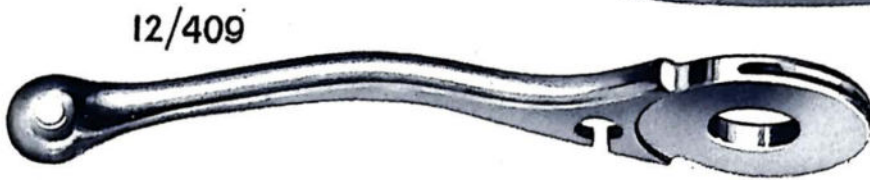



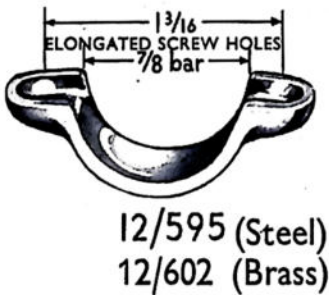
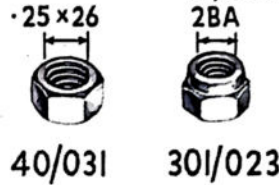
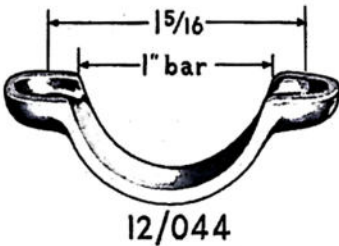
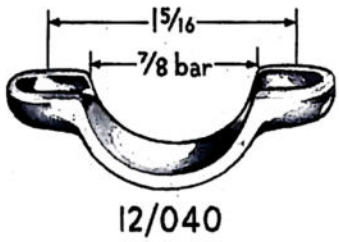
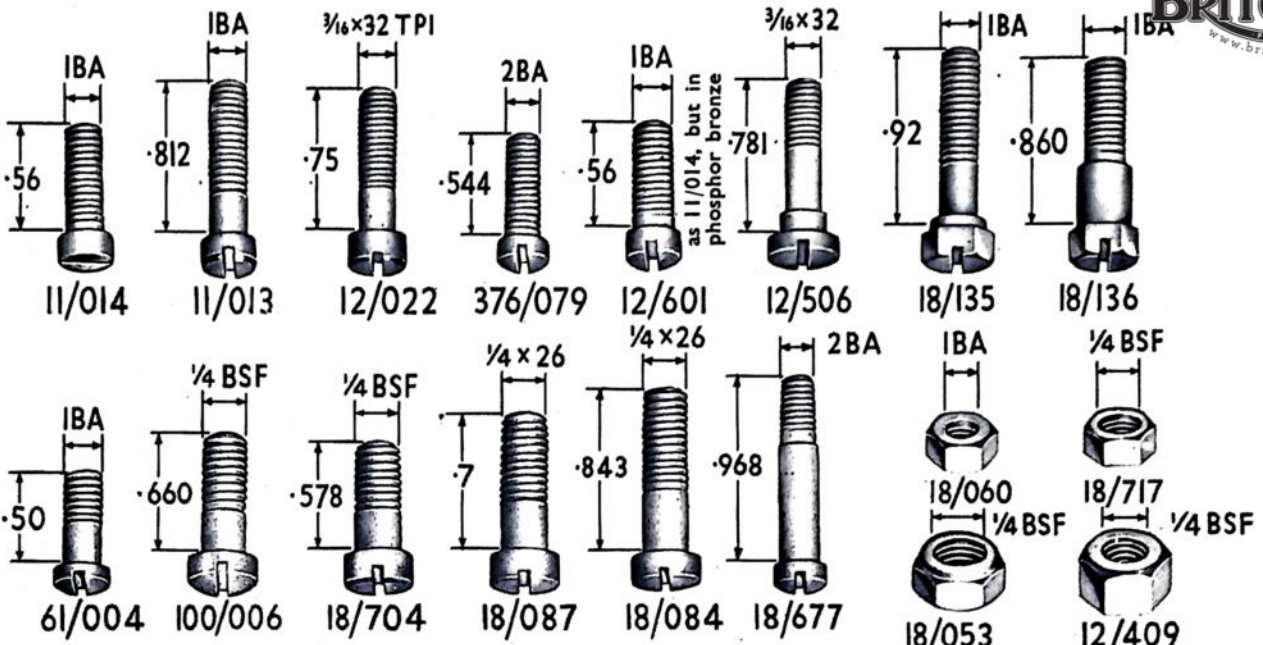

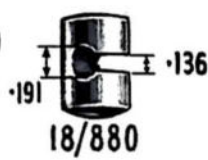
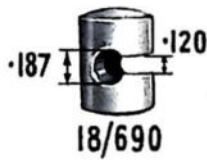
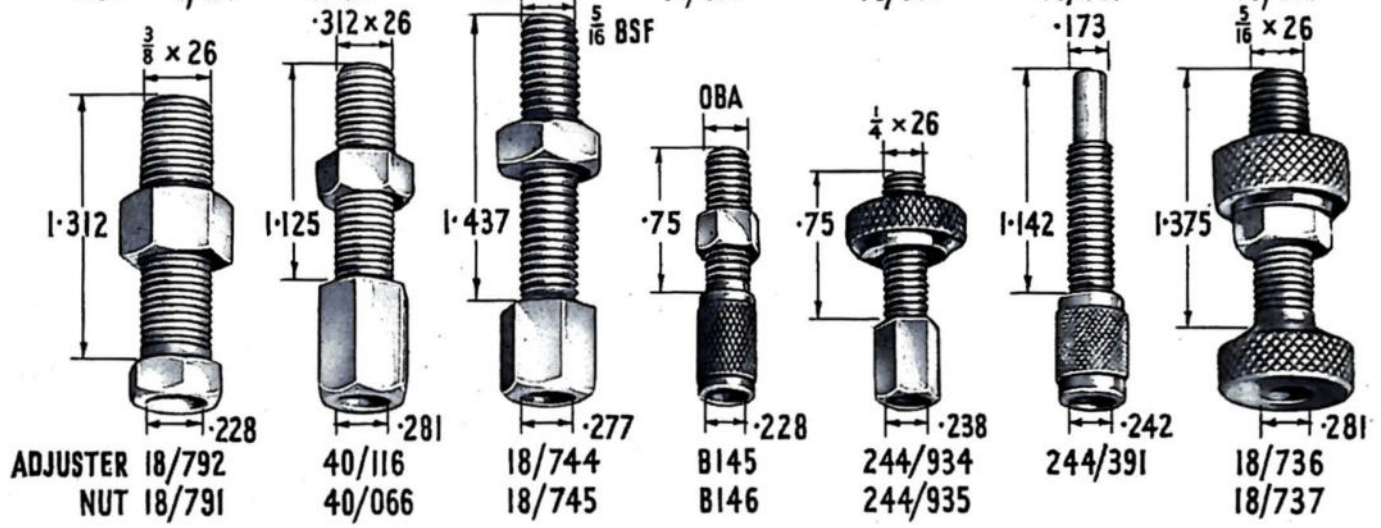
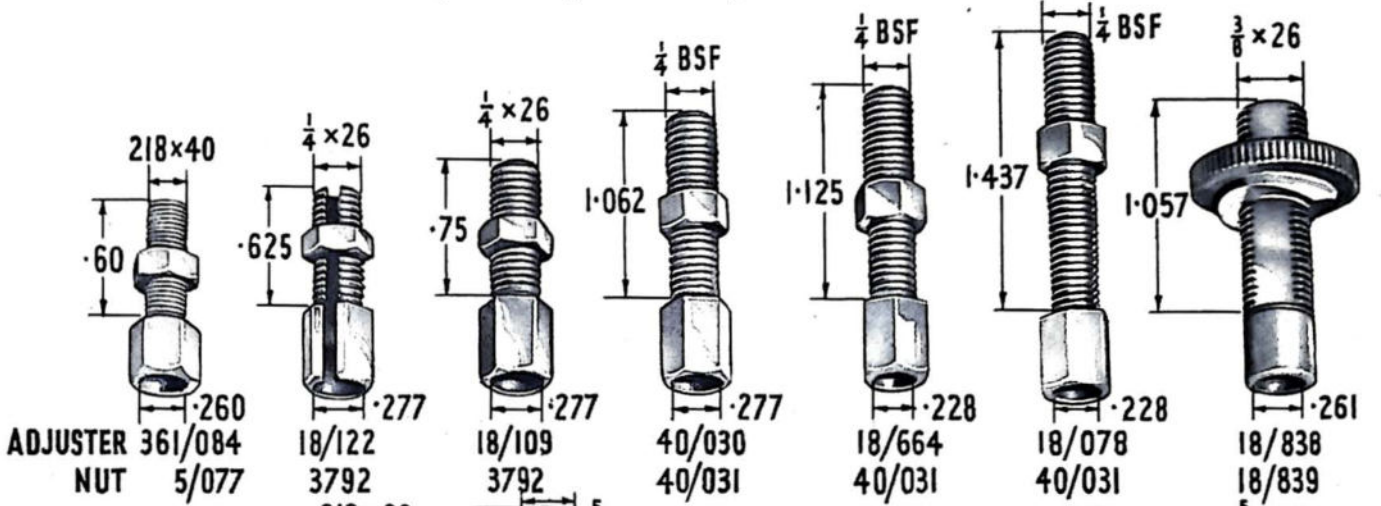
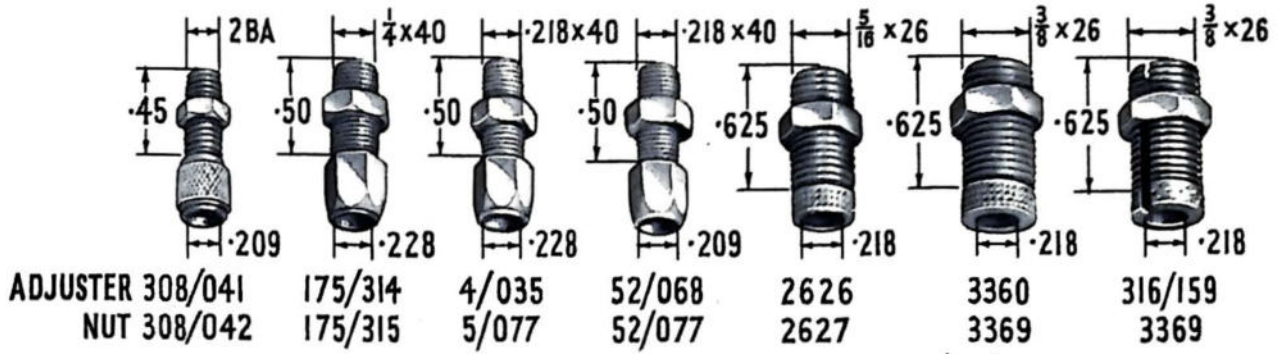

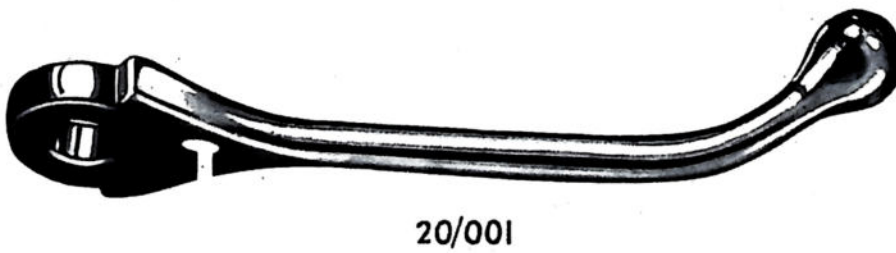
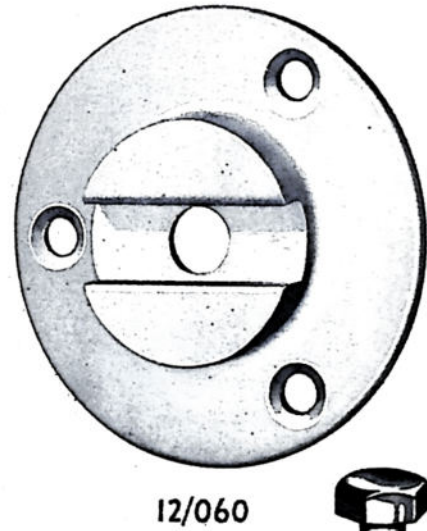
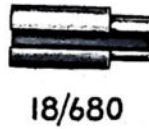
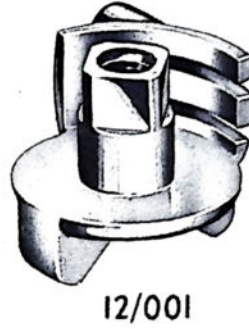
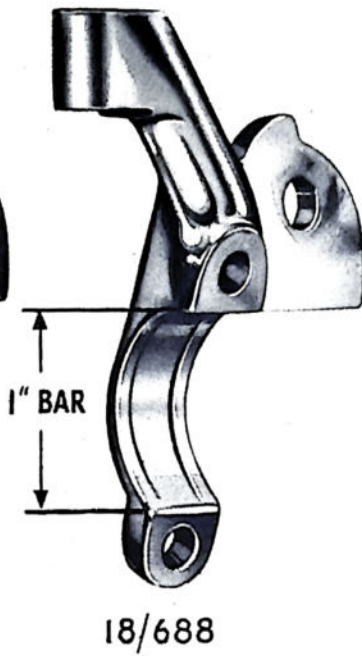
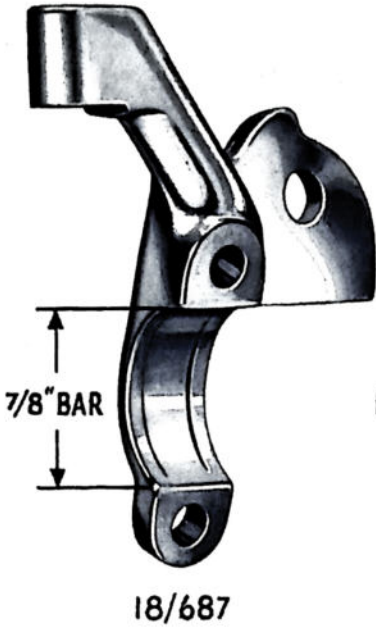



372/004



372/007

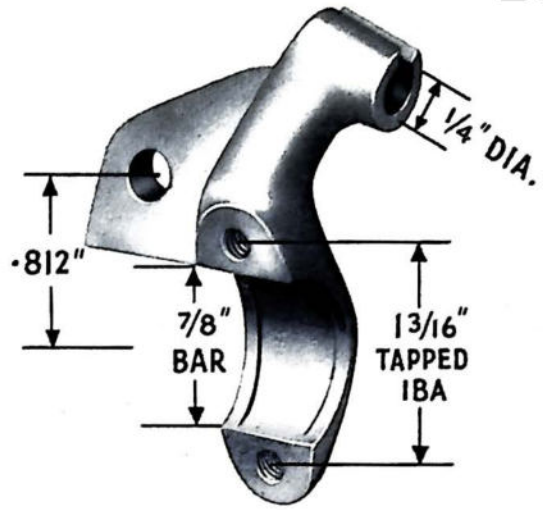

18/903



372/014

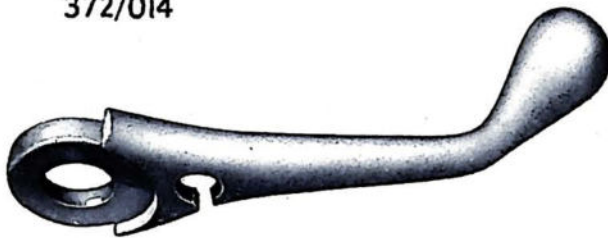

372/001

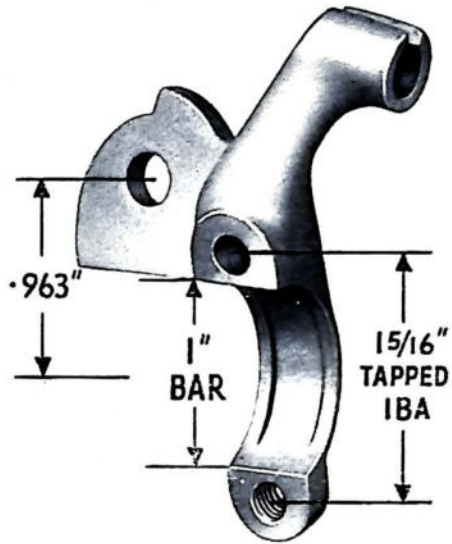

18/882



372/003
(3/4" BAR)



372/002
(7/8" BAR)



372/005



372/006



12/021



244/1348



244/1349

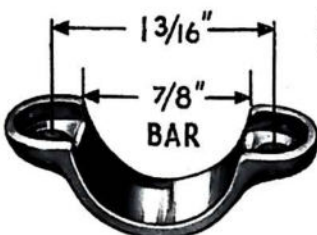

12/604

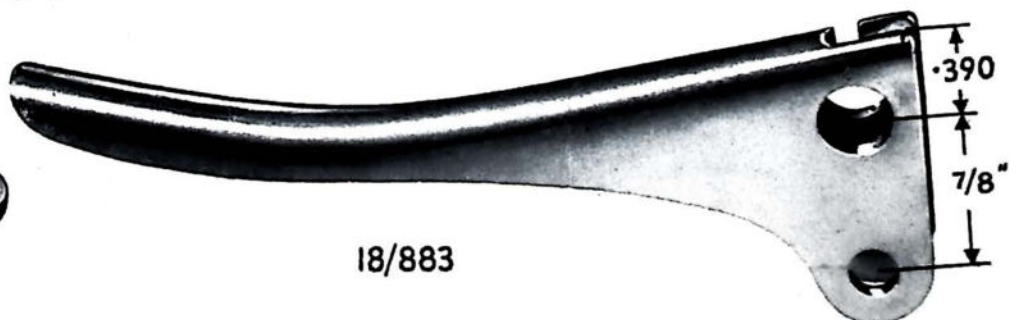

18/883