

AMAL

The Carburetter of Records & Successes

PARTS TO TUNE UP WITH

THROTTLE ADJUSTING SCREW (26). Set this screw to hold the throttle open sufficiently to keep the engine running when the twist grip is off. An "O" ring is fitted to the screw to hold this adjustment by friction.



MAIN JET (29). The main jet controls the petrol supply when the throttle is more than three-quarters open, but at smaller throttle openings although the supply of fuel goes through the main jet, the amount is diminished by the metering effect of the needle in the needle jet. Each jet is calibrated and numbered so that its exact discharge is known and two jets of the same number are alike. NEVER REAMER A JET OUT, GET ANOTHER OF THE RIGHT SIZE. The bigger the number the bigger the jet.

To remove the main jet, remove the float chamber, the exposed main jet can then be unscrewed from the jet holder (28).

NEEDLE AND NEEDLE JET (22 and 24). The needle being taper either allows more or less petrol to pass through the needle jet as the throttle is opened or closed throughout the range except when idling or nearly full throttle. The taper needle position in relation to the throttle valve can be set according to the mixture required by repositioning the jet needle clip in any of three positions thus raising or lowering it. Raising the needle enriches the mixture and lowering it weakens the mixture at throttle openings from one quarter to three-quarters open (see fig. 5, page 7). The throttle needles are marked with a single groove around the top diameter for use on the 600 series carburetter, the 900 series carburetter needles are identified by three grooves around the top of the needle, throttle needles identified by two grooves are used on certain models for both series 600 and 900 carburetters.

THROTTLE VALVE CUT-AWAY. The atmospheric side of the throttle is cut away to influence the depression on the main fuel supply and thus gives a means of tuning between the pilot and needle jet range of throttle opening. The amount of cut-away is recorded by a number marked on the throttle valve, viz., 622/3 means throttle valve type 622 with No. 3 cut-away; larger cut-aways, say 4 and 5, give weaker mixtures and 2 a richer mixture.

AIR VALVE (3) is used only for starting and running when cold, and for experimenting with, otherwise run with it wide open.

TICKLER (25), a small plunger spring loaded, fixed in the carburetter body. When pressed down on the float, the needle valve is allowed to open and so "flooding" is achieved. Flooding temporarily enriches the mixture until the level of the petrol subsides to normal.

ALCOHOL FUELS. When using alcohol fuels the following new components are necessary. A metallic banjo preferably double feed if not already fitted, banjo bolt washer 13/163, needle jet 622/100, jet needle 622/099 or 928/099 according to type of carburetter, filter gauze 376/093B and banjo washer 14/175. The main jet must be increased for straight alcohol by approximately 150%. The final setting must be a question of trial and error according to the nature of fuel used.

When using alcohol fuels it is advisable to err on the rich side to avoid engine overheating.

HOW TO TUNE UP

PHASES OF AMAL NEEDLE JET CARBURETTER THROTTLE OPENINGS

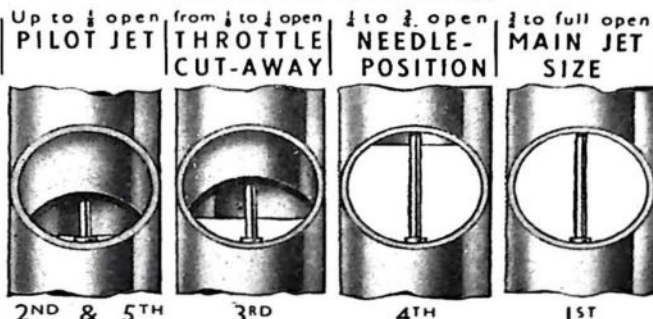

SEQUENCE OF TUNING

FIG. 5.

TUNE UP IN THE FOLLOWING ORDER.

NOTE. The carburetter is automatic throughout the throttle range—the air valve should always be wide open except when used for starting or until the engine has warmed up. We assume normal petrols are used.

READ REMARKS ON PAGES 6 AND 7 for each tuning device and get the motor going perfectly on a quiet road with a slight up gradient so that on test the engine is pulling.

1st. MAIN JET with throttle in position 1 (fig. 5). If at full throttle the engine runs "heavily" the main jet is too large. If at full throttle by slightly closing the throttle or air valve the engine seems to have better power, the main jet is too small. With a correct sized main jet the engine at full throttle should run evenly and regularly with maximum power. If testing for speed work ensure that the main jet size is sufficient for the mixture to be rich enough to keep the engine cool, and to verify this examine the sparking plug after taking a fast run, declutching and stopping the engine quickly. If the plug body at its end has a cool appearance the mixture is correct: if sooty, the mixture is rich: if however there are signs of intense heat, the mixture is too weak and a larger main jet is necessary.

2nd. PILOT JET (fig. 5) with throttle in positions 2 and 5. With engine idling too fast with the twist grip shut off and the throttle shut down on to the throttle adjusting screw, and ignition set for best slow running: (1) Screw out throttle adjusting screw until the engine runs slower and begins to falter, then screw pilot air adjusting screw in or out to make engine run regularly and faster. (2) Now gently lower the throttle adjusting screw until the engine runs slower and just begins to falter, adjust the pilot air adjusting screw to get best slow running: if this 2nd adjustment make engine run too fast, go over the job again a third time. Both the throttle adjusting screw and pilot air screw have an "O" Ring fitted to hold the adjustment by friction.

3rd. THROTTLE CUT-AWAY with throttle in position 3 (fig. 5). If, as you take off from the idling position, there is objectionable spitting from the carburetter, slightly enrich the pilot mixture by screwing in the air screw sufficiently, but if this is not effective, screw it back again, and fit a throttle with a smaller cut-away. If the engine jerks under load at this throttle position and there is no spitting, either the jet needle is much too high or a larger throttle cut-away is required to cure richness.

4th. NEEDLE with throttle in position 4 (fig. 5). The needle controls a wide range of throttle opening and also the acceleration. Try the needle in the lower position, viz., with the clip in the groove at the top: if acceleration is poor and with air valve partially closed the results are better, raise the needle by two grooves: if very much better try lowering needle by one groove and leave it where it is best. If mixture is still too rich with clip in groove No. 1 nearest the top—the needle jet probably wants replacement because of wear. If the needle itself has had several years' use replace it also.

5th. FINALLY go over the idling again for final touches.

TUNING TWIN ENGINES WITH TWIN CARBURETTERS

where each cylinder has its own Carburetter.

First of all, slacken the Throttle stop screws and put the Twist Grip into the shut off position to allow the Throttles to shut off: there should be a slight backlash in the cables which backlash can be obtained, if necessary, by screwing in the cable adjusting screws on the top of the Carburetter after releasing lock nuts. Then, with the Handlebars in the normal position, and with the Throttles closed, adjust the cable adjusting screws so that on the slightest opening of the Twist Grip, both Throttles begin to open simultaneously, then reset lock nuts.

To set the Carburetters, follow the procedure as given on page 7, and bear in mind these "Hints," which may be useful:—Main Jet sizes are of course selected by checking the effect of the Mixture on the Sparking Plugs after taking a run at full throttle over a straight piece of road: the smallest pair of jets that give the best maximum speed are usually correct provided that the Plugs do not show any signs of excessive heat. It might be that for really critical tuning, one Carburetter might require a slightly different Jet size from the other.

For slow running, set the Twist Grip to make the Engine run slowly but just faster than a "tick-over": then gently screw in the Throttle stops to just hold the Throttles in that position, and return the Twist Grip into the shut position, leaving the Engine running on the Throttle Stops.

The next thing to do is to set each Carburetter according to paragraph 2, on page 7, to obtain the idling by screwing down the Throttle Stop Screws and adjusting the Pilot Air Screws accordingly.

Regarding the setting of the Pilot, a fairly satisfactory method is to detach one Sparking Plug lead, and set the Pilot Air Adjusting Screw on the other Cylinder as a single unit, and then reversing the process to the other Cylinder. It may be found that when both leads are connected to the Sparking Plugs, the Engine runs slightly quicker than desirable, in which case, a slight readjustment of the Throttle Stop Screws will put this right. It is essential that the speed of idling on both Cylinders is approximately the same, as this will either make or mar the smoothness of the get-away on the initial opening of the Throttle.

It is essential with Twin Carburetters that the Throttle Slides are a good fit in the bodies, and also that there is no suspicion of air leaks at either of the flange attachments to the Cylinder.

Regarding the lower end of the Throttle range, which is always the more difficult to set, one can only take excessive pains to make quite sure that the Control Cables are perfectly adjusted, without any excessive backlash or difference in the amount of backlash between one Carburetter and another; otherwise one Throttle slide will be out of phase with the other, and so resulting in lumpy running.

To check the opening of the Throttle simultaneously, shut the Twist Grip back so that the Throttles are resting on the Throttle Stop Screws in their final position of adjustment; then insert the fingers into the air intakes and press them on the Throttles and with the other hand, gently open by the Twist Grip, and feel that the Throttles lift off their stops at the same time.

SERVICE ARRANGEMENTS

There are many AMAL Service Stockists in Great Britain and also in other countries where Motor-cycling is popular: They have information about recommended settings for all standard machines and, you are strongly advised to purchase GENUINE AMAL SPARES through them, at our List prices. ALL GENUINE JETS are stamped with the name AMAL and with the Calibration Number.

GUARANTEE.

The Company take all possible reasonable care in the manufacture and the quality of their products. Purchasers are informed that, any part proved to be defective in manufacture or quality, and returned to the works within six months of its purchase new, will be replaced. The Company must respectfully point out however, that its responsibility and that of its agents, stockists and dealers, is limited to this Guarantee and that they cannot, under any circumstances, be held responsible for any loss or for any contingent or resulting liability arising through any defect. The conditions of sale and use also apply when the Company's products form part of the original equipment of machines purchased new. 50m/4/68. W. Printed in England.

SECTIONAL ILLUSTRATIONS

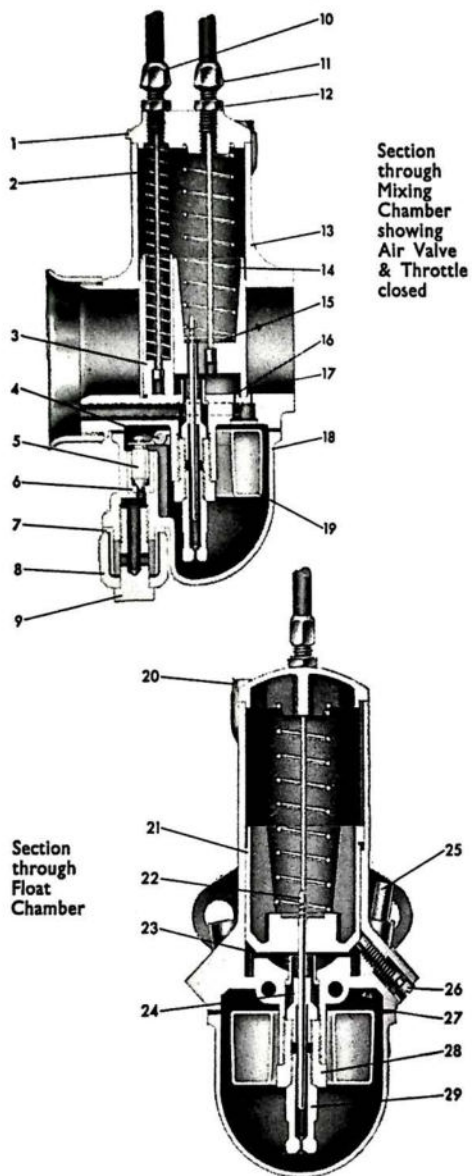

Section through Mixing Chamber showing Air Valve & Throttle closed

Section through Float Chamber

HOW THE CARBURETTER WORKS

The carburetter proportions and atomises the right amount of petrol with the air that is drawn in by the engine because of the correct proportions of jet sizes and the main choke bore. The float chamber maintains a constant level of fuel at the jets and cuts off the supply when the engine stops.

The throttle control from the handlebar controls the volume of mixture and therefore the power, and at all positions of the throttle the mixture is automatically correct. The opening of the throttle brings first into action the mixture supply from the pilot jet system for idling, then as it progressively opens, via the pilot by-pass the mixture is augmented from the main jet, the earlier stages of which action is controlled by the needle in the needle jet. The pilot jet system is supplied by the pilot jet (30) which is detachable on removal of the float chamber. On certain other models no pilot jet is fitted but a pilot bush is inserted in the continuation of the pilot air adjusting screw passage. The main jet does not spray directly into the mixing chamber, but discharges through the needle jet into the primary air chamber, and goes from there as a rich petrol-air mixture through the primary air choke into the main air choke.

The carburetters usually have a separately operated mixture control called an air valve, for use when starting from cold, and until the engine is warm; this control partially blocks the passage of air through the main choke.

This design of carburetter offers perfectly simple and effective tuning facilities.

- | | |
|-------------------------------|---------------------------------|
| 1—Mixing Chamber Top. | 18—Float Chamber Body. |
| 2—Air Valve Spring. | 19—Float. |
| 3—Air Valve. | 20—Mixing Chamber Top Screws. |
| 4—Float Spindle. | 21—Throttle Valve. |
| 5—Float Needle. | 22—Jet Needle. |
| 6—Needle Seating. | 23—Choke Tube. |
| 7—Filter Gauze. | 24—Needle Jet. |
| 8—Banjo. | 25—Tickler. |
| 9—Banjo Bolt. | 26—Throttle Adjusting Screw. |
| 10—Cable Adjuster (Air). | 27—Float Chamber Washer. |
| 11—Cable Adjuster (Throttle). | 28—Jet Holder. |
| 12—Cable Adjuster Locknuts. | 29—Main Jet. |
| 13—Carburetter Body. | 30—Pilot Jet. |
| 14—Throttle Valve Spring. | 31—Pilot Jet Feed Passages. |
| 15—Jet Needle Clip. | 32—Feed Passage from Pilot Jet. |
| 16—Pilot By-pass. | 33—Pilot Air Feed Passage. |
| 17—Pilot Outlet. | 34—Pilot Air Adjusting Screw. |

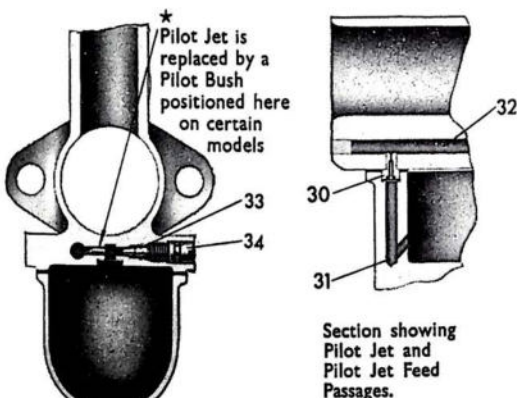

Section showing Pilot Jet and Pilot Jet Feed Passages.

HINTS AND TIPS

STARTING from cold. Turn on fuel supply, set ignition (if manually operated) for best slow running, depress tickler to flood float chamber, close air valve, open throttle slightly and start engine. When engine starts open air valve and close the throttle; if engine begins to falter, partially close the air valve until engine is warm, then set in fully open position.

STARTING, engine hot. Open throttle slightly and start engine. It should not normally be necessary to flood the float chamber or close the air valve when starting a warm engine.

STARTING, general. Experience will show when it is necessary to flood the carburetter or use the air valve and also the best setting of the throttle valve. If the carburetter has been over-flooded or strangled, which would result in a wet engine and over-rich starting mixture—fully open the throttle valve and air valve, give the engine several turns to clear the richness, then start again with the air valve fully open and the throttle valve slightly open.

STARTING, SINGLE LEVER CARBURETTERS. OPEN THE THROTTLE VERY SLIGHTLY FROM THE IDLING POSITION AND FLOOD THE CARBURETTER MORE OR LESS ACCORDING TO THE ENGINE BEING COLD OR HOT RESPECTIVELY.

CABLE CONTROLS. See that there is a minimum of backlash when the controls are set back and that any movement of the handlebar does not cause the throttle to open; this is done by the adjusters on top of the carburetter, after releasing the adjuster locknuts. See that the throttle valve shuts down freely, then reset locknuts.

PETROL FEED. A filter gauze is fitted at the inlet to the float chamber, to remove this gauze unscrew the banjo bolt (9) the banjo and filter gauze can then be removed. Before replacement ensure that the filter gauze is both clean and undamaged and check fuel supply by momentarily turning on fuel tap. Vertical loops in petrol pipes must be avoided to prevent air locks. Float chamber flooding may be due to a worn float needle but nearly all flooding and blockage of the filter gauze with new machines is due to impurities from the tank. Periodically clean out filter gauze and float chamber until the trouble ceases or alternatively the tank may be drained and swilled out, etc.

FIXING CARBURETTER AND AIR LEAKS. Erratic slow running is often caused by air leaks, so verify there are none at the point of attachment to the cylinder or inlet pipe. A sealing ring is fitted into the attachment flange of the carburetter. Also in old machines look out for air leaks caused by a worn throttle or worn inlet valve guide.

BANGING IN EXHAUST may be caused by too weak a pilot mixture when the throttle is closed or nearly closed—also it may be caused by too rich a pilot mixture and an air leak in the exhaust system; The reason in either case is that the mixture has not fired in the cylinder and has fired in the hot silencer. If the banging happens when the throttle is fairly wide open the trouble will be ignition—not carburation.

BAD PETROL CONSUMPTION of a new machine may be due to flooding, caused by impurities from the petrol tank lodging on the float needle seat and so prevent its valve from closing. Flooding may be caused by a worn float needle valve. Also bad petrol consumption will be apparent if the needle jet (24) has worn; it may be remedied or improved by lowering the needle in the throttle, but if it cannot be—then the only remedy is to get a new needle jet.

AIR FILTERS. These may affect the jet setting, so if one is fitted afterwards to the carburetter the main jet may have to be smaller. If a carburetter is set with an air filter and the engine is run without it, take care not to overheat the engine due to too weak a mixture; testing with the air valve (page 5), will indicate if a larger main jet and higher needle position are required.

EFFECT OF ALTITUDE ON CARBURETTER. Increased altitude tends to produce a rich mixture. The greater the altitude, the smaller the main jet required. Carburetters ex-works are set suitable for altitudes, up to 3,000 feet approximately. Carburetters used constantly at altitudes 3,000 to 6,000 feet should have a reduction in main jet size of 5 per cent, and thereafter for every 3,000 feet in excess of 6,000 feet altitude further reductions of 4 per cent, should be made.

RE-ASSEMBLING

When replacing the valve assembly see that the jet needle goes into the holes in the choke tube, needle jet and main jet and that both the throttle and air valve spring locate correctly in the mixing chamber top.

When refitting the float, engage the float needle recess in the horseshoe section of the float and fit in float chamber. Check that the needle jet (24) jet holder (28) and main jet (29) are fully tightened together before screwing assembly into the body.

HOW TO TRACE FAULTS

There are only two possible faults in carburation, either richness or weakness of mixture.

INDICATIONS OF :-

RICHNESS.

Black smoke in exhaust.
Petrol spraying out of carburetter.
Four strokes, eight-stroking.
Two strokes, four-stroking.
Heavy, lumpy running.
Sparkling plug sooty.

WEAKNESS.

Spitting back in carburetter.
Erratic slow running.
Overheating.
Acceleration poor.
Engine goes better if :-
Throttle is not wide open or
Air Valve is partially closed.

If richness or weakness is present, check if caused by :-

- | | |
|---|---|
| (1) Petrol feed. | Check that jets and passages are clear, that filter gauze in float chamber banjo connection is not choked with foreign matter, and that there is ample flow of fuel.
Check there is no flooding. |
| (2) Air leaks. | At the connection to the engine or due to leaky inlet valve stems. |
| (3) Defective or worn parts. | As a loose fitting throttle valve, worn needle jet, loose jets. |
| (4) Air cleaner being choked up. | |
| (5) An air cleaner having been removed. | |

Removing the silencer or running with a straight through pipe requires a richer setting.

Having verified the correctness of fuel feed and that there are no air leaks, check over ignition, valve operation and timing. Now at throttle position shown on page 7, fig. 5, test to see if mixtures are rich or weak. This is done by partially closing the air valve, and if engine runs better weakness is indicated, but if engine runs worse richness is indicated.

To remedy, proceed as follows :-

- | | | |
|-------------|--|---|
| Position 1. | To cure richness,
Fit smaller main jet. | To cure weakness,
Fit larger main jet. |
| Position 2. | Screw out pilot air adjusting screw. | Screw pilot air adjusting screw in. |
| Position 3. | Fit a throttle with larger cutaway (page 6). | Fit a throttle with smaller cutaway (page 6). |
| Position 4. | Lower needle one or two grooves (page 6). | Raise needle one or two grooves (page 6). |

NOTE. It is not correct to cure a rich mixture at half throttle by fitting a smaller main jet because the main jet may be correct for power at full throttle: the proper thing to do is to lower the needle.