

TRIUMPH

MOTOR CYCLES



INSTRUCTIONS
for the
S.U. CARBURETTER
TYPE MC 2

Specification No. 590

TRIUMPH ENGINEERING CO., LTD.

Meriden Works, Allesley
COVENTRY, ENGLAND
Telephone - - - Meriden 331
Telegrams - "Trusty, Coventry"

Nov. 1951

THE S.U. CARBURETTER

STARTING THE ENGINE.

1. Turn on the petrol tap.
2. On the left hand side of the carburetter will be found the jet lever. To increase the mixture strength for starting, the lever should be raised. No pre-determined position can be given as the characteristics of every engine fitted with this carburetter are not the same for starting. The lever position therefore is a matter of experiment until the rider is fully conversant with the setting.
3. Open the throttle slightly (about $\frac{1}{8}$ th turn) and turn the engine over with the kickstarter until compression is felt. The kickstarter crank should then be moved down to almost the horizontal position by freeing the clutch.
4. Depress the kickstarter smartly, when the engine should fire immediately; if not, re-position the jet lever and try again.
5. When the engine starts depress the jet lever into the closed position. In extreme cold weather it may be necessary partly to close the jet lever until the engine warms up.

Air Leak at Flange Joints. At all times ensure good jointing at the carburetter and flange joints, as an air leak at these joints will cause faulty carburation and bad starting, especially from cold.

WARNING. IF THE SUCTION CHAMBER OIL CAP IS LOST IT MUST BE REPLACED WITH THE STANDARD GREY PLASTIC CAP WITHOUT A HOLE.

THERE IS A CAP USED ON SOME CAR TYPE S.U. CARBURETTERS MADE OF BRASS OR BLACK PLASTIC WITH A HOLE DRILLED THROUGH IT. IF THIS TYPE OF CAP IS EMPLOYED, PETROL CONSUMPTION WILL BE VERY HEAVY UNLESS THE HOLE IS STOPPED UP.

ADJUSTMENT AND TUNING.

The S.U. carburetter is of the automatically expanding choke type in which the cross-sectional area of the air passage, and the effective orifice of the jet, is variable.

The choice of the needle, which governs the effective orifice of the jet, is only settled for a particular engine after considerable testing, both on the engine test bed and later on Road Test, and it is not, therefore, a common requirement that the needle type should be changed from the maker's original specification.

If any doubt arises as to the correctness of the type fitted, this can be checked by first removing the suction chamber and then slackening the side needle screw, when the needle can be pulled out and its marking by letters or numbers, checked. These identifying letters or numbers may be rolled around the shank or stamped on the flat end of the shank.

When detaching the suction chamber and piston unit from the main instrument (necessary when checking or changing the needle) it will be necessary, owing to lack of headroom, to lift the two units, that is the chamber and the inner piston, together as one, away from the carburetter body, and this will call for a certain amount of care and manual dexterity, as after the two side screws have been removed the suction chamber can only be lifted a limited amount; then one hand is required to raise the suction piston upwards inside the chamber against the mild load of the inner compression spring, whilst the second hand steadies the suction chamber; after which the complete unit can be moved sideways clear of the main instrument—great care must be taken, however, to see that the jet needle is not bent in the process. When re-fitting the suction chamber and piston the procedure is, of course, reversed, and the piston should be held as high up as possible inside the suction chamber whilst the whole unit is carefully guided into the position bore and jet in the main body.

It should be noted that where some alteration to mixture strength is required, it is the needle alone that is changed; the jet size remaining constant throughout a given range of carburetters.

When re-inserting the needle, the normal setting is with the shoulder (or junction between the straight part of the tapered working section of the needle, and its shank) just flush with the bottom of the piston rod into which it is inserted. This normal setting should only be changed by inserting the needle, say, a further $\frac{1}{32}$ " further in, if the position of the jet adjusting nut for normal running needs to be lower than three full turns downwards from its topmost possible position.

After checking, if this is considered necessary, the type of needle fitted, tuning of the carburetter is necessarily confined to correct idling adjustment. This operation should only be attempted after the engine has attained normal running temperature, and is carried out by means of the throttle stop screw (2), which governs the amount of throttle opening for idling, and the jet stop nut (18), which gives an enriching effect when screwed downwards, and a weakening effect when screwed upwards.

A correct idling mixture gives an even beat with a colourless exhaust—too rich a mixture gives a trace of black in the exhaust with a rythmical or regular misfire—too weak a mixture gives a splashy irregular type of misfire with a marked tendency to stop when only partially warm.

A second check on the correctness of the mixture strength may be made by unscrewing the hexagon headed 2 B.A. plug screw (29), immediately under the air intake (set in an angular position); and then with the engine idling a thin wire nail or similar type of metal rod is carefully pushed upwards until it lifts the suction piston, then any amount of manual lift over $\frac{1}{32}$ " should cause the engine to stop from weakness of mixture, and therefore, this setting can be taken as correct; if, on the other hand, a lift of approximately $\frac{1}{16}$ " causes the engine to

THE S.U. MC2

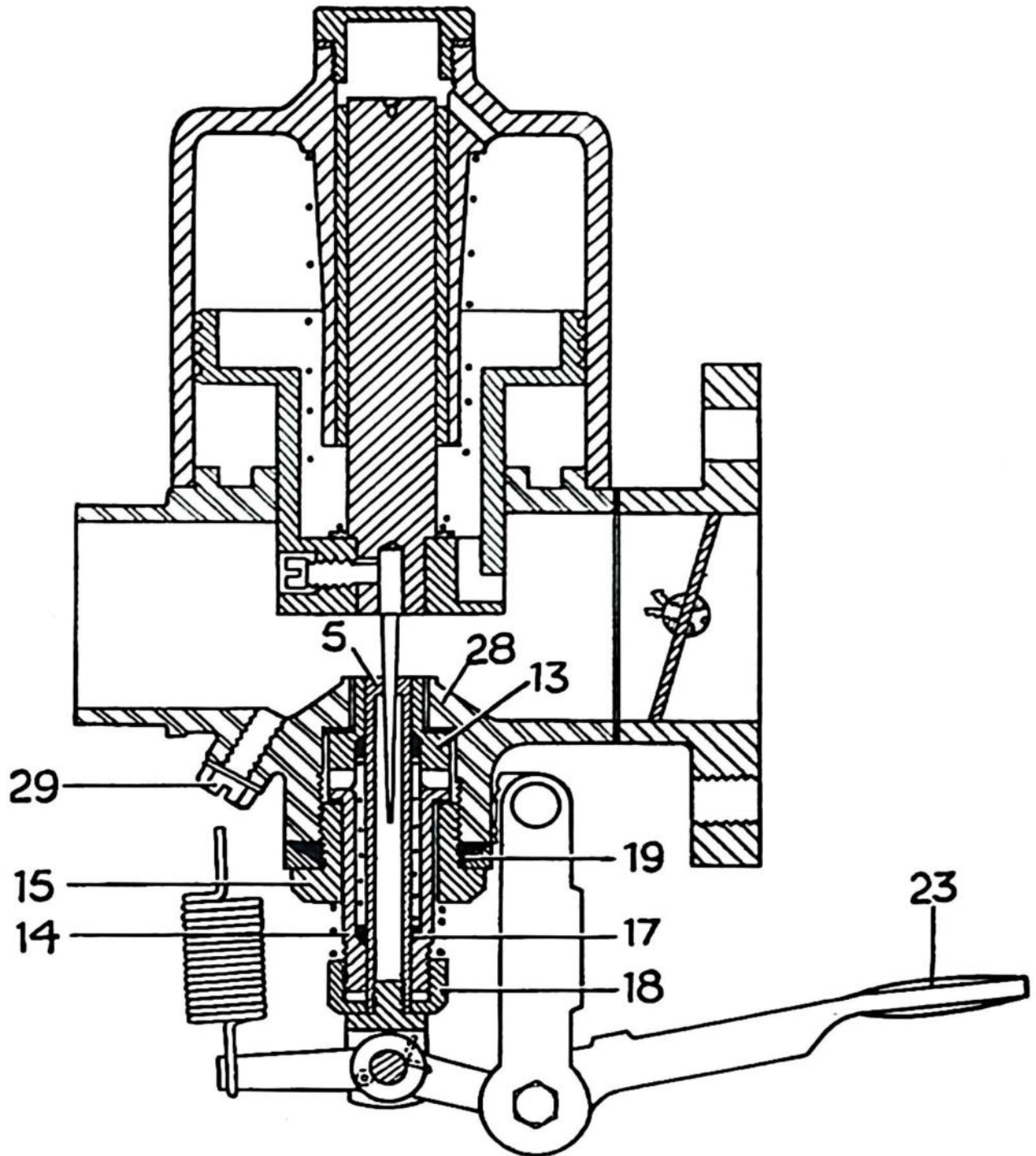

CARBURETTER

RETTER

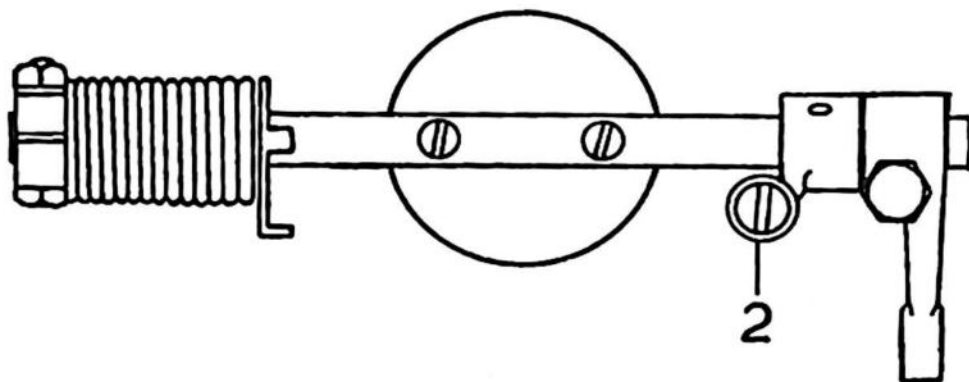
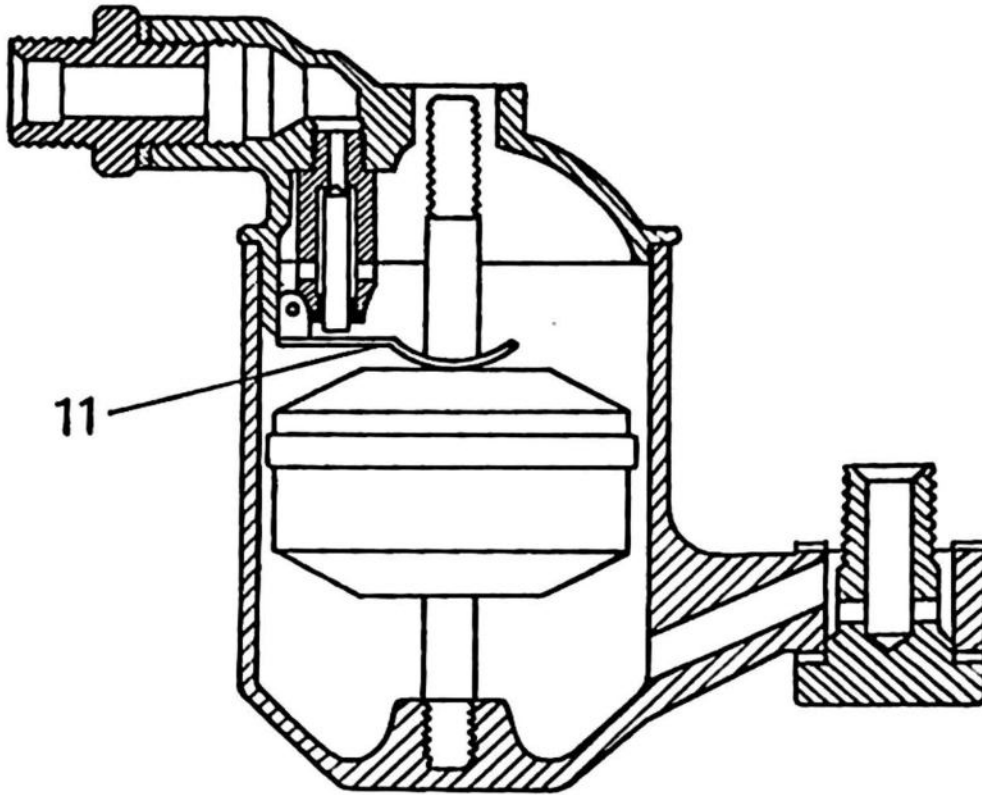

gain speed then the mixture strength is too rich and should be suitably weakened off.

DEFECTS IN OPERATION.

In the case of unsatisfactory engine performance, before making any alterations to the carburetter setting, a general check should be made on the ignition system, valves and valve guides in the engine, also the gas tightness of both induction pipe and carburetter flange joints.

If, however, the engine and ignition are found to be faultless, the following points should be checked on the carburetter.

I. Sticking of Piston.

The symptoms here are either stalling and a refusal of the engine to run slowly or, alternatively, lack of power accompanied by excessive fuel consumption. This defect is easily detectable. The piston should rest, when the engine is not running, upon the bridge (28). When raised by means of a rod inserted through the 2 B.A. hole under the air intake, as previously described, to its highest position against the appreciable resistance of the piston, and then released, it should drop freely, and strike the bridge sharply and distinctly. If it becomes prematurely arrested in its downward movement, or if it appears unduly reluctant to break away from its position of rest on the bridge when an attempt is made to raise it from this position, the jet should be lowered by means of the enrichment mechanism, and the test repeated.

If the previous symptoms persist it can be assumed either that the enlarged diameter of the piston is making contact with the bore of the suction chamber, or that the piston rod is not sliding freely within its bush.

If, on the other hand, sticking has been eliminated by the act of dropping the jet, the indication is that contact and friction are taking place between the jet and the needle.

Rectification should be conducted as follows, according to the diagnosis.

DIRT OR CONTACT BETWEEN THE PISTON AND SUCTION CHAMBER, OR STICKING OF THE PISTON ROD IN ITS BUSH.

Remove the suction chamber, withdraw the piston and thoroughly clean both parts with petrol and a clean cloth. Apply a few drops of light oil to the piston rod, preferably diluted with paraffin if any signs of rust or corrosion are noticed on the rod. Replace the piston in the suction chamber and test for rotational and sliding freedom. Any direct local contact between these two parts, attributable to some indentation of the suction chamber, may be rectified by carefully removing any high spots which may show up on the suction chamber bore by means of a hand scraper. On no account should any attempt be made to enlarge generally the bore of the suction chamber, or to reduce the diameter of the enlarged part of the piston, as the maintenance of a limited clearance between these parts is absolutely essential.

LUBRICATION.

Each month remove the plastic octagonal oil cap from the top of the suction chamber and feed a few drops of thin machine oil into the orifice. When the oil cap has been replaced, ensure it is well tightened. An air leak occurring at this point would upset the automatic operation of the piston in the suction chamber and cause faulty carburation.

ECCENTRICITY OF JET AND NEEDLE.

Re-centring of the jet in relation to the needle will be necessary should the jet have become laterally displaced in service due to inadequate tightening of the locking screw (15), or any other cause. This operation will, of course, also be necessary if the jet and its associated parts have been removed for any reason. It may also be necessary after the removal and replacement of a needle. The procedure for the re-centring of the jet is as follows.

The jet stop nut (18), should first be screwed upwards to its fullest extent, the jet head then being raised to contact it

so that the jet assumes its highest possible position. The locking screw (15) should now be loosened just sufficiently to release the jet and jet bush assembly (5), (13), (14), etc. and permit this to be moved laterally.

A moderate side loading applied to the lower protruding part of the lower jet bush (14), will indicate whether or not the assembly has been sufficiently freed. The piston should now be raised, and, maintaining the jet in its highest position, the piston should be allowed to drop. This will cause the needle to be driven fully into the jet mouth, and thus bring about the required centralisation. The locking screw should now be tightened and the jet returned to its former position. Should any indication of contact between the needle and the jet persist, which may sometimes occur due to further displacement of the assembly on finally tightening the locking screw, this must again be slacked off and the operation repeated.

2. Flooding from Float-chamber or mouth of Jet.

Flooding may occur due to a punctured and petrol-laden float, or to dirt between the float chamber needle valve and its seating. To remedy either defect, the float chamber lid should be removed, and the necessary cleaning, float replacement or repair effected. The needle and seating unit number is T2; to identify, two ring grooves are machined around the seating.

Flooding also may occur if the original manufacturer's setting of the hinged fork lever (11), in the top of the float chamber has been disturbed, possibly causing the petrol level to be higher than normal, this higher level giving a slow petrol bleed over the jet bridge. The setting figure for this fork is that with the fork pressing the needle home in its seating then a $\frac{3}{8}$ " dia. test bar should just slide easily between the curve of the fork and the circular facing of the float lid casting.

3. Leakage from bottom of Jet.

If persistent slow leakage is observed in the neighbourhood of the jet head, it is probable that the jet gland washer (7), and its lower counterpart, together with the locking screw washer (19), require replacement. The jet lever (23), should first be detached from the jet head, the locking screw (15), removed, and the entire jet and jet bush assembly withdrawn. On reassembly, great care should be taken to replace all parts in their correct situations, as shown in the diagram. Re-centring of the jet, as previously described, will, of course, be necessary after this operation.

AIR FILTER.

THE AIR FILTER SHOULD NOT BE DISCONNECTED IN AN ATTEMPT TO INCREASE THE MAXIMUM SPEED OF THE MACHINE, THE CARBURETTER AND AIR FILTER BEING DESIGNED TO GIVE MAXIMUM EFFICIENCY, AND IN FACT THE REMOVAL OF THE FILTER WILL IMPAIR THE GENERAL PERFORMANCE OF THE ENGINE.

AS THE CARBURETTER IS EXPOSED TO ROAD DUST AND OTHER FOREIGN MATTER IF THE AIR FILTER IS NOT CONNECTED, THERE IS A POSSIBILITY THAT THE FREEDOM OF THE PISTON IN THE SUCTION CHAMBER WILL BE INTERFERED WITH. THIS IS NOT A DESIRABLE CONDITION AS THE PERFORMANCE OF THE MACHINE AND FUEL CONSUMPTION WILL BE AFFECTED.