

Mark 2 Range of Amal Concentric Carburetors

Developed from the well-known Mark 1 Amal Concentric, the Mark 2 range has been designed to meet the exacting performance requirements of modern motorcycles. It has also been given the functional styling currently popular among riders world-wide.

The Mark 2 range is available in three body sizes, giving an option of ten bore diameters from 22 to 40 mm. A number of extra features are incorporated:

- ★ The smoothly contoured tract shape of the air intake tube tapers concentrically straight into the carburetor bore, giving improved air flow and greater engine power output.
- ★ The cold-starting mixture-enrichment device is operated by a lever mounted directly on the carburetor body. An alternative arrangement with cable control from the handlebar, or elsewhere on the machine is also available (as illustrated on this page).
- ★ The carburetor is designed for flexible mounting, giving excellent insulation from vibration on modern high-speed high-performance engines.
- ★ The screw-off top to the mixing chamber allows quick and easy servicing and tuning.
- ★ Two float-chamber vent tubes mounted high up on the carburetor body prevent fuel spillage under extreme conditions.
- ★ To achieve a truly light-weight carburetor, the body and other component parts are precision diecast in aluminium alloy.

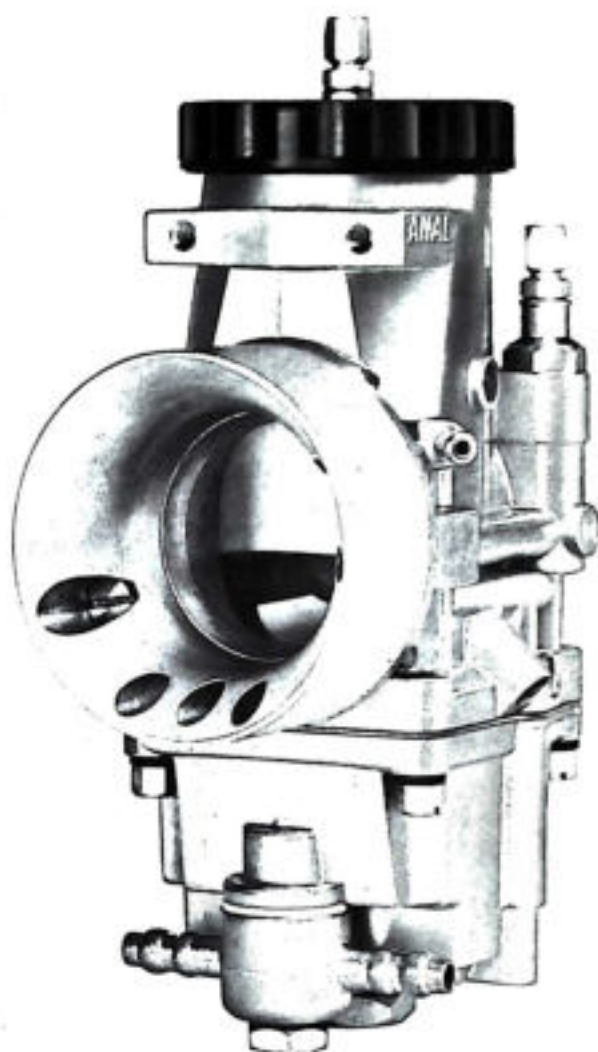

Obtainable from

dealer

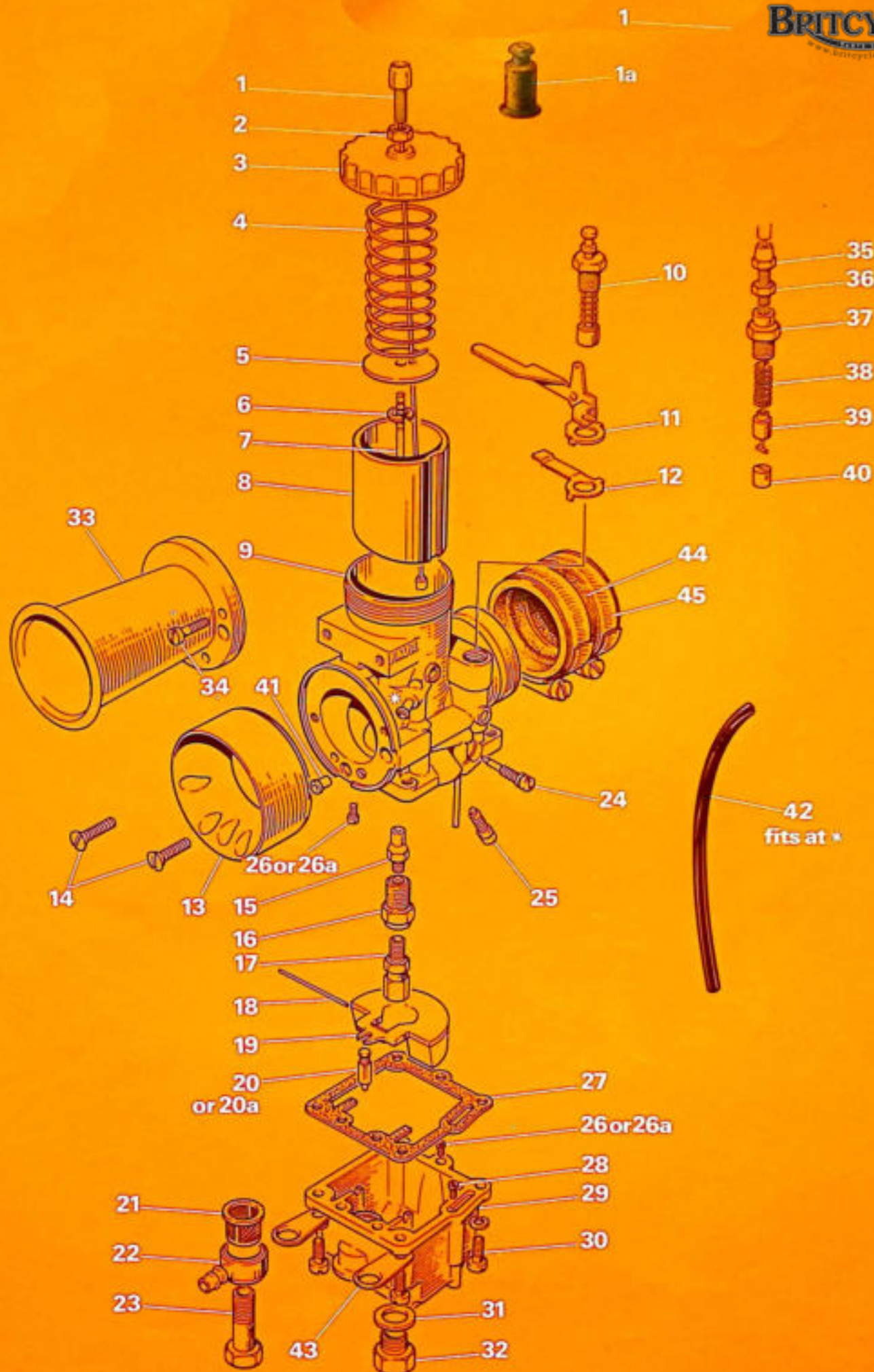

Service Parts for Mark 2 Amal Concentric Carburetors



Key to Illustration	Component	Carburetor Series 2600	Carburetor Series 2900	Carburetor Series 2000
1	Cable adjuster	4/035	4/035	4/035
1a	Throttle cable adjuster sheath	316/083	316/083	316/083
2	Cable-adjuster locknut	5/077	5/077	5/077
3	Mixing-chamber top (standard)	2622/064	2928/064	2036/064
Not shown	Mixing-chamber top for ferrule	2622/120	2928/120	2036/120
4	Throttle-slide spring	2622/061	2928/061	2928/061
5	Needle retaining disc	2622/071	2928/071	2928/071
6	Needle clip	2622/067	2622/067	2622/067
7	Throttle needle (paired with 2-cycle needle jet below)	2622/063	2928/063	2036/063
7	Throttle needle (paired with 4-cycle needle jet below)	2622/124	2622/124	2622/124
7	Throttle needle (for alcohol)	2622/125	2928/125	2036/077
8	Throttle slide (specify cutaway)	2622/060	2928/060	2036/060
9	Carburetor body assembly	*	*	*
10	Cold start plunger assembly (lever operated)	2622/079	2622/079	2622/079
11	Cold start lever and bracket assembly	2622/075	2622/075	2622/075
12	Cold start click spring	2622/087	2622/087	2622/087
13	Air intake adaptor	2622/062	2928/062	2036/062
14	Air intake adaptor securing screws	2622/073	2622/073	2622/073
15	Needle jet (preferred for 2-cycle engines)	622/079	2928/079	2928/079
15	Needle jet (preferred for 4-cycle engines)	622/122	2928/122	622/122
15	Needle jet (for alcohol)	622/100	2928/100	2928/100
16	Jet holder (long)	622/128	622/128	622/128
16	Jet holder (short)	1034/080	1034/080	—
17	Main jet (specify size)	376/100	376/100	376/100
18	Float spindle	2622/069	2622/069	2622/069
19	Float (shallow)	622/069	622/069	622/069
19	Float (deep)	622/196	622/196	622/196
20	Float needle	622/149	622/149	622/149
20a	Float needle (for alcohol only)	622/279	622/279	622/279
21	Filter	376/093	376/093	376/093
21	Filter (for alcohol)	376/093B	376/093B	376/093B
22	Banjo, single, push-on ($\frac{1}{8}$ in. inside diameter tubing)	376/097	376/097	376/097
22	Banjo, double, 90°, push-on ($\frac{1}{8}$ in. tubing)	376/135	376/135	376/135
22	Banjo, double, 150°, push-on ($\frac{1}{8}$ in. tubing)	376/139	376/139	376/139
22	Banjo, double, 55°, push-on ($\frac{1}{8}$ in. tubing)	376/410	376/410	376/410
22	Banjo, double, 180°, push-on ($\frac{1}{8}$ in. tubing)	376/419	376/419	376/419
Not shown	Banjo, washer (for alcohol only)	14/175	14/175	14/175
Not shown	Banjo bolt washer (for metal banjo only)	13/163	13/163	13/163
23	Banjo bolt	622/078	622/078	622/078
23	Banjo bolt (for alcohol)	2622/155	2622/155	2622/155
24	Pilot-air adjusting-screw assembly	2622/128	2622/128	2622/128
25	Throttle-stop adjusting-screw assembly	2622/129	2622/129	1222/129
26	Pilot jet	124/026	124/026	124/026
26a	Blank pilot plug	2622/142	2622/142	2622/142
27	Float bowl washer	2622/070	2622/070	2622/070
28	Cold start jet	124/026	124/026	124/026
29	Float bowl—0-10 in. seating (2-5 mm)	2622/055	2622/055	2622/055
29	Float bowl—0-062 in. seating (1-6 mm) rec. for pump feed	2622/056	2622/056	2622/056
29	Float bowl—0-125 in. seating (3-2 mm) standard	2622/057	2622/057	2622/057
29	Float bowl—0-156 in. seating (4-0 mm) rec. for alcohol	2622/058	2622/058	2622/058
30	Float-bowl securing screws	622/086	622/086	622/086
31	Float-bowl drain-plug washer	2622/066	2622/066	2622/066
32	Float-bowl drain-plug	2622/065	2622/065	2622/065
33	Velocity stack	2622/126	2928/126	2036/126
34	Velocity stack securing screws	2036/073	2036/073	2036/073
35	Adjuster	4/035	4/035	4/035
36	Adjuster locknut	5/077	5/077	5/077
37	Screw	2622/091	2622/091	2622/091
38	Spring	2622/084	2622/084	2622/084
39	Plunger cap	2622/092	2622/092	2622/092
40	Plunger assembly	2622/094	2622/094	2622/094
41	Primary air jet	2622/135	2622/135	2622/135
42	Air vent pipe	2622/145	2622/145	2622/145
43	Air vent pipe clip	2622/134	2622/134	2622/134
44	Rubber stub adaptor (standard)	2622/123	2928/123	2036/123
44	Rubber stub adaptor (for alcohol)	—	2928/119	2036/119
45	Adaptor clip	2622/146	2928/146	2036/146

Alternative
cable-operated
cold start

*When ordering spares, please quote complete carburetor number.

Dimensions

		A	B	C*	D	E	F	G†	H	J
Series 2600	mm	60	75	52	62	40	66	27	53.5	49.5
Series 2900	mm	62	79.5	58	66.5	40	72.5	32	56	49.5
Series 2000	mm	72	82	62	69	40	75.5	38	58.5	49.5

		K	L	M	N	O	P	Q*	R*	S‡
Series 2600	mm	33	19.5	22.5	15	10	4	35	33	22, 24 or 26
Series 2900	mm	38	15	22.5	15	8	4	40	38	28, 30, 32 or 34
Series 2000	mm	48	15	22.5	15	8	4	43 or 46	41 or 44	36, 38 or 40

*Diameter

†Two holes, tapped M6-6H (Series 2600: M5-6H)

‡Bore diameter

